



**ADEL CITY COUNCIL AGENDA**  
*Tuesday, July 9, 2024 at 6:00 PM*  
**Adel City Hall, 301 S 10th Street Adel, IA 50003**

**FULL AGENDA PACKET ACCESS** *To access the full Agenda Packet please visit [Agendas & Minutes \(adeliowa.org\)](https://www.adeliowa.org) and click on the link to the Agenda Packet for this meeting.*

**MAYORAL RECOGNITION**

- 1.a. Police Chief's Secretary Jill Anderson - 10 Years of Service

**COMMENTS FROM THE PUBLIC**

- 2.a. Grace Pettit - Discuss Requested Changes to Chapter 55, Animal Protection and Control, Specifically Vicious Dogs

**CONSENT AGENDA**

- 3.a. Consider Approval of City Minutes Dated June 11, 2024
- 3.b. Consider Approval of June Bills and June 30, 2024 Treasurer's Report
- 3.c. Consider Approval Granting Permission to ADM Community School District to Discharge Fireworks at Home Football Games During the 2024 Season
- 3.d. Consider Approval of Class B Retail Alcohol License for Family Dollar Stores
- 3.e. Consider Approval to Ratify 2024/2025 Cigarette Permit for CIV Plus Adel
- 3.f. Consider Approval of Resolution No. 24-39, Street Closure for Locust St Block Party on July 27, 2024
- 3.g. Consider Approval of Sound Permit - Locust Street Block Party - July 27, 2024
- 3.h. Consider Approval of Resolution No. 24-40, Street Closure for Shelby Dr Block Party on August 17, 2024
- 3.i. Consider Approval of Change Order No. 1 - Adel Evans Park Trail Connections Project
- 3.j. Consider Approval of Pay Application No. 2 - Adel Evans Park Trail Connections Project
- 3.k. Consider Approval of Change Order No. 2 - Adel N. 15th Street Bridge Replacement Over Butler Creek Project
- 3.l. Consider Approval of Pay Application No. 3 - Adel N. 15th Street Bridge Replacement Over Butler Creek Project

**DEPARTMENT HEAD REPORT**

- 4.a. Second Council Meeting in July for "EOS Vision Building Day" Session - Monday, July 22 at 3:00 p.m.

**OLD BUSINESS**

**NEW BUSINESS**

- 6.a. Consider Approval of Mayor Board and Commission Appointments: Historic Preservation

Commission - One Opening

- 6.b. Consider Approval of Resolution No. 24-41, Approving a 28E Agreement for Animal Shelter Services Between the City of Adel and AHeinz57 Pet Rescue and Transport, Inc.
- 6.c. Consider Approval of Revised Live Trap Policy - Policy #5.05.01
- 6.d. Consider Approval of Ordinance No. 409, Amending Chapter 55, Animal Protection and Control For the Purpose of Removing References to Animal Licenses and To Increase the Administrative Impound Fee - First Reading
- 6.e. Consider Approval of Resolution No. 24-42, Setting the FY2024-2025 Fees for Services
- 6.f. Consider Approval of Resolution No. 24-43, Approving City of Adel Employee Handbook for Fiscal Year 2024-2025
- 6.g. Consider Approval of Resolution No. 24-44, Setting A Date for a Public Hearing on the Proposed Vacations of Right-of-Ways Along Bradfield Street Within Southbridge Plat 7 for 6:00 p.m. on Tuesday, August 13th, 2024

**OTHER BUSINESS**

**ADJOURNMENT**



# *Certificate of Appreciation*

*presented to*

**JILL ANDERSON**

*in recognition of her 10 years of service to*

*The Citizens of Adel and  
The Adel Police Department*

---

*James F. Peters, Mayor*

**From:** [Grace Pettit](#)  
**To:** [Carrie Erickson](#); [Steve Nichols](#); [Wade Book](#)  
**Subject:** Draft Proposed Changes to Chapter 55 Animal Protection and Control  
**Date:** Monday, July 1, 2024 10:30:08 PM  
**Attachments:** [Adel City Ordinance Chapter 55 proposed changes.docx](#)

---

**CAUTION:** This email originated from outside the City of Adel's internal network. Do not click links, open attachments, or process requests unless you recognize the sender, know the content is safe, or verify that the request is authentic.

Greetings All,

Please find attached a draft copy of proposed changes to Adel City Ordinance Chapter 55 Animal Protection and Control. Changes have been highlighted with yellow. To come up with the suggested changes, I utilized similar ordinances in Des Moines (DM Chapter 18, Animals) and Windsor Heights (WH Chapter 56 Dangerous Dogs). Please note I included a cross-reference to a similar code in the noted suggested changes that follow.

Suggested changes include:

- Current definition of "vicious dog" changed to "potentially dangerous dog", with revisions. (DM Sec. 18-41 high risk dog; WH Sec. 56.01 potentially dangerous dog)
- Added definition "dangerous dog". (DM Sec. 18-196 dangerous animal; WH Sec. 56.01 dangerous dog)
- Added definition "habitual offender". (DM Sec. 18-41)
- Section 55.09 Vicious Dogs changed to Section 55.09 Dangerous and Potentially Dangerous Dogs.
- Changes within Section 55.09:
  1. Term "vicious dog" changed to "potentially dangerous dog" throughout.
  2. For potentially dangerous dog, in 3A and 3B added muzzle requirement for the times the dog is not securely confined or caged for transportation. (WH Sec. 56.01 within definitions of "proper enclosure" and "proper leashing")
  3. For potentially dangerous dog, in 3B Leashing, added "a person who has physical ability to restrain the dog". (WH Sec. 56.01 in definition of "proper leashing")
  4. For a potentially dangerous dog, in 3C At Large, removed the calendar year requirement when counting the number of times the dog is found at large, and added an exception to allow for potential adoption of the animal. (DM Sec. 18-57 and Sec. 18-66)
  5. For a potentially dangerous dog, added 3D Potentially dangerous dogs evaluated for adoption. (DM Sec. 18-66)
  6. For a potentially dangerous dog, added 3E Warning sign requirement.
  7. For a potentially dangerous dog, in 3F Unlicensed, even though there is no longer a dog licensing requirement in the city, I see that this statement is still included that requires such dogs to be destroyed, so I've added the exception to allow for potential adoption.
  8. Added new 4A through 4D for dangerous dogs. Bottom line is that such dogs have no second chance, unless overturned on appeal, and must be destroyed. (WH Sec. 56.03 and DM Sec. 18-202)
  9. Note: With the addition of new 4A through 4D for dangerous dogs, please see the failure to comply statement that makes it a misdemeanor offense (4D). I don't find a statement of that sort relating to a potentially dangerous dog, or the other portions of this Chapter 55. Perhaps it is covered elsewhere? If so, then 4D won't be needed.

- Section 55.12 Redemption of Impounded Animals, added a fee for a habitual offender. I took a guess at what might be appropriate on the dollar amount for the fee. (DM Sec. 18-64(d))
- Various other clarifying or typographical error revisions.

For your reference, following are links to the portions of the Code of Ordinance for each Des Moines and Windsor Heights from which I gleaned material or ideas for the suggested changes to the Adel Code of Ordinance:

- Des Moines, Chapter 18 Animals: [https://library.municode.com/ia/des\\_moines/codes/code\\_of\\_ordinances?nodeId=MUCO\\_CH18AN](https://library.municode.com/ia/des_moines/codes/code_of_ordinances?nodeId=MUCO_CH18AN)
- Windsor Heights, Chapter 56 Dangerous Dogs: [https://codelibrary.amlegal.com/codes/windsorheightsia/latest/windsorheights\\_ia/0-0-0-10767](https://codelibrary.amlegal.com/codes/windsorheightsia/latest/windsorheights_ia/0-0-0-10767)

Please let me know if you require any additional information or materials from me prior to the meeting. Thank you for your time!

Kind regards,

Grace Pettit  
(515) 250-5694

**CAUTION:** Were you expecting this file? If not please contact the sender of the file to verify its authenticity.

**CHAPTER 55**  
**ANIMAL PROTECTION AND CONTROL**

Formatted: Font: 12 pt

<a href="#">55.01</a> Definitions	<a href="#">55.10</a> Owner's Duty
<a href="#">55.02</a> Animal Neglect	<a href="#">55.11</a> Impounding Animals At Large
<a href="#">55.03</a> Livestock Neglect	<a href="#">55.12</a> Redemption of Impounded Animals
<a href="#">55.04</a> Abandonment of Cats and Dogs	<a href="#">55.13</a> Disposition of Unclaimed Animals
<a href="#">55.05</a> Livestock	<a href="#">55.14</a> Right to Kill Unlicensed or Licensed Dog or Cat
<a href="#">55.06</a> At Large Prohibited	<a href="#">55.15</a> Pet Awards Prohibited
<a href="#">55.07</a> Damage or Interference	<a href="#">55.16</a> Immunization; Tampering With A Rabies Vaccination Tag
<a href="#">55.08</a> Annoyance or Disturbance	<a href="#">55.17</a> Tampering With An Electronic Handling Device
<a href="#">55.09</a> <del>Vicious</del> <b>Dangerous and Potentially Dangerous Dogs</b>	

Formatted: Strikethrough, Highlight

Formatted: Highlight

Formatted: Font: 12 pt

**55.01 DEFINITIONS.**

The following terms are defined for use in this chapter.

1. "Advertise" means to present a commercial message in any medium, including (but not limited to) print, radio, television, sign, display, label, tag, or articulation.

*(Code of Iowa, Sec. 717E.1)*

2. "Animal" means a nonhuman vertebrate.

*(Code of Iowa, Sec. 717B.1)*

3. "Animal shelter" means a facility which is used to house or contain dogs or cats, or both, and which is owned, operated, or maintained by an incorporated humane society, animal welfare society, society for the prevention of cruelty to animals, or other nonprofit organization devoted to the welfare, protection, and humane treatment of such animals.

*(Code of Iowa, Sec. 162.2)*

4. "At large" means off the premises of the owner and not under the control of a competent person, restrained within a motor vehicle, or housed in a veterinary hospital or kennel.

5. "Business" means any enterprise relating to any of the following:

*(Code of Iowa, Sec. 717E.1)*

- A. The sale or offer for sale of goods or services.
- B. A recruitment for employment or membership in an organization.
- C. A solicitation to make an investment.

D. An amusement or entertainment activity.

6. “Commercial establishment” means an animal shelter, boarding kennel, commercial breeder, commercial kennel, dealer, pet shop, pound, public auction, or research facility.

*(Code of Iowa, Sec. 717.B1)*

7. “Dangerous dog” means any dog that has bitten or clawed a person while running at large and the attack was unprovoked, or that has exhibited vicious propensities in present or past conduct, including such that the dog:

A. Has attacked or bitten a person on two separate occasions within the lifetime of the attacking dog; or—

B. Did attack or bite once causing injuries above the shoulders of a person; or

C. Could not be controlled or restrained by the owner at the time of the attack to prevent the occurrence; or

D. Has attacked any domestic animal or fowl on three or more separate occasions within the lifetime of the attacking dog; or

E. Has killed any domestic animal while off of the property where the attacking dog is kept by its owner; or

F. Has bitten another animal or person that causes a fracture, muscle tear, disfiguring lacerations or injury requiring corrective or cosmetic surgery; or

G. Was required to be removed from another city or county because of behavior that would also meet the definition of “dangerous dog” as set out in this section.

78. “Fair” means any of the following:

*(Code of Iowa, Sec. 717E.1)*

A. The annual fair and exposition held by the Iowa State Fair Board pursuant to Chapter 173 of the *Code of Iowa* or any fair event conducted by a fair under the provisions of Chapter 174 of the *Code of Iowa*.

B. An exhibition of agricultural or manufactured products.

C. An event for operation of amusement rides or devices or concession booths.

89. “Game” means a “game of chance” or “game of skill” as defined in Section 99B.1 of the *Code of Iowa*.

*(Code of Iowa, Sec. 717E.1)*

10. “Habitual offender” means any person who has been convicted of any violation relating to dogs under this chapter three or more times in a five-year period, except that multiple convictions or violations occurring as a result of a single incident will count as one conviction for purposes of this definition.

*(Code of Iowa, Sec. 717E.1)*

Formatted: Highlight

Formatted: Font: (Default) Times New Roman, 12 pt, Highlight, Ligatures: None

Formatted: Font: (Default) Times New Roman, 12 pt, Highlight, Ligatures: None

Formatted

Formatted: Font: (Default) Times New Roman, 12 pt, Highlight, Ligatures: None

Formatted: Highlight

Formatted: Highlight

Formatted: Font: (Default) Times New Roman, 12 pt, Highlight, Ligatures: None

Formatted: Highlight

Formatted: Highlight

Formatted: Highlight

911. "Injury" means an animal's disfigurement; the impairment of an animal's health; or an impairment to the functioning of an animal's limb or organ, or the loss of an animal's limb or organ.

(Code of Iowa, Sec. 717.B1)

129. "Livestock" means an animal belonging to the bovine, caprine, equine, ovine or porcine species, ostriches, rheas and emus; farm deer (as defined in Section 170.1 of the Code of Iowa); or poultry.

(Code of Iowa, Sec. 717.1)

134. "Owner" means any person owning, keeping, sheltering, or harboring an animal.

142. "Pet" means a living dog, cat, or an animal normally maintained in a small tank or cage in or near a residence, including but not limited to a rabbit, gerbil, hamster, mouse, parrot, canary, mynah, finch, tropical fish, goldfish, snake, turtle, gecko, or iguana.

(Code of Iowa, Sec. 717E.1)

15. "Vicious dog" "Potentially dangerous dog" means a dog that may reasonably be assumed to pose a threat to public safety as demonstrated by any of the following behaviors:

- A. Without provocation, has attacked or bitten a person or domestic animal one or more times; or
- B. Without provocation, chases or approaches a person, a domestic animal or a wheeled conveyance upon the streets, sidewalks, or any public or private property, in an apparent attitude of attack; or has a known propensity, tendency, or disposition to attack, causing injury or otherwise threatening the safety of a person or domestic animal; or
- C. Without provocation, acts in a highly aggressive manner within a fenced yard or enclosure and appears, to a reasonable adult, able to jump over or escape; or
- D. Snaps, bites, or manifests a disposition to snap or bite; or
- E. Has been trained for dogfighting, animal fighting or animal baiting or is owned or kept for such purposes; or
- F. Has been trained to attack persons, upon command or spontaneously in response to human activities, except dogs owned by and under the control of the police department, a law enforcement agency of the state or United States or a branch of the armed forces of the United States.

163. "Pound" means a facility for the prevention of cruelty to animals operated by the State, a municipal corporation, or other political subdivision of the State for the purpose of impounding or harboring seized stray, homeless, abandoned, or unwanted dogs, cats, or other animals; or a facility operated for such a purpose under a contract with any municipal corporation or incorporated society.

(Code of Iowa, Sec. 162.2)

174. "Research facility" means any school or college of medicine, veterinary medicine, pharmacy, dentistry, or osteopathic medicine, or hospital, diagnostic or research laboratories, or other educational or scientific establishment situated in the State concerned with the

Formatted: Highlight

Formatted: Highlight

Formatted: Highlight

Formatted: Highlight

Formatted: Highlight

Formatted: Highlight

Formatted: Highlight

Formatted: Highlight

Formatted: Highlight

Formatted: Highlight

Formatted: Highlight

Formatted: Highlight

Formatted: List Paragraph, Numbered + Level: 1 + Numbering Style: A, B, C, ... + Start at: 1 + Alignment: Left + Aligned at: 0.25" + Indent at: 0.53"

Formatted: Highlight

Formatted: Highlight

Formatted: Highlight

Formatted: Font: (Default) Times New Roman, 12 pt, Ligatures: None

Formatted: Highlight

Formatted: Highlight

investigation of, or instruction concerning the structure or function of living organisms, the cause, prevention, control, or cure of diseases or abnormal conditions of human beings or animals.

*(Code of Iowa, Sec. 162.2)*

**185.** “Veterinarian” means a veterinarian licensed pursuant to Chapter 169 of the Code of Iowa who practices veterinary medicine in the State.

*(Code of Iowa, Sec. 717.B1)*

16. “Vicious dog” means:

~~A. Any dog which has attacked or bitten a human being or domestic animal one or more times, without provocation.~~

~~B. Any dog that has been trained for dogfighting, animal fighting or animal baiting or is owned or kept for such purposes.~~

~~C. Any dog trained to attack human beings, upon command or spontaneously in response to human activities except dogs owned by and under the control of the Police Department, a law enforcement agency of the State or United States or a branch of the armed forces of the United States.~~

*(Section 55.01 - Ord. 358 - Aug. 20 Supp.)*

#### **55.02 ANIMAL NEGLECT.**

1. It is unlawful for a person who owns or has custody of an animal and confines that animal to fail to provide the animal with any of the following conditions for the animal’s welfare:

*(Code of Iowa, Sec. 717B.3)*

A. Access to food in an amount and quality reasonably sufficient to satisfy the animal’s basic nutrition level to the extent that the animal’s health or life is endangered.

B. Access to a supply of potable water in an amount reasonably sufficient to satisfy the animal’s basic hydration level to the extent that the animal’s health or life is endangered. Access to snow or ice does not satisfy this requirement.

C. Sanitary conditions free from excessive animal waste or the overcrowding of animals to the extent that the animal’s health or life is endangered.

D. Ventilated shelter reasonably sufficient to provide adequate protection from the elements and weather conditions suitable for the age, species, and physical condition of the animal so as to maintain the animal in a state of good health to the extent that the animal’s health or life is endangered. The shelter must protect the animal from wind, rain, snow, or sun and have adequate bedding to provide reasonable protection against cold and dampness. A shelter may include a residence, garage, barn, shed, or doghouse.

E. Grooming, to the extent it is reasonably necessary to prevent adverse health effects or suffering.

F. Veterinary care deemed necessary by a reasonably prudent person to relieve an animal’s distress from any of the following:

Formatted: Highlight

Formatted: Font: (Default) Times New Roman, 12 pt, Ligatures: None

Formatted: Normal, No bullets or numbering

(1) A condition caused by failing to provide for the animal's welfare as described in this section.

(2) An injury or illness suffered by the animal causing the animal to suffer prolonged pain and suffering.

2. This section does not apply to any of the following:

A. A person operating a commercial establishment under a valid authorization issued or renewed under Section 162.2A of the *Code of Iowa*, or a person acting under the direction or supervision of that person, if all of the following apply:

(1) The animal, as described in Subsection 1, was maintained as part of the commercial establishment's operation.

(2) In providing conditions for the welfare of the animal, as described in Subsection 1, the person complied with the standard of care requirements provided in Section 162.10A[1] of the *Code of Iowa*, including any applicable rules adopted by the Department of Agriculture and Land Stewardship applying to: (i) a State licensee or registrant operating pursuant to Section 162.10A[2a] or [2b] of the *Code of Iowa*; or (ii) a permittee operating pursuant to Section 162.10A[2c] of the *Code of Iowa*.

B. A research facility if the research facility has been issued or renewed a valid authorization by the Department of Agriculture and Land Stewardship pursuant to Chapter 162 of the *Code of Iowa*, and performs functions within the scope of accepted practices and disciplines associated with the research facility.

*(Section 55.02 - Ord. 358 - Aug. 20 Supp.)*

#### **55.03 LIVESTOCK NEGLECT.**

It is unlawful for a person who impounds or confines livestock in any place to fail to provide the livestock with care consistent with customary animal husbandry practices or to deprive the livestock of necessary sustenance or to injure or destroy livestock by any means that causes pain or suffering in a manner inconsistent with customary animal husbandry practices.

*(Code of Iowa, Sec. 717.2)*

#### **55.04 ABANDONMENT OF CATS AND DOGS.**

It is unlawful for a person who owns or has custody of a cat or dog to relinquish all rights in and duties to care for the cat or dog. This section does not apply to any of the following:

*(Code of Iowa, Sec. 717B.8)*

1. The delivery of a cat or dog to another person who will accept ownership and custody of the cat or dog.

2. The delivery of a cat or dog to an animal shelter or that has been issued or renewed a valid authorization by the Department of Agriculture and Land Stewardship under Chapter 162 of the *Code of Iowa*.

3. A person who relinquishes custody of a cat at a location in which the person does not hold a legal or equitable interest, if previously the person had taken custody of the cat at the same location and provided for the cat's sterilization by a veterinarian.

*(Section 55.04 - Ord. 358 - Aug. 20 Supp.)*

**55.05 LIVESTOCK.**

It is unlawful for a person to keep livestock within the City except by written consent of the Council or except in compliance with the City's zoning regulations.

**55.06 AT LARGE PROHIBITED.**

It is unlawful for any owner to allow an animal to run at large within the corporate limits of the City.

**55.07 DAMAGE OR INTERFERENCE.**

It is unlawful for the owner of an animal to allow or permit such animal to pass upon the premises of another thereby causing damage to, or interference with, the premises.

**55.08 ANNOYANCE OR DISTURBANCE.**

It is unlawful for the owner of a dog to allow or permit such dog to cause serious annoyance or disturbance to any person by frequent and habitual howling, yelping, barking, or otherwise, or by running after or chasing persons, bicycles, automobiles or other vehicles.

**55.09 VICIOUS DANGEROUS AND POTENTIALLY DANGEROUS DOGS.**

1. Determination. The determination as to whether a particular dog is a ~~vicious, dangerous dog~~ or ~~potentially dangerous dog~~ shall be made by the Chief of Police on the basis of reasonable evidence, which may include, but is not limited to, consideration of a verified report of an incident involving unprovoked aggressive behavior directed at a person or a domestic animal; any provocation or trespass on the part of the animal attacked; compliance, or lack of same, with all animal control ordinances on the part of any dog or person responsible for any dog; and the opinions of experts.

**2. Securing Dog Investigation.**

A. During the period of investigation, a peace officer shall have the authority to order the owner or keeper of any dog under investigation to secure that animal. This may include the directive that the dog be secured off the premises of the owner or keeper, at the owner's expense.

B. Failure to strictly comply with all conditions of the order to secure a dog during investigation shall be a municipal infraction punishable by a fine of \$500 for a first offense and \$750 for any subsequent offense. Each day that the violation occurs or is permitted to exist constitutes a separate offense.

C. If the peace officer has reason to believe that the dog threatens the safety of persons or domestic animals, the peace officer may enter upon any premises upon which the dog is kept and remove the dog from those premises to a place of impoundment. Entry onto said premises shall be only with the consent of the person in lawful control of the premises, or after obtaining a search warrant pursuant to law.

**3. Potentially Dangerous Dogs**

~~Proper enclosure for confinement.~~

~~3. All vicious Potentially dangerous dogs. All vicious dogs~~ shall be securely confined within an occupied house or residence or in a securely enclosed and locked pen or kennel, except when leashed ~~as provided in this section or caged for transportation.~~ Also, when such dog is not securely confined or caged for transportation a muzzle shall be placed on the dog. ~~A Such~~ pen, kennel, or structure must have secure sides and a secure top attached to the sides or, in lieu of a top, walls at least six feet in height and at least six inches taller than any internal structure. ~~All pens or other structures designed, constructed or used to confine vicious potentially dangerous dogs must be locked with a key or combination lock when such animals are within the structure. Such structure must have a secure bottom, floor or foundation attached to the sides of the penstructure or the sides of the penstructure must be embedded in the ground no less than two feet so as to prevent digging under the walls by the confined dog. All structures erected to house vicious a potentially dangerous dog dogs must comply with all zoning and building regulations of the City. All such structures must be adequately lighted and ventilated and kept in a clean and sanitary condition. No vicious potentially dangerous dog may be kept on a porch,~~

- Formatted: Strikethrough
- Formatted: Highlight
- Formatted: Strikethrough, Highlight
- Formatted: Highlight
- Formatted: Strikethrough, Highlight
- Formatted: Highlight
- Formatted: Font: (Default) Times New Roman, 12 pt, Highlight, Ligatures: None
- Formatted: Font: (Default) Times New Roman, 12 pt, Ligatures: None
- Formatted: Numbered + Level: 1 + Numbering Style: 1, 2, 3, ... + Start at: 3 + Alignment: Left + Aligned at: 0" + Indent at: 0.25"
- Formatted: Font: (Default) Times New Roman, 12 pt, Highlight, Ligatures: None
- Formatted: Font: (Default) Times New Roman, 12 pt, Highlight, Ligatures: None
- Formatted: Font: (Default) Times New Roman, 12 pt, Highlight, Ligatures: None
- Formatted: List Paragraph, Numbered + Level: 1 + Numbering Style: A, B, C, ... + Start at: 1 + Alignment: Left + Aligned at: 0.25" + Indent at: 0.5"
- Formatted: Font: (Default) Times New Roman, 12 pt, Highlight
- Formatted: Strikethrough, Highlight
- Formatted: Highlight
- Formatted: Font: (Default) Times New Roman, 12 pt, Highlight
- Formatted: Font: (Default) Times New Roman, 12 pt
- Formatted: Line spacing: Multiple 1.08 li, Numbered + Level: 1 + Numbering Style: A, B, C, ... + Start at: 1 + Alignment: Left + Aligned at: 0.25" + Indent at: 0.5"
- Formatted: Font: (Default) Times New Roman, 12 pt, Highlight
- Formatted: ... [1]
- Formatted: Font: (Default) Times New Roman, 12 pt
- Formatted: Font: (Default) Times New Roman, 12 pt
- Formatted: Font: (Default) Times New Roman, 12 pt
- Formatted: Font: (Default) Times New Roman, 12 pt
- Formatted: Font: (Default) Times New Roman, 12 pt
- Formatted: ... [2]
- Formatted: Font: (Default) Times New Roman, 12 pt
- Formatted: Font: (Default) Times New Roman, 12 pt

patio or in any ~~part~~ of a house or structure that would allow the dog to exit such building on its own volition.

A.

B. 4. Leashing. No person shall permit a ~~vicious~~ ~~potentially dangerous dog~~ to go outside its ~~kennel or pen~~ proper enclosure, as described in this section, unless such dog is ~~securely leashed with on a leash~~ no longer than six feet in length. No person shall permit a ~~vicious~~ ~~potentially dangerous dog~~ to be kept on a chain, rope, or other type of leash outside its ~~kennel or pen~~ proper enclosure unless both dog and leash are under the actual physical control of a person 18 years of age or older ~~who has the physical ability to restrain the dog~~. Such dogs may not be leashed to inanimate objects such as trees, posts, buildings, or any other object or structure. ~~Also, when a potentially dangerous dog is not securely confined or caged for transportation, a muzzle shall be placed on the dog.~~

C. At Large. A ~~vicious~~ ~~potentially dangerous~~ dog which is found more than twice ~~in any calendar year~~ not to be confined or leashed as herein required, shall be destroyed by the City pursuant to this chapter, ~~except as provided for "potentially dangerous dogs evaluated for adoption"~~.

D. Potentially dangerous dogs evaluated for adoption. A ~~potentially dangerous dog~~ shall not be destroyed until after it is evaluated for adoption by a contractor. ~~If the contractor determines the dog is not fit for adoption it shall be destroyed. If the contractor determines the dog is fit for adoption, then the dog shall be released to the contractor for adoption to a person who does not reside with the owner at the time of impoundment. If the owner at the time of impoundment or someone residing with the owner is found to have custody, control, or is otherwise harboring the dog after its adoption, the dog shall be immediately impounded and destroyed.~~

~~Warning sign. The owner of a potentially dangerous dog shall post on the premises a clearly visible written warning sign that there is a dangerous dog on the property, and with a conspicuous warning symbol that informs children of the presence of a dangerous dog. The sign shall be very visible from the public roadway or 50 feet, whichever is less.~~

A. 5. At Large. A ~~vicious~~ dog which is found, more than twice ~~in any calendar year~~, not to be confined as herein required, shall be destroyed by the City pursuant to this chapter.

E.

F. 6. Unlicensed. All unlicensed ~~vicious~~ ~~potentially dangerous~~ dogs shall be deemed illegal animals. Said dog will be destroyed by the City pursuant to this chapter, ~~except as provided for "potentially dangerous dogs evaluated for adoption"~~.

#### 4. Dangerous Dogs

A. If after investigation the determination is made that the dog is a dangerous dog, the Chief of Police shall declare such dog to be a dangerous dog and shall order the person owning, sheltering, harboring or keeping the dog to cause it to be destroyed in a humane manner within five days of service of the notice of the order, and keep the dog securely confined or leashed under the actual control of a person 18 years of age or older until so destroyed.

B. Notice that a dog has been declared a dangerous dog shall be promptly served by a peace officer upon an owner of the animal, if known. If notice cannot be promptly served on an

Formatted: Font: (Default) Times New Roman, 12 pt, Highlight

Formatted: Font: Ligatures: Standard + Contextual

Formatted: Font: (Default) Times New Roman, 12 pt, Ligatures: None

Formatted ... [4]

Formatted ... [3]

Formatted ... [5]

Formatted ... [6]

Formatted ... [7]

Formatted ... [8]

Formatted ... [9]

Formatted ... [10]

Formatted ... [11]

Formatted ... [12]

Formatted ... [13]

Formatted: Strikethrough, Highlight

Formatted: Highlight

Formatted: Highlight

Formatted ... [14]

Formatted ... [15]

Formatted: Highlight

Formatted ... [17]

Formatted ... [16]

Formatted ... [18]

Formatted ... [19]

Formatted: Highlight

Formatted ... [20]

Formatted: Font: (Default) Times New Roman, 12 pt

Formatted ... [21]

Formatted: Strikethrough, Highlight

Formatted ... [22]

Formatted: Highlight

Formatted: Highlight

Formatted ... [23]

Formatted ... [24]

Formatted: Highlight

Formatted ... [25]

owner of the dog within the city boundaries, then notice may be served upon any adult residing at the premises where the dog was regularly kept or by posting on those premises if no resident adult is present to accept service. The notice shall include: a description of the dog; a declaration that such dog is a dangerous dog; the basis for such declaration; an order that the owner cause the dog to be destroyed in a humane manner within five days of service of the notice; notice that such dog will be subject to seizure if not destroyed within five days of service of the notice; and notice that the decision to declare the dog a dangerous dog may be appealed.

C. If the dog is ordered to be destroyed by the owner, such order must be complied with within five days of its issuance, otherwise a peace officer is authorized to seize and impound the dog. Such dog may also be seized at any time if it is not actually kept securely confined or leashed under the actual control of a person 18 years of age or older until so destroyed. A dog so seized shall be impounded for a period of seven days, or until seven days after service of the decision on appeal if the decision to declare the dog a dangerous dog is appealed and upheld. If the decision to declare the dog a dangerous dog is reversed on appeal, the dog shall be immediately released to the owner or the owner's representative. However, if at the end of the impoundment period the decision to declare the dog a dangerous dog remains in effect and the owner has not petitioned for a review of such decision, the Chief of Police shall cause the animal to be destroyed in a humane manner.

D. Failure to comply with an order of the Chief of Police issued pursuant to this section and not appealed, or after such order has been affirmed on appeal, shall constitute a misdemeanor offense.

## 75. Appeal Procedures.

### A. Appeal of Vicious, Dangerous or Potentially Dangerous Dog Determination.

(1) Any person who receives an order from the Chief of Police determining that their dog is a vicious, dangerous or potentially dangerous dog may appeal the order by filing a written notice of appeal to the City Administrator within five days of the date of the order. The written appeal shall state the grounds of the appeal.

(2) Upon receiving a notice of appeal, a hearing shall be convened, chaired by the City Administrator or designee, to receive any testimony or other evidence that is deemed appropriate concerning the determination that a dog is a vicious, dangerous or potentially dangerous vicious dog.

(3) When an appeal has been filed, the Chief of Police shall make a reasonable effort to notify any persons who would have had direct involvement in the situation which led to the vicious, dangerous or potentially dangerous vicious dog determination, including those persons who were injured or who are owners or keepers of any animals which were injured by the vicious, dangerous or potentially dangerous vicious dog.

**Formatted:** Font: (Default) Times New Roman, 12 pt, Highlight, Ligatures: None

**Formatted:** Font: (Default) Times New Roman, 12 pt, Highlight, Ligatures: None

**Formatted:** Highlight

**Formatted:** Font: (Default) Times New Roman, 12 pt, Highlight, Ligatures: None

**Formatted:** Font: (Default) Times New Roman, 12 pt, Highlight, Ligatures: None

**Formatted:** Font: (Default) Times New Roman, 12 pt, Highlight, Ligatures: None

**Formatted:** Highlight

**Formatted:** Font: (Default) Times New Roman, 12 pt, Highlight, Ligatures: None

**Formatted:** Font: (Default) Times New Roman, 12 pt, Highlight, Ligatures: None

**Formatted:** Font: (Default) Times New Roman, 12 pt, Highlight, Ligatures: None

**Formatted:** List Paragraph, Indent: Left: 0.25", Numbered + Level: 1 + Numbering Style: A, B, C, ... + Start at: 1 + Alignment: Left + Aligned at: 0.5" + Indent at: 0.75"

**Formatted:** Font: (Default) Times New Roman, 12 pt, Highlight, Ligatures: None

**Formatted:** Line spacing: Multiple 1.08 li

**Formatted:** Strikethrough, Highlight

**Formatted:** Highlight

**Formatted:** Strikethrough, Highlight

**Formatted:** Highlight

**Formatted:** Highlight

**Formatted:** Highlight

**Formatted:** Highlight

(4) The appeal shall be heard by a committee appointed by the City Administrator and consisting of a minimum of three people, including the City Administrator, a member of the public, and one of the following: an animal trainer, a veterinarian, or an animal control professional. Following such hearing, the committee may uphold the decision of the Chief of Police and order the ~~vicious~~ **dangerous or potentially dangerous** ~~vicious~~ dog to be confined as required by the City Code; or modify or reverse the decision of the Chief of Police. The decision and the reasons for it shall be summarized in writing and provided to the person who filed the appeal.

Formatted: Highlight

B. Appeal of Euthanasia Order.

(1) A person who received an order from the Chief of Police requiring that a ~~vicious~~ ~~dangerous or potentially dangerous~~ ~~vicious~~ dog be removed and humanely destroyed as provided in Section ~~55.09(53)~~ or ~~55.09(64)~~ may appeal the order by filing a written notice of appeal to the City Administrator within five days of the date of the order. The written appeal shall state the grounds of the appeal, including how the person proposes to keep the ~~vicious dangerous or~~ ~~potentially dangerous~~ ~~vicious~~ dog in a manner that is in compliance with the standards set out in this chapter, and how the person proposes to reduce the risk of harm that the ~~vicious dangerous~~ ~~or potentially dangerous~~ ~~vicious~~ dog poses to the public.

- Formatted: Highlight
- Formatted: Highlight
- Formatted: Highlight
- Formatted: Highlight

(2) Upon receiving a notice of appeal, a hearing shall be convened, chaired by the City Administrator or designee, to receive any testimony or other evidence that is deemed appropriate concerning the order that the dog be destroyed.

(3) When an appeal has been filed, the Chief of Police shall make a reasonable effort to notify any persons who would have had direct involvement in the situation which led to the order that the dog be destroyed, including those persons who were injured or who are owners or keepers of any animals which were injured by the ~~vicious dangerous or potentially dangerous~~ ~~vicious~~ dog.

Formatted: Highlight

(4) The appeal shall be heard by a committee appointed by the City Administrator and consisting of a minimum of three people, including the City Administrator, a member of the public, and one of the following: an animal trainer, a veterinarian, or an animal control professional. Following such hearing, the committee may uphold the decision of the Chief of Police and order the ~~vicious dangerous or potentially dangerous~~ ~~vicious~~ dog to be destroyed; or modify or reverse the decision of the Chief of Police. The decision and the reasons for it shall be summarized in writing and provided to the person who filed the appeal.

Formatted: Highlight

**55.10 OWNER'S DUTY.**

It is the duty of the owner of any dog, cat, or other animal that has bitten or attacked a person or any person having knowledge of such bite or attack to report this act to a local health or law enforcement official. It is the duty of physicians and veterinarians to report to the local board of health the existence of any animal known or suspected to be suffering from rabies.

*(Code of Iowa, Sec. 351.38)*

**55.11 IMPOUNDING ANIMALS AT LARGE.**

Any animal found at large may be apprehended and impounded by a peace officer. The peace officer shall have the right to enter upon private property when it is necessary to do so in order to apprehend any animal that has been running at large. Such entrance upon private property shall be in reasonable pursuit of the animal(s) and shall not include entry into a domicile unless it be at the invitation of the occupant. If the peace officer determines that the animal at large is dangerous or fierce and a threat to human safety, and that it cannot be safely captured, the animal may be killed.

**55.12 REDEMPTION OF IMPOUNDED ANIMALS.**

When an animal has been apprehended and impounded for being at large or for any other reason, said animal may be redeemed by the owner by a payment of a \$25.00 administrative fee plus

those charges assessed by the clinic or shelter housing the animal. A habitual offender shall be required to pay an additional [\$75] habitual offender impound fee.

Formatted: Highlight

#### **55.13 DISPOSITION OF UNCLAIMED ANIMALS.**

If the unknown owner of an animal apprehended or impounded cannot be located after five days, or if an owner when known, does not, after reasonable notice, claim the animal within five days, the animal may be humanely destroyed or otherwise disposed of. If in the opinion of the peace officer, an animal is too sick or injured to keep humanely for five days, the animal may be euthanized.

Formatted: Highlight

#### **55.14 RIGHT TO KILL UNLICENSED OR LICENSED DOG OR CAT.**

It is lawful for any peace officer or designee of the Mayor to kill any unlicensed dog or cat that is unable to be caught by said peace officer or designee of the Mayor, or to kill any licensed dog or cat when such animal is attacking or attempting to bite a person.

#### **55.15 PET AWARDS PROHIBITED.**

*(Code of Iowa, Ch. 717E)*

1. Prohibition. It is unlawful for any person to award a pet or advertise that a pet may be awarded as any of the following:

- A. A prize for participating in a game.
- B. A prize for participating in a fair.
- C. An inducement or condition for visiting a place of business or attending an event sponsored by a business.
- D. An inducement or condition for executing a contract that includes provisions unrelated to the ownership, care or disposition of the pet.

2. Exceptions. This section does not apply to any of the following:

- A. A pet shop licensed pursuant to Section 162.5 of the *Code of Iowa* if the award of a pet is provided in connection with the sale of a pet on the premises of the pet shop.
- B. Youth programs associated with 4-H Clubs; Future Farmers of America; the Izaak Walton League of America; or organizations associated with outdoor recreation, hunting or fishing, including but not limited to the Iowa Sportsmen's Federation.

#### **55.16 IMMUNIZATION; TAMPERING WITH A RABIES VACCINATION TAG.**

All dogs and cats six months or older shall be vaccinated against rabies. A tag showing evidence of proper vaccination shall be worn by every dog and cat when not confined. It is unlawful to tamper with a rabies vaccination tag.

*(Code of Iowa, Sec. 351.45)*

1. A person commits the offense of tampering with a rabies vaccination tag if all of the following apply:

- A. The person knowingly removes, damages, or destroys a rabies vaccination tag as described in Section 351.35 of the *Code of Iowa*.

B. The rabies vaccination tag is attached to a collar worn by a dog, including as provided in Sections 351.25 and 351.26 of the *Code of Iowa*.

2. This section shall not apply to an act taken by any of the following:

A. The owner of the dog, an agent of the owner, or a person authorized to take action by the owner.

B. A peace officer.

C. A veterinarian.

D. An animal shelter or pound.

*(Section 55.16 – Ord. 400 – Nov. 23 Supp.)*

**55.17 TAMPERING WITH AN ELECTRONIC HANDLING DEVICE.**

It is unlawful to tamper with an electronic handling device.

*(Code of Iowa, Sec. 351.46)*

1. A person commits the offense of tampering with an electronic handling device if all of the following apply:

A. The person knowingly removes, disables, or destroys an electronic device designed and used to maintain custody or control of the dog or modify the dog's behavior.

B. The electronic device is attached to or worn by the dog or attached to an item worn by the dog, including (but not limited to) a collar, harness, or vest.

2. This section shall not apply to an act taken by any of the following:

A. The owner of the dog, an agent of the owner, or a person authorized to take action by the owner.

B. A peace officer.

C. A veterinarian.

D. An animal shelter or pound.

Formatted: Font: (Default) Times New Roman, 12 pt

**Page 7: [1] Formatted** GRACE PETTIT 6/30/2024 9:48:00 PM

Font: (Default) Times New Roman, 12 pt, Highlight

**Page 7: [2] Formatted** GRACE PETTIT 6/30/2024 9:49:00 PM

Font: (Default) Times New Roman, 12 pt, Highlight

**Page 8: [3] Formatted** GRACE PETTIT 6/30/2024 9:15:00 PM

Numbered + Level: 1 + Numbering Style: A, B, C, ... + Start at: 1 + Alignment: Left + Aligned at: 0.25" + Indent at: 0.5"

**Page 8: [4] Formatted** GRACE PETTIT 6/30/2024 9:24:00 PM

Font: (Default) Times New Roman, 12 pt, Ligatures: None

**Page 8: [5] Formatted** GRACE PETTIT 6/30/2024 9:24:00 PM

Font: (Default) Times New Roman, 12 pt, Ligatures: None

**Page 8: [6] Formatted** GRACE PETTIT 6/30/2024 9:51:00 PM

Font: (Default) Times New Roman, 12 pt, Highlight, Ligatures: None

**Page 8: [7] Formatted** GRACE PETTIT 6/30/2024 9:24:00 PM

Font: (Default) Times New Roman, 12 pt, Ligatures: None

**Page 8: [8] Formatted** GRACE PETTIT 6/30/2024 9:24:00 PM

Font: (Default) Times New Roman, 12 pt, Ligatures: None

**Page 8: [9] Formatted** GRACE PETTIT 6/30/2024 9:24:00 PM

Font: (Default) Times New Roman, 12 pt, Ligatures: None

**Page 8: [10] Formatted** GRACE PETTIT 6/30/2024 9:52:00 PM

Font: (Default) Times New Roman, 12 pt, Highlight, Ligatures: None

**Page 8: [11] Formatted** GRACE PETTIT 6/30/2024 9:24:00 PM

Font: (Default) Times New Roman, 12 pt, Ligatures: None

**Page 8: [12] Formatted** GRACE PETTIT 6/30/2024 9:52:00 PM

Font: (Default) Times New Roman, 12 pt, Highlight, Ligatures: None

**Page 8: [13] Formatted** **GRACE PETTIT** **6/30/2024 9:24:00 PM**

Font: (Default) Times New Roman, 12 pt, Ligatures: None

**Page 8: [14] Formatted** **GRACE PETTIT** **7/1/2024 7:59:00 PM**

Font: (Default) Times New Roman, 12 pt, Highlight, Ligatures: None

**Page 8: [15] Formatted** **GRACE PETTIT** **7/1/2024 7:55:00 PM**

Font: (Default) Times New Roman, 12 pt, Ligatures: None

**Page 8: [16] Formatted** **GRACE PETTIT** **6/30/2024 9:15:00 PM**

Numbered + Level: 1 + Numbering Style: A, B, C, ... + Start at: 1 + Alignment: Left + Aligned at: 0.25" + Indent at: 0.5"

**Page 8: [17] Formatted** **GRACE PETTIT** **6/30/2024 9:52:00 PM**

Font: (Default) Times New Roman, 12 pt, Highlight, Ligatures: None

**Page 8: [18] Formatted** **GRACE PETTIT** **6/30/2024 9:52:00 PM**

Font: (Default) Times New Roman, 12 pt, Highlight, Ligatures: None

**Page 8: [19] Formatted** **GRACE PETTIT** **6/30/2024 9:52:00 PM**

Font: (Default) Times New Roman, 12 pt, Highlight, Ligatures: None

**Page 8: [20] Formatted** **GRACE PETTIT** **6/30/2024 9:52:00 PM**

Font: (Default) Times New Roman, 12 pt, Highlight, Ligatures: None

**Page 8: [21] Formatted** **GRACE PETTIT** **6/30/2024 9:24:00 PM**

Font: (Default) Times New Roman, 12 pt, Ligatures: None

**Page 8: [22] Formatted** **GRACE PETTIT** **6/30/2024 9:24:00 PM**

Font: (Default) Times New Roman, 12 pt, Ligatures: None

**Page 8: [23] Formatted** **GRACE PETTIT** **6/30/2024 9:54:00 PM**

Font: (Default) Times New Roman, 12 pt, Highlight, Ligatures: None

**Page 8: [24] Formatted** **GRACE PETTIT** **6/30/2024 9:54:00 PM**

Font: (Default) Times New Roman, 12 pt, Highlight, Ligatures: None

Font: (Default) Times New Roman, 12 pt, Highlight, Ligatures: None

**Adel City Council**  
**June 11, 2024 - Meeting Minutes**

The Adel City Council met in regular session at Adel City Hall, 301 S. 10th Street, Adel, Iowa on Tuesday, June 11, 2024. At 6:01 p.m., Mayor Peters called the meeting to order. The following answered roll: Christensen, McAdon, Selby, and Ockerman. West was absent from the meeting.

Staff Present: City Administrator Brown, Deputy City Administrator/Finance Director Sandquist, City Clerk Erickson, Assistant City Attorney Sabroske, Public Works Director Overton, Fire Chief Nemechek, Police Sergeant Death, Code Compliance Officer Nichols, Parks and Recreation Director Schenck, and Library Director Jayne.

**PUBLIC HEARING**

- 1.a. Public Hearing on Amending the Zoning Ordinance of the City of Adel, Iowa by Repealing and Replacing the Southbridge Plat 8 PUD Ordinance for Property Located at the Intersection of Hwy 169 and Bradfield Street

**Motion by Ockerman, seconded by Christensen, to open the public hearing.**

**Roll: Ayes - Unanimous. Motion Carried.**

*No written or verbal comments were received.*

**Motion by Selby, seconded by McAdon, to close the public hearing.**

**Roll: Ayes - Unanimous. Motion Carried.**

**COMMENTS FROM THE PUBLIC**

- 2.a. Resident(s) of Timberview West Neighborhood Regarding City's Trail Connection Project  
**Valerie Sutton, 931 Lynne Dr, asked the Council to shift the layout of the trail behind her home as much to the south as much as possible while staying as close to the engineer's design as possible. Sutton said that they will pay for any extra fill needed to do so and have spoken with Elder Corporation in conjunction with this request. Mayor Peters responded that if the contractor agrees with this change order, if the cost will be incurred by the property owner, and if this change won't delay the project then the Council would put it up for consideration. Sutton shared that Elder has agreed to hold off the section near her home until the end to give time to figure out the resolution to this request.**

**PRESENTATION**

- 3.a. Presentation of Adel Design Guidelines by Michelle Cunliffe, RDG  
**Rich Hughes, Chair of the Historic Preservation Commission (HPC), introduced Michelle Cunliffe from RDG Planning & Design to present the Adel Design Guidelines. Cunliffe went through the completed design guidelines that the HPC, City Staff, and RDG have been working on for the past couple months. The guidelines cover the history of Adel and the buildings, specific materials and types of architecture that are important to Adel, helpful tips for building owners for how to work with the HPC, standards for rehabilitation, what are the do's and don'ts for what is recommended for each part of the building rehabilitation, and correct materials to use. The Adel Design Guidelines are laid out to make it easy to read and easy to digest.**

**Christensen asked how building owners know that these design guidelines exists and are they forced to read this before they start construction.**

**Hughes responded that Building Inspector Nichols will mention it to building owners before they get a building permit. Cunliffe mentioned that there are even some guidelines for newly constructed buildings to fit in with the historic buildings and not stick out.**

## CONSENT AGENDA

- 4.a. Consider Approval of City Minutes Dated May 14, 2024
  - 4.b. Consider Approval of May Bills and May 31, 2024 Treasurer's Report
  - 4.c. Consider Approval of Class C Retail Alcohol License for Country Lane Lodge - *Pending Dramshop Review*
  - 4.d. Consider Approval of Class B Retail Permit for Family Dollar Stores
  - 4.e. Consider Approval of Class C Retail Alcohol License for The Main Street Adel Chamber of Commerce - Sweet Corn Festival - *Pending Dramshop Review*
  - 4.f. Consider Approval of 2024/2025 Cigarette Permits - Fareway, Adel L&T LLC, Family Dollar
  - 4.g. Consider Approval of Pay Application No. 1 - Adel Evans Park Trail Connections Project
- Motion by Ockerman, seconded by McAdon, to approve the Consent Agenda.**  
**Roll: Ayes - Unanimous. Motion Carried.**

## DEPARTMENT HEAD REPORT

- 5.a. **City Administrator Brown mentioned that McClure Engineering delivered letters to residents that would be impacted by a water main shutoff on Thursday, June 13<sup>th</sup> from 9:00 a.m. to 5:00 p.m. These residents are near the N. 15<sup>th</sup> Street Bridge Replacement project and the water main shutoff is in relation to the project.**

## NEW BUSINESS

- 6.a. Consider Approval of Mayor Board and Commission Appointments: Historic Preservation Commission - Three Openings  
**Motion by Christensen, seconded by McAdon, to appoint Vonzdale Odem and Rich Hughes to the Historic Preservation Commission.**  
**Roll: Ayes - Unanimous. Motion Carried.**
- 6.b. Consider Approval of Council Board and Commission Appointments: Board of Adjustment - One Opening  
**Motion by Ockerman, seconded by Selby, to appoint Dan Novelli to the Board of Adjustment.**  
**Roll: Ayes - Unanimous. Motion Carried.**
- 6.c. Consider Approval of Mayor Board and Commission Appointments: Parks and Recreation Board - Two Openings  
**Motion by McAdon, seconded by Selby, to appoint Deb Bengtson and Maria Steele to the Parks and Recreation Board.**  
**Roll: Ayes - Unanimous. Motion Carried.**
- 6.d. Consider Approval of Council Board and Commission Appointments: Planning & Zoning Commission - One Opening  
**Motion by Ockerman, seconded by McAdon, to appoint Jerry Adams to the Planning & Zoning Commission.**  
**Roll: Ayes - Unanimous. Motion Carried.**
- 6.e. Consider Approval of Mayor Board and Commission Appointments: Library Board - Two Openings  
**Motion by Selby, seconded by McAdon, to appoint Leslie Banwart and Liesl Chaplin to the Library Board.**  
**Roll: Ayes - Unanimous. Motion Carried.**
- 6.f. Consider Approval of Resolution No. 24-37, Approving and Adopting the Adel Design Guidelines Prepared by RDG Planning & Design and Approved by Adel Historic Preservation Commission  
**Motion by Christensen, seconded by McAdon, to approve Resolution No. 24-37.**  
**Roll: Ayes - Unanimous. Motion Carried.**

- 6.g. Consider Approval of RFQ for Engineering Services for Rapids Streets Project  
**Motion by Christensen, seconded by Selby, to approve the RFQ for Engineering Services for the Rapids Street Project.**  
**Roll: Ayes - Unanimous. Motion Carried.**
- 6.h. Consider Approval of Ordinance No. 408, Amending the Zoning Ordinance of the City of Adel, Iowa by Repealing and Replacing the Southbridge Plat 8 PUD Ordinance for Property Located at the Intersection of Hwy 169 and Bradfield Street, City of Adel, Dallas County, Iowa - First Reading  
**Motion by Selby, seconded by McAdon, to approve the first reading of Ordinance No. 408.**  
**Roll: Ayes - Unanimous. Motion Carried.**
- Motion by Ockerman, seconded by Christensen, to waive the second and third readings and adopt Ordinance No. 408.**  
**Roll: Ayes - Unanimous. Motion Carried.**
- 6.i. Consider Approval of Resolution No. 24-38, Approving 2023-2024 Budget Transfers  
**Motion by McAdon, seconded by Christensen, to approve Resolution No. 24-38.**  
**Roll: Ayes - Unanimous. Motion Carried.**

#### **OTHER BUSINESS**

#### **ADJOURNMENT**

**Meeting was adjourned at 6:31 p.m.**

---

James F. Peters, Mayor

Attest: \_\_\_\_\_  
Carrie Erickson, City Clerk

VENDOR NAME	DATE	DESCRIPTION	FUND	DEPARTMENT	AMOUNT_
ACCO	6/27/24	POOL COVERS & VACUUM REPAI	GENERAL FUND	Pool	260.85
	6/27/24	POOL COVERS & VACUUM REPAI	GENERAL FUND	Pool	4,497.27
	6/27/24	CHLORINE- WTR CLARIFIER	GENERAL FUND	Pool	538.75_
				TOTAL:	5,296.87
ADT Security Services	6/27/24	MUSEUM MONITORING 7/11-08/	GENERAL FUND	Museum	61.20_
				TOTAL:	61.20
ASSURITY LIFE INSURANCE COMPANY	6/20/24	PY - ASSURITY PRE TAX	GENERAL FUND	NON-DEPARTMENTAL	20.22
	6/20/24	PY - ASSURITY AFTER TAX	GENERAL FUND	NON-DEPARTMENTAL	32.09
	6/20/24	PY - ASSURITY AFTER TAX	SEWER UTILITY FUND	NON-DEPARTMENTAL	4.62_
				TOTAL:	56.93
Ahlers & Cooney, P.C.	6/27/24	PROF FEES	GENERAL FUND	Finance	2,140.43
	6/27/24	PROF FEES	GENERAL FUND	Zoning/Compliance/Perm	1,579.43
	6/27/24	PROF FEES	ROAD USE TAX	Road Use Tax	158.99_
				TOTAL:	3,878.85
Alley Auto Sales	6/27/24	OIL & FILTER #8	GENERAL FUND	Police Department	54.95
	6/27/24	TIRES FOR 1 TON	GENERAL FUND	Parks	46.00
	6/27/24	TIRES FOR 1 TON	ROAD USE TAX	Road Use Tax	46.00_
				TOTAL:	146.95
Amazon	7/03/24	BATTERY CHARGER	GENERAL FUND	Finance	62.97
	6/27/24	K OVERTON	ROAD USE TAX	Road Use Tax	170.07
	7/03/24	JUNE 2024 PURCHASES	WATER UTILITY	Water	238.31
	7/03/24	JUNE 2024 PURCHASES	SEWER UTILITY FUND	Sewer	941.61
	7/03/24	JUNE 2024 PURCHASES	SEWER UTILITY FUND	Sewer	89.10
	7/03/24	JUNE 2024 PURCHASES	SEWER UTILITY FUND	Sewer	37.43
	6/27/24	M LANSING	SEWER UTILITY FUND	Sewer	356.94_
				TOTAL:	1,896.43
American Express	6/30/24	June '24 Bank & CC Fees	GENERAL FUND	Finance	19.00_
				TOTAL:	19.00
American Red Cross	6/27/24	LIFEGUARD CLASS ( 15 GUAR	GENERAL FUND	Pool	690.00_
				TOTAL:	690.00
Atlantic Bottling Co.	6/27/24	BEVERAGES @ POOL	GENERAL FUND	Pool	444.23_
				TOTAL:	444.23
Aubrey Scieszynski	6/25/24	UMPIRE GAME 6/14	GENERAL FUND	Recreation	45.00_
				TOTAL:	45.00
Authentic Gateway	6/30/24	June '24 Bank & CC Fees	GENERAL FUND	Recreation	12.45_
				TOTAL:	12.45
B-Ham Signs & Designs LLC	6/27/24	BANNER W/ STAND SPECIAL EV	GENERAL FUND	Recreation	374.50_
				TOTAL:	374.50
BBSN Sports	6/27/24	VOLLEY BALL	GENERAL FUND	Recreation	94.50_
				TOTAL:	94.50
Baldon Hardware	7/03/24	JUNE 2024 SUPP/PURCHASES	ROAD USE TAX	Road Use Tax	187.28
	7/03/24	JUNE 2024 SUPP/PURCHASES	SEWER UTILITY FUND	Sewer	107.76_
				TOTAL:	295.04

VENDOR NAME	DATE	DESCRIPTION	FUND	DEPARTMENT	AMOUNT_
BankCard	6/30/24	June '24 Bank & CC Fees	GENERAL FUND	Recreation	1,123.51_
				TOTAL:	1,123.51
Base	6/30/24	June '24 HRA & Flex Reim	TRUST AND AGENCY	General Government	4,578.16
	6/30/24	June '24 HRA & Flex Reim	TRUST AND AGENCY	General Government	495.00
	6/30/24	June '24 HRA & Flex Reim	TRUST AND AGENCY	General Government	75.84
	6/30/24	June '24 HRA & Flex Reim	WATER UTILITY	Water	2,326.21
	6/30/24	June '24 HRA & Flex Reim	SEWER UTILITY FUND	Sewer	468.51
	6/30/24	June '24 HRA & Flex Reim	STORM WATER UTILIT	STORM WATER UTILITY	11.05_
				TOTAL:	7,954.77
Behr Construction Homes	6/27/24	KF RESTROOM	GENERAL FUND	Parks	3,915.47_
				TOTAL:	3,915.47
Blank Park Zoo	6/27/24	ADV PASS	GENERAL FUND	Library	250.00_
				TOTAL:	250.00
Bohlmann Inc	6/27/24	NOZZLE FOR WTR FOUNTAIN	GENERAL FUND	Parks	197.71_
				TOTAL:	197.71
Book System Inc	6/27/24	ANNUAL ALS SUBSCRIPTION RE	GENERAL FUND	Library	1,990.00_
				TOTAL:	1,990.00
Bound Tree Medical	6/27/24	MEDICAL SUPPLIES-FIRE	GENERAL FUND	Fire Department	936.47_
				TOTAL:	936.47
Bunn-O-Matic Corp	6/27/24	PARTS FOR GATOR ICE MACHIN	GENERAL FUND	Pool	501.64_
				TOTAL:	501.64
CAMS	7/03/24	CLEANING-WTR PLANT-JUL 202	WATER UTILITY	Water	625.00_
				TOTAL:	625.00
CITY OF ADEL (FLEX SPENDING ACCOUNTS)	6/20/24	PY-FLEX SPENDING W/H	GENERAL FUND	NON-DEPARTMENTAL	129.71
	6/20/24	PY-DCAP W/H	GENERAL FUND	NON-DEPARTMENTAL	64.76
	6/20/24	PY-FLEX SPENDING W/H	ROAD USE TAX	NON-DEPARTMENTAL	23.05
	6/20/24	PY-DCAP W/H	ROAD USE TAX	NON-DEPARTMENTAL	20.80
	6/20/24	PY-FLEX SPENDING W/H	WATER UTILITY	NON-DEPARTMENTAL	32.80
	6/20/24	PY-DCAP W/H	WATER UTILITY	NON-DEPARTMENTAL	31.20
	6/20/24	PY-FLEX SPENDING W/H	SEWER UTILITY FUND	NON-DEPARTMENTAL	57.48
	6/20/24	PY-DCAP W/H	SEWER UTILITY FUND	NON-DEPARTMENTAL	31.20
	6/20/24	PY-FLEX SPENDING W/H	STORM WATER UTILIT	NON-DEPARTMENTAL	2.46
	6/20/24	PY-DCAP W/H	STORM WATER UTILIT	NON-DEPARTMENTAL	1.04_
				TOTAL:	394.50
Camden Wilson	6/25/24	UMPIRE GAME 6/3,6/6,6/6,&	GENERAL FUND	Recreation	180.00_
				TOTAL:	180.00
Capital City Equipment Co	6/27/24	GASKET KIT FOR MOWER	GENERAL FUND	Parks	34.66_
				TOTAL:	34.66
Capital Sanitary Supply	6/27/24	ROLL TOWELS	WATER UTILITY	Water	43.20_
				TOTAL:	43.20
Center Point Large Print	6/27/24	LARGE PRINT BOOK	GENERAL FUND	Library	2,373.12_
				TOTAL:	2,373.12

VENDOR NAME	DATE	DESCRIPTION	FUND	DEPARTMENT	AMOUNT_
CenturyLink	7/03/24	PH SERV 6/19-7/15/2024	WATER UTILITY	Water	70.46_
				TOTAL:	70.46
Chris Alter	7/02/24	POPCORN POPPER	GENERAL FUND	Pool	300.00_
				TOTAL:	300.00
Cintas Corporation	6/27/24	MED KIT SERVICE	ROAD USE TAX	Road Use Tax	23.20
	6/27/24	MED KIT SERVICE	WATER UTILITY	Water	23.20
	6/27/24	MED KIT SERVICE	SEWER UTILITY FUND	Sewer	23.20_
				TOTAL:	69.60
Cole Darling	6/25/24	UMPIRE GAME 6/17	GENERAL FUND	Recreation	65.00_
				TOTAL:	65.00
Collections Services Center	6/20/24	CHILD SUPPORT W/H	ROAD USE TAX	NON-DEPARTMENTAL	206.10
	6/20/24	CHILD SUPPORT W/H	STORM WATER UTILIT	NON-DEPARTMENTAL	22.90_
				TOTAL:	229.00
Concrete Impressions	6/27/24	CONCRETE PROJECT @ CH	GENERAL FUND	Finance	58,093.00_
				TOTAL:	58,093.00
Core & Main LP	6/27/24	HYD TRAFFIC KITS	WATER UTILITY	Water	1,227.66
	6/27/24	SHEARING RING	SEWER UTILITY FUND	Sewer	150.66
	6/27/24	SEWER- PARTS/SUPPLIES	SEWER UTILITY FUND	Sewer	19,692.65_
				TOTAL:	21,070.97
Core-Mark Midcontinent, Inc.	6/27/24	FOOD @ POOL	GENERAL FUND	Pool	2,796.06
	6/27/24	FOOD @ POOL	GENERAL FUND	Pool	2,369.68
	6/27/24	AQUATIC CENTER-CONCESSIONS	GENERAL FUND	Pool	1,706.51_
				TOTAL:	6,872.25
Creative Services of New England	7/03/24	PD BADGES- STICKERS	TRUST AND AGENCY	Police	320.95_
				TOTAL:	320.95
Culligan	6/27/24	WTR COOLER RENTAL	GENERAL FUND	Pool	27.30_
				TOTAL:	27.30
Cultureall	6/27/24	SR SPEAKER FEES	FRIENDS/FOUNDATION	Library	240.00_
				TOTAL:	240.00
Curtis Waddingham	6/27/24	REIMBURSEMENT ON PERSONAL	GENERAL FUND	Parks	85.71
	7/03/24	CLOTHING REIMBURSE-SHORTS	GENERAL FUND	Parks	47.04_
				TOTAL:	132.75
Dallas County Data	7/03/24	JUL1-JUL31 2024 INT SERV	GENERAL FUND	Pool	99.99_
				TOTAL:	99.99
Dallas County Treasurer	7/03/24	PARKING TCKT FEE	GENERAL FUND	Police Department	5.00_
				TOTAL:	5.00
Danko Emergency Equipment	6/27/24	FIRE PANTS	GENERAL FUND	Fire Department	978.87
	7/03/24	FD- BUNKER GEAR- UTHE	GENERAL FUND	Fire Department	2,216.00
	6/27/24	FIRE GLOVED & HOOD. FOAM W	GENERAL FUND	Fire Department	2,891.00_
				TOTAL:	6,085.87
Davis Equipment Corp.	6/27/24	MOWER WHEEL, BEARING & BLA	GENERAL FUND	Parks	641.39

VENDOR NAME	DATE	DESCRIPTION	FUND	DEPARTMENT	AMOUNT_
				TOTAL:	641.39
Delta Dental Plan of Iowa	6/20/24	PY-INSURANCE PREMIUM DELTA	GENERAL FUND	NON-DEPARTMENTAL	199.25
	6/20/24	PY-INSURANCE PREMIUM DELTA	ROAD USE TAX	NON-DEPARTMENTAL	23.99
	6/27/24	JULY 24 DENTAL PREMIUM	ROAD USE TAX	Road Use Tax	299.12
	6/27/24	JULY 24 DENTAL PREMIUM	TRUST AND AGENCY	General Government	1,713.13
	6/20/24	PY-INSURANCE PREMIUM DELTA	WATER UTILITY	NON-DEPARTMENTAL	29.06
	6/27/24	JULY 24 DENTAL PREMIUM	WATER UTILITY	Water	326.31
	6/20/24	PY-INSURANCE PREMIUM DELTA	SEWER UTILITY FUND	NON-DEPARTMENTAL	21.66
	6/27/24	JULY 24 DENTAL PREMIUM	SEWER UTILITY FUND	Sewer	353.50
	6/20/24	PY-INSURANCE PREMIUM DELTA	STORM WATER UTILIT	NON-DEPARTMENTAL	2.75
	6/27/24	JULY 24 DENTAL PREMIUM	STORM WATER UTILIT	STORM WATER UTILITY	27.19
				TOTAL:	2,995.96
Delta Dental of Iowa (Vision)	6/20/24	PY-INSURANCE PREMIUM VISIO	GENERAL FUND	NON-DEPARTMENTAL	16.04
	6/20/24	PY-INSURANCE PREMIUM VISIO	ROAD USE TAX	NON-DEPARTMENTAL	2.07
	6/20/24	PY-INSURANCE PREMIUM VISIO	WATER UTILITY	NON-DEPARTMENTAL	3.10
	6/20/24	PY-INSURANCE PREMIUM VISIO	SEWER UTILITY FUND	NON-DEPARTMENTAL	2.49
	6/20/24	PY-INSURANCE PREMIUM VISIO	STORM WATER UTILIT	NON-DEPARTMENTAL	0.24
				TOTAL:	23.94
Des Moines Public Library	6/27/24	LOST ILL BOOK	GENERAL FUND	Library	27.00
				TOTAL:	27.00
Des Moines Steel	6/27/24	GATES @ ISLAND PARK FENCE	GENERAL FUND	Parks	2,870.00
				TOTAL:	2,870.00
Doug Cook	6/27/24	CONCRETE FROM & DIGITAL LE	ROAD USE TAX	Road Use Tax	1,450.00
				TOTAL:	1,450.00
Elder Corporation	6/13/24	CIRTPA Trail Project	CIRTPA TRAILS	CAPITAL PROJECTS	10,308.95
				TOTAL:	10,308.95
Elite Electric & Utility Contractors	6/27/24	ELETRICALLY WORK & LIGHTIN	GENERAL FUND	Parks	26,408.20
	6/27/24	ELETRICALLY WORK & LIGHTIN	GENERAL FUND	Parks	1,177.10
				TOTAL:	27,585.30
Feld Fire Equip. Co.	6/27/24	#102 FOAM EDUCATOR & NOZ	GENERAL FUND	Fire Department	1,717.06
	6/27/24	VALVE REPAIR KIT	GENERAL FUND	Fire Department	206.61
				TOTAL:	1,923.67
Ferguson Waterworks #2516	6/27/24	METERS	WATER UTILITY	Water	41,040.00
	6/27/24	NEPTUNE 360 SOFTWARE	WATER UTILITY	Water	698.80
				TOTAL:	41,738.80
Gannett Iowa LocaliQ	6/27/24	PUBLIC NOTICE	GENERAL FUND	Police Department	11.40
				TOTAL:	11.40
Grayson Sutter	6/25/24	UMPIRE GAME 5/31 & 6/4	GENERAL FUND	Recreation	90.00
				TOTAL:	90.00
HQI- Hydraulics	6/27/24	HOSE PARTS & ASSEMBLY	ROAD USE TAX	Road Use Tax	1,059.34
				TOTAL:	1,059.34
Harn R/O	6/27/24	CHEMICAL	WATER UTILITY	Water	5,960.00
				TOTAL:	5,960.00

VENDOR NAME	DATE	DESCRIPTION	FUND	DEPARTMENT	AMOUNT
Hawkins Inc.	6/27/24	AZONE 15	WATER UTILITY	Water	4,137.49
				TOTAL:	4,137.49
Heiman Inc	6/27/24	NOZZLE ASSEMBLY #102	GENERAL FUND	Fire Department	4,195.00
				TOTAL:	4,195.00
Hercules Tow Ropes Inc	6/27/24	ROPES @ POOL	GENERAL FUND	Pool	4,144.13
				TOTAL:	4,144.13
Hi-Viz Safety	6/27/24	TRAFFIC CONES & SAFTY GLAS	SEWER UTILITY FUND	Sewer	358.00
	6/27/24	M.LANSING	SEWER UTILITY FUND	Sewer	209.00
	6/27/24	C. FREEMYER	SEWER UTILITY FUND	Sewer	114.00
				TOTAL:	681.00
IOWA RETIREMENT INVESTORS' CLUB (RIC)	6/20/24	RIC PRETAX CONTRIBUTION	GENERAL FUND	NON-DEPARTMENTAL	166.50
	6/20/24	RIC ROTH CONTRIBUTION	GENERAL FUND	NON-DEPARTMENTAL	282.00
	6/20/24	RIC PRETAX CONTRIBUTION	ROAD USE TAX	NON-DEPARTMENTAL	70.00
	6/20/24	RIC ROTH CONTRIBUTION	ROAD USE TAX	NON-DEPARTMENTAL	191.67
	6/20/24	RIC PRETAX CONTRIBUTION	WATER UTILITY	NON-DEPARTMENTAL	105.00
	6/20/24	RIC ROTH CONTRIBUTION	WATER UTILITY	NON-DEPARTMENTAL	287.50
	6/20/24	RIC PRETAX CONTRIBUTION	SEWER UTILITY FUND	NON-DEPARTMENTAL	105.00
	6/20/24	RIC ROTH CONTRIBUTION	SEWER UTILITY FUND	NON-DEPARTMENTAL	287.50
	6/20/24	RIC ROTH % CONTRIBUTION	SEWER UTILITY FUND	NON-DEPARTMENTAL	389.57
	6/20/24	RIC PRETAX CONTRIBUTION	STORM WATER UTILIT	NON-DEPARTMENTAL	3.50
	6/20/24	RIC ROTH CONTRIBUTION	STORM WATER UTILIT	NON-DEPARTMENTAL	9.58
				TOTAL:	1,897.90
IPERS	6/20/24	PY-IPERS REG	GENERAL FUND	NON-DEPARTMENTAL	1,983.11
	6/20/24	PY-POLICE IPERS	GENERAL FUND	NON-DEPARTMENTAL	1,943.50
	6/20/24	PY-IPERS REG	ROAD USE TAX	NON-DEPARTMENTAL	613.34
	6/20/24	PY-IPERS REG	ROAD USE TAX	Road Use Tax	920.48
	6/20/24	PY-IPERS REG	TRUST AND AGENCY	General Government	3,026.81
	6/20/24	PY-POLICE IPERS	TRUST AND AGENCY	General Government	2,913.68
	6/20/24	PY-IPERS REG	WATER UTILITY	NON-DEPARTMENTAL	886.73
	6/20/24	PY-IPERS REG	WATER UTILITY	Water	1,330.80
	6/20/24	PY-IPERS REG	SEWER UTILITY FUND	NON-DEPARTMENTAL	947.11
	6/20/24	PY-IPERS REG	SEWER UTILITY FUND	Sewer	1,421.40
	6/20/24	PY-IPERS REG	STORM WATER UTILIT	NON-DEPARTMENTAL	61.40
	6/20/24	PY-IPERS REG	STORM WATER UTILIT	STORM WATER UTILITY	92.16
				TOTAL:	16,140.52
Infomax Office Systems Inc	6/27/24	COPIER LEASE & SIGNAGE	GENERAL FUND	Library	379.39
				TOTAL:	379.39
Iowa DNR	7/03/24	ANN WTR SUPP FEE FY25	WATER UTILITY	Water	708.00
				TOTAL:	708.00
Iowa History Journal	6/27/24	MAGAZINE	GENERAL FUND	Library	35.95
				TOTAL:	35.95
Iowa League of Cities	6/27/24	MEMBER DUE 7/24-6/25	GENERAL FUND	Finance	3,284.00
				TOTAL:	3,284.00
Jetco, Inc.	6/27/24	RADIO/ANTENNAE SRVC	WATER UTILITY	Water	2,975.75
				TOTAL:	2,975.75

VENDOR NAME	DATE	DESCRIPTION	FUND	DEPARTMENT	AMOUNT_
Joel Delaney	6/27/24	MEAL REIMBURSEMENT @ CONF	GENERAL FUND	Police Department	120.46_
				TOTAL:	120.46
Johnson Controls	6/27/24	ALARM SYSTEM REPAIR & REPL	GENERAL FUND	Library	2,177.01_
				TOTAL:	2,177.01
Justin Zika	6/27/24	J ZIKA BOOT REIMBURSEMENT	ROAD USE TAX	Road Use Tax	217.95_
				TOTAL:	217.95
KLINGNER & ASSOCIATES, P.C.	7/03/24	STRUCTUAL EVAL OF BLDG	GENERAL FUND	Zoning/Compliance/Perm	3,099.33_
				TOTAL:	3,099.33
Karl Chevrolet	6/27/24	2024 CHEVY 1500 WTR TRUCK	WATER UTILITY	Water	29,648.70_
				TOTAL:	29,648.70
Keystone Laboratories, Inc.	7/03/24	JUNE 2024- MONTH TEST	WATER UTILITY	Water	1,224.25
	7/03/24	JUNE 2024- MONTH TEST	SEWER UTILITY FUND	Sewer	1,404.00_
				TOTAL:	2,628.25
King's Material	6/27/24	70 BAGS OF MULCH	GENERAL FUND	Parks	645.56_
				TOTAL:	645.56
Lenhart Plumbing Inc.	6/27/24	REPLACE YARD HYDRANT	GENERAL FUND	Parks	1,526.30_
				TOTAL:	1,526.30
Linda Johnson	7/03/24	JUN 2024- CLEANING	GENERAL FUND	Police Department	360.00
	7/03/24	JUN 2024- CLEANING	GENERAL FUND	Finance	513.00_
				TOTAL:	873.00
Logan Contractors Supply Inc	6/27/24	CONCRETE TOOLS	ROAD USE TAX	Road Use Tax	291.95_
				TOTAL:	291.95
Logoed Apparel & Promotions	6/27/24	OFFICE STAFF CLOTHING ALLO	GENERAL FUND	Finance	52.22
	6/27/24	J ZIKA CLOTHING ALLOWANCE	ROAD USE TAX	Road Use Tax	49.99
	6/27/24	OFFICE STAFF CLOTHING ALLO	ROAD USE TAX	Road Use Tax	52.22
	6/27/24	OFFICE STAFF CLOTHING ALLO	WATER UTILITY	Water	52.22
	6/27/24	G.GOEDEN CLOTHING ALLOWANC	WATER UTILITY	Water	64.92_
				TOTAL:	271.57
Luellen Enterprises	6/27/24	NEW LIGHT POLE @ KF PARK	GENERAL FUND	Parks	4,225.37_
				TOTAL:	4,225.37
MSA Professional Services Inc.	6/27/24	SENSORS	SEWER UTILITY FUND	Sewer	439.00_
				TOTAL:	439.00
MacQueen Equipment	6/27/24	POWER SUPPLIES FOR TRAILER	SEWER UTILITY FUND	Sewer	375.07_
				TOTAL:	375.07
Mainstay Systems Inc.	6/27/24	QUARTERLY SERVICE	GENERAL FUND	Parks	259.71
	6/27/24	QUARTERLY SERVICE	GENERAL FUND	Recreation	259.71
	6/27/24	QUARTERLY SERVICE	GENERAL FUND	Finance	259.71
	6/27/24	QUARTERLY SERVICE	GENERAL FUND	Zoning/Compliance/Perm	259.71
	6/27/24	QUARTERLY SERVICE	ROAD USE TAX	Road Use Tax	259.71
	6/27/24	QUARTERLY SERVICE	WATER UTILITY	Water	259.72
	6/27/24	COMPUTER @ WWTP	SEWER UTILITY FUND	Sewer	3,216.00
	6/27/24	QUARTERLY SERVICE	SEWER UTILITY FUND	Sewer	259.72

VENDOR NAME	DATE	DESCRIPTION	FUND	DEPARTMENT	AMOUNT_
				TOTAL:	5,034.00
Manatts Inc.	6/27/24	STREET PATCH	ROAD USE TAX	Road Use Tax	2,332.00_
				TOTAL:	2,332.00
Martin Marietta Materials	6/28/24	1 INCH ROAD STONE	GENERAL FUND	Parks	998.81
	6/28/24	1 INCH ROAD STONE	GENERAL FUND	Recreation	998.82
	6/27/24	ROCK @ SHOP	ROAD USE TAX	Road Use Tax	488.01_
				TOTAL:	2,485.64
McClure Engineering Company	7/03/24	PROF SRVS 5/26-6/29	GENERAL FUND	Zoning/Compliance/Perm	3,482.50
	7/03/24	PROF SRVS 5/26-6/29	NEW WASTEWTR TRTMN	CAPITAL PROJECTS	15,870.00
	7/03/24	PROF SRVS 5/26-6/29	WATER UTIL IMPROV	CAPITAL PROJECTS	6,968.41
	7/03/24	PROF SRVS 5/26-6/29	N 15TH ST BRIDGE R	CAPITAL PROJECTS	12,222.07
	7/03/24	PROF SRVS 5/26-6/29	CIRTPA TRAILS	CAPITAL PROJECTS	50,465.10
	7/03/24	PROF SRVS 5/26-6/29	CHANNEL STABILIZAT	CAPITAL PROJECTS	1,760.70
	7/03/24	PROF SRVS 5/26-6/29	SEWER UTILITY FUND	Sewer	5,581.25_
				TOTAL:	96,350.03
McKenzie Kiger	6/27/24	WTR SAFETY INSTRUSTOR CLAS	GENERAL FUND	Pool	2,000.00_
				TOTAL:	2,000.00
Mediacom	6/27/24	INTERNET@ WTP	WATER UTILITY	Water	304.06_
				TOTAL:	304.06
Menards	6/27/24	LUMBER TO FIX SB DUGOUTS	GENERAL FUND	Recreation	162.41
	6/27/24	MULCH @ LIBRARY	GENERAL FUND	Finance	59.55
	6/27/24	SUPPLIES	ROAD USE TAX	Road Use Tax	19.99
	7/03/24	SUPPLIES DUSTER/HANDLE	ROAD USE TAX	Road Use Tax	47.93_
				TOTAL:	289.88
Menards-Grimes	6/27/24	TAPCON SCREWS & CARPET TIL	GENERAL FUND	Parks	347.18_
				TOTAL:	347.18
Monte Keller	6/27/24	MEAL REIMBURSEMENT @ CONF	GENERAL FUND	Police Department	16.00_
				TOTAL:	16.00
Moss Brothers Inc	6/27/24	REAR WINDOW & PARTS MF TRA	ROAD USE TAX	Road Use Tax	561.71_
				TOTAL:	561.71
Murphy Tractor & Equipment Co	6/27/24	OIL FOR MINI 50 GALLON	ROAD USE TAX	Road Use Tax	150.94_
				TOTAL:	150.94
PRINCIPAL LIFE INSURANCE CO - SBD GRAN	6/20/24	PY - PRINCIPAL VOLUNTARY L	GENERAL FUND	NON-DEPARTMENTAL	225.04
	6/20/24	PY - PRINCIPAL VOLUNTARY L	ROAD USE TAX	NON-DEPARTMENTAL	8.07
	6/27/24	JULY 24 LIFE & DISABLILITY	TRUST AND AGENCY	General Government	1,033.38
	6/20/24	PY - PRINCIPAL VOLUNTARY L	WATER UTILITY	NON-DEPARTMENTAL	11.29
	6/27/24	JULY 24 LIFE & DISABLILITY	WATER UTILITY	Water	189.21
	6/20/24	PY - PRINCIPAL VOLUNTARY L	SEWER UTILITY FUND	NON-DEPARTMENTAL	26.99
	6/27/24	JULY 24 LIFE & DISABLILITY	SEWER UTILITY FUND	Sewer	218.32
	6/20/24	PY - PRINCIPAL VOLUNTARY L	STORM WATER UTILIT	NON-DEPARTMENTAL	0.79
	6/27/24	JULY 24 LIFE & DISABLILITY	STORM WATER UTILIT	STORM WATER UTILITY	14.55_
				TOTAL:	1,727.64
Paul's Pest Control	7/03/24	PEST CONTROL SPRAY	GENERAL FUND	Police Department	80.00
	7/03/24	PEST CONTROL SPRAY	GENERAL FUND	Museum	70.00

VENDOR NAME	DATE	DESCRIPTION	FUND	DEPARTMENT	AMOUNT_
	7/03/24	PEST CONTROL SPRAY	GENERAL FUND	Finance	70.00_
				TOTAL:	220.00
People's Bank	6/20/24	PY-STATE W/H	GENERAL FUND	NON-DEPARTMENTAL	2,419.59
	6/30/24	June '24 Bank & CC Fees	GENERAL FUND	Finance	70.00
	6/20/24	PY-STATE W/H	ROAD USE TAX	NON-DEPARTMENTAL	331.08
	6/20/24	PY-STATE W/H	WATER UTILITY	NON-DEPARTMENTAL	536.78
	6/20/24	PY-STATE W/H	SEWER UTILITY FUND	NON-DEPARTMENTAL	636.61
	6/20/24	PY-STATE W/H	STORM WATER UTILIT	NON-DEPARTMENTAL	31.94_
				TOTAL:	4,026.00
Peoples Trust & Savings	6/20/24	PY-W/H FED TAXES	GENERAL FUND	NON-DEPARTMENTAL	4,305.35
	6/20/24	PY-FICA W/H & MATCH	GENERAL FUND	NON-DEPARTMENTAL	5,788.19
	6/20/24	PY-MC W/H & MATCH	GENERAL FUND	NON-DEPARTMENTAL	1,353.72
	6/20/24	PY-W/H FED TAXES	ROAD USE TAX	NON-DEPARTMENTAL	902.79
	6/20/24	PY-FICA W/H & MATCH	ROAD USE TAX	NON-DEPARTMENTAL	571.88
	6/20/24	PY-MC W/H & MATCH	ROAD USE TAX	NON-DEPARTMENTAL	133.73
	6/20/24	PY-FICA W/H & MATCH	ROAD USE TAX	Road Use Tax	571.89
	6/20/24	PY-MC W/H & MATCH	ROAD USE TAX	Road Use Tax	133.74
	6/20/24	PY-FICA W/H & MATCH	TRUST AND AGENCY	General Government	5,788.22
	6/20/24	PY-MC W/H & MATCH	TRUST AND AGENCY	General Government	1,353.71
	6/20/24	PY-W/H FED TAXES	WATER UTILITY	NON-DEPARTMENTAL	1,417.11
	6/20/24	PY-FICA W/H & MATCH	WATER UTILITY	NON-DEPARTMENTAL	858.46
	6/20/24	PY-MC W/H & MATCH	WATER UTILITY	NON-DEPARTMENTAL	200.77
	6/20/24	PY-FICA W/H & MATCH	WATER UTILITY	Water	858.47
	6/20/24	PY-MC W/H & MATCH	WATER UTILITY	Water	200.78
	6/20/24	PY-W/H FED TAXES	SEWER UTILITY FUND	NON-DEPARTMENTAL	1,589.65
	6/20/24	PY-FICA W/H & MATCH	SEWER UTILITY FUND	NON-DEPARTMENTAL	912.74
	6/20/24	PY-MC W/H & MATCH	SEWER UTILITY FUND	NON-DEPARTMENTAL	213.48
	6/20/24	PY-FICA W/H & MATCH	SEWER UTILITY FUND	Sewer	912.73
	6/20/24	PY-MC W/H & MATCH	SEWER UTILITY FUND	Sewer	213.47
	6/20/24	PY-W/H FED TAXES	STORM WATER UTILIT	NON-DEPARTMENTAL	82.80
	6/20/24	PY-FICA W/H & MATCH	STORM WATER UTILIT	NON-DEPARTMENTAL	57.19
	6/20/24	PY-MC W/H & MATCH	STORM WATER UTILIT	NON-DEPARTMENTAL	13.37
	6/20/24	PY-FICA W/H & MATCH	STORM WATER UTILIT	STORM WATER UTILITY	57.15
	6/20/24	PY-MC W/H & MATCH	STORM WATER UTILIT	STORM WATER UTILITY	13.37_
				TOTAL:	28,504.76
Plumb Supply Co	6/27/24	SHOWERHEAD-POOL	GENERAL FUND	Pool	72.43
	6/27/24	SWR SUPPLIES	SEWER UTILITY FUND	Sewer	143.06_
				TOTAL:	215.49
Premier Pest Control	7/03/24	MOSQUITO SPRAY 6/2024	STORM WATER UTILIT	STORM WATER UTILITY	1,000.00_
				TOTAL:	1,000.00
Public Financial Management, Inc.	7/03/24	FIN ADV- ANNUAL RETAINER F	GENERAL FUND	Finance	1,600.00
	7/03/24	FIN ADV- ANNUAL RETAINER F	ROAD USE TAX	Road Use Tax	1,600.00
	7/03/24	FIN ADV- ANNUAL RETAINER F	WATER UTILITY	Water	1,600.00
	7/03/24	FIN ADV- ANNUAL RETAINER F	SEWER UTILITY FUND	Sewer	1,600.00
	7/03/24	FIN ADV- ANNUAL RETAINER F	STORM WATER UTILIT	STORM WATER UTILITY	1,600.00_
				TOTAL:	8,000.00
Rhiner's Services	6/27/24	BREAKER RE-SET	GENERAL FUND	Pool	169.60_
				TOTAL:	169.60
Ricoh USA, Inc.	6/27/24	PRINTER LEASE 6/29-7/28	GENERAL FUND	Police Department	138.34

VENDOR NAME	DATE	DESCRIPTION	FUND	DEPARTMENT	AMOUNT_
	7/03/24	COPIER RENT	GENERAL FUND	Recreation	27.88
	7/03/24	COPIER RENT	GENERAL FUND	Finance	27.88
	7/03/24	COPIER RENT	GENERAL FUND	Zoning/Compliance/Perm	27.87
	7/03/24	COPIER RENT	ROAD USE TAX	Road Use Tax	27.88
	7/03/24	COPIER RENT	WATER UTILITY	Water	27.88
	7/03/24	COPIER RENT	SEWER UTILITY FUND	Sewer	27.88_
				TOTAL:	305.61
Rockmount Research & Alloys Inc	6/27/24	WELDING SUPPLIES & MISC	ROAD USE TAX	Road Use Tax	250.06
	6/27/24	WELDING SUPPLIES & MISC	WATER UTILITY	Water	250.06
	6/27/24	WELDING SUPPLIES & MISC	SEWER UTILITY FUND	Sewer	250.06
	6/27/24	WELDING SUPPLIES & MISC	STORM WATER UTILIT	STORM WATER UTILITY	250.06_
				TOTAL:	1,000.24
SCI Communication	6/27/24	ONSITE TECH	WATER UTILITY	Water	300.00_
				TOTAL:	300.00
SSI Specialties, Inc	6/27/24	LITTLE SLUGGER SHIRTS	GENERAL FUND	Recreation	366.23
	6/27/24	LITTLE SLUGGER SHIRTS	GENERAL FUND	Recreation	366.24_
				TOTAL:	732.47
Schwinger Lawn Service Inc	6/27/24	TREE TRIM & REMOVAL	GENERAL FUND	Parks	2,654.00
	6/27/24	TREE TRIM & REMOVAL	GENERAL FUND	Parks	5,525.00
	6/27/24	TREE TRIM & REMOVAL	ROAD USE TAX	Road Use Tax	1,400.00_
				TOTAL:	9,579.00
Shottenkirk Chevrolet	6/27/24	DIAGNOSIS & REPAIR STARTER	GENERAL FUND	Police Department	1,036.21_
				TOTAL:	1,036.21
Sprayer Specialties Inc.	6/27/24	300 GAL SPRAYER	GENERAL FUND	Parks	5,400.00_
				TOTAL:	5,400.00
Staples Advantage	7/03/24	STAPLES ADVAN PURCHASES	GENERAL FUND	Police Department	64.06
	7/03/24	STAPLES ADVAN PURCHASES	GENERAL FUND	Parks	39.73
	7/03/24	STAPLES ADVAN PURCHASES	GENERAL FUND	Recreation	39.74
	7/03/24	STAPLES ADVAN PURCHASES	GENERAL FUND	Finance	39.74
	7/03/24	STAPLES ADVAN PURCHASES	GENERAL FUND	Zoning/Compliance/Perm	39.74
	7/03/24	STAPLES ADVAN PURCHASES	ROAD USE TAX	Road Use Tax	39.73
	7/03/24	STAPLES ADVAN PURCHASES	WATER UTILITY	Water	39.73
	7/03/24	STAPLES ADVAN PURCHASES	SEWER UTILITY FUND	Sewer	39.73_
				TOTAL:	342.20
State Hygienic Laboratory	6/27/24	WTR TESTING @ POOL	GENERAL FUND	Pool	14.50_
				TOTAL:	14.50
Stivers Ford Inc	6/27/24	REPAIR/REPLACE CAMERA	GENERAL FUND	Police Department	843.50
	6/27/24	DIAGNOS & REPAIR LIGHTING	GENERAL FUND	Police Department	435.27_
				TOTAL:	1,278.77
Swank Movie Licensing USA	6/27/24	JUNE 24 MEETING	GENERAL FUND	Recreation	465.00_
				TOTAL:	465.00
T-Mobile	7/03/24	SRVCS 5/21-6/20	GENERAL FUND	Parks	87.63
	7/03/24	SRVCS 5/21-6/20	GENERAL FUND	Pool	14.60
	7/03/24	SRVCS 5/21-6/20	GENERAL FUND	Recreation	43.82
	7/03/24	SRVCS 5/21-6/20	GENERAL FUND	Finance	29.21

VENDOR NAME	DATE	DESCRIPTION	FUND	DEPARTMENT	AMOUNT
	7/03/24	SRVCS 5/21-6/20	GENERAL FUND	Zoning/Compliance/Perm	29.21
	7/03/24	SRVCS 5/21-6/20	ROAD USE TAX	Road Use Tax	116.84
	7/03/24	SRVCS 5/21-6/20	WATER UTILITY	Water	79.79
	7/03/24	SRVCS 5/21-6/20	SEWER UTILITY FUND	Sewer	101.16
				TOTAL:	502.26
TJ Concrete	6/27/24	CONCRETE PROJECT @ FD	GENERAL FUND	Fire Department	3,438.40
				TOTAL:	3,438.40
Temporary Vendo	6/27/24	W.W. VAN BUREN:	GENERAL FUND	Cemetery	500.00
AMY WAECHTER	6/27/24	REIMBURSE SWIM LESSONS	GENERAL FUND	Pool	60.00
AUBREY DUNBAR	6/28/24	AUBREY DUNBAR:	NILE KINNICK ADDIT	INVALID DEPARTMENT	373.89
				TOTAL:	933.89
Terie Barnett	7/03/24	CEMETERY PLOT BUY BACK	GENERAL FUND	Cemetery	300.00
				TOTAL:	300.00
Tiger Tire	6/27/24	TIRE REPAIR	GENERAL FUND	Cemetery	10.50
				TOTAL:	10.50
Treasurer State of Iowa - Sales Tax	6/20/24	Treasurer State of Iowa -	GENERAL FUND	Pool	2,692.79
	6/20/24	Treasurer State of Iowa -	WATER UTILITY	Water	8,825.42
	6/20/24	Treasurer State of Iowa -	SEWER UTILITY FUND	Sewer	1,412.45
				TOTAL:	12,930.66
Truck Equipment Inc	6/27/24	WESTERN SNOW PLOW	ROAD USE TAX	Road Use Tax	12,162.00
				TOTAL:	12,162.00
Tyler Kneip	6/25/24	UMPIRE GAME 6/10	GENERAL FUND	Recreation	45.00
				TOTAL:	45.00
Tyler Technologies, Inc.	6/30/24	June '24 Bank & CC Fees	GENERAL FUND	Finance	2,859.69
				TOTAL:	2,859.69
UULINE	6/27/24	STORAGE CABINETS	GENERAL FUND	Parks	3,354.54
				TOTAL:	3,354.54
UMB Bank, N.A.	6/25/24	Paying Agent Fee	DEBT SERVICE	Debt Service	250.00
				TOTAL:	250.00
US Cellular	6/27/24	WIFI HOT SPOT	GENERAL FUND	Library	269.61
				TOTAL:	269.61
USA Blue Book	6/27/24	TESTING & MISC SUPPLIES	WATER UTILITY	Water	769.32
	6/27/24	TESTING & MISC SUPPLIES	WATER UTILITY	Water	131.59
				TOTAL:	900.91
USDA Rural Development	6/30/24	USDA #3 Pmt (\$7,000,000)	WATER UTILITY	Water	12,077.02
	6/30/24	USDA #3 Pmt (\$7,000,000)	WATER UTILITY	Water	6,052.98
	6/30/24	USDA #3 Pmt (\$9,603,000)	WATER UTILITY	Water	16,118.43
	6/30/24	USDA #3 Pmt (\$9,603,000)	WATER UTILITY	Water	9,329.57
	6/30/24	USDA #6 (\$4,713,000)	WATER UTILITY	Water	7,578.13
	6/30/24	USDA #6 (\$4,713,000)	WATER UTILITY	Water	5,194.87
	6/30/24	USDA #4 Pmt	SEWER UTILITY FUND	Sewer	9,408.53
	6/30/24	USDA #4 Pmt	SEWER UTILITY FUND	Sewer	8,110.47
	6/30/24	USDA #1 Pmt	SEWER UTILITY FUND	Sewer	1,796.61

VENDOR NAME	DATE	DESCRIPTION	FUND	DEPARTMENT	AMOUNT
	6/30/24	USDA #1 Pmt	SEWER UTILITY FUND	Sewer	1,727.39
	6/30/24	USDA #5 Pmt (\$785,000)	SEWER UTILITY FUND	Sewer	1,327.59
	6/30/24	USDA #5 Pmt (\$785,000)	SEWER UTILITY FUND	Sewer	706.41
	6/30/24	USDA #5 Pmt (\$1,000,000)	SEWER UTILITY FUND	Sewer	1,576.57
	6/30/24	USDA #5 Pmt (\$1,000,000)	SEWER UTILITY FUND	Sewer	1,203.43
	6/30/24	USDA #5 Pmt (\$9,880,000)	SEWER UTILITY FUND	Sewer	15,577.09
	6/30/24	USDA #5 Pmt (\$9,880,000)	SEWER UTILITY FUND	Sewer	11,889.91
	6/30/24	USDA #2 Pmt	STORM WATER UTILIT	STORM WATER UTILITY	2,484.93
	6/30/24	USDA #2 Pmt	STORM WATER UTILIT	STORM WATER UTILITY	2,470.07
				TOTAL:	114,630.00
Umpire 1	6/17/24	BASEBALL UMPIRE 6/17/2024	GENERAL FUND	Recreation	65.00
	6/17/24	BASEBALL UMPIRE GAME 6/17/	GENERAL FUND	Recreation	65.00
	6/17/24	UMPIRE BASEBALL 6/18/2024	GENERAL FUND	Recreation	65.00
	6/25/24	JAMES CORNELIUS:	GENERAL FUND	Recreation	85.00
				TOTAL:	280.00
Verizon Wireless	6/27/24	GATEWAY COLLECTOR 5/16-6/1	WATER UTILITY	Water	40.01
	6/27/24	GATEWAY COLLECTOR 5/16-6/1	SEWER UTILITY FUND	Sewer	40.01
				TOTAL:	80.02
Vestis	6/27/24	MAY 2024 RENTAL	GENERAL FUND	Parks	28.14
	6/27/24	MAY 2024 RENTAL	GENERAL FUND	Finance	45.04
	6/27/24	MAY 2024 RENTAL	ROAD USE TAX	Road Use Tax	28.14
	6/27/24	MAY 2024 RENTAL	WATER UTILITY	Water	28.14
	6/27/24	MAY 2024 RENTAL	SEWER UTILITY FUND	Sewer	28.14
				TOTAL:	157.60
Visa	6/28/24	MICROSOFT SRVS	GENERAL FUND	Police Department	322.00
	6/28/24	VERIZON- CELL SRVS	GENERAL FUND	Police Department	508.64
	6/28/24	RANGEMASTER- SMITH & WESS	GENERAL FUND	Police Department	799.99
	6/28/24	WIRETAP- PHONE SRVS	GENERAL FUND	Police Department	43.47
	6/28/24	MICROSOFT SRVS	GENERAL FUND	Fire Department	6.00
	6/28/24	AMAZON- MAGNETIC MIC	GENERAL FUND	Fire Department	192.40
	6/28/24	MICROSOFT SRVS	GENERAL FUND	Library	145.01
	6/28/24	SCHEDULEBASE	GENERAL FUND	Library	10.00
	6/28/24	COLIBRI- BOOK COVER	GENERAL FUND	Library	410.89
	6/28/24	ULINE- STEEL DOLLY	GENERAL FUND	Parks	291.05
	6/28/24	BUSINESS FURN WAREHOUSE-	GENERAL FUND	Parks	199.00
	6/28/24	PART TREE- WEDEATER	GENERAL FUND	Parks	121.95
	6/28/24	SAFELIGHT-WINSHEILD	GENERAL FUND	Parks	190.44
	6/28/24	MICROSOFT SRVS	GENERAL FUND	Parks	18.00
	6/28/24	USPA- ENVELOPES	GENERAL FUND	Parks	104.69
	6/28/24	USPA- ENVELOPES	GENERAL FUND	Parks	104.70
	6/28/24	GRAINR- BALL VALVE	GENERAL FUND	Pool	84.98
	6/28/24	SWIMOUTLET-	GENERAL FUND	Pool	53.29
	6/28/24	WATERSAFETY- CPR MASK	GENERAL FUND	Pool	139.25
	6/28/24	POOL SUPPLY- POOL NET	GENERAL FUND	Pool	39.00
	6/28/24	BEST BUY- MOUSE	GENERAL FUND	Pool	18.18
	6/28/24	LOWES- CREDIT	GENERAL FUND	Pool	69.53
	6/28/24	AMAZON- CLOCK	GENERAL FUND	Pool	45.93
	6/28/24	SAMS CLUB- CONCESSION SUPP	GENERAL FUND	Pool	243.51
	6/28/24	DALLAS CO DATA	GENERAL FUND	Pool	99.00
	6/28/24	DALLAS CO DATA	GENERAL FUND	Pool	200.00
	6/28/24	SAMS CLUB- CONCESSION	GENERAL FUND	Recreation	1,056.51
	6/28/24	SAMS CLUB- CONCESSION	GENERAL FUND	Recreation	107.96

VENDOR NAME	DATE	DESCRIPTION	FUND	DEPARTMENT	AMOUNT_
	6/28/24	AMAZON- CONCESSION SUPPLIE	GENERAL FUND	Recreation	86.86
	6/28/24	EPIC SPORTS- SOFTBALL	GENERAL FUND	Recreation	185.96
	6/28/24	MICROSOFT SRVS	GENERAL FUND	Recreation	33.81
	6/28/24	SAM CLUB- POWERWHEELS	GENERAL FUND	Recreation	6,800.79
	6/28/24	USPA- ENVELOPES	GENERAL FUND	Recreation	104.69
	6/28/24	BW SUPPLIY BRICK CHIPS	GENERAL FUND	Finance	219.80
	6/28/24	MICROSOFT SRVS	GENERAL FUND	Finance	158.10
	6/28/24	DES MOINES REG DIGITAL COP	GENERAL FUND	Finance	16.04
	6/28/24	2024 IA LEAGUE CONF	GENERAL FUND	Finance	735.00
	6/28/24	IACMA DUES	GENERAL FUND	Finance	150.00
	6/28/24	WIRETAPE PHONE	GENERAL FUND	Finance	131.86
	6/28/24	FAMILY DOLLAR- POSTER BOAR	GENERAL FUND	Finance	4.28
	6/28/24	IA LEAGUE - MAYOR DUES	GENERAL FUND	Finance	30.00
	6/28/24	PRESERVE IA SUMMIT	GENERAL FUND	Finance	410.00
	6/28/24	BACKGROUND CHECK	GENERAL FUND	Finance	45.00
	6/28/24	ADOBE- RENEWAL	GENERAL FUND	Finance	1,144.04
	6/28/24	MPA CONF	GENERAL FUND	Finance	200.00
	6/28/24	DALLAS CO DATA	GENERAL FUND	Finance	577.00
	6/28/24	MICROSOFT SRVS	GENERAL FUND	Zoning/Compliance/Perm	23.00
	6/28/24	USPA- ENVELOPES	GENERAL FUND	Zoning/Compliance/Perm	104.70
	6/28/24	MICROSOFT SRVS	ROAD USE TAX	Road Use Tax	35.00
	6/28/24	USPA- ENVELOPES	ROAD USE TAX	Road Use Tax	104.69
	6/28/24	APPLE- IPAD	FIRE TRUCKS	Fire Trucks	1,299.00
	6/28/24	BEST BUY- IPAD CASE	FIRE TRUCKS	Fire Trucks	192.49
	6/28/24	SP RAM- IPAD MOUNTS	FIRE TRUCKS	Fire Trucks	377.26
	6/28/24	AWWA- MEMEBERSHIP	WATER UTILITY	Water	430.00
	6/28/24	IA DNR FEE	WATER UTILITY	Water	32.29
	6/28/24	VAN METER- CLAMP	WATER UTILITY	Water	170.00
	6/28/24	MICROSOFT SRVS	WATER UTILITY	Water	52.00
	6/28/24	USPA- ENVELOPES	WATER UTILITY	Water	104.69
	6/28/24	SIP-ALARM	SEWER UTILITY FUND	Sewer	32.03
	6/28/24	VAN METER- CLAMP	SEWER UTILITY FUND	Sewer	237.18
	6/28/24	MICROSOFT SRVS	SEWER UTILITY FUND	Sewer	35.00
	6/28/24	AMAZON- C FREEMEYER CLOTHI	SEWER UTILITY FUND	Sewer	222.85
	6/28/24	USPA- ENVELOPES	SEWER UTILITY FUND	Sewer	104.69
	6/28/24	USPA- ENVELOPES	SEWER UTILITY FUND	Sewer	104.70
	6/28/24	DALLAS CO DATA	SEWER UTILITY FUND	Sewer	109.99
	6/28/24	QUEEN BEE- FACE PAINTER	FRIENDS/FOUNDATION	Library	300.00
	6/28/24	ICONIC APPAREL- TSHIRT	FRIENDS/FOUNDATION	Library	125.00_
				TOTAL:	20,716.10
Waste Solutions of IA	6/27/24	PORT A POT	GENERAL FUND	Pool	146.00_
				TOTAL:	146.00
Waukee Power Equipment	6/27/24	WEEDEATER & CARB ADJ	GENERAL FUND	Parks	65.49
	6/27/24	BACKPACK BLOWER, WDEATR ST	GENERAL FUND	Cemetery	1,082.21
	6/27/24	TUBE FOR CHAIN SAW	ROAD USE TAX	Road Use Tax	20.11_
				TOTAL:	1,167.81
Webspec Design	7/03/24	JULY WEBHOSTING	GENERAL FUND	Finance	71.67
	7/03/24	JULY WEBHOSTING	WATER UTILITY	Water	71.66
	7/03/24	JULY WEBHOSTING	SEWER UTILITY FUND	Sewer	71.67_
				TOTAL:	215.00
Wellmark/BCBS of Iowa	6/20/24	PY-INSURANCE PREMIUM BCBS	GENERAL FUND	NON-DEPARTMENTAL	2,641.77
	6/20/24	PY-INSURANCE PREMIUM BCBS	ROAD USE TAX	NON-DEPARTMENTAL	387.23

VENDOR NAME	DATE	DESCRIPTION	FUND	DEPARTMENT	AMOUNT_
	6/27/24	JULY 24 PREMIUMS	ROAD USE TAX	Road Use Tax	4,099.18
	6/27/24	JULY 24 PREMIUMS	TRUST AND AGENCY	General Government	23,477.10
	6/20/24	PY-INSURANCE PREMIUM BCBS	WATER UTILITY	NON-DEPARTMENTAL	432.56
	6/27/24	JULY 24 PREMIUMS	WATER UTILITY	Water	4,471.83
	6/20/24	PY-INSURANCE PREMIUM BCBS	SEWER UTILITY FUND	NON-DEPARTMENTAL	500.39
	6/27/24	JULY 24 PREMIUMS	SEWER UTILITY FUND	Sewer	4,844.48
	6/20/24	PY-INSURANCE PREMIUM BCBS	STORM WATER UTILIT	NON-DEPARTMENTAL	43.91
	6/27/24	JULY 24 PREMIUMS	STORM WATER UTILIT	STORM WATER UTILITY	372.65_
				TOTAL:	41,271.10
Wex Bank	7/03/24	JUN 2024 FUEL	GENERAL FUND	Police Department	1,212.70
	7/03/24	JUN 2024 FUEL	GENERAL FUND	Fire Department	23.51
	7/03/24	JUN 2024 FUEL	GENERAL FUND	Parks	423.38_
				TOTAL:	1,659.59
Wilcox Printing and Publishing, Inc.	6/27/24	PO BOOK	GENERAL FUND	Police Department	37.59
	6/27/24	PO BOOK	GENERAL FUND	Fire Department	37.59
	6/27/24	PO BOOK	GENERAL FUND	Parks	37.59
	6/27/24	PO BOOK	GENERAL FUND	Pool	37.59
	6/27/24	PO BOOK	GENERAL FUND	Recreation	37.59
	6/27/24	PO BOOK	WATER UTILITY	Water	37.60
	6/27/24	PO BOOK	WATER UTILITY	Water	37.60
	6/27/24	PO BOOK	SEWER UTILITY FUND	Sewer	37.60
	6/27/24	PO BOOK	STORM WATER UTILIT	STORM WATER UTILITY	37.60_
				TOTAL:	338.35
**PAYROLL EXPENSES	6/13/2024 - 7/03/2024		GENERAL FUND	Police Department	33,724.81
			GENERAL FUND	Library	11,133.51
			GENERAL FUND	Parks	7,626.16
			GENERAL FUND	Cemetery	2,277.21
			GENERAL FUND	Pool	30,396.90
			GENERAL FUND	Recreation	6,413.98
			GENERAL FUND	Finance	3,104.25
			GENERAL FUND	Zoning/Compliance/Perm	1,919.62
			ROAD USE TAX	Road Use Tax	9,750.82
			WATER UTILITY	Water	14,479.87
			SEWER UTILITY FUND	Sewer	15,439.72
			STORM WATER UTILIT	STORM WATER UTILITY	976.39_
				TOTAL:	137,243.24

VENDOR NAME	DATE	DESCRIPTION	FUND	DEPARTMENT	AMOUNT_
===== FUND TOTALS =====					
001		GENERAL FUND			332,914.51
110		ROAD USE TAX			42,612.77
112		TRUST AND AGENCY			44,775.98
200		DEBT SERVICE			250.00
328		FIRE TRUCKS			1,868.75
333		NEW WASTEWTR TRTMNT PLNT			15,870.00
338		WATER UTIL IMPROV P2			6,968.41
342		N 15TH ST BRIDGE REPLACE			12,222.07
343		CIRTPA TRAILS			60,774.05
346		CHANNEL STABILIZATION			1,760.70
600		WATER UTILITY			187,696.36
610		SEWER UTILITY FUND			120,876.21
615		STORM WATER UTILITY			9,741.04
951		FRIENDS/FOUNDATION			665.00
956		NILE KINNICK ADDITION			373.89
-----			GRAND TOTAL:		839,369.74
-----					

TOTAL PAGES: 14

SELECTION CRITERIA

-----  
SELECTION OPTIONS

VENDOR SET: 01-ADEL  
VENDOR: All  
CLASSIFICATION: All  
BANK CODE: All  
ITEM DATE: 6/13/2024 THRU 7/03/2024  
ITEM AMOUNT: 99,999,999.00CR THRU 99,999,999.00  
GL POST DATE: 0/00/0000 THRU 99/99/9999  
CHECK DATE: 0/00/0000 THRU 99/99/9999

-----  
PAYROLL SELECTION

PAYROLL EXPENSES: YES  
EXPENSE TYPE: GROSS  
CHECK DATE: 6/13/2024 THRU 7/03/2024

-----  
PRINT OPTIONS

PRINT DATE: Item Date  
SEQUENCE: By Vendor Name  
DESCRIPTION: Distribution  
GL ACCTS: NO  
REPORT TITLE: C O U N C I L R E P O R T  
SIGNATURE LINES: 0

-----  
PACKET OPTIONS

INCLUDE REFUNDS: YES  
INCLUDE OPEN ITEM: YES  
-----

	BALANCE 7-1-23	RECEIPTS	TRANSFERS IN	DISBURSEMENTS	TRANSFERS OUT	ACCOUNTS PAYABLE	BALANCE 6-30-24
<b>General Funds</b>							
General	2,346,853.31	3,899,421.82	956,589.49	3,430,051.68	88,775.85	-	3,684,037.09
SPEC RESERVE	452,003.81	188.56	34,700.00	-	40,000.00	-	446,892.37
Emergency Levy	17,283.07	59,655.59	-	-	58,090.53	-	18,848.13
Police Academy	8,625.17	-	-	-	8,625.00	-	0.17
Police cops fast	10.00	-	-	-	-	-	10.00
Fire	9,897.37	1,503.00	-	-	10,178.00	-	1,222.37
Refunds	28,307.08	-	-	-	-	-	28,307.08
CP - Fire Equipment Upgrade	0.00	-	-	-	-	-	0.00
CP - Industrial Park	118,469.31	-	-	-	-	-	118,469.31
Donations -Rec	6,890.86	1,315.00	-	7,626.40	-	-	579.46
Hotel-Motel Tax	43,895.80	8,487.36	-	-	-	-	52,383.16
Oakdale Pride	113.45	-	-	-	-	-	113.45
Friends/Foundation	337.14	10,225.98	-	7,129.76	-	-	3,433.36
Historic Pres Plaques	10.55	-	-	-	-	-	10.55
Holiday Lights	0.00	-	-	-	-	-	0.00
Nile Kinnick Addition	16,397.57	7,556.75	-	11,386.23	-	-	12,568.09
<b>Total</b>	<b>3,049,094.49</b>	<b>3,988,354.06</b>	<b>991,289.49</b>	<b>3,456,194.07</b>	<b>205,669.38</b>	<b>-</b>	<b>4,366,874.59</b>
<b>Special Revenue Funds</b>							
Road Use Tax	554,402.84	869,127.23	-	693,664.70	359,323.00	-	370,542.37
Urban Renewal Tax Increment	24,421.36	491,706.46	-	-	492,544.00	-	23,583.82
Employee Benefits/HRA	439,173.79	808,852.40	16,687.00	720,367.29	1,272.46	-	543,073.44
LOST FUNDS	1,752,161.58	1,824,467.67	72,088.85	-	842,152.00	-	2,806,566.10
Library Memorial	7,171.55	9,591.56	-	-	10,774.92	-	5,988.19
Police DARE	2,853.77	272.25	-	-	562.00	-	2,564.02
POLICE FORFEITURE FUND	3,397.27	-	-	-	818.40	-	2,578.87
<b>Total</b>	<b>2,783,582.16</b>	<b>4,004,017.57</b>	<b>88,775.85</b>	<b>1,426,187.31</b>	<b>1,695,291.46</b>	<b>-</b>	<b>3,754,896.61</b>
<b>Capital Project Funds</b>							
CP - Brownfield Project	2,359.33	-	-	-	-	-	2,359.33
CP - 2008 Flood Repair	2,949.18	-	-	-	-	-	2,949.18
CP - 2010 St Project	2,691.86	-	-	-	-	-	2,691.86
CP - Sidewalk Project	(16,043.00)	-	-	-	-	-	(16,043.00)
CP - 2006 Street Improvement	(10,483.83)	-	-	-	-	-	(10,483.83)
DS - 2002 Street	28,424.00	-	-	-	-	-	28,424.00
2010 Brick St Spec Assess	18,189.73	-	-	-	-	-	18,189.73
2017 Brick St Spec Assess	138,550.69	6,145.00	-	-	15,336.00	-	129,359.69
Adel Hwy 169 Improv	(44,812.67)	-	-	-	-	-	(44,812.67)
2019 Flood	76,231.40	-	-	-	-	-	76,231.40
2020 Derecho	10,798.38	-	-	-	-	-	10,798.38
Eagle Vista Dr Rehab	-	-	-	-	-	-	-
Fire Trucks	717,810.66	-	-	739,965.10	-	-	(22,154.44)
N 15th St Bridge Replacement	(69,455.78)	-	359,323.00	112,447.77	-	-	177,419.45
CIRTPA Trails	758,891.00	-	-	142,645.41	-	-	616,245.59
2022 St Resurfacing	(35,300.00)	-	-	-	-	-	(35,300.00)
Rapids St Reconstruction	(36,000.00)	-	-	-	-	-	(36,000.00)
<b>Total</b>	<b>1,544,800.95</b>	<b>6,145.00</b>	<b>359,323.00</b>	<b>995,058.28</b>	<b>15,336.00</b>	<b>-</b>	<b>899,874.67</b>
<b>Debt Service Fund</b>							
Debt Service-Property Tax	170,948.84	480,367.26	497,880.00	831,555.00	-	-	317,641.10
	170,948.84	480,367.26	497,880.00	831,555.00	-	-	317,641.10
<b>Internal Service Funds</b>							
Flex Plan	4,367.27	9,824.52	-	9,371.98	-	-	4,819.81
	4,367.27	9,824.52	-	9,371.98	-	-	4,819.81
<b>Enterprise Funds</b>							
Water	699,662.07	1,254,773.04	-	1,157,795.08	-	-	796,640.03
Sinking Fund	56,351.00	676,212.00	-	676,212.00	-	-	56,351.00
USDA #3 Bond Reserve (\$7,000,000)	65,268.00	21,756.00	-	-	-	-	87,024.00
USDA #3 Bond Reserve (\$9,603,000)	91,620.00	30,540.00	-	-	-	-	122,160.00
USDA #3 Short Lived Asset Reserve (\$32,740,000)	98,220.24	32,740.08	-	-	-	-	130,960.32
USDA #6 Bond Reserve	30,672.00	15,336.00	-	-	-	-	46,008.00
USDA #6 Short Lived Asset Reserve (\$14,737,000)	29,474.08	14,737.08	-	-	-	-	44,211.16
Improvement	2,483,656.81	52,305.30	-	-	-	-	2,535,962.11
CWI	(0.00)	-	-	-	-	-	(0.00)
Water Deposits	211,151.22	36,034.75	-	20,745.00	-	-	226,440.97
CP - Water Utility Improvements - Phase 2	(4,351.25)	213,017.10	-	216,330.16	-	-	(7,664.31)
Sewer	847,314.37	988,605.96	-	1,068,314.29	7,299.38	-	760,306.66
Sinking Fund	53,324.00	639,888.00	-	639,888.00	-	-	53,324.00
USDA #1 Bond Reserve	22,945.00	4,236.00	-	-	-	-	27,181.00
USDA #1 Short Lived Asset Reserve (\$10,000,000)	60,000.40	10,000.08	-	-	-	-	70,000.48
USDA #4 Bond Reserve	73,584.00	21,024.00	-	-	-	-	94,608.00
USDA #4 Short Lived Asset Reserve (Add'l \$6,000,000)	24,000.00	6,000.00	-	-	-	-	30,000.00
USDA #5 Bond Reserve	77,496.00	38,748.00	-	-	-	-	116,244.00
USDA #5 Short Lived Asset Reserve (Add'l \$4,030,000)	24,060.08	4,030.08	-	-	-	-	28,090.16
Improvement	1,861,702.45	171,183.65	-	-	-	-	2,032,886.10
CSI	(0.00)	-	-	-	-	-	(0.00)
E. Annex Sewer Connection Fees	271,471.75	-	-	-	-	-	271,471.75
CP - New Wastewater Treatment Plant	(1,080.00)	508,667.85	-	542,761.74	-	-	(35,173.89)
CP - Southbridge Lift Station	(4,747.71)	701.21	1,327.88	98,733.69	-	-	(101,452.31)
Storm Water	559,287.32	158,700.45	-	93,640.81	114,000.00	-	510,346.96
USDA #2 Bond Reserve	27,280.00	5,952.00	-	-	-	-	33,232.00
USDA #2 Short Lived Asset Reserve	7,500.00	1,500.00	-	-	-	-	9,000.00
CSWI	395,877.36	175,447.41	-	118,920.00	-	-	452,404.77
Channel Stabilization	-	-	114,000.00	21,380.00	-	-	92,620.00
Garbage / Recycling	60,739.15	489,347.22	-	468,380.94	15,000.00	-	66,705.43
	8,122,478.34	5,571,483.26	115,327.88	5,123,101.71	136,299.38	-	8,549,888.39
<b>Total</b>	<b>15,675,272.05</b>	<b>14,060,191.67</b>	<b>2,052,596.22</b>	<b>11,841,468.35</b>	<b>2,052,596.22</b>	<b>-</b>	<b>17,893,995.37</b>
<b>CASH</b>							
Certificate of Deposit - RVB	106,403.43	-	-	-	-	-	106,403.43
Peoples Bank Balance	17,261,945.80	-	-	-	-	-	17,261,945.80
Peoples Bank - Merchant Account	-	-	-	-	-	-	-
Peoples Bank - Storm Water Project	-	-	-	-	-	-	-
Peoples Bank - Water Util Improv	165,330.06	-	-	-	-	-	165,330.06
Peoples Bank - East Sewer Ext	-	-	-	-	-	-	-
Peoples Bank - WWTP	-	-	-	-	-	-	-
IPAIT	855,037.20	-	-	-	-	-	855,037.20
<b>Total CIB</b>	<b>18,388,716.49</b>	<b>Outstanding (494,721.12)</b>	<b>Total</b>	<b>17,893,995.37</b>	<b>-</b>	<b>-</b>	<b>-</b>

	BALANCE 6-1-24	RECEIPTS	TRANSFERS IN	DISBURSEMENTS	TRANSFERS OUT	ACCOUNTS PAYABLE	BALANCE 6-30-24
<b>General Funds</b>							
General	3,865,700.56	241,233.65	1,861.00	424,758.12			3,684,037.09
SPEC RESERVE	446,876.47	15.90					446,892.37
Emergency Levy	18,299.31	548.82					18,848.13
Police Academy	0.17						0.17
Police cops fast	10.00						10.00
Fire	3,083.37				1,861.00		1,222.37
Refunds	28,307.08						28,307.08
CP - Fire Equipment Upgrade	0.00						0.00
CP - Industrial Park	118,469.31						118,469.31
Donations - Rec	419.46	160.00					579.46
Hotel-Motel Tax	52,383.16						52,383.16
Oakdale Pride	113.45						113.45
Friends/Foundation	3,830.52	331.30		728.46			3,433.36
Historic Pres Plaques	10.55						10.55
Holiday Lights	0.00						0.00
Nile Kinnick Addition	15,941.98			3,373.89			12,568.09
Total	4,553,445.39	242,289.67	1,861.00	428,860.47	1,861.00	-	4,366,874.59
<b>Special Revenue Funds</b>							
Road Use Tax	655,934.35	98,104.67		55,173.65	328,323.00		370,542.37
Urban Renewal Tax Increment	17,041.33	6,542.49					23,583.82
Employee Benefits/HRA	592,029.93	7,430.86		56,387.35			543,073.44
LOST FUNDS	2,692,799.62	113,766.48					2,806,566.10
Library Memorial	5,498.19	490.00					5,988.19
Police DARE	2,564.02						2,564.02
POLICE FORFEITURE FUND	2,578.87						2,578.87
Total	3,968,446.31	226,334.50	-	111,561.00	328,323.00	-	3,754,896.81
<b>Capital Project Funds</b>							
CP - Brownfield Project	2,359.33						2,359.33
CP - 2008 Flood Repair	2,949.18						2,949.18
CP - 2010 St Project	2,691.86						2,691.86
CP - Sidewalk Project	(16,043.00)						(16,043.00)
CP - 2006 Street Improvement	(10,483.83)						(10,483.83)
DS - 2002 Street	28,424.00						28,424.00
2010 Brick St Spec Assess	18,189.73						18,189.73
2017 Brick St Spec Assess	129,359.69						129,359.69
Adel Hwy 169 Improv	(44,812.67)						(44,812.67)
2019 Flood	76,231.40						76,231.40
2020 Derecho	10,798.38						10,798.38
Eagle Vista Dr Rehab	-						-
Fire Trucks	(17,520.69)			4,633.75			(22,154.44)
N 15th St Bridge Replacement	(147,035.75)		328,323.00	3,867.80			177,419.45
CIRTPA Trails	632,569.14			16,323.55			616,245.59
2022 St Resurfacing	(35,300.00)						(35,300.00)
Rapids St Reconstruction	(36,000.00)						(36,000.00)
Total	596,376.77	-	328,323.00	24,825.10	-	-	899,874.67
<b>Debt Service Fund</b>							
Debt Service-Property Tax	313,325.99	4,565.11		250.00			317,641.10
	313,325.99	4,565.11	-	250.00		-	317,641.10
<b>Internal Service Funds</b>							
Flex Plan	4,525.81	789.00		495.00			4,819.81
	4,525.81	789.00	-	495.00		-	4,819.81
<b>Enterprise Funds</b>							
Water	902,877.40	104,564.42		210,801.79			796,640.03
Sinking Fund	56,351.00	56,351.00		56,351.00			56,351.00
USDA #3 Bond Reserve (\$7,000,000)	85,211.00	1,813.00					87,024.00
USDA #3 Bond Reserve (\$9,603,000)	119,615.00	2,545.00					122,160.00
USDA #3 Short Lived Asset Reserve (\$32,740 Pe	128,231.98	2,728.34					130,960.32
USDA #6 Bond Reserve	44,730.00	1,278.00					46,008.00
USDA #6 Short Lived Asset Reserve (\$14,737 Pe	42,983.07	1,228.09					44,211.16
Improvement	2,560,213.24	(24,251.13)					2,535,962.11
CWI	(0.00)						(0.00)
Water Deposits	225,559.42	3,306.55		2,425.00			226,440.97
CP - Water Utility Improvements - Phase 2	(6,251.31)			1,413.00			(7,664.31)
Sewer	767,009.98	82,383.83		89,087.15			760,306.66
Sinking Fund	53,324.00	53,324.00		53,324.00			53,324.00
USDA #1 Bond Reserve	26,828.00	353.00					27,181.00
USDA #1 Short Lived Asset Reserve (\$10,000 Pe	69,167.14	833.34					70,000.48
USDA #4 Bond Reserve	92,856.00	1,752.00					94,608.00
USDA #4 Short Lived Asset Reserve (Add'l \$6,00	29,500.00	500.00					30,000.00
USDA #5 Bond Reserve	113,015.00	3,229.00					116,244.00
USDA #5 Short Lived Asset Reserve (Add'l \$4,03	27,754.32	335.84					28,090.16
Improvement	2,037,498.69	(4,612.59)					2,032,886.10
CSI	(0.00)						(0.00)
E. Annex Sewer Connection Fees	271,471.75						271,471.75
CP - New Wastewater Treatment Plant	(17,508.89)			17,665.00			(35,173.89)
CP - Southbridge Lift Station	(101,452.31)						(101,452.31)
Storm Water	616,492.12	12,983.19		5,128.35	114,000.00		510,346.96
USDA #2 Bond Reserve	32,736.00	496.00					33,232.00
USDA #2 Short Lived Asset Reserve	8,875.00	125.00					9,000.00
CSWI	502,502.21	14,317.56		64,415.00			452,404.77
Channel Stabilization	(21,380.00)		114,000.00				92,620.00
Garbage / Recycling	66,811.95	39,314.00		39,420.52			66,705.43
	8,735,021.76	354,897.44	114,000.00	540,030.81	114,000.00	-	8,549,888.39
Total	18,171,142.03	828,675.72	444,184.00	1,106,022.38	444,184.00	-	17,893,995.37
<b>CASH</b>							
Certificate of Deposit - RVB	106,403.43						106,403.43
Peoples Bank Balance	17,261,945.80						17,261,945.80
Peoples Bank - Merchant Account	-						-
Peoples Bank - Storm Water Project	-						-
Peoples Bank - Water Util Improv	165,330.06						165,330.06
Peoples Bank - East Sewer Ext	-						-
Peoples Bank - WWTP	-						-
IPAIT	855,037.20						855,037.20
Total CIB	18,388,716.49	Outstanding (494,721.12)		Total 17,893,995.37			

CITY OF ADEL  
 MONTH TO DATE TREASURERS REPORT  
 AS OF: JUNE 30TH, 2024

FUND	BEGINNING CASH BALANCE	MTD REVENUES	MTD EXPENSES	ACCOUNTS PAYABLE	ENDING CASH BALANCE	TOTAL INVESTMENTS	TOTAL CASH & INVESTMENTS
GENERAL FUND	3,865,700.56	243,094.65	424,758.12	0.00	3,684,037.09	0.00	3,684,037.09
SPECIAL RESERVE TRANSFER	446,876.47	15.90	0.00	0.00	446,892.37	0.00	446,892.37
ROAD USE TAX	655,934.35	98,104.67	383,496.65	0.00	370,542.37	0.00	370,542.37
TRUST AND AGENCY	882,875.63	12,725.23	61,168.35	0.00	834,432.51	0.00	834,432.51
HOTEL-MOTEL TAX	52,383.16	0.00	0.00	0.00	52,383.16	0.00	52,383.16
TIF	17,041.33	6,542.49	0.00	0.00	23,583.82	0.00	23,583.82
2010 BRICK ST SPEC ASSES	18,189.73	0.00	0.00	0.00	18,189.73	0.00	18,189.73
2002 ST/UTIL-SPEC ASSESS	28,424.00	0.00	0.00	0.00	28,424.00	0.00	28,424.00
2017 BRICK ST SPEC ASSESS	129,359.69	0.00	0.00	0.00	129,359.69	0.00	129,359.69
DEBT SERVICE	313,325.99	4,565.11	250.00	0.00	317,641.10	0.00	317,641.10
2006 STREET IMP PROJECT	( 10,483.83)	0.00	0.00	0.00	( 10,483.83)	0.00	( 10,483.83)
BROWNFIELD PROJECT	2,359.33	0.00	0.00	0.00	2,359.33	0.00	2,359.33
2008 FLOOD REPAIR PROJEC	2,949.18	0.00	0.00	0.00	2,949.18	0.00	2,949.18
2010 STREET PROJECT	2,691.86	0.00	0.00	0.00	2,691.86	0.00	2,691.86
SIDEWALK PROJECT	( 16,043.00)	0.00	0.00	0.00	( 16,043.00)	0.00	( 16,043.00)
INDUSTRIAL PARK PROJECT	118,469.31	0.00	0.00	0.00	118,469.31	0.00	118,469.31
LOST FUNDS - AQUATIC CEN	2,692,799.62	113,766.48	0.00	0.00	2,806,566.10	0.00	2,806,566.10
FIRE TRUCKS	( 17,520.69)	0.00	4,633.75	0.00	( 22,154.44)	0.00	( 22,154.44)
NEW WASTEWTR TRTMT PLNT	( 17,508.89)	0.00	17,665.00	0.00	( 35,173.89)	0.00	( 35,173.89)
ADEL HWY 169 IMPROV	( 44,812.67)	0.00	0.00	0.00	( 44,812.67)	0.00	( 44,812.67)
2019 FLOOD	76,231.40	0.00	0.00	0.00	76,231.40	0.00	76,231.40
WATER UTIL IMPROV P2	( 6,251.31)	0.00	1,413.00	0.00	( 7,664.31)	0.00	( 7,664.31)
SOUTHBRIDGE LIFT STATION	( 101,452.31)	0.00	0.00	0.00	( 101,452.31)	0.00	( 101,452.31)
2020 Derecho	10,798.38	0.00	0.00	0.00	10,798.38	0.00	10,798.38
N 15TH ST BRIDGE REPLACE	( 147,035.75)	328,323.00	3,867.80	0.00	177,419.45	0.00	177,419.45
CIRTPA TRAILS	632,569.14	0.00	16,323.55	0.00	616,245.59	0.00	616,245.59
2022 ST RESURFACING	( 35,300.00)	0.00	0.00	0.00	( 35,300.00)	0.00	( 35,300.00)
RAPIDS ST RECONSTRUCTION	( 36,000.00)	0.00	0.00	0.00	( 36,000.00)	0.00	( 36,000.00)
CHANNEL STABILIZATION	( 21,380.00)	114,000.00	0.00	0.00	92,620.00	0.00	92,620.00
WATER UTILITY	3,940,212.69	146,256.72	267,152.79	0.00	3,819,316.62	0.00	3,819,316.62
SEWER UTILITY FUND	3,488,424.88	138,098.42	142,411.15	0.00	3,484,112.15	0.00	3,484,112.15
STORM WATER UTILITY	1,160,605.33	27,921.75	183,543.35	0.00	1,004,983.73	0.00	1,004,983.73
GARBAGE/RECYCLING UTILITY	66,811.95	39,314.00	39,420.52	0.00	66,705.43	0.00	66,705.43
OAKDALE PRIDE	113.45	0.00	0.00	0.00	113.45	0.00	113.45
FRIENDS/FOUNDATION	3,830.52	331.30	728.46	0.00	3,433.36	0.00	3,433.36
HISTORIC PRES PLAQUES	10.55	0.00	0.00	0.00	10.55	0.00	10.55
NILE KINNICK ADDITION	15,941.98	0.00	3,373.89	0.00	12,568.09	0.00	12,568.09
GRAND TOTAL	18,171,142.03	1,273,059.72	1,550,206.38	0.00	17,893,995.37	0.00	17,893,995.37
	=====	=====	=====	=====	=====	=====	=====

\*\*\* END OF REPORT \*\*\*

CITY OF ADEL  
 STATEMENT OF REVENUES - BUDGET VS. ACTUAL  
 AS OF: JUNE 30TH, 2024

REVENUES	ORIGINAL BUDGET	CURRENT BUDGET	MONTHLY REVENUE	YEAR-TO-DATE REVENUE	PRIOR YEAR YEAR-TO-DATE	BUDGET REMAINING	% BUDGET REMAINING
001-GENERAL FUND	3,615,643	4,036,474	243,094.65	4,856,011.31	3,535,357.65 (	819,536.90)	20.30-
002-SPECIAL RESERVE TRANS	34,700	34,700	15.90	34,888.56	34,822.43 (	188.56)	0.54-
110-ROAD USE TAX	787,584	787,584	98,104.67	869,127.23	877,869.65 (	81,543.23)	10.35-
112-TRUST AND AGENCY	931,484	943,439	12,725.23	943,736.07	793,363.43 (	297.07)	0.03-
122-HOTEL-MOTEL TAX	0	0	0.00	8,487.36	11,506.70 (	8,487.36)	0.00
125-TIF	492,544	492,544	6,542.49	491,706.46	469,524.31	837.54	0.17
135-2017 BRICK ST SPEC AS	7,741	7,741	0.00	6,145.00	7,691.00	1,596.00	20.62
200-DEBT SERVICE	977,449	977,449	4,565.11	978,247.26	881,286.38 (	798.26)	0.08-
324-LOST FUNDS - AQUATIC	1,485,344	1,485,344	113,766.48	1,896,556.52	1,890,358.43 (	411,212.52)	27.68-
328-FIRE TRUCKS	0	0	0.00	0.00	407,823.83	0.00	0.00
333-NEW WASTEWTR TRTMNT P	360,000	538,000	0.00	508,667.85	1,015,642.83	29,332.15	5.45
338-WATER UTIL IMPROV P2	765,000	765,000	0.00	213,017.10	469,610.21	551,982.90	72.15
339-SOUTHBRIDGE LIFT STAT	0	702	0.00	2,029.09	475,000.00 (	1,327.09)	189.04-
341-EAGLE VISTA DR REHAB	0	0	0.00	0.00	6,384.29	0.00	0.00
342-N 15TH ST BRIDGE REPL	556,000	470,000	328,323.00	359,323.00	95,000.00	110,677.00	23.55
343-CIRTPA TRAILS	0	0	0.00	0.00	950,000.00	0.00	0.00
346-CHANNEL STABILIZATION	0	0	114,000.00	114,000.00	0.00 (	114,000.00)	0.00
600-WATER UTILITY	2,034,439	2,160,439	146,256.72	2,098,399.50	2,083,401.67	62,039.50	2.87
610-SEWER UTILITY FUND	1,691,651	1,877,251	138,098.42	1,883,715.77	1,884,850.22 (	6,464.77)	0.34-
615-STORM WATER UTILITY	329,370	329,370	27,921.75	341,599.86	368,036.03 (	12,229.86)	3.71-
670-GARBAGE/RECYCLING UTI	479,984	482,984	39,314.00	489,347.22	478,664.98 (	6,363.22)	1.32-
951-FRIENDS/FOUNDATION	7,000	9,174	331.30	10,225.98	11,380.32 (	1,051.98)	11.47-
955-HOLIDAY LIGHTS	0	0	0.00	0.00	500.00	0.00	0.00
956-NILE KINNICK ADDITION	0	0	0.00	7,556.75	1,524.87 (	7,556.75)	0.00
<b>TOTAL REVENUES</b>	<b>14,555,933</b>	<b>15,398,195</b>	<b>1,273,059.72</b>	<b>16,112,787.89</b>	<b>16,749,599.23 (</b>	<b>714,592.48)</b>	<b>4.64-</b>

CITY OF ADEL  
 STATEMENT OF EXPENDITURES - BUDGET vs ACTUAL  
 AS OF: JUNE 30TH, 2024

EXPENDITURES	ORIGINAL BUDGET	CURRENT BUDGET	MONTHLY EXPENDITURES	YEAR-TO-DATE EXP. + ENCUMB.	PRIOR YEAR YEAR-TO-DATE	BUDGET REMAINING	% BUDGET REMAINING
001-GENERAL FUND	3,617,525	3,908,186	424,758.12	3,518,827.53	3,174,275.47	389,358.47	9.96
002-SPECIAL RESERVE TRANS	40,000	40,000	0.00	40,000.00	20,000.00	0.00	0.00
110-ROAD USE TAX	820,103	1,148,426	383,496.65	1,052,987.70	799,254.52	95,438.30	8.31
112-TRUST AND AGENCY	911,135	943,461	61,168.35	848,431.98	680,719.49	95,029.02	10.07
125-TIF	492,544	492,544	0.00	492,544.00	492,544.00	0.00	0.00
135-2017 BRICK ST SPEC AS	15,336	15,336	0.00	15,336.00	15,571.00	0.00	0.00
200-DEBT SERVICE	831,555	831,555	250.00	831,555.00	833,205.00	0.00	0.00
324-LOST FUNDS - AQUATIC	842,152	842,152	0.00	842,152.00	1,664,536.00	0.00	0.00
328-FIRE TRUCKS	815,648	740,474	4,633.75	739,965.10	97,837.00	508.90	0.07
333-NEW WASTEWTR TRMNT P	360,000	538,000	17,665.00	542,761.74	1,016,476.92 (	4,761.74)	0.89-
338-WATER UTIL IMPROV P2	765,000	765,000	1,413.00	216,330.16	466,586.46	548,669.84	71.72
339-SOUTHBRIDGE LIFT STAT	0	99,000	0.00	98,733.69	703,046.63	266.31	0.27
341-EAGLE VISTA DR REHAB	0	0	0.00	0.00	6,384.29	0.00	0.00
342-N 15TH ST BRIDGE REPL	556,000	400,000	3,867.80	112,447.77	164,455.78	287,552.23	71.89
343-CIRTPA TRAILS	561,000	150,000	16,323.55	142,645.41	191,109.00	7,354.59	4.90
346-CHANNEL STABILIZATION	0	114,000	0.00	21,380.00	0.00	92,620.00	81.25
600-WATER UTILITY	1,930,985	1,969,200	267,152.79	1,834,007.08	1,671,943.86	135,192.92	6.87
610-SEWER UTILITY FUND	1,628,494	1,868,240	142,411.15	1,715,501.67	2,061,549.75	152,738.33	8.18
615-STORM WATER UTILITY	276,965	277,807	183,543.35	326,560.81	238,709.16 (	48,753.81)	17.55-
670-GARBAGE/RECYCLING UTI	475,112	483,212	39,420.52	483,380.94	467,667.21 (	168.94)	0.03-
951-FRIENDS/FOUNDATION	7,000	9,513	728.46	7,129.76	18,770.70	2,383.24	25.05
955-HOLIDAY LIGHTS	0	0	0.00	0.00	2,176.56	0.00	0.00
956-NILE KINNICK ADDITION	0	0	3,373.89	11,386.23	751.00 (	11,386.23)	0.00
<b>TOTAL EXPENDITURES</b>	<b>14,946,554</b>	<b>15,636,106</b>	<b>1,550,206.38</b>	<b>13,894,064.57</b>	<b>14,787,569.80</b>	<b>1,742,041.43</b>	<b>11.14</b>
	=====	=====	=====	=====	=====	=====	=====
REVENUE OVER/(UNDER) EXPENDITURES	( 390,621)	( 237,911)	( 277,146.66)	2,218,723.32	1,962,029.43	( 2,456,633.91)	6,468.49

001-GENERAL FUND

100.00% OF YEAR COMP.

REVENUES	CURRENT BUDGET	CURRENT PERIOD	YEAR TO DATE ACTUAL	% OF BUDGET	BUDGET BALANCE
<b>Non Departmental</b>					
=====					
<b>TAXES</b>					
001-4-000-4-4000 PROPERTY TAXES	1,702,709.00	16,322.36	1,697,281.28	99.68	5,427.72
001-4-000-4-4003 AG LAND - CORP ROAD	3,977.00	0.48	3,977.27	100.01 (	0.27)
001-4-000-4-4013 PROPERTY/LIABILITY INSURANCE	93,539.00	894.82	93,008.34	99.43	530.66
001-4-000-4-4060 UTILITY EXCISE TAX	0.00	0.00	9,972.90	0.00 (	9,972.90)
001-4-000-4-4080 MOBILE HOME TAX	<u>3,499.00</u>	<u>150.47</u>	<u>3,067.53</u>	<u>87.67</u>	<u>431.47</u>
TOTAL TAXES	1,803,724.00	17,368.13	1,807,307.32	100.20 (	3,583.32)
<b>LICENSES &amp; PERMITS</b>					
001-4-000-1-4100 BEER & LIQUOR PERMITS	5,000.00	0.00	5,113.45	102.27 (	113.45)
001-4-000-1-4105 CIGARETTE PERMITS	450.00	225.00	525.00	116.67 (	75.00)
001-4-000-1-4160 UTILITY FRANCHISE FEES	8,000.00	0.00	6,283.76	78.55	1,716.24
001-4-000-1-4170 PEDDLERS, SOLICITERS, TRANSIENT	1,000.00	650.00	1,950.00	195.00 (	950.00)
001-4-000-1-4175 SPECIAL EVENT PERMITS	300.00	0.00	225.00	75.00	75.00
001-4-000-1-4185 BICYCLE/GOLF CART PERMIT	<u>1,000.00</u>	<u>200.00</u>	<u>2,450.00</u>	<u>245.00 (</u>	<u>1,450.00)</u>
TOTAL LICENSES & PERMITS	15,750.00	1,075.00	16,547.21	105.06 (	797.21)
<b>USE OF MONEY &amp; PROPERTY</b>					
001-4-000-4-4300 INTEREST ON INVESTMENTS-N.O.W.	162,000.00	67,167.29	837,625.79	517.05 (	675,625.79)
001-4-000-4-4320 RENTALS	<u>75,000.00</u>	<u>13,153.72</u>	<u>98,141.79</u>	<u>130.86 (</u>	<u>23,141.79)</u>
TOTAL USE OF MONEY & PROPERTY	237,000.00	80,321.01	935,767.58	394.84 (	698,767.58)
<b>INTERGOVERNMENTAL</b>					
001-4-000-4-4463 BUSINESS PROP TAX REIM	0.00	0.00	59,576.34	0.00 (	59,576.34)
001-4-000-4-4464 COMM-IND PROP TAX BACKFILL	<u>81,415.00</u>	<u>0.00</u>	<u>24,888.21</u>	<u>30.57</u>	<u>56,526.79</u>
TOTAL INTERGOVERNMENTAL	81,415.00	0.00	84,464.55	103.75 (	3,049.55)
<b>CHARGES FOR SERVICES</b>					
001-4-000-1-4534 COPIES	<u>10.00</u>	<u>0.00</u>	<u>0.00</u>	<u>0.00</u>	<u>10.00</u>
TOTAL CHARGES FOR SERVICES	10.00	0.00	0.00	0.00	10.00
<b>MISCELLANEOUS REVENUES</b>					
001-4-000-1-4735 MISC REVENUES	1,000.00	0.82	7,412.09	741.21 (	6,412.09)
001-4-000-1-4737 SALES TAX REFUNDS	2,000.00	0.00	0.00	0.00	2,000.00
001-4-000-4-4746 SALE OF OLD EQUIP/PROPERTY	<u>41,500.00</u>	<u>0.00</u>	<u>52,250.00</u>	<u>125.90 (</u>	<u>10,750.00)</u>
TOTAL MISCELLANEOUS REVENUES	44,500.00	0.82	59,662.09	134.07 (	15,162.09)

TOTAL Non Departmental 2,182,399.00 98,764.96 2,903,748.75 133.05 ( 721,349.75)

Police Department  
 =====

001-GENERAL FUND

100.00% OF YEAR COMP.

REVENUES	CURRENT BUDGET	CURRENT PERIOD	YEAR TO DATE ACTUAL	% OF BUDGET	BUDGET BALANCE
----------	----------------	----------------	---------------------	-------------	----------------

INTERGOVERNMENTAL

001-4-110-4-4490 SRO REIMBURSEMENT	52,665.00	0.00	45,294.35	86.00	7,370.65
TOTAL INTERGOVERNMENTAL	52,665.00	0.00	45,294.35	86.00	7,370.65

CHARGES FOR SERVICES

001-4-110-1-4550 POL SERV - REPORTS, FINGERPRNT	2,000.00	115.00	1,250.00	62.50	750.00
TOTAL CHARGES FOR SERVICES	2,000.00	115.00	1,250.00	62.50	750.00

MISCELLANEOUS REVENUES

001-4-110-1-4770 TICKETS AND COURT FINES	2,750.00	343.35	1,713.70	62.32	1,036.30
TOTAL MISCELLANEOUS REVENUES	2,750.00	343.35	1,713.70	62.32	1,036.30

OTHER FINANCING SOURCES

TOTAL Police Department	57,415.00	458.35	48,258.05	84.05	9,156.95
-------------------------	-----------	--------	-----------	-------	----------

Fire Department  
 =====

INTERGOVERNMENTAL

001-4-150-2-4475 FIRE SERVICE	127,196.41	36,813.99	127,494.40	100.23	( 297.99)
TOTAL INTERGOVERNMENTAL	127,196.41	36,813.99	127,494.40	100.23	( 297.99)

CHARGES FOR SERVICES

001-4-150-1-4500 CHARGES/FEES FOR SERVICE	0.00	0.00	1,609.43	0.00	( 1,609.43)
TOTAL CHARGES FOR SERVICES	0.00	0.00	1,609.43	0.00	( 1,609.43)

MISCELLANEOUS REVENUES

001-4-150-2-4710 REIMBURSEMENTS	11,683.00	0.00	9,793.63	83.83	1,889.37
TOTAL MISCELLANEOUS REVENUES	11,683.00	0.00	9,793.63	83.83	1,889.37

TOTAL Fire Department	138,879.41	36,813.99	138,897.46	100.01	( 18.05)
-----------------------	------------	-----------	------------	--------	----------

Animal Control  
 =====

LICENSES & PERMITS

001-4-190-1-4180 PET LICENSE	1,500.00	0.00	0.00	0.00	1,500.00
TOTAL LICENSES & PERMITS	1,500.00	0.00	0.00	0.00	1,500.00

TOTAL Animal Control	1,500.00	0.00	0.00	0.00	1,500.00
----------------------	----------	------	------	------	----------

001-GENERAL FUND

100.00% OF YEAR COMP.

REVENUES	CURRENT BUDGET	CURRENT PERIOD	YEAR TO DATE ACTUAL	% OF BUDGET	BUDGET BALANCE
----------	----------------	----------------	---------------------	-------------	----------------

Library  
 =====

INTERGOVERNMENTAL

001-4-410-2-4470 LIBRARY-COUNTY SERVICE	18,000.00	0.00	18,600.00	103.33	( 600.00)
TOTAL INTERGOVERNMENTAL	18,000.00	0.00	18,600.00	103.33	( 600.00)

MISCELLANEOUS REVENUES

001-4-410-1-4766 LIBRARY FINES & OPEN ACCESS	2,000.00	361.06	2,588.47	129.42	( 588.47)
001-4-410-1-4767 MEETING ROOM FEE	300.00	100.00	2,131.75	710.58	( 1,831.75)
TOTAL MISCELLANEOUS REVENUES	2,300.00	461.06	4,720.22	205.23	( 2,420.22)

TOTAL Library	20,300.00	461.06	23,320.22	114.88	( 3,020.22)
---------------	-----------	--------	-----------	--------	-------------

Museum  
 =====

OTHER FINANCING SOURCES

Parks  
 =====

LICENSES & PERMITS

001-4-430-1-4122 PARK FUND - SOUTH	0.00	0.00	8,734.00	0.00	( 8,734.00)
TOTAL LICENSES & PERMITS	0.00	0.00	8,734.00	0.00	( 8,734.00)

USE OF MONEY & PROPERTY

001-4-430-3-4310 CAMPGROUND RENT	8,232.00	0.00	6,860.00	83.33	1,372.00
TOTAL USE OF MONEY & PROPERTY	8,232.00	0.00	6,860.00	83.33	1,372.00

CHARGES FOR SERVICES

001-4-430-1-4556 PARK SHELTER RENT	1,200.00	267.50	2,083.05	173.59	( 883.05)
001-4-430-1-4566 PARK-DONATONS	0.00	0.00	7,500.00	0.00	( 7,500.00)
TOTAL CHARGES FOR SERVICES	1,200.00	267.50	9,583.05	798.59	( 8,383.05)

TOTAL Parks	9,432.00	267.50	25,177.05	266.93	( 15,745.05)
-------------	----------	--------	-----------	--------	--------------

Island Park  
 =====

CHARGES FOR SERVICES

001-GENERAL FUND

100.00% OF YEAR COMP.

REVENUES	CURRENT BUDGET	CURRENT PERIOD	YEAR TO DATE ACTUAL	% OF BUDGET	BUDGET BALANCE
----------	----------------	----------------	---------------------	-------------	----------------

Cemetery  
 =====

MISCELLANEOUS REVENUES

001-4-450-1-4740 CEMETERY STANDARD SPACE	13,000.00	3,500.00	22,000.00	169.23 (	9,000.00)
001-4-450-1-4742 REGULAR SPACE OPEN/CLOSE	5,000.00	500.00	5,800.00	116.00 (	800.00)
001-4-450-1-4743 CREMATION OPEN/CLOSE	<u>2,000.00</u>	<u>0.00</u>	<u>4,200.00</u>	<u>210.00</u> (	<u>2,200.00)</u>
TOTAL MISCELLANEOUS REVENUES	20,000.00	4,000.00	32,000.00	160.00 (	12,000.00)

TOTAL Cemetery	20,000.00	4,000.00	32,000.00	160.00 (	12,000.00)
----------------	-----------	----------	-----------	----------	------------

Pool  
 =====

CHARGES FOR SERVICES

001-4-460-1-4554 POOL ADMISSIONS	145,000.00	66,555.04	160,992.74	111.03 (	15,992.74)
001-4-460-1-4555 POOL-LESSONS	25,000.00	1,685.00	30,619.65	122.48 (	5,619.65)
001-4-460-1-4556 POOL BIRTHDAY PARTY PACKAGES	1,000.00	1,300.05	6,177.35	617.74 (	5,177.35)
001-4-460-1-4557 CONCESSIONS RECEIPTS	32,000.00	15,319.50	36,626.50	114.46 (	4,626.50)
001-4-460-1-4558 LIFEGUARD CLASSES	<u>1,000.00</u>	<u>0.00</u>	<u>2,575.00</u>	<u>257.50</u> (	<u>1,575.00)</u>
TOTAL CHARGES FOR SERVICES	204,000.00	84,859.59	236,991.24	116.17 (	32,991.24)

MISCELLANEOUS REVENUES

TOTAL Pool	204,000.00	84,859.59	236,991.24	116.17 (	32,991.24)
------------	------------	-----------	------------	----------	------------

Recreation  
 =====

USE OF MONEY & PROPERTY

001-4-470-4-4310 BALLFIELD RENTALS	<u>2,500.00</u>	<u>64.25</u>	<u>3,444.30</u>	<u>137.77</u> (	<u>944.30)</u>
TOTAL USE OF MONEY & PROPERTY	2,500.00	64.25	3,444.30	137.77 (	944.30)

CHARGES FOR SERVICES

001-4-470-1-4550 ARCHERY PERMITS	500.00	32.10	520.50	104.10 (	20.50)
001-4-470-1-4558 SOFTBALL REGISTRATIONS	11,000.00	0.00	11,330.00	103.00 (	330.00)
001-4-470-1-4559 BASEBALL REGISTRATION	22,000.00	400.00	24,950.00	113.41 (	2,950.00)
001-4-470-1-4560 SOCCER REGISTRATIONS	4,000.00	0.00	3,680.00	92.00	320.00
001-4-470-1-4561 FOOTBALL REGISTRATIONS	1,000.00	0.00	1,000.00	100.00	0.00
001-4-470-1-4562 ADULT LEAGUES	8,000.00	120.00	9,145.00	114.31 (	1,145.00)
001-4-470-1-4563 OTHER, SPONSORS	1,000.00	0.00	0.00	0.00	1,000.00
001-4-470-1-4564 YOUTH BASKETBALL	12,000.00	0.00	14,745.00	122.88 (	2,745.00)
001-4-470-1-4565 SPECIAL EVENTS	500.00	0.00	643.20	128.64 (	143.20)
001-4-470-1-4566 YOUTH TENNIS	3,500.00	420.00	4,900.00	140.00 (	1,400.00)
001-4-470-1-4568 ARCHERY LEAGUE REGISTRATIONS	<u>200.00</u>	<u>0.00</u>	<u>0.00</u>	<u>0.00</u>	<u>200.00)</u>
TOTAL CHARGES FOR SERVICES	63,700.00	972.10	70,913.70	111.32 (	7,213.70)

001-GENERAL FUND

100.00% OF YEAR COMP.

REVENUES	CURRENT BUDGET	CURRENT PERIOD	YEAR TO DATE ACTUAL	% OF BUDGET	BUDGET BALANCE
----------	----------------	----------------	---------------------	-------------	----------------

MISCELLANEOUS REVENUES

001-4-470-1-4736 CONCESSION REVENUE	4,500.00	3,526.85	9,181.88	204.04	( 4,681.88)
TOTAL MISCELLANEOUS REVENUES	4,500.00	3,526.85	9,181.88	204.04	( 4,681.88)

TOTAL Recreation	70,700.00	4,563.20	83,539.88	118.16	( 12,839.88)
------------------	-----------	----------	-----------	--------	--------------

Finance  
 =====

INTERGOVERNMENTAL

001-4-620-2-4440 STATE GRANTS	15,000.00	0.00	0.00	0.00	15,000.00
TOTAL INTERGOVERNMENTAL	15,000.00	0.00	0.00	0.00	15,000.00

MISCELLANEOUS REVENUES

001-4-620-2-4705 CONTRIBUTIONS-PRIV SOURCES	15,000.00	0.00	19,085.00	127.23	( 4,085.00)
TOTAL MISCELLANEOUS REVENUES	15,000.00	0.00	19,085.00	127.23	( 4,085.00)

TOTAL Finance	30,000.00	0.00	19,085.00	63.62	10,915.00
---------------	-----------	------	-----------	-------	-----------

Zoning/Compliance/Permits  
 =====

LICENSES & PERMITS

001-4-630-1-4120 BUILDING PERMITS	318,086.00	11,045.00	348,236.80	109.48	( 30,150.80)
001-4-630-1-4165 ZONING FEES	250.00	0.00	395.00	158.00	( 145.00)
001-4-630-1-4166 SUBDIVISION FEES	30,000.00	0.00	39,772.37	132.57	( 9,772.37)
TOTAL LICENSES & PERMITS	348,336.00	11,045.00	388,404.17	111.50	( 40,068.17)

TOTAL Zoning/Compliance/Permits	348,336.00	11,045.00	388,404.17	111.50	( 40,068.17)
---------------------------------	------------	-----------	------------	--------	--------------

Emergency Levy  
 =====

OTHER FINANCING SOURCES

001-4-690-4-4834 TRANSFER--EMERGENCY LEVY	56,874.00	0.00	58,090.53	102.14	( 1,216.53)
001-4-690-4-4836 OTHER TRANSFERS	896,639.00	1,861.00	898,498.96	100.21	( 1,859.96)
TOTAL OTHER FINANCING SOURCES	953,513.00	1,861.00	956,589.49	100.32	( 3,076.49)

TOTAL Emergency Levy	953,513.00	1,861.00	956,589.49	100.32	( 3,076.49)
----------------------	------------	----------	------------	--------	-------------

CITY OF ADEL  
REVENUE REPORT (UNAUDITED)  
AS OF: JUNE 30TH, 2024

001-GENERAL FUND

100.00% OF YEAR COMP.

REVENUES	CURRENT BUDGET	CURRENT PERIOD	YEAR TO DATE ACTUAL	% OF BUDGET	BUDGET BALANCE
Debt Service =====					
<u>OTHER FINANCING SOURCES</u>					
TOTAL REVENUE	4,036,474.41	243,094.65	4,856,011.31	120.30 (	819,536.90)
	=====	=====	=====	=====	=====

110-ROAD USE TAX

100.00% OF YEAR COMP.

REVENUES	CURRENT BUDGET	CURRENT PERIOD	YEAR TO DATE ACTUAL	% OF BUDGET	BUDGET BALANCE
Road Use Tax =====					
USE OF MONEY & PROPERTY	_____	_____	_____	_____	_____
INTERGOVERNMENTAL					
110-4-210-2-4430 RUT	<u>787,584.00</u>	<u>98,104.67</u>	<u>869,127.23</u>	<u>110.35</u>	( <u>81,543.23</u> )
TOTAL INTERGOVERNMENTAL	787,584.00	98,104.67	869,127.23	110.35	( 81,543.23)
MISCELLANEOUS REVENUES	_____	_____	_____	_____	_____
OTHER FINANCING SOURCES	_____	_____	_____	_____	_____
TOTAL Road Use Tax	787,584.00	98,104.67	869,127.23	110.35	( 81,543.23)
TOTAL REVENUE	<u>787,584.00</u>	<u>98,104.67</u>	<u>869,127.23</u>	<u>110.35</u>	( <u>81,543.23</u> )

600-WATER UTILITY

100.00% OF YEAR COMP.

REVENUES	CURRENT BUDGET	CURRENT PERIOD	YEAR TO DATE ACTUAL	% OF BUDGET	BUDGET BALANCE
<hr/>					
Water					
=====					
<hr/>					
USE OF MONEY & PROPERTY					
600-4-810-4-4300 INTEREST	<u>126,000.00</u>	<u>0.00</u>	<u>0.00</u>	<u>0.00</u>	<u>126,000.00</u>
TOTAL USE OF MONEY & PROPERTY	126,000.00	0.00	0.00	0.00	126,000.00
<hr/>					
INTERGOVERNMENTAL					
<hr/>					
CHARGES FOR SERVICES					
600-4-810-1-4500 WATER METERED SALES	1,911,939.00	136,633.94	1,963,323.09	102.69 (	51,384.09)
600-4-810-1-4501 WATER SERVICE EXCISE TAX	115,000.00	7,841.78	112,007.91	97.40	2,992.09
600-4-810-1-4511 BULK SALES	0.00	981.00	1,696.50	0.00 (	1,696.50)
600-4-810-1-4540 CONNECTING FEES	7,500.00	800.00	11,400.00	152.00 (	3,900.00)
600-4-810-1-4550 CWI SURCHARGE	<u>0.00</u>	<u>0.00</u>	<u>17.00</u>	<u>0.00</u>	<u>( 17.00)</u>
TOTAL CHARGES FOR SERVICES	2,034,439.00	146,256.72	2,088,444.50	102.65 (	54,005.50)
<hr/>					
MISCELLANEOUS REVENUES					
600-4-810-2-4716 MISC.- REFUNDS	<u>0.00</u>	<u>0.00</u>	<u>9,955.00</u>	<u>0.00</u>	<u>( 9,955.00)</u>
TOTAL MISCELLANEOUS REVENUES	0.00	0.00	9,955.00	0.00 (	9,955.00)
<hr/>					
OTHER FINANCING SOURCES					
<hr/>					
TOTAL Water	2,160,439.00	146,256.72	2,098,399.50	97.13	62,039.50
<hr/>					
TOTAL REVENUE	<u>2,160,439.00</u>	<u>146,256.72</u>	<u>2,098,399.50</u>	<u>97.13</u>	<u>62,039.50</u>
	=====	=====	=====	=====	=====

610-SEWER UTILITY FUND

100.00% OF YEAR COMP.

REVENUES	CURRENT BUDGET	CURRENT PERIOD	YEAR TO DATE ACTUAL	% OF BUDGET	BUDGET BALANCE
<hr/>					
Sewer					
=====					
<hr/>					
USE OF MONEY & PROPERTY					
610-4-815-4-4300 INTEREST	113,000.00	0.00	0.00	0.00	113,000.00
TOTAL USE OF MONEY & PROPERTY	113,000.00	0.00	0.00	0.00	113,000.00
<hr/>					
INTERGOVERNMENTAL					
<hr/>					
CHARGES FOR SERVICES					
610-4-815-1-4510 SEWER SERVICE FEES	1,684,151.00	134,898.42	1,794,001.27	106.52	( 109,850.27)
610-4-815-1-4541 SEWER CONNECTION FEE	80,100.00	3,200.00	89,700.00	111.99	( 9,600.00)
610-4-815-1-4550 CSI SURCHARGE	0.00	0.00	14.50	0.00	( 14.50)
TOTAL CHARGES FOR SERVICES	1,764,251.00	138,098.42	1,883,715.77	106.77	( 119,464.77)
<hr/>					
MISCELLANEOUS REVENUES					
<hr/>					
OTHER FINANCING SOURCES					
<hr/>					
TOTAL Sewer	1,877,251.00	138,098.42	1,883,715.77	100.34	( 6,464.77)
<hr/>					
TOTAL REVENUE	1,877,251.00	138,098.42	1,883,715.77	100.34	( 6,464.77)
	=====	=====	=====	=====	=====

615-STORM WATER UTILITY

100.00% OF YEAR COMP.

REVENUES	CURRENT BUDGET	CURRENT PERIOD	YEAR TO DATE ACTUAL	% OF BUDGET	BUDGET BALANCE
<hr/>					
STORM WATER UTILITY					
=====					
USE OF MONEY & PROPERTY					
-----					
CHARGES FOR SERVICES					
615-4-820-1-4510 SWU SERVICE FEE	162,603.00	13,604.19	166,152.45	102.18 (	3,549.45)
615-4-820-1-4550 CSWI SURCHARGE	<u>166,767.00</u>	<u>14,317.56</u>	<u>175,447.41</u>	<u>105.21</u> (	<u>8,680.41</u> )
TOTAL CHARGES FOR SERVICES	329,370.00	27,921.75	341,599.86	103.71 (	12,229.86)
MISCELLANEOUS REVENUES					
-----					
OTHER FINANCING SOURCES					
-----					
TOTAL STORM WATER UTILITY	329,370.00	27,921.75	341,599.86	103.71 (	12,229.86)
<hr/>					
TOTAL REVENUE	329,370.00	27,921.75	341,599.86	103.71 (	12,229.86)
	=====	=====	=====	=====	=====

CITY OF ADEL  
 EXPENDITURES REPORT (UNAUDITED)  
 AS OF: JUNE 30TH, 2024

001-GENERAL FUND

100.00% OF YEAR COMP.

Non Departmental

DEPARTMENTAL EXPENDITURES	CURRENT BUDGET	CURRENT PERIOD	YEAR TO DATE ACTUAL	% OF BUDGET	BUDGET BALANCE
<b>TRANSFERS</b>					
001-5-000-5-6910 TRANSFER OUT	16,687.00	0.00	88,775.85	532.01 (	72,088.85)
TOTAL TRANSFERS	16,687.00	0.00	88,775.85	532.01 (	72,088.85)
TOTAL Non Departmental	16,687.00	0.00	88,775.85	532.01 (	72,088.85)

001-GENERAL FUND 100.00% OF YEAR COMP.

Police Department

DEPARTMENTAL EXPENDITURES	CURRENT BUDGET	CURRENT PERIOD	YEAR TO DATE ACTUAL	% OF BUDGET	BUDGET BALANCE
---------------------------	----------------	----------------	---------------------	-------------	----------------

PERSONAL SERVICES

001-5-110-1-6010 FULL TIME WAGES	823,813.00	66,524.54	775,534.57	94.14	48,278.43
001-5-110-1-6020 PART TIME WAGES	12,000.00	478.01	20,493.94	170.78 (	8,493.94)
001-5-110-1-6040 OVERTIME WAGES	8,000.00	560.72	9,421.23	117.77 (	1,421.23)
001-5-110-1-6062 HOLIDAY WAGES	18,000.00	1,906.88	16,968.63	94.27	1,031.37
001-5-110-1-6069 COURT TIME WAGES	1,000.00	0.00	1,018.58	101.86 (	18.58)
001-5-110-1-6181 UNIFORM ALLOWANCE	11,708.00	0.00	11,707.44	100.00	0.56
001-5-110-1-6210 DUES, MEMBERSHIPS, SUBSCRIPTIO	400.00	0.00	134.83	33.71	265.17
001-5-110-1-6230 EDUCATION & TRAINING	6,000.00	0.00	6,545.56	109.09 (	545.56)
001-5-110-1-6231 ACADEMY TRAINING	9,000.00	0.00	0.00	0.00	9,000.00
001-5-110-1-6240 MEETINGS AND TRAVEL	<u>2,000.00</u>	<u>136.46</u>	<u>1,020.43</u>	<u>51.02</u>	<u>979.57</u>
TOTAL PERSONAL SERVICES	891,921.00	69,606.61	842,845.21	94.50	49,075.79

SERVICES AND COMMODITIES

001-5-110-2-6331 VEHICLE FUEL-OIL-LUBRICANTS	24,000.00	3,089.20	24,332.31	101.38 (	332.31)
001-5-110-2-6332 VEHICLE, EQUIP & RADIO MAINT.	20,000.00	4,332.46	20,676.96	103.38 (	676.96)
001-5-110-2-6371 UTILITIES-ELEC,GAS-SANITATION	10,000.00	562.83	8,705.56	87.06	1,294.44
001-5-110-2-6372 DISASTER SERVICES	5,000.00	5,655.99	9,353.26	187.07 (	4,353.26)
001-5-110-2-6373 TELEPHONE/RADIO	9,800.00	822.13	11,181.74	114.10 (	1,381.74)
001-5-110-2-6402 ADVERTISING & LEGAL PUBLICATIO	2,000.00	11.40	45.40	2.27	1,954.60
001-5-110-2-6407 PROFESS FEES-DRS, LAWYERS, ENG	9,259.00	60.00	9,551.02	103.15 (	292.02)
001-5-110-2-6408 INSURANCE-FIRE & AUTO-GENERAL	21,731.00	0.00	7,243.27	33.33	14,487.73
001-5-110-2-6411 COURT COSTS	350.00	5.00	90.00	25.71	260.00
001-5-110-2-6413 PMTS TO OTHER AGENCIES	5,000.00	0.00	1,520.25	30.41	3,479.75
001-5-110-2-6419 DATA PROCESSING EXPENSES	16,000.00	322.00	16,153.99	100.96 (	153.99)
001-5-110-2-6426 BUILDING & GROUNDS MAINTENANCE	8,000.00	450.00	6,642.31	83.03	1,357.69
001-5-110-2-6432 SERVICE/MAINT AGREEMENTS	3,500.00	138.34	3,600.13	102.86 (	100.13)
001-5-110-2-6506 OFFICE SUPPLIES	3,250.00	105.06	2,819.90	86.77	430.10
001-5-110-2-6516 FILM & PROCESSING	500.00	0.00	0.00	0.00	500.00
001-5-110-2-6598 PETTY CASH & MISCELLANEOUS	200.00	0.00	74.01	37.01	125.99
001-5-110-2-6599 MISC SUPPLIES	<u>2,000.00</u>	<u>0.00</u>	<u>2,158.66</u>	<u>107.93 (</u>	<u>158.66)</u>
TOTAL SERVICES AND COMMODITIES	140,590.00	15,554.41	124,148.77	88.31	16,441.23

CAPITAL OUTLAY

001-5-110-3-6711 CAPITAL OUTLAY-VEHICLE	82,893.00	0.00	82,892.84	100.00	0.16
001-5-110-3-6726 EQUIPMENT UPGRADE	<u>26,879.00</u>	<u>799.99</u>	<u>26,102.49</u>	<u>97.11</u>	<u>776.51</u>
TOTAL CAPITAL OUTLAY	109,772.00	799.99	108,995.33	99.29	776.67

TRANSFERS

TOTAL Police Department	1,142,283.00	85,961.01	1,075,989.31	94.20	66,293.69
-------------------------	--------------	-----------	--------------	-------	-----------

001-GENERAL FUND

100.00% OF YEAR COMP.

Fire Department

DEPARTMENTAL EXPENDITURES	CURRENT BUDGET	CURRENT PERIOD	YEAR TO DATE ACTUAL	% OF BUDGET	BUDGET BALANCE
<u>PERSONAL SERVICES</u>					
001-5-150-1-6050 FIRE CALL STIPEND	24,000.00	0.00	28,085.00	117.02 (	4,085.00)
001-5-150-1-6052 FIRST RESPONDERS	9,000.00	936.47	7,901.31	87.79	1,098.69
001-5-150-1-6210 DUES, MEMBERSHIPS, SUBSCRIPTIO	400.00	0.00	397.00	99.25	3.00
001-5-150-1-6230 EDUCATION & TRAINING	3,500.00	0.00	3,204.60	91.56	295.40
001-5-150-1-6260 AWARDS	<u>500.00</u>	<u>0.00</u>	<u>113.95</u>	<u>22.79</u>	<u>386.05</u>
TOTAL PERSONAL SERVICES	37,400.00	936.47	39,701.86	106.15 (	2,301.86)
<u>SERVICES AND COMMODITIES</u>					
001-5-150-2-6331 VEHICLE FUEL-OIL-LUBRICANTS	3,000.00	98.34	3,595.65	119.86 (	595.65)
001-5-150-2-6332 VEHICLE, EQUIP & RADIO MAINT.	12,000.00	530.60	10,971.93	91.43	1,028.07
001-5-150-2-6371 UTILITIES-ELEC,GAS-SANITATION	2,000.00	17.88	911.90	45.60	1,088.10
001-5-150-2-6373 TELEPHONE/RADIO	3,800.00	263.00	4,463.59	117.46 (	663.59)
001-5-150-2-6402 ADVERTISING & LEGAL PUBLICATIO	0.00	0.00	132.48	0.00 (	132.48)
001-5-150-2-6407 PROFESS FEES-DRS, LAWYERS, ENG	4,000.00	0.00	2,212.50	55.31	1,787.50
001-5-150-2-6408 INSURANCE-FIRE & AUTO-GENERAL	20,472.00	0.00	6,823.74	33.33	13,648.26
001-5-150-2-6419 DATA PROCESSING EXPENSES	3,500.00	6.00	1,342.48	38.36	2,157.52
001-5-150-2-6426 BUILDING & GROUNDS MAINTENANCE	7,500.00	3,438.40	3,438.40	45.85	4,061.60
001-5-150-2-6432 SERVICE/MAINT AGREEMENTS	700.00	0.00	724.00	103.43 (	24.00)
001-5-150-2-6504 MINOR EQUIPMENT	20,000.00	6,104.46	12,107.19	60.54	7,892.81
001-5-150-2-6506 OFFICE SUPPLIES	500.00	37.59	112.05	22.41	387.95
001-5-150-2-6514 BUNKER GEAR/EQUIP	10,000.00	7,569.87	7,569.87	75.70	2,430.13
001-5-150-2-6517 HEPATITUS B-VACINATIONS	250.00	0.00	0.00	0.00	250.00
001-5-150-2-6518 UNIFORMS	5,000.00	0.00	4,681.33	93.63	318.67
001-5-150-2-6519 FIRE GROUND EXPENSE	500.00	0.00	117.01	23.40	382.99
001-5-150-2-6520 FIRE PREVENTION EXPENSES	1,000.00	0.00	230.00	23.00	770.00
001-5-150-2-6521 AIR COMPRESSOR	1,000.00	0.00	1,061.21	106.12 (	61.21)
001-5-150-2-6598 REFUNDS	0.00	0.00	297.95	0.00 (	297.95)
001-5-150-2-6599 MISC SUPPLIES	<u>1,000.00</u>	<u>21.49</u>	<u>1,027.73</u>	<u>102.77</u> (	<u>27.73)</u>
TOTAL SERVICES AND COMMODITIES	96,222.00	18,087.63	61,821.01	64.25	34,400.99
<u>CAPITAL OUTLAY</u>					
001-5-150-3-6711 CAPITAL OUTLAY-VEHICLE/EQUIP	<u>80,000.00</u>	<u>0.00</u>	<u>80,071.07</u>	<u>100.09</u> (	<u>71.07)</u>
TOTAL CAPITAL OUTLAY	80,000.00	0.00	80,071.07	100.09 (	71.07)
TOTAL Fire Department	213,622.00	19,024.10	181,593.94	85.01	32,028.06

CITY OF ADEL  
 EXPENDITURES REPORT (UNAUDITED)  
 AS OF: JUNE 30TH, 2024

001-GENERAL FUND

100.00% OF YEAR COMP.

Animal Control

DEPARTMENTAL EXPENDITURES	CURRENT BUDGET	CURRENT PERIOD	YEAR TO DATE ACTUAL	% OF BUDGET	BUDGET BALANCE
<u>SERVICES AND COMMODITIES</u>					
001-5-190-2-6421 ANIMAL CONTROL	2,000.00	0.00	250.00	12.50	1,750.00
TOTAL SERVICES AND COMMODITIES	2,000.00	0.00	250.00	12.50	1,750.00
TOTAL Animal Control	2,000.00	0.00	250.00	12.50	1,750.00

CITY OF ADEL  
EXPENDITURES REPORT (UNAUDITED)  
AS OF: JUNE 30TH, 2024

001-GENERAL FUND

100.00% OF YEAR COMP.

Roads, Bridges, Sidewalks

DEPARTMENTAL EXPENDITURES	CURRENT BUDGET	CURRENT PERIOD	YEAR TO DATE ACTUAL	% OF BUDGET	BUDGET BALANCE
<u>SERVICES AND COMMODITIES</u>					
001-5-210-2-6408 INSURANCE	29,729.00	0.00	9,909.17	33.33	19,819.83
TOTAL SERVICES AND COMMODITIES	29,729.00	0.00	9,909.17	33.33	19,819.83
<u>CAPITAL OUTLAY</u>					
TOTAL Roads, Bridges, Sidewalks	29,729.00	0.00	9,909.17	33.33	19,819.83

CITY OF ADEL  
 EXPENDITURES REPORT (UNAUDITED)  
 AS OF: JUNE 30TH, 2024

001-GENERAL FUND

100.00% OF YEAR COMP.

Street Lighting

DEPARTMENTAL EXPENDITURES	CURRENT BUDGET	CURRENT PERIOD	YEAR TO DATE ACTUAL	% OF BUDGET	BUDGET BALANCE
<hr/>					
<u>SERVICES AND COMMODITIES</u>					
001-5-230-2-6375 STREET LIGHTING	<u>58,000.00</u>	<u>4,886.58</u>	<u>57,780.89</u>	<u>99.62</u>	<u>219.11</u>
TOTAL SERVICES AND COMMODITIES	58,000.00	4,886.58	57,780.89	99.62	219.11
<hr/>					
TOTAL Street Lighting	58,000.00	4,886.58	57,780.89	99.62	219.11

CITY OF ADEL  
EXPENDITURES REPORT (UNAUDITED)  
AS OF: JUNE 30TH, 2024

001-GENERAL FUND

100.00% OF YEAR COMP.

Traffic Control & Safety

DEPARTMENTAL EXPENDITURES	CURRENT BUDGET	CURRENT PERIOD	YEAR TO DATE ACTUAL	% OF BUDGET	BUDGET BALANCE
<u>SERVICES AND COMMODITIES</u>					
001-5-240-2-6374 TRAFFIC CONTROL	<u>8,132.00</u>	<u>31.99</u>	<u>385.09</u>	<u>4.74</u>	<u>7,746.91</u>
TOTAL SERVICES AND COMMODITIES	8,132.00	31.99	385.09	4.74	7,746.91
<hr/>					
TOTAL Traffic Control & Safety	8,132.00	31.99	385.09	4.74	7,746.91

CITY OF ADEL  
 EXPENDITURES REPORT (UNAUDITED)  
 AS OF: JUNE 30TH, 2024

001-GENERAL FUND

100.00% OF YEAR COMP.

Library

DEPARTMENTAL EXPENDITURES	CURRENT BUDGET	CURRENT PERIOD	YEAR TO DATE ACTUAL	% OF BUDGET	BUDGET BALANCE
<u>PERSONAL SERVICES</u>					
001-5-410-1-6010 FULL TIME WAGES	238,514.00	21,684.21	238,227.49	99.88	286.51
001-5-410-1-6020 PART TIME WAGES	61,104.00	2,236.06	54,279.30	88.83	6,824.70
001-5-410-1-6210 DUES, MEMBERSHIPS, SUBSCRIPTIO	800.00	0.00	782.82	97.85	17.18
001-5-410-1-6230 EDUCATION & TRAINING	<u>1,500.00</u>	<u>0.00</u>	<u>1,492.33</u>	<u>99.49</u>	<u>7.67</u>
TOTAL PERSONAL SERVICES	301,918.00	23,920.27	294,781.94	97.64	7,136.06
<u>SERVICES AND COMMODITIES</u>					
001-5-410-2-6371 UTILITIES-ELEC,GAS-SANITATION	24,000.00	2,061.17	23,516.51	97.99	483.49
001-5-410-2-6373 TELEPHONE/RADIO	10,850.00	2,841.56	12,115.44	111.66 (	1,265.44)
001-5-410-2-6402 ADVERTISING & LEGAL PUBLICATIO	500.00	0.00	410.88	82.18	89.12
001-5-410-2-6407 PROFESS FEES-DRS, LAWYERS, ENG	0.00	0.00	229.00	0.00 (	229.00)
001-5-410-2-6408 INSURANCE-FIRE & AUTO-GENERAL	16,458.00	0.00	5,485.87	33.33	10,972.13
001-5-410-2-6419 DATA PROCESSING EXPENSES	9,400.00	0.00	9,498.00	101.04 (	98.00)
001-5-410-2-6423 SERVICE AGREEMENTS	17,400.00	1,993.88	17,201.23	98.86	198.77
001-5-410-2-6426 BUILDING & GROUNDS MAINTENANCE	15,000.00	2,994.51	16,496.37	109.98 (	1,496.37)
001-5-410-2-6508 POSTAGE AND SHIPPING	300.00	0.00	277.46	92.49	22.54
001-5-410-2-6523 PROGRAM EXPENSE	3,340.00	15.75	3,302.78	98.89	37.22
001-5-410-2-6524 BOOK PROCESSING SUPPLIES	3,000.00	410.89	2,877.08	95.90	122.92
001-5-410-2-6598 PETTY CASH & MISCELLANEOUS	300.00	269.61	285.59	95.20	14.41
001-5-410-2-6599 MISC SUPPLIES	<u>4,500.00</u>	<u>733.20</u>	<u>4,612.32</u>	<u>102.50 (</u>	<u>112.32)</u>
TOTAL SERVICES AND COMMODITIES	105,048.00	11,320.57	96,308.53	91.68	8,739.47
<u>CAPITAL OUTLAY</u>					
001-5-410-3-6770 CAPITAL OUTLAY-BOOKS, FILMS, R	<u>40,000.00</u>	<u>4,630.15</u>	<u>37,610.05</u>	<u>94.03</u>	<u>2,389.95</u>
TOTAL CAPITAL OUTLAY	40,000.00	4,630.15	37,610.05	94.03	2,389.95
TOTAL Library	446,966.00	39,870.99	428,700.52	95.91	18,265.48

CITY OF ADEL  
EXPENDITURES REPORT (UNAUDITED)  
AS OF: JUNE 30TH, 2024

001-GENERAL FUND

100.00% OF YEAR COMP.

Museum

DEPARTMENTAL EXPENDITURES	CURRENT BUDGET	CURRENT PERIOD	YEAR TO DATE ACTUAL	% OF BUDGET	BUDGET BALANCE
<u>SERVICES AND COMMODITIES</u>					
001-5-420-2-6534 HISTORICAL MUSEUM EXPENSE	29,905.00	250.92	23,695.74	79.24	6,209.26
TOTAL SERVICES AND COMMODITIES	29,905.00	250.92	23,695.74	79.24	6,209.26
TOTAL Museum	29,905.00	250.92	23,695.74	79.24	6,209.26

001-GENERAL FUND

100.00% OF YEAR COMP.

Parks

DEPARTMENTAL EXPENDITURES	CURRENT BUDGET	CURRENT PERIOD	YEAR TO DATE ACTUAL	% OF BUDGET	BUDGET BALANCE
<u>PERSONAL SERVICES</u>					
001-5-430-1-6010 FULL TIME WAGES	117,025.00	9,726.31	104,818.79	89.57	12,206.21
001-5-430-1-6020 PART TIME WAGES	32,448.00	3,878.70	19,172.30	59.09	13,275.70
001-5-430-1-6040 OVERTIME WAGES	600.00	0.00	858.49	143.08 (	258.49)
001-5-430-1-6210 DUES, MEMBERSHIPS, SUBSCRIPTIO	1,226.00	0.00	270.00	22.02	956.00
001-5-430-1-6230 EDUCATION & TRAINING	950.00	0.00	1,170.00	123.16 (	220.00)
001-5-430-1-6240 MEETING & TRAVEL	<u>1,000.00</u>	<u>0.00</u>	<u>1,143.88</u>	<u>114.39 (</u>	<u>143.88)</u>
TOTAL PERSONAL SERVICES	153,249.00	13,605.01	127,433.46	83.15	25,815.54
<u>SERVICES AND COMMODITIES</u>					
001-5-430-2-6322 MULCH	7,000.00	1,930.50	1,930.50	27.58	5,069.50
001-5-430-2-6331 VEHICLE FUEL-OIL-LUBRICANTS	8,000.00	336.15	7,407.09	92.59	592.91
001-5-430-2-6332 VEHICLE, EQUIP & RADIO MAINT.	7,000.00	1,185.64	4,743.29	67.76	2,256.71
001-5-430-2-6371 UTILITIES-ELEC,GAS-SANITATION	18,500.00	521.08	13,296.53	71.87	5,203.47
001-5-430-2-6373 TELEPHONE/RADIO	2,965.00	175.33	4,103.94	138.41 (	1,138.94)
001-5-430-2-6402 ADVERTISING & LEGAL PUBLICATIO	1,250.00	0.00	30.00	2.40	1,220.00
001-5-430-2-6407 PROFESS FEES-DRS, LAWYERS, ENG	2,000.00	0.00	2,255.21	112.76 (	255.21)
001-5-430-2-6408 INSURANCE-FIRE & AUTO-GENERAL	22,467.00	0.00	7,488.95	33.33	14,978.05
001-5-430-2-6416 RENTALS	3,000.00	28.14	970.70	32.36	2,029.30
001-5-430-2-6418 PROPERTY TAXES	1,000.00	0.00	3,513.15	351.32 (	2,513.15)
001-5-430-2-6419 DATA PROCESSING EXPENSES	525.00	18.00	567.50	108.10 (	42.50)
001-5-430-2-6424 TREE CARE	15,500.00	8,699.56	14,611.00	94.26	889.00
001-5-430-2-6426 BUILDING & GROUNDS MAINTENANCE	36,167.00	11,655.27	34,502.08	95.40	1,664.92
001-5-430-2-6432 SERVICE & MAINT AGREEMENTS	1,500.00	259.71	3,001.79	200.12 (	1,501.79)
001-5-430-2-6501 CHEMICALS	4,500.00	0.00	3,652.33	81.16	847.67
001-5-430-2-6506 OFFICE SUPPLIES	1,000.00	163.47	1,597.35	159.74 (	597.35)
001-5-430-2-6598 PETTY CASH & MISCELLANEOUS	50.00	0.00	83.09	166.18 (	33.09)
001-5-430-2-6599 MISC SUPPLIES	<u>2,500.00</u>	<u>60.00</u>	<u>3,052.66</u>	<u>122.11 (</u>	<u>552.66)</u>
TOTAL SERVICES AND COMMODITIES	134,924.00	25,032.85	106,807.16	79.16	28,116.84
<u>CAPITAL OUTLAY</u>					
001-5-430-3-6711 CAPITAL OUTLAY-VEHICLE	24,750.00	0.00	0.00	0.00	24,750.00
001-5-430-3-6713 CAPITAL OUTLAY-BUILDING	157,403.00	33,774.18	170,025.04	108.02 (	12,622.04)
001-5-430-3-6730 CAPITAL OUTLAY-LAND	<u>50,175.00</u>	<u>5,525.00</u>	<u>41,750.61</u>	<u>83.21</u>	<u>8,424.39</u>
TOTAL CAPITAL OUTLAY	232,328.00	39,299.18	211,775.65	91.15	20,552.35
TOTAL Parks	520,501.00	77,937.04	446,016.27	85.69	74,484.73

CITY OF ADEL  
EXPENDITURES REPORT (UNAUDITED)  
AS OF: JUNE 30TH, 2024

001-GENERAL FUND

100.00% OF YEAR COMP.

Island Park

DEPARTMENTAL EXPENDITURES	CURRENT BUDGET	CURRENT PERIOD	YEAR TO DATE ACTUAL	% OF BUDGET	BUDGET BALANCE
---------------------------	----------------	----------------	---------------------	-------------	----------------

PERSONAL SERVICES

_____	_____	_____	_____	_____	_____
-------	-------	-------	-------	-------	-------

SERVICES AND COMMODITIES

_____	_____	_____	_____	_____	_____
-------	-------	-------	-------	-------	-------

CITY OF ADEL  
 EXPENDITURES REPORT (UNAUDITED)  
 AS OF: JUNE 30TH, 2024

001-GENERAL FUND

100.00% OF YEAR COMP.

Cemetery

DEPARTMENTAL EXPENDITURES	CURRENT BUDGET	CURRENT PERIOD	YEAR TO DATE ACTUAL	% OF BUDGET	BUDGET BALANCE
<u>PERSONAL SERVICES</u>					
001-5-450-1-6010 FULL TIME WAGES	32,488.00	2,712.42	28,736.06	88.45	3,751.94
001-5-450-1-6030 PART TIME WAGES	<u>10,816.00</u>	<u>1,292.90</u>	<u>6,390.80</u>	<u>59.09</u>	<u>4,425.20</u>
TOTAL PERSONAL SERVICES	43,304.00	4,005.32	35,126.86	81.12	8,177.14
<u>SERVICES AND COMMODITIES</u>					
001-5-450-2-6331 VEHICLE FUEL-OIL-LUBRICANTS	2,200.00	0.00	0.00	0.00	2,200.00
001-5-450-2-6332 VEHICLE, EQUIP & RADIO MAINT.	2,000.00	1,092.71	1,806.11	90.31	193.89
001-5-450-2-6419 DATA PROCESSING EXPENSE	11,700.00	0.00	12,466.00	106.55 (	766.00)
001-5-450-2-6424 TREE CARE	2,100.00	0.00	534.60	25.46	1,565.40
001-5-450-2-6425 CONTRACTED MOWING	8,000.00	0.00	7,287.50	91.09	712.50
001-5-450-2-6426 BUILDING & GROUNDS MAINTENANCE	10,200.00	0.00	10,897.75	106.84 (	697.75)
001-5-450-2-6432 SERVICE & MAINT AGREEMENTS	600.00	0.00	801.01	133.50 (	201.01)
001-5-450-2-6440 REFUNDS	700.00	500.00	800.00	114.29 (	100.00)
001-5-450-2-6504 MINOR EQUIPMENT	400.00	0.00	556.77	139.19 (	156.77)
001-5-450-2-6599 MISC SUPPLIES	<u>600.00</u>	<u>0.00</u>	<u>540.24</u>	<u>90.04</u>	<u>59.76</u>
TOTAL SERVICES AND COMMODITIES	38,500.00	1,592.71	35,689.98	92.70	2,810.02
TOTAL Cemetery	81,804.00	5,598.03	70,816.84	86.57	10,987.16

001-GENERAL FUND

100.00% OF YEAR COMP.

Pool

DEPARTMENTAL EXPENDITURES	CURRENT BUDGET	CURRENT PERIOD	YEAR TO DATE ACTUAL	% OF BUDGET	BUDGET BALANCE
<u>PERSONAL SERVICES</u>					
001-5-460-1-6010 FULL TIME WAGES	65,487.00	5,413.48	67,220.52	102.65 (	1,733.52)
001-5-460-1-6011 PART TIME WAGES	104,000.00	33,809.17	93,334.03	89.74	10,665.97
001-5-460-1-6030 SEASONAL WAGES - CONCESSIONS	20,000.00	4,132.51	12,203.39	61.02	7,796.61
001-5-460-1-6031 SEASONAL WAGES - ADMISSIONS	20,000.00	3,228.63	9,334.38	46.67	10,665.62
001-5-460-1-6230 EDUCATION & TRAINING	<u>6,000.00</u>	<u>2,000.00</u>	<u>3,546.00</u>	<u>59.10</u>	<u>2,454.00</u>
TOTAL PERSONAL SERVICES	215,487.00	48,583.79	185,638.32	86.15	29,848.68
<u>SERVICES AND COMMODITIES</u>					
001-5-460-2-6371 UTILITIES-ELEC,GAS-SANITATION	18,000.00	1,289.76	15,871.90	88.18	2,128.10
001-5-460-2-6373 TELEPHONE/RADIO	1,800.00	45.27	1,848.20	102.68 (	48.20)
001-5-460-2-6402 ADVERTISING & LEGAL PUBLICATIO	400.00	0.00	316.60	79.15	83.40
001-5-460-2-6407 PROFESS FEES-DRS, LAWYERS, ENG	4,000.00	0.00	553.00	13.83	3,447.00
001-5-460-2-6408 INSURANCE-FIRE & AUTO-GENERAL	22,875.00	0.00	7,624.73	33.33	15,250.27
001-5-460-2-6418 SALES TAX	10,500.00	2,692.79	10,239.43	97.52	260.57
001-5-460-2-6426 BUILDING & GROUNDS MAINTENANCE	12,500.00	9,567.24	17,845.77	142.77 (	5,345.77)
001-5-460-2-6432 SERVICE MAINT & AGREEMENTS	8,470.00	5,335.27	14,072.11	166.14 (	5,602.11)
001-5-460-2-6433 TESTING	100.00	14.50	48.00	48.00	52.00
001-5-460-2-6435 INSPECTIONS	650.00	0.00	0.00	0.00	650.00
001-5-460-2-6440 REFUNDS-POOL	0.00	60.00	60.00	0.00 (	60.00)
001-5-460-2-6501 CHEMICALS	12,000.00	799.60	12,511.10	104.26 (	511.10)
001-5-460-2-6504 MINOR EQUIPMENT	3,500.00	713.32	2,619.94	74.86	880.06
001-5-460-2-6505 CONCESSION SUPPLIES	26,000.00	8,349.75	23,659.91	91.00	2,340.09
001-5-460-2-6599 MISC SUPPLIES	<u>4,000.00</u>	<u>464.80</u>	<u>3,770.23</u>	<u>94.26</u>	<u>229.77</u>
TOTAL SERVICES AND COMMODITIES	124,795.00	29,332.30	111,040.92	88.98	13,754.08
<u>CAPITAL OUTLAY</u>					
001-5-460-3-6712 CAPITAL OUTLAY-BUILDING	<u>83,029.00</u>	<u>0.00</u>	<u>83,029.00</u>	<u>100.00</u>	<u>0.00</u>
TOTAL CAPITAL OUTLAY	83,029.00	0.00	83,029.00	100.00	0.00
TOTAL Pool	423,311.00	77,916.09	379,708.24	89.70	43,602.76

001-GENERAL FUND

100.00% OF YEAR COMP.

DEPARTMENTAL EXPENDITURES	CURRENT BUDGET	CURRENT PERIOD	YEAR TO DATE ACTUAL	% OF BUDGET	BUDGET BALANCE
<u>PERSONAL SERVICES</u>					
001-5-470-1-6010 FULL TIME WAGES	103,226.00	8,535.70	99,468.22	96.36	3,757.78
001-5-470-1-6020 PART TIME WAGES	17,016.00	3,228.78	14,831.69	87.16	2,184.31
001-5-470-1-6021 OFFICIALS/SCOREKEEPERS WAGES	12,000.00	1,290.00	11,561.25	96.34	438.75
001-5-470-1-6210 DUES, MEMBERSHIPS, SUBSCRIPTIO	2,300.00	0.00	980.00	42.61	1,320.00
001-5-470-1-6230 EDUCATION & TRAINING	1,950.00	0.00	300.00	15.38	1,650.00
001-5-470-1-6240 MEETING & TRAVEL	<u>1,550.00</u>	<u>0.00</u>	<u>156.50</u>	<u>10.10</u>	<u>1,393.50</u>
TOTAL PERSONAL SERVICES	138,042.00	13,054.48	127,297.66	92.22	10,744.34
<u>SERVICES AND COMMODITIES</u>					
001-5-470-2-6331 VEHICLE FUEL-OIL-LUBRICANTS	3,000.00	190.13	1,573.14	52.44	1,426.86
001-5-470-2-6332 VEHICLE, EQUIP & RADIO MAINT.	1,000.00	0.00	991.07	99.11	8.93
001-5-470-2-6373 TELEPHONE/RADIO	1,200.00	0.00	816.63	68.05	383.37
001-5-470-2-6402 ADVERTISING & LEGAL PUBLICATIO	12,000.00	0.00	8,864.96	73.87	3,135.04
001-5-470-2-6403 INSURANCE-LIABILITY	3,234.00	0.00	1,077.69	33.32	2,156.31
001-5-470-2-6407 PROFESS FEES-DRS, LAWYERS, ENG	0.00	0.00	57.00	0.00 (	57.00)
001-5-470-2-6416 RENTALS	3,500.00	0.00	113.00	3.23	3,387.00
001-5-470-2-6418 SALES TAX	2,000.00	0.00	0.00	0.00	2,000.00
001-5-470-2-6419 DATA PROCESSING EXPENSES	600.00	33.81	542.83	90.47	57.17
001-5-470-2-6426 BUILDING & GROUNDS MAINTENANCE	14,000.00	1,681.36	13,566.45	96.90	433.55
001-5-470-2-6432 SERVICE & MAINT AGREEMENTS	3,100.00	677.40	3,500.95	112.93 (	400.95)
001-5-470-2-6436 CONCESSION EXPENSES	4,500.00	1,449.04	4,983.99	110.76 (	483.99)
001-5-470-2-6505 CONCESSION SUPPLIES	0.00	107.96	107.96	0.00 (	107.96)
001-5-470-2-6506 OFFICE SUPPLIES	1,000.00	163.47	1,683.11	168.31 (	683.11)
001-5-470-2-6509 YOUTH BASKETBALL	4,200.00	0.00	2,351.72	55.99	1,848.28
001-5-470-2-6510 SPECIAL EVENTS	4,000.00	7,640.29	10,459.43	261.49 (	6,459.43)
001-5-470-2-6512 ADULT LEAGUE EXPENSE	4,200.00	369.71	1,818.70	43.30	2,381.30
001-5-470-2-6535 FIRST AID SUPPLIES	100.00	0.00	0.00	0.00	100.00
001-5-470-2-6536 BASEBALL EXPENSE	13,500.00	366.23	6,310.94	46.75	7,189.06
001-5-470-2-6537 SOFTBALL EXPENSE	9,000.00	366.24	3,913.32	43.48	5,086.68
001-5-470-2-6539 SOCCER EXPENSE	500.00	0.00	876.64	175.33 (	376.64)
001-5-470-2-6541 TENNIS EXPENSE	1,000.00	0.00	0.00	0.00	1,000.00
001-5-470-2-6542 ESPORTS EXPENSE	1,600.00	0.00	0.00	0.00	1,600.00
001-5-470-2-6599 MISC SUPPLIES	<u>10,000.00</u>	<u>1,135.96</u>	<u>8,211.82</u>	<u>82.12</u>	<u>1,788.18</u>
TOTAL SERVICES AND COMMODITIES	97,234.00	14,181.60	71,821.35	73.86	25,412.65
<u>CAPITAL OUTLAY</u>					
001-5-470-3-6711 CAPITAL OUTLAY-VEHICLE	<u>6,000.00</u>	<u>0.00</u>	<u>0.00</u>	<u>0.00</u>	<u>6,000.00</u>
TOTAL CAPITAL OUTLAY	6,000.00	0.00	0.00	0.00	6,000.00
TOTAL Recreation	241,276.00	27,236.08	199,119.01	82.53	42,156.99

001-GENERAL FUND

100.00% OF YEAR COMP.

Finance

DEPARTMENTAL EXPENDITURES	CURRENT BUDGET	CURRENT PERIOD	YEAR TO DATE ACTUAL	% OF BUDGET	BUDGET BALANCE
---------------------------	----------------	----------------	---------------------	-------------	----------------

PERSONAL SERVICES

001-5-620-1-6010 FULL TIME WAGES	59,838.00	6,208.50	59,580.88	99.57	257.12
001-5-620-1-6011 MAYOR AND COUNCIL WAGES	3,135.00	0.00	3,135.00	100.00	0.00
001-5-620-1-6020 PART TIME WAGES	6,578.00	0.00	7,911.45	120.27 (	1,333.45)
001-5-620-1-6040 OVERTIME WAGES	1,000.00	0.00	0.00	0.00	1,000.00
001-5-620-1-6210 DUES, MEMBERSHIPS, SUBSCRIPTIO	15,500.00	3,480.04	14,442.03	93.17	1,057.97
001-5-620-1-6230 EDUCATION & TRAINING	4,000.00	935.00	3,807.02	95.18	192.98
001-5-620-1-6240 MEETINGS AND TRAVEL	4,500.00	0.00	1,173.96	26.09	3,326.04
001-5-620-2-6241 CONTRIBUTIONS	<u>19,998.00</u>	<u>0.00</u>	<u>6,653.00</u>	<u>33.27</u>	<u>13,345.00</u>
TOTAL PERSONAL SERVICES	114,549.00	10,623.54	96,703.34	84.42	17,845.66

SERVICES AND COMMODITIES

001-5-620-2-6331 VEHICLE FUEL-OIL-LUBRICANTS	100.00	0.00	0.00	0.00	100.00
001-5-620-2-6332 VEHICLE & EQUIP MAINTENANCE	100.00	0.00	0.00	0.00	100.00
001-5-620-2-6371 UTILITIES-ELEC,GAS-SANITATION	9,000.00	329.26	6,054.23	67.27	2,945.77
001-5-620-2-6373 TELEPHONE/RADIO	4,700.00	307.19	5,462.64	116.23 (	762.64)
001-5-620-2-6402 ADVERTISING & LEGAL PUBLICATIO	9,000.00	921.46	10,091.82	112.13 (	1,091.82)
001-5-620-2-6405 COURT & RECORDING FEES	150.00	0.00	27.00	18.00	123.00
001-5-620-2-6407 PROFESS FEES-DRS, LAWYERS, ENG	90,000.00	3,265.43	57,617.52	64.02	32,382.48
001-5-620-2-6409 INSURANCE - PROPERTY	11,136.00	0.00	3,711.69	33.33	7,424.31
001-5-620-2-6419 DATA PROCESSING EXPENSES	10,840.00	224.77	6,064.32	55.94	4,775.68
001-5-620-2-6420 ELECTION FEES	2,500.00	0.00	2,867.63	114.71 (	367.63)
001-5-620-2-6426 BUILDING & GROUNDS MAINTENANCE	12,000.00	752.04	10,075.98	83.97	1,924.02
001-5-620-2-6432 SERVICE/MAINT AGREEMENTS	9,500.00	1,795.10	10,438.85	109.88 (	938.85)
001-5-620-2-6437 CODIFICATION/MAPS/ZONING UPDAT	3,500.00	0.00	2,589.00	73.97	911.00
001-5-620-2-6438 SPECIAL PROGRAMS (MAIN STREET)	23,000.00	14.02	14,177.04	61.64	8,822.96
001-5-620-2-6439 ECONOMIC DEVELOPMENT	10,000.00	0.00	1,748.00	17.48	8,252.00
001-5-620-2-6440 REFUNDS	1,000.00	0.00	5,506.50	550.65 (	4,506.50)
001-5-620-2-6490 OTHER PROF SERVICES (TIF)	40,000.00	0.00	35,807.50	89.52	4,192.50
001-5-620-2-6506 OFFICE SUPPLIES	4,500.00	25.47	2,131.84	47.37	2,368.16
001-5-620-2-6508 POSTAGE AND SHIPPING	1,000.00	0.00	323.52	32.35	676.48
001-5-620-2-6525 HISTORICAL COMMISSION EXPENSE	26,000.00	410.00	23,114.29	88.90	2,885.71
001-5-620-2-6598 PETTY CASH & MISCELLANEOUS	5,000.00	3,000.91	36,527.48	730.55 (	31,527.48)
001-5-620-2-6601 Nile Kinnick Museum Fund	<u>0.00</u>	<u>(3,000.00)</u>	<u>0.00</u>	<u>0.00</u>	<u>0.00</u>
TOTAL SERVICES AND COMMODITIES	273,026.00	8,045.65	234,336.85	85.83	38,689.15

CAPITAL OUTLAY

001-5-620-3-6713 CAPITAL OUTLAY-BUILDING	<u>60,500.00</u>	<u>59,834.93</u>	<u>60,537.70</u>	<u>100.06 (</u>	<u>37.70)</u>
TOTAL CAPITAL OUTLAY	60,500.00	59,834.93	60,537.70	100.06 (	37.70)

TOTAL Finance	448,075.00	78,504.12	391,577.89	87.39	56,497.11
---------------	------------	-----------	------------	-------	-----------

CITY OF ADEL  
 EXPENDITURES REPORT (UNAUDITED)  
 AS OF: JUNE 30TH, 2024

001-GENERAL FUND

100.00% OF YEAR COMP.

Zoning/Compliance/Permits

DEPARTMENTAL EXPENDITURES	CURRENT BUDGET	CURRENT PERIOD	YEAR TO DATE ACTUAL	% OF BUDGET	BUDGET BALANCE
---------------------------	----------------	----------------	---------------------	-------------	----------------

PERSONAL SERVICES

001-5-630-1-6010 FULL TIME WAGES	79,054.00	3,839.24	47,052.64	59.52	32,001.36
001-5-630-1-6210 DUES, MEMBERSHIPS, SUBSCRIPTIO	400.00	0.00	75.00	18.75	325.00
001-5-630-1-6230 EDUCATION & TRAINING	1,000.00	0.00	335.00	33.50	665.00
001-5-630-1-6240 MEETING AND TRAVEL	<u>200.00</u>	<u>0.00</u>	<u>466.61</u>	<u>233.31</u>	<u>(266.61)</u>
TOTAL PERSONAL SERVICES	80,654.00	3,839.24	47,929.25	59.43	32,724.75

SERVICES AND COMMODITIES

001-5-630-2-6331 VEHICLE FUEL-OIL-LUBRICANTS	1,500.00	75.01	1,338.20	89.21	161.80
001-5-630-2-6332 VEHICLE, EQUIP & RADIO MAINT.	1,000.00	0.00	35.00	3.50	965.00
001-5-630-2-6373 TELEPHONE/RADIO	2,200.00	175.34	2,905.94	132.09	(705.94)
001-5-630-2-6402 ADVERTISING & LEGAL PUBLICATIO	1,400.00	44.80	2,778.59	198.47	(1,378.59)
001-5-630-2-6407 PROFESS FEES-DRS, LAWYERS, ENG	150,000.00	2,998.18	99,610.20	66.41	50,389.80
001-5-630-2-6408 INSURANCE-FIRE & AUTO-GENERAL	2,941.00	0.00	979.68	33.31	1,961.32
001-5-630-2-6419 DATA PROCESSING	1,200.00	23.00	663.50	55.29	536.50
001-5-630-2-6426 BUILDING & GROUNDS MAINTENANCE	0.00	0.00	1,727.57	0.00	(1,727.57)
001-5-630-2-6432 SERVICE & MAINT AGREEMENTS	3,000.00	259.71	4,420.40	147.35	(1,420.40)
001-5-630-2-6506 OFFICE SUPPLIES	1,500.00	125.89	2,120.44	141.36	(620.44)
001-5-630-2-6599 MISC SUPPLIES	<u>500.00</u>	<u>0.00</u>	<u>0.00</u>	<u>0.00</u>	<u>500.00</u>
TOTAL SERVICES AND COMMODITIES	165,241.00	3,701.93	116,579.52	70.55	48,661.48

CAPITAL OUTLAY

TOTAL Zoning/Compliance/Permits	245,895.00	7,541.17	164,508.77	66.90	81,386.23
---------------------------------	------------	----------	------------	-------	-----------

CITY OF ADEL  
EXPENDITURES REPORT (UNAUDITED)  
AS OF: JUNE 30TH, 2024

001-GENERAL FUND

100.00% OF YEAR COMP.

Internet

DEPARTMENTAL EXPENDITURES	CURRENT BUDGET	CURRENT PERIOD	YEAR TO DATE ACTUAL	% OF BUDGET	BUDGET BALANCE
<u>SERVICES AND COMMODITIES</u>					
TOTAL EXPENDITURES	3,908,186.00	424,758.12	3,518,827.53	90.04	389,358.47

110-ROAD USE TAX 100.00% OF YEAR COMP.

DEPARTMENTAL EXPENDITURES	CURRENT BUDGET	CURRENT PERIOD	YEAR TO DATE ACTUAL	% OF BUDGET	BUDGET BALANCE
<u>PERSONAL SERVICES</u>					
110-5-210-1-6010 FULL TIME WAGES	242,899.00	19,501.64	228,310.33	93.99	14,588.67
110-5-210-1-6011 MAYOR & COUNCIL WAGES	3,300.00	0.00	3,300.00	100.00	0.00
110-5-210-1-6020 PART TIME WAGES	1,430.00	0.00	1,719.98	120.28 (	289.98)
110-5-210-1-6040 OVERTIME WAGES	2,500.00	0.00	630.64	25.23	1,869.36
110-5-210-1-6110 CITY'S CONTRIBUTION FICA	0.00	1,411.25	2,843.44	0.00 (	2,843.44)
110-5-210-1-6120 CITY'S CONTRIBUTION-IPERS	23,207.00	1,840.96	22,478.54	96.86	728.46
110-5-210-1-6147 FLEX PLAN TPA	67.00	0.00	44.89	67.00	22.11
110-5-210-1-6150 MEDICAL INSURANCE	54,131.00	4,398.30	48,904.92	90.35	5,226.08
110-5-210-1-6210 DUES, MEMBERSHIPS, SUBSCRIPTIO	4,000.00	0.00	4,501.48	112.54 (	501.48)
110-5-210-1-6230 EDUCATION & TRAINING	2,000.00	0.00	1,380.00	69.00	620.00
110-5-210-1-6240 MEETINGS AND TRAVEL	<u>1,000.00</u>	<u>0.00</u>	<u>12.00</u>	<u>1.20</u>	<u>988.00</u>
TOTAL PERSONAL SERVICES	334,534.00	27,152.15	314,126.22	93.90	20,407.78
<u>SERVICES AND COMMODITIES</u>					
110-5-210-2-6331 VEHICLE FUEL-OIL-LUBRICANTS	15,000.00	1,521.31	20,598.61	137.32 (	5,598.61)
110-5-210-2-6332 VEHICLE, EQUIP & RADIO MAINT.	15,000.00	774.28	22,394.19	149.29 (	7,394.19)
110-5-210-2-6371 UTILITIES-ELEC,GAS-SANITATION	11,500.00	259.55	6,512.68	56.63	4,987.32
110-5-210-2-6373 TELEPHONE/RADIO	1,800.00	114.97	3,125.86	173.66 (	1,325.86)
110-5-210-2-6402 ADVERTISING & LEGAL PUBLICATIO	300.00	0.00	0.00	0.00	300.00
110-5-210-2-6407 PROFESS FEES-DRS, LAWYERS, ENG	10,000.00	274.74	18,700.66	187.01 (	8,700.66)
110-5-210-2-6415 UNIFORM RENTAL	3,000.00	28.14	303.86	10.13	2,696.14
110-5-210-2-6417 STREET MAINT	80,000.00	9,660.63	77,653.15	97.07	2,346.85
110-5-210-2-6418 SIGNS	15,000.00	0.00	6,673.01	44.49	8,326.99
110-5-210-2-6419 DATA PROCESSING EXPENSES	2,069.00	35.00	2,373.96	114.74 (	304.96)
110-5-210-2-6425 TREE REMOVAL	5,000.00	1,420.11	4,946.51	98.93	53.49
110-5-210-2-6426 BUILDING & GROUNDS MAINTENANCE	20,000.00	113.54	9,327.48	46.64	10,672.52
110-5-210-2-6431 SNOW REMOVAL	55,000.00	12,162.00	31,530.88	57.33	23,469.12
110-5-210-2-6432 SERVICE & MAINT AGREEMENTS	6,000.00	343.07	7,407.94	123.47 (	1,407.94)
110-5-210-2-6501 CHEMICALS	1,000.00	0.00	251.82	25.18	748.18
110-5-210-2-6504 MINOR EQUIPMENT	3,000.00	0.00	3,456.61	115.22 (	456.61)
110-5-210-2-6506 OFFICE SUPPLIES	1,500.00	125.87	1,566.27	104.42 (	66.27)
110-5-210-2-6598 PETTY CASH & MISCELLANEOUS	100.00	0.00	0.00	0.00	100.00
110-5-210-2-6599 MISC SUPPLIES	<u>10,000.00</u>	<u>1,188.29</u>	<u>10,265.51</u>	<u>102.66 (</u>	<u>265.51)</u>
TOTAL SERVICES AND COMMODITIES	255,269.00	28,021.50	227,089.00	88.96	28,180.00
<u>CAPITAL OUTLAY</u>					
110-5-210-3-6711 CAPITAL OUTLAY-VEHICLE	149,300.00	0.00	144,860.98	97.03	4,439.02
110-5-210-3-6713 CAPITAL OUTLAY-BUILDING	<u>50,000.00</u>	<u>0.00</u>	<u>7,588.50</u>	<u>15.18</u>	<u>42,411.50</u>
TOTAL CAPITAL OUTLAY	199,300.00	0.00	152,449.48	76.49	46,850.52
<u>TRANSFERS</u>					
110-5-210-5-6911 TRANSFERS OUT	<u>359,323.00</u>	<u>328,323.00</u>	<u>359,323.00</u>	<u>100.00</u>	<u>0.00</u>
TOTAL TRANSFERS	359,323.00	328,323.00	359,323.00	100.00	0.00
<hr/>					
TOTAL Road Use Tax	1,148,426.00	383,496.65	1,052,987.70	91.69	95,438.30
<hr/>					
TOTAL EXPENDITURES	1,148,426.00	383,496.65	1,052,987.70	91.69	95,438.30
=====					

600-WATER UTILITY

100.00% OF YEAR COMP.

Water

DEPARTMENTAL EXPENDITURES	CURRENT BUDGET	CURRENT PERIOD	YEAR TO DATE ACTUAL	% OF BUDGET	BUDGET BALANCE
---------------------------	----------------	----------------	---------------------	-------------	----------------

PERSONAL SERVICES

600-5-810-1-6010 FULL TIME WAGES	334,460.00	26,075.49	290,211.34	86.77	44,248.66
600-5-810-1-6011 MAYOR & COUNCIL WAGES	4,950.00	0.00	4,950.00	100.00	0.00
600-5-810-1-6020 PART TIME WAGES	10,010.00	457.50	12,571.71	125.59 (	2,561.71)
600-5-810-1-6040 OVERTIME WAGES	10,500.00	1,576.62	13,590.94	129.44 (	3,090.94)
600-5-810-1-6110 CITY'S CONTRIBUTION FICA	26,592.00	2,053.46	23,678.11	89.04	2,913.89
600-5-810-1-6120 CITY'S CONTRIBUTION-IPERS	32,731.00	2,610.37	30,028.05	91.74	2,702.95
600-5-810-1-6146 FLEX PLAN TPA	98.00	44.80	115.90	118.27 (	17.90)
600-5-810-1-6148 HRA REIMBURSEMENT	17,175.00	2,326.21	16,522.09	96.20	652.91
600-5-810-1-6149 HRA PLAN TPA	231.00	16.08	209.56	90.72	21.44
600-5-810-1-6150 MEDICAL INSURANCE	58,813.00	4,798.14	53,350.84	90.71	5,462.16
600-5-810-1-6151 LIFE & DISABILITY INS.	2,726.00	189.21	2,252.22	82.62	473.78
600-5-810-1-6160 WORKMEN'S COMP	3,867.00	0.00	2,794.05	72.25	1,072.95
600-5-810-1-6210 DUES, MEMBERSHIPS, SUBSCRIPTIO	4,463.00	1,128.80	3,378.23	75.69	1,084.77
600-5-810-1-6230 EDUCATION & TRAINING	4,052.00	202.29	6,193.47	152.85 (	2,141.47)
600-5-810-1-6240 MEETING & TRAVEL	<u>1,575.00</u>	<u>0.00</u>	<u>346.96</u>	<u>22.03</u>	<u>1,228.04</u>
TOTAL PERSONAL SERVICES	512,243.00	41,478.97	460,193.47	89.84	52,049.53

SERVICES AND COMMODITIES

600-5-810-2-6331 VEHICLE FUEL-OIL-LUBRICANTS	6,300.00	381.86	10,915.68	173.26 (	4,615.68)
600-5-810-2-6332 VEHICLE, EQUIP & RADIO MAINT.	4,255.00	0.00	2,547.86	59.88	1,707.14
600-5-810-2-6371 UTILITIES-ELEC,GAS-SANITATION	90,000.00	4,901.20	70,496.87	78.33	19,503.13
600-5-810-2-6373 TELEPHONE/RADIO	5,000.00	414.53	5,269.48	105.39 (	269.48)
600-5-810-2-6398 USDA #3 SHORT-LIVED ASSET RES	0.00	0.00	17,085.33	0.00 (	17,085.33)
600-5-810-2-6402 ADVERTISING & LEGAL PUBLICATIO	3,675.00	285.00	3,583.53	97.51	91.47
600-5-810-2-6407 PROFESS FEES-DRS, LAWYERS, ENG	30,000.00	65.75	57,772.49	192.57 (	27,772.49)
600-5-810-2-6408 INSURANCE-FIRE & AUTO-GENERAL	93,926.00	0.00	31,308.27	33.33	62,617.73
600-5-810-2-6415 UNIFORM RENTAL	2,200.00	28.14	303.86	13.81	1,896.14
600-5-810-2-6419 DATA PROCESSING EXPENSES	12,911.00	118.66	4,406.48	34.13	8,504.52
600-5-810-2-6420 WET TAX	115,000.00	8,825.42	110,523.75	96.11	4,476.25
600-5-810-2-6426 BUILDING & GROUNDS MAINTENANCE	9,390.00	306.03	4,874.63	51.91	4,515.37
600-5-810-2-6427 WELLS MAINT	30,000.00	2,975.75	5,075.85	16.92	24,924.15
600-5-810-2-6428 PLANT MAINTENANCE	25,000.00 (	593.74)	14,392.57	57.57	10,607.43
600-5-810-2-6429 DISTRIBUTION/ LINE MAINT	40,000.00	1,227.66	36,731.94	91.83	3,268.06
600-5-810-2-6432 SERVICE/MAINT AGREEMENTS	34,650.00	2,105.81	61,293.17	176.89 (	26,643.17)
600-5-810-2-6433 TESTING	21,000.00	1,127.32	13,848.42	65.94	7,151.58
600-5-810-2-6440 REFUNDS	200.00	0.00	0.00	0.00	200.00
600-5-810-2-6501 CHEMICALS	47,250.00	10,097.49	31,491.82	66.65	15,758.18
600-5-810-2-6504 MINOR EQUIPMENT	15,793.00	0.00	1,592.81	10.09	14,200.19
600-5-810-2-6506 OFFICE SUPPLIES	4,000.00	201.07	1,755.33	43.88	2,244.67
600-5-810-2-6511 PLANT SUPPLIES - METERS	31,500.00	41,040.00	101,562.81	322.42 (	70,062.81)
600-5-810-2-6599 MISC SUPPLIES	<u>14,347.00</u>	<u>818.17</u>	<u>4,377.98</u>	<u>30.51</u>	<u>9,969.02</u>
TOTAL SERVICES AND COMMODITIES	636,397.00	74,326.12	591,210.93	92.90	45,186.07

CITY OF ADEL  
 EXPENDITURES REPORT (UNAUDITED)  
 AS OF: JUNE 30TH, 2024

600-WATER UTILITY

100.00% OF YEAR COMP.

Water

DEPARTMENTAL EXPENDITURES	CURRENT BUDGET	CURRENT PERIOD	YEAR TO DATE ACTUAL	% OF BUDGET	BUDGET BALANCE
<u>CAPITAL OUTLAY</u>					
600-5-810-3-6711 CAPITAL OUTLAY-VEHICLE	19,000.00	29,648.70	41,042.68	216.01 (	22,042.68)
600-5-810-3-6713 CAPITAL OUTLAY-BUILDING	<u>60,000.00</u>	<u>0.00</u>	<u>0.00</u>	<u>0.00</u>	<u>60,000.00</u>
TOTAL CAPITAL OUTLAY	79,000.00	29,648.70	41,042.68	51.95	37,957.32
<u>DEBT SERVICE</u>					
600-5-810-4-6864 USDA #3 - PRINCIPAL	588,284.00	93,543.45	407,966.66	69.35	180,317.34
600-5-810-4-6865 USDA #3 - INTEREST	0.00	15,382.55	180,317.34	0.00 (	180,317.34)
600-5-810-4-6866 USDA #6 - PRINCIPAL	153,276.00	7,578.13	90,367.31	58.96	62,908.69
600-5-810-4-6867 USDA #6 - INTEREST	<u>0.00</u>	<u>5,194.87</u>	<u>62,908.69</u>	<u>0.00</u> (	<u>62,908.69</u> )
TOTAL DEBT SERVICE	741,560.00	121,699.00	741,560.00	100.00	0.00
<u>TRANSFERS</u>					
TOTAL Water	1,969,200.00	267,152.79	1,834,007.08	93.13	135,192.92
TOTAL EXPENDITURES	1,969,200.00	267,152.79	1,834,007.08	93.13	135,192.92

610-SEWER UTILITY FUND

100.00% OF YEAR COMP.

Sewer

DEPARTMENTAL EXPENDITURES	CURRENT BUDGET	CURRENT PERIOD	YEAR TO DATE ACTUAL	% OF BUDGET	BUDGET BALANCE
<b>PERSONAL SERVICES</b>					
610-5-815-1-6010 FULL TIME WAGES	369,969.00	30,419.84	331,591.72	89.63	38,377.28
610-5-815-1-6011 MAYOR & COUNCIL WAGES	4,950.00	0.00	4,950.00	100.00	0.00
610-5-815-1-6020 PART TIME WAGES	10,296.00	457.50	12,915.65	125.44 (	2,619.65)
610-5-815-1-6040 OVERTIME WAGES	10,000.00	0.00	2,546.99	25.47	7,453.01
610-5-815-1-6110 CITY'S CONTRIBUTION FICA	29,330.00	2,252.25	25,869.23	88.20	3,460.77
610-5-815-1-6120 CITY'S CONTRIBUTION-IPERS	36,110.00	2,871.63	32,924.23	91.18	3,185.77
610-5-815-1-6146 FLEX PLAN TPA	135.00	61.60	156.04	115.59 (	21.04)
610-5-815-1-6148 HRA REIMBURSEMENT	19,250.00	468.51	16,587.36	86.17	2,662.64
610-5-815-1-6149 HRA PLAN TPA	258.00	17.42	221.44	85.83	36.56
610-5-815-1-6150 MEDICAL INSURANCE	63,961.00	5,197.98	57,826.77	90.41	6,134.23
610-5-815-1-6151 LIFE & DISABILITY INS.	3,011.00	218.32	2,598.70	86.31	412.30
610-5-815-1-6160 WORKMEN'S COMP	3,831.00	0.00	2,794.05	72.93	1,036.95
610-5-815-1-6210 DUES, MEMBERSHIPS, SUBSCRIPTIO	5,250.00	0.00	3,073.48	58.54	2,176.52
610-5-815-1-6230 EDUCATION & TRAINING	3,675.00	0.00	3,147.62	85.65	527.38
610-5-815-1-6240 MEETING & TRAVEL	<u>1,824.00</u>	<u>0.00</u>	<u>784.03</u>	<u>42.98</u>	<u>1,039.97</u>
TOTAL PERSONAL SERVICES	561,850.00	41,965.05	497,987.31	88.63	63,862.69

**SERVICES AND COMMODITIES**

610-5-815-2-6331 VEHICLE FUEL-OIL-LUBRICANTS	6,300.00	394.74	10,170.46	161.44 (	3,870.46)
610-5-815-2-6332 VEHICLE, EQUIP & RADIO MAINT.	5,250.00	2,977.31	11,586.01	220.69 (	6,336.01)
610-5-815-2-6371 UTILITIES-ELEC,GAS-SANITATION	100,000.00	3,065.58	32,706.36	32.71	67,293.64
610-5-815-2-6373 TELEPHONE/RADIO	2,625.00	254.70	3,977.35	151.52 (	1,352.35)
610-5-815-2-6377 L.P. GAS	525.00	0.00	608.74	115.95 (	83.74)
610-5-815-2-6399 USDA #5 SHORT-LIVED ASSET RES	0.00	0.00	5,217.19	0.00 (	5,217.19)
610-5-815-2-6402 ADVERTISING & LEGAL PUBLICATIO	3,675.00	285.00	3,324.32	90.46	350.68
610-5-815-2-6407 PROFESS FEES-DRS, LAWYERS, ENG	10,000.00	3,882.50	24,702.64	247.03 (	14,702.64)
610-5-815-2-6408 INSURANCE-FIRE & AUTO-GENERAL	81,669.00	0.00	27,222.79	33.33	54,446.21
610-5-815-2-6415 UNIFORM RENTAL	2,200.00	28.14	303.86	13.81	1,896.14
610-5-815-2-6418 SALES TAX	10,000.00	0.00	10,000.67	100.01 (	0.67)
610-5-815-2-6419 DATA PROCESSING EXPENSES	12,386.00	1,514.12	5,543.01	44.75	6,842.99
610-5-815-2-6426 BUILDING & GROUNDS MAINTENANCE	7,875.00	178.97	10,319.92	131.05 (	2,444.92)
610-5-815-2-6428 PLANT MAINTENANCE	18,113.00	792.18	16,488.58	91.03	1,624.42
610-5-815-2-6429 DISTRIBUTION/ LINE MAINT	36,750.00	150.66	39,025.86	106.19 (	2,275.86)
610-5-815-2-6432 SERVICE/MAINT AGREEMENTS	52,500.00	21,330.49	59,284.72	112.92 (	6,784.72)
610-5-815-2-6433 TESTING	30,388.00	2,177.25	25,949.18	85.39	4,438.82
610-5-815-2-6501 CHEMICALS	0.00	0.00	579.41	0.00 (	579.41)
610-5-815-2-6504 MINOR EQUIPMENT	8,501.00	3,273.00	8,925.31	104.99 (	424.31)
610-5-815-2-6506 OFFICE SUPPLIES	1,575.00	163.47	2,513.85	159.61 (	938.85)
610-5-815-2-6511 PLANT SUPPLIES - METERS	30,388.00	0.00	43,247.42	142.32 (	12,859.42)
610-5-815-2-6599 MISC SUPPLIES	<u>8,820.00</u>	<u>2,073.99</u>	<u>9,829.30</u>	<u>111.44</u>	<u>(1,009.30)</u>
TOTAL SERVICES AND COMMODITIES	429,540.00	42,542.10	351,526.95	81.84	78,013.05

610-SEWER UTILITY FUND

100.00% OF YEAR COMP.

Sewer

DEPARTMENTAL EXPENDITURES	CURRENT BUDGET	CURRENT PERIOD	YEAR TO DATE ACTUAL	% OF BUDGET	BUDGET BALANCE
<u>CAPITAL OUTLAY</u>					
610-5-815-3-6711 CAPITAL OUTLAY-VEHICLE	15,300.00	0.00	11,393.98	74.47	3,906.02
610-5-815-3-6713 CAPITAL OUTLAY-BUILDING	10,790.00	4,580.00	4,580.00	42.45	6,210.00
610-5-815-3-6780 CAPITAL IMP-SEWER UPGRADE	<u>204,900.00</u>	<u>0.00</u>	<u>202,826.05</u>	<u>98.99</u>	<u>2,073.95</u>
TOTAL CAPITAL OUTLAY	230,990.00	4,580.00	218,800.03	94.72	12,189.97
<u>DEBT SERVICE</u>					
610-5-815-4-6862 USDA #1 - PRINCIPAL	42,288.00	1,796.61	21,363.11	50.52	20,924.89
610-5-815-4-6863 USDA #1 - INTEREST	0.00	( 6,478.57)	20,924.89	0.00	( 20,924.89)
610-5-815-4-6866 USDA #4 - PRINCIPAL	210,228.00	9,408.53	112,002.42	53.28	98,225.58
610-5-815-4-6867 USDA #4 - INTEREST	0.00	16,316.43	98,225.58	0.00	( 98,225.58)
610-5-815-4-6868 USDA #5 - PRINCIPAL	387,372.00	18,481.25	220,285.55	56.87	167,086.45
610-5-815-4-6869 USDA #5 - INTEREST	<u>0.00</u>	<u>13,799.75</u>	<u>167,086.45</u>	<u>0.00</u>	<u>( 167,086.45)</u>
TOTAL DEBT SERVICE	639,888.00	53,324.00	639,888.00	100.00	0.00
<u>TRANSFERS</u>					
610-5-815-5-6910 TRANSFERS OUT - SEWER	<u>5,972.00</u>	<u>0.00</u>	<u>7,299.38</u>	<u>122.23</u>	<u>( 1,327.38)</u>
TOTAL TRANSFERS	5,972.00	0.00	7,299.38	122.23	( 1,327.38)
<hr/>					
TOTAL Sewer	1,868,240.00	142,411.15	1,715,501.67	91.82	152,738.33
<hr/>					
TOTAL EXPENDITURES	<u>1,868,240.00</u>	<u>142,411.15</u>	<u>1,715,501.67</u>	<u>91.82</u>	<u>152,738.33</u>
	=====	=====	=====	=====	=====

615-STORM WATER UTILITY

100.00% OF YEAR COMP.

STORM WATER UTILITY

DEPARTMENTAL EXPENDITURES	CURRENT BUDGET	CURRENT PERIOD	YEAR TO DATE ACTUAL	% OF BUDGET	BUDGET BALANCE
---------------------------	----------------	----------------	---------------------	-------------	----------------

PERSONAL SERVICES

615-5-820-1-6010 FULL TIME WAGES	23,594.00	1,952.78	23,118.74	97.99	475.26
615-5-820-1-6011 MAYOR & COUNCIL WAGES	165.00	0.00	165.00	100.00	0.00
615-5-820-1-6020 PART TIME WAGES	286.00	0.00	343.97	120.27 (	57.97)
615-5-820-1-6110 CITY'S CONTRIBUTION FICA	1,835.00	141.05	1,719.19	93.69	115.81
615-5-820-1-6120 CITY'S CONTRIBUTION IPERS	2,262.00	184.32	2,173.50	96.09	88.50
615-5-820-1-6146 FLEX PLAN TPA	6.00	2.80	7.43	123.83 (	1.43)
615-5-820-1-6148 HRA REIMBURSEMENT	1,575.00	11.05	820.87	52.12	754.13
615-5-820-1-6149 HRA PLAN TPA	22.00	1.34	17.25	78.41	4.75
615-5-820-1-6150 MEDICAL AND DENTAL INSURANCE	5,753.00	399.84	4,445.90	77.28	1,307.10
615-5-820-1-6151 LIFE & DISABILITY INS	198.00	14.55	173.22	87.48	24.78
615-5-820-1-6160 WORK COMP INSURANCE	627.00	0.00	310.45	49.51	316.55
615-5-820-1-6210 DUES, MEMBERSHIPS & SUBSCRIPTI	3,150.00	0.00	3,073.48	97.57	76.52
615-5-820-1-6230 EDUCATION & TRAINING	<u>579.00</u>	<u>0.00</u>	<u>0.00</u>	<u>0.00</u>	<u>579.00</u>
TOTAL PERSONAL SERVICES	40,052.00	2,707.73	36,369.00	90.80	3,683.00

SERVICES AND COMMODITIES

615-5-820-2-6331 VEHICLE FUEL, OIL & LUBRICANTS	4,725.00	0.00	2,001.92	42.37	2,723.08
615-5-820-2-6332 VEHICLE EQUIP & RADIO MAINT	4,200.00	0.00	3,006.71	71.59	1,193.29
615-5-820-2-6373 TELEPHONE / RADIO	750.00	114.98	1,073.10	143.08 (	323.10)
615-5-820-2-6407 PROFESSIONAL FEES	10,500.00	0.00	2,278.65	21.70	8,221.35
615-5-820-2-6408 INSURANCE	2,436.00	0.00	811.58	33.32	1,624.42
615-5-820-2-6417 STREET SWEEPING	5,106.00	426.95	1,527.02	29.91	3,578.98
615-5-820-2-6419 DATA PROCESSING EXPENSES	4,725.00	0.00	1,181.66	25.01	3,543.34
615-5-820-2-6426 BUILDING & GROUNDS MAINTENANCE	525.00	6.03	6.03	1.15	518.97
615-5-820-2-6429 LINE MAINTENANCE	10,500.00	585.00	6,247.93	59.50	4,252.07
615-5-820-2-6432 SERVICE & MAINT AGREEMENTS	17,850.00	1,000.00	11,286.50	63.23	6,563.50
615-5-820-2-6501 CHEMICALS	525.00	0.00	0.00	0.00	525.00
615-5-820-2-6504 MINOR EQUIPMENT	3,159.00	0.00	0.00	0.00	3,159.00
615-5-820-2-6506 OFFICE SUPPLIES	525.00	37.60	37.60	7.16	487.40
615-5-820-2-6511 SWU INTAKE REPAIRS	21,000.00	0.00	15,997.00	76.18	5,003.00
615-5-820-2-6599 MISCELLANEOUS	<u>8,659.00</u>	<u>250.06</u>	<u>422.13</u>	<u>4.88</u>	<u>8,236.87</u>
TOTAL SERVICES AND COMMODITIES	95,185.00	2,420.62	45,877.83	48.20	49,307.17

CAPITAL OUTLAY

615-5-820-3-6711 CAPITAL OUTLAY-VEHICLE/EQUIP	<u>23,650.00</u>	<u>0.00</u>	<u>11,393.98</u>	<u>48.18</u>	<u>12,256.02</u>
TOTAL CAPITAL OUTLAY	23,650.00	0.00	11,393.98	48.18	12,256.02

DEBT SERVICE

615-5-820-4-6803 USDA #2 - PRINCIPAL	118,920.00	61,944.93	89,007.81	74.85	29,912.19
615-5-820-4-6858 USDA #2 - INTEREST	<u>0.00</u>	<u>2,470.07</u>	<u>29,912.19</u>	<u>0.00</u> (	<u>29,912.19)</u>
TOTAL DEBT SERVICE	118,920.00	64,415.00	118,920.00	100.00	0.00

CITY OF ADEL  
EXPENDITURES REPORT (UNAUDITED)  
AS OF: JUNE 30TH, 2024

615-STORM WATER UTILITY

100.00% OF YEAR COMP.

STORM WATER UTILITY

DEPARTMENTAL EXPENDITURES

	CURRENT BUDGET	CURRENT PERIOD	YEAR TO DATE ACTUAL	% OF BUDGET	BUDGET BALANCE
<u>TRANSFERS</u>					
615-5-820-5-6910 TRANSFERS OUT - STORMWATER	0.00	114,000.00	114,000.00	0.00	( 114,000.00)
TOTAL TRANSFERS	0.00	114,000.00	114,000.00	0.00	( 114,000.00)
<hr/>					
TOTAL STORM WATER UTILITY	277,807.00	183,543.35	326,560.81	117.55	( 48,753.81)
<hr/>					
TOTAL EXPENDITURES	277,807.00	183,543.35	326,560.81	117.55	( 48,753.81)
	=====	=====	=====	=====	=====

VENDOR NAME	DATE	DESCRIPTION	FUND	DEPARTMENT	AMOUNT_
Adel Auto Parts	7/09/24	FD- DEF FOR #104	GENERAL FUND	Fire Department	15.77_
				TOTAL:	15.77
Ahlers & Cooney, P.C.	7/09/24	PROF SERV- HANDBK PERSONNE	GENERAL FUND	Finance	810.00
	7/09/24	PROF SERV- HANDBK PERSONNE	GENERAL FUND	Finance	690.00_
				TOTAL:	1,500.00
Amazon	7/09/24	LIB PROG & SUPPLIES	GENERAL FUND	Library	279.21
	7/09/24	LIB PROG & SUPPLIES	GENERAL FUND	Library	920.56_
				TOTAL:	1,199.77
Crexendo	7/09/24	PHONE SYS	GENERAL FUND	Library	221.51_
				TOTAL:	221.51
Culligan	7/09/24	WATER COOLER	GENERAL FUND	Library	39.89_
				TOTAL:	39.89
Dallas County Data	7/09/24	SEWER- JUL1-JUL31 INT SERV	SEWER UTILITY FUND	Sewer	109.99_
				TOTAL:	109.99
Envisionware	7/09/24	PRINT MANAGEMENT SOFTWARE	GENERAL FUND	Library	1,044.75_
				TOTAL:	1,044.75
House Works	7/09/24	JANITORIAL	GENERAL FUND	Library	1,240.00_
				TOTAL:	1,240.00
ISU Extension-Dallas County	7/09/24	STORYBOOK	GENERAL FUND	Library	32.00_
				TOTAL:	32.00
Ingram Library Services	7/09/24	BOOKS	GENERAL FUND	Library	1,540.37_
				TOTAL:	1,540.37
Kanopy Inc	7/09/24	E-MOVIES	GENERAL FUND	Library	46.00_
				TOTAL:	46.00
Manatts Inc.	7/09/24	CONCRETE- STREET REPAIRS	ROAD USE TAX	Road Use Tax	534.00_
				TOTAL:	534.00
McCalley Tech Services	7/09/24	PRIRCH SOFTWARE INSTALL	GENERAL FUND	Library	500.00
	7/09/24	NEW SERVER BATTERY BACK UP	TRUST AND AGENCY	Library	880.00_
				TOTAL:	1,380.00
Ray Hemphill	7/09/24	PD- FLOOD BARRIER STORAGE	GENERAL FUND	Police Department	150.00_
				TOTAL:	150.00
THE IOWAN	7/09/24	MAGAZINE	GENERAL FUND	Library	24.00_
				TOTAL:	24.00
Verizon Wireless	7/09/24	FD- IPAD DATA	GENERAL FUND	Fire Department	160.04_
				TOTAL:	160.04
				TOTAL:	0.00



SELECTION CRITERIA

-----  
SELECTION OPTIONS

VENDOR SET: 01-ADEL  
VENDOR: All  
CLASSIFICATION: All  
BANK CODE: All  
ITEM DATE: 7/08/2024 THRU 7/09/2024  
ITEM AMOUNT: 99,999,999.00CR THRU 99,999,999.00  
GL POST DATE: 0/00/0000 THRU 99/99/9999  
CHECK DATE: 0/00/0000 THRU 99/99/9999

-----  
PAYROLL SELECTION

PAYROLL EXPENSES: YES  
EXPENSE TYPE: GROSS  
CHECK DATE: 7/08/2024 THRU 7/09/2024

-----  
PRINT OPTIONS

PRINT DATE: Item Date  
SEQUENCE: By Vendor Name  
DESCRIPTION: Distribution  
GL ACCTS: NO  
REPORT TITLE: C O U N C I L R E P O R T  
SIGNATURE LINES: 0

-----  
PACKET OPTIONS

INCLUDE REFUNDS: YES  
INCLUDE OPEN ITEM: YES  
-----



# Activities Department

Rod Wiebers, Director | 801 Nile Kinnick Drive South, Adel, IA 50003 | Phone: (515) 993-4819 | Email: [rod.wiebers@admschools.org](mailto:rod.wiebers@admschools.org)  
Alex Schnebbe, Assistant Activities Director | Email: [alex.schnebbe@admschools.org](mailto:alex.schnebbe@admschools.org)

To Whom It May Concern:

ADM Schools is requesting to use fireworks on the following dates and times as part of the ADM Tiger Varsity Football game. The fireworks used would be similar to what has been used during the past ADM football season.

Below is the schedule of dates and approximates time the fireworks would be used:

- Friday, August 30th at 7:00 PM
- Friday, September 6th at 7:00 PM
- Friday, September 27th at 7:00 PM
- Friday, October 4th at 7:00 PM
- Friday, October 18th at 7:00 PM

ADM will be using a "firework" boom at the beginning of each game and after each touchdown scored by ADM. If approved, we would work proactively to get information out to the community via social media and parents through our school messaging systems so people can be aware of the fireworks each Friday night and know it is coming.

We want to start communicating with the public ASAP and would appreciate an expedited response on this matter if possible. Thank you for your consideration of this request.

Sincerely,

A handwritten signature in black ink, appearing to read 'Rod Wiebers', written over a white background.

Rod Wiebers  
Activities Director  
ADM Schools





# State of Iowa

Alcoholic Beverages Division

## Applicant

NAME OF LEGAL ENTITY	NAME OF BUSINESS(DBA)	BUSINESS		
FAMILY DOLLAR STORES OF IOWA, LLC	FAMILY DOLLAR 25428	(757) 321-5000		
ADDRESS OF PREMISES	PREMISES SUITE/APT NUMBER	CITY	COUNTY	ZIP
712 Cottage Street		Adel	Dallas	50003
MAILING ADDRESS	CITY	STATE	ZIP	
500 Volvo ParkwayGreenbrier East	Chesapeake	Virginia	23320	

## Contact Person

NAME	PHONE	EMAIL
FAMILY DOLLAR	(757) 321-5000	ab-licensing@dollartree.com

## License Information

LICENSE NUMBER	LICENSE/PERMIT TYPE	TERM	STATUS
LG0000787	Class B Retail Alcohol License	12 Month	Submitted to Local Authority

TENTATIVE EFFECTIVE DATE	TENTATIVE EXPIRATION DATE	LAST DAY OF BUSINESS
Aug 9, 2024	Aug 8, 2025	

### SUB-PERMITS

Class B Retail Alcohol License



## PRIVILEGES

## Status of Business

## BUSINESS TYPE

Limited Liability Company

## Ownership

- Individual Owners

NAME	CITY	STATE	ZIP	POSITION	% OF OWNERSHIP	U.S. CITIZEN
John Mitchell	Chesapeake	Virginia	23320	SECRETARY	0.00	Yes
Jonathan Elder	Chesapeake	Virginia	23320	VICE PRESIDENT	0.00	Yes
Peter Barnett	Chesapeake	Virginia	23320	PRESIDENT	0.00	Yes
Harry Rashad Spencer	Chesapeake	Virginia	23320	ASSISTANT SECRETARY	0.00	Yes
Todd Littler	Chesapeake	Virginia	23320	SENIOR VICE PRESIDENT	0.00	Yes

## Insurance Company Information

INSURANCE COMPANY

POLICY EFFECTIVE DATE

POLICY EXPIRATION DATE

DRAM CANCEL DATE

OUTDOOR SERVICE EFFECTIVE DATE

OUTDOOR SERVICE EXPIRATION DATE



# State of Iowa

Alcoholic Beverages Division

BOND EFFECTIVE DATE

TEMP TRANSFER EFFECTIVE  
DATE

TEMP TRANSFER EXPIRATION  
DATE

**Additional instructions are on the final page.**

For period (MM/DD/YYYY) 07 / 01 / 2024 through 06/30/2025

Use this form to apply for a retail permit to sell cigarettes, tobacco, alternative nicotine, or vapor products at retail. If you need a different, non-retail cigarette or tobacco permit, use form 70-015. If approved, the permit is only valid for the location listed on the permit. You must obtain a separate retail permit for each location you own or operate.

**Business Information:**

Legal name/Doing business as (DBA): CIV Plus Adel

Iowa sales and use tax account number: 93-2974061

Retail address: 700 Common Place, Ste 200 City: Adel State: IA ZIP: 50003

Mailing address: 11338 Aurora Ave Bldg 10 City: Urbandale State: IA ZIP: 50322

Phone: 515-255-0004

**Legal Ownership Information:**

Type of ownership: Sole Proprietor  Partnership  Corporation  LLC  LLP

Name of sole proprietor, partnership, corporation, LLC, or LLP: Central Iowa Vapors LLC

Primary office address: 11338 Aurora Ave Bldg 10 City: Urbandale State: IA ZIP: 50322

Phone: 515-255-0004 Fax: \_\_\_\_\_ Email: statereporting@gstdis.com

**Retail Information:**

Types of Sales: Over-the-counter  Vending machine  Vending machine that assembles cigarettes  Delivery sales of alternative nicotine/vapor products (see instructions)  Mobile sales (see instructions)  VIN: \_\_\_\_\_ License plate number: \_\_\_\_\_

Types of Products Sold: (Check all that apply)

Cigarettes  Tobacco  Alternative nicotine products  Vapor products

**Type of Establishment: (Select the options that best describe the establishment)**

Alternative nicotine/vapor store  Bar  Convenience store/gas station  Drug store   
Grocery store  Hotel/motel  Liquor store  Restaurant  Tobacco store   
Other (provide description)  \_\_\_\_\_

Do you have other permits issued under Iowa Code chapter 453A? If yes, provide permit number(s):  
\_\_\_\_\_

Include with this application a list of your suppliers and customers on a separate sheet.

**Identify partners or corporate officers if the business is not a sole proprietorship.**

Name: Corey Halfhill Title: President

Address: 16008 Tanglewood Dr

City: Urbandale State: Iowa ZIP: 50323

Name: \_\_\_\_\_ Title: \_\_\_\_\_

Address: \_\_\_\_\_

City: \_\_\_\_\_ State: \_\_\_\_\_ ZIP: \_\_\_\_\_

Iowa Retail Permit Application for Cigarette/Tobacco/Nicotine/Vapor, page 2

Name: \_\_\_\_\_ Title: \_\_\_\_\_

Address: \_\_\_\_\_

City: \_\_\_\_\_ State: \_\_\_\_\_ ZIP: \_\_\_\_\_

If this application is approved and a permit is granted, I/we do hereby bind ourselves to a faithful observance of the laws governing the sale of cigarettes, tobacco, alternative nicotine, and vapor products. I declare under penalties of perjury or false certificate, that I have examined this application, and to the best of my knowledge and belief, it is true, correct, and complete.

Signature of Owner(s), Partner(s), or Corporate Official(s)

Printed name: Corey Halfhill

Printed name: Tristan Pascoe

Signature: [Handwritten Signature]

Signature: Tristan Pascoe

Date: 6/10/2024

Date: 6/10/2024

Printed name: \_\_\_\_\_

Signature: \_\_\_\_\_

Date: \_\_\_\_\_

Send this completed application and the applicable fee to your local jurisdiction. If your local jurisdiction permits electronic transmission of this application, your email or fax signature will constitute a valid signature. It is up to your local jurisdiction to approve this application and issue the permit. You must have an approved permit issued to you by the local jurisdiction before acting as a retailer in that jurisdiction. You must separately apply in each local jurisdiction in which you plan to act as a retailer. If you have any questions about the status of your application, contact your city clerk (within city limits) or your county auditor (outside city limits). NOTE: A completed application is NOT a valid permit even if submitted to your local jurisdiction with the applicable fee.

FOR CITY CLERK/COUNTY AUDITOR ONLY – MUST BE COMPLETE

- Fill in the amount paid for the permit: \$75.00
- Fill in the date the permit was approved 06/26/2024 by the council or board: ratified by Council on 07/09/2024
- Fill in the permit number issued by the city/county: FY2025-007
- Fill in the name of the city or county issuing the permit: City of Adel
- New  Renewal

Send completed/approved application to the Iowa Department of Revenue within 30 days of issuance. Make sure the information on the application is complete and accurate. A copy of the permit does not need to be sent; only the application is required. If a permit is being exchanged due to change of location within the same jurisdiction, permittee should complete an application with new location information and application should be sent to the Department as described above. Permittees who exchange a valid permit are not required to pay an additional fee when an exchange application is submitted. It is preferred that applications are sent via email, as this allows for a receipt confirmation to be sent to the local authority.

- Email: [iapledge@iowaabd.com](mailto:iapledge@iowaabd.com)
- Fax: 515-281-7375

**RESOLUTION NO. 24-39**

**RESOLUTION TEMPORARILY CLOSING PUBLIC WAYS OR GROUNDS IN  
CONNECTION WITH A SPECIAL EVENT KNOWN AS  
2024 LOCUST STREET BLOCK PARTY**

WHEREAS, Iowa Code Section 364.12(2) states "a city shall keep all public grounds, streets, sidewalks, alleys, bridges, culverts, overpasses, underpasses, grade crossing separations and approaches, public ways, squares, and commons open, in repair and free from nuisance;" and

WHEREAS, Iowa Code Section 364.12(2)(a) states "public ways and grounds may be temporarily closed by resolution;" and

WHEREAS, Jessica Weil, of 501 N 15<sup>th</sup> St, has requested closure of the following street from 4:00 p.m. to 10:00 p.m. on the date(s) listed below, in conjunction with the special event known as 2024 Locust Street Block Party.

Saturday July 27, 2024  
4:00 p.m. – 10:00 p.m.  
The intersection of 15<sup>th</sup> Street and Locust St  
The intersection of 14<sup>th</sup> Street and Locust St

NOW, THEREFORE, BE IT RESOLVED, pursuant to Iowa Code Section 364.12(2)(a), the City Council of the City of Adel, Iowa does hereby temporarily close the streets as stated above.

Passed and approved this 9<sup>th</sup> day of July, 2024.

\_\_\_\_\_  
James F. Peters, Mayor

ATTEST:

\_\_\_\_\_  
Carrie Erickson, City Clerk



**City of Adel**  
**Block Party and Street Closure Permit Application**

Event Name	Block Party
Date(s) of the Event	Saturday, July 27

**CONTACT INFORMATION**

Sponsor / Contact	Jessica Weil
Address	501 N 15 <sup>th</sup> St
City	Adel
State	Iowa
Zip Code	50003
Day Phone Number	<del>515</del> 515 205 4321
Cell Phone Number	same as above
Email Address	jweil324@gmail.com

**TIME OF EVENT**

Event Set-up Time	4 P
Event Start Time	5 P
Event End Time	10 P
Event Cleanup Time	after or next morning morning

**EVENT INFORMATION**

<b>Event Description</b> Please attach a map of the specific area to be used and the street(s) to be blocked off. Except in very limited circumstances, the City will require that a street closing be from cross intersection to cross intersection.	
<b>Estimated Attendance?</b>	30
<b>Will Alcohol be Served?</b> No alcohol may be kept or consumed on the street. It must be on private property.	YES <input checked="" type="radio"/> NO
<b>Will you be using amplified sound?</b> If yes, a sound permit application is required along with applicable fees.	<input checked="" type="radio"/> YES / NO
<b>Consent from residents?</b> 90% of the residents in the area, including any listing agent with a home for sale, must be in favor of and / or approve the request.	<input checked="" type="radio"/> YES / NO

**DEPOSIT: \$100.00** This deposit will be refunded if the block party area is fully cleaned up after the party and the barricades are returned in satisfactory condition.

**CONSENT FROM RESIDENTS**

*By signing below, I understand the Block Party and Street Closure Policy and that I have been informed of the event that is being applied for.*

NAME	ADDRESS	APPROVE / DISAPPROVE
Mary Snow	4414 Grove	<input checked="" type="checkbox"/> APPROVE / <input type="checkbox"/> DISAPPROVE
John McGlynn	1406 Grove	<input checked="" type="checkbox"/> APPROVE / <input type="checkbox"/> DISAPPROVE
Ron White	409 N 14th St.	<input checked="" type="checkbox"/> APPROVE / <input type="checkbox"/> DISAPPROVE
Susan McCann	419 N. 14th St	<input checked="" type="checkbox"/> APPROVE / <input type="checkbox"/> DISAPPROVE
Phillip Mathvssu	1404 Locust St	<input checked="" type="checkbox"/> APPROVE / <input type="checkbox"/> DISAPPROVE
Joe Hopper	1418 Locust	<input checked="" type="checkbox"/> APPROVE / <input type="checkbox"/> DISAPPROVE
Jay [unclear]	1515 Locust	<input checked="" type="checkbox"/> APPROVE / <input type="checkbox"/> DISAPPROVE
Jay Heefner	1512 Locust	<input checked="" type="checkbox"/> APPROVE / <input type="checkbox"/> DISAPPROVE
Renee & Kenny <sup>Davis</sup>	1407 Locust	<input checked="" type="checkbox"/> APPROVE / <input type="checkbox"/> DISAPPROVE
Janine [unclear]	503 North 14th St	<input checked="" type="checkbox"/> APPROVE / <input type="checkbox"/> DISAPPROVE
Brady Erlandson	513 N 14th St	<input checked="" type="checkbox"/> APPROVE / <input type="checkbox"/> DISAPPROVE
Lacey Guite	515 N 14th St	<input checked="" type="checkbox"/> APPROVE / <input type="checkbox"/> DISAPPROVE
Lisa Brasse	526 14th	<input checked="" type="checkbox"/> APPROVE / <input type="checkbox"/> DISAPPROVE
Deann + Anita Vaco	729-1045	<input checked="" type="checkbox"/> APPROVE / <input type="checkbox"/> DISAPPROVE
Kelly Kape	412 N 15th St.	<input checked="" type="checkbox"/> APPROVE / <input type="checkbox"/> DISAPPROVE
		APPROVE / DISAPPROVE

**RETURN PERMIT APPLICATION:**

City of Adel  
 301 S. 10th Street  
 Adel, IA 50003

I hereby certify the above statements are true and correct, to the best of my knowledge, and that false statement(s) may be grounds for denial of the application. It is understood the activities at all times during the event shall comply with all applicable federal, state, county, and City laws and regulations. It is further understood that the individual, organization, association, and / or block party organizer will be responsible for any and all damages arising as a result of this event.

In accordance with the executed Indemnification and Hold Harmless Agreement, the applicant hereby waives any and all claims which the applicant may have as a result of this event against the City of Adel, Iowa, its officers, agents, employees, or board members.

I have been advised of policies and procedures for the conduct of a block party in the City of Adel and I, or the organization I represent, have met or will meet all requirements established by the City. Further, I understand that if all requirements are not met, the Block Party and Street Closure Permit may be canceled by the City at any time including at the start of or during the event. If this event is sponsored by an organization, I hereby certify I have the legal authority to represent the applicant and / or the participants, and I have read the requirements for issuance of the permit and the Hold Harmless Agreement, understand their provisions, and freely and voluntarily sign this application.

*Jessica Weil*  
*Jessica Weil* \_\_\_\_\_ *7-2-24*  
 Applicant Name Signature Date

FOR CITY USE ONLY			
DEPOSIT RECEIVED		YES / NO	
DEPOSIT TYPE		CASH / CHECK	
90% RESIDENT APPROVAL		YES / NO	
APPROVED: YES / NO		DATE OF APPROVAL:	
COPIES DISTRIBUTED TO CITY OFFICIALS: YES / NO		HOLD HARMLESS AGREEMENT: YES / NO	
RECEIVED BY	SIGNATURE	DATE	APPROVED?
Police Dept.			YES / NO
Fire Dept.			YES / NO
Public Works			YES / NO
City Administrator			YES / NO



## City of Adel Hold Harmless Agreement

**WHEREAS**, the City of Adel, Iowa (City) owns certain real property and public right-of-way which are under the direction and control of the Adel City Council.

**WHEREAS**, (the "Organization") desires to use and occupy certain property containing the facilities and grounds at, Locust (Location)

**WHEREAS**, the City is willing to grant to the Organization the right to use and occupy the location provided the City, its officers, employees and agents, (collectively called "City") are held harmless.

**NOW, THEREFORE, IN CONSIDERATION OF THE MUTUAL COVENANTS HEREIN CONTAINED**, the City and the Organization agree as follows:

1. The City hereby grants to the Organization the right to use and occupy the facilities and grounds identified above for a period commencing the July 27 day of July, 2024 and ending on the 27 day of July, 2024 for the purpose of the Organization activities.
2. To the extent permitted by law, the Organization shall defend, indemnify, and hold harmless the City from any and all claims, lawsuits, demands, causes of action, liability, loss, damage and/or injury, of any kind whatsoever (including without limitation all claims for monetary loss, property damage, equitable relief, personal injury and/or wrongful death), whether brought by an individual or other entity, or imposed by court of law or by administrative action of any federal, state, or local governmental body or agency, arising out of, in any way whatsoever, any acts, omission, negligence, or willful misconduct on the part of the Organization, its officers, owners, personnel, employees, agents, contractors, invitees, or volunteers. This indemnification applies to and includes, without limitation, the payment of all penalties, fines, judgments, awards, decrees, attorney fees, and related costs or expenses, and any reimbursements to the City for all legal fees, expenses, and cost incurred by it.
3. If any provision of this Agreement shall be held to be invalid or unenforceable for any reason, the remaining provisions shall continue to be valid and enforceable. If a court finds that any provision of this Agreement is invalid or unenforceable, but that by limiting such provision it would become valid and enforceable, then such provision shall be deemed to be written, construed, and enforced as so limited. The intent of the Parties is to provide as broad an indemnification as possible under Iowa law. In the event that any aspect of this Agreement is deemed unenforceable, the court is empowered to modify this Agreement to give the broadest possible interpretation permitted under Iowa law.
4. This Agreement shall be governed exclusively by the laws of Iowa, without regard to conflict of law provisions.
5. Any lawsuit or legal proceedings arising out of or relating to this Agreement in any way whatsoever shall be exclusively brought and litigated in federal and state courts of Iowa. Each Party expressly consents and submits to this exclusive jurisdiction and exclusive venue. Each Party expressly waives that right to challenge this jurisdiction and/or venue as improper

or inconvenient. Each Party consents to the dismissal of any lawsuit that they bring in any other jurisdiction or venue.

Words and phrases herein shall be construed as in the singular or plural number, and as masculine, feminine or neuter gender, according to context.

Dated this 2 day of July, 2024

By \_\_\_\_\_  
City Clerk

By Jessiah Weil  
Organization Representative

Locust Block Party

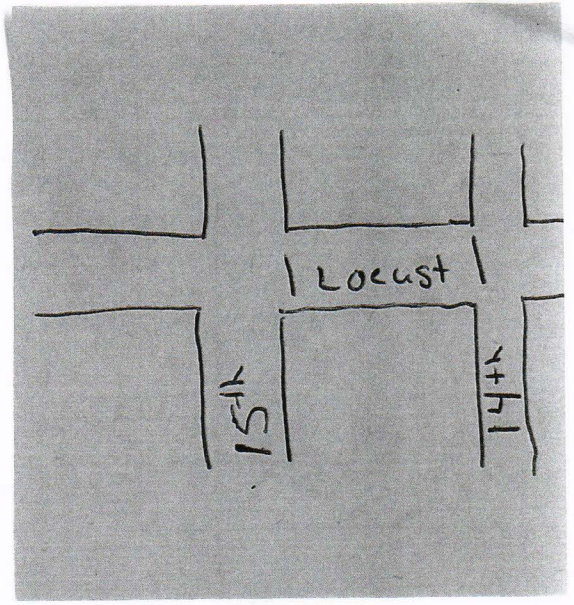

City of Adel  
Sound Permit Application

**For Special Events and the Amplification of Live  
Performances**



City of Adel  
Code Compliance Department  
301 South 10<sup>th</sup> Street  
Adel, IA 50003  
(515) 993-4525

[www.adeliowa.org](http://www.adeliowa.org)

A complete copy of the City of Adel Noise Ordinance (Ordinance No. 256) is available from the Code Compliance Department. The following is an excerpt from that ordinance as it pertains to the Sound Permit

43.08 NOISE PERMIT FOR SOUND EQUIPMENT.

No person shall use, operate or cause to be used or operated any sound equipment upon the public right-of-way, in any building or upon any public or private premises, if the sound emitted is plainly audible from the public right-of-way within the City, unless such person has obtained a noise permit in accordance with this section, and the actual use or operation of such sound equipment is not inconsistent with the statements made in the application, the conditions imposed in the sound equipment permit or the limitations specified in subsection 4 of this section. A noise permit shall not be transferable, and it shall be conspicuously displayed on or adjacent to the sound equipment.

1. Application for Permit. Applications for noise permits shall be made in writing to the City Clerk and shall contain the following information:

- A. Name, address, phone number(s) and signature of applicant.
- B. The purpose for which the sound equipment will be used.
- C. The location where the sound equipment will be used.
- D. The number of days of use and proposed hours of operation of the sound equipment.
- E. A general description of the sound equipment, including the license number of any motor vehicle upon which it is to be operated.
- F. Any other information as may be required by the City Clerk.

2. Permit Fee. The fees for a noise permit are as follows:

- A. Permits for 1 day or less \$50.00
- B. Permits for 2 through 7 days \$100.00

No fee is required for a noise permit issued to City, State or Federal government or any governmental subdivision or agency thereof.

3. Issuance of Permit. Permits may be issued by the City Clerk. Except as hereinafter provided, if the application contains the required information and is accompanied by the required fee, the noise permit for sound equipment shall be issued with reasonable dispatch. If the event requiring a noise permit has an ending time of 10:00 p.m. or later, the application must be approved by the Council prior to the permit being issued.

**Sound Permit Fees**  
24 hour event = \$50.00  
2-7 day event = \$100.00

**City of Adel**  
**Sound Permit**  
*For the Amplification of Sound Heard from  
the Public Right-Of-Way*

Permit applications received  
less than two (2) weeks  
before the event may not be  
processed by the City in  
time for the event.

Date: \_\_\_\_\_ Fee Received: \_\_\_\_\_ Permit No. \_\_\_\_\_

Is this for the amplification of a live performance? Y / N

Applicant's Name: Jessica Weil Phone No. 515-205-4321

Applicant's Address: 501 N 15<sup>th</sup> St

Have you, the applicant, ever been cited for a violation of the Adel Noise Ordinance? Y / N

If yes, explain: \_\_\_\_\_  
\_\_\_\_\_

Property owner's name: Jessica Weil

Property owner's address: 501 N 15<sup>th</sup> St

*I, the undersigned, hereby acknowledge and certify that I am the record fee title holder of the property for which this sound permit is requested, and I hereby consent to this application for a sound permit as described on this application.*

Jessica Weil 7-2-24  
Signature Date

Address of proposed activity: Locust - between 15<sup>th</sup> and 14<sup>th</sup>  
*Describe proposed activity, including times, dates, and number of people attending:*  
Block party - July 27  
\_\_\_\_\_  
\_\_\_\_\_

How will the parking for this event be handled?  
Side streets  
\_\_\_\_\_  
\_\_\_\_\_

**Attach an 8 ½ X 11 sketch plan of the proposed layout of the sound amplification equipment, including the orientation to and approximate distances from the adjoining properties.**

Have the adjoining property owners/residents been notified of the event for which this permit is requested?  Y  N

Addresses notified (attach additional sheets if necessary): \_\_\_\_\_  
\_\_\_\_\_

Describe what measures will be taken, if any, to minimize the effects of this performance on surrounding property:  
\_\_\_\_\_  
\_\_\_\_\_

APPLICANT'S CERTIFICATION - I hereby certify under penalty of perjury that the statements furnished including the drawing, present all information required for this application, and that the facts, statements and information presented are true and correct, and based upon my personal knowledge. I hereby acknowledge my obligation to comply with the City of Adel Municipal Code as it pertains to this activity and to obtain any and all necessary City, County, State and Federal permits, approvals and /or clearances, if applicable. Further, I hereby certify that I have read, understand and have received a copy of the conditions for the operation of the Sound Permit, and hereby agree to comply with such conditions. I also understand that should I fail to comply with the agreed upon conditions, my permit may be immediately revoked and that all other applicable penalties, including criminal prosecution may be pursued.

Jessica Weil  
Applicant's Signature

7-2-24  
Date

### Staff Use Only

#### Approval of Sound Permit

Approved by: \_\_\_\_\_

Date: \_\_\_\_\_

This sound permit is approved subject to the following exhibits and conditions:

Exhibits:

#### Denial of Sound Permit

Denied by: \_\_\_\_\_

Date: \_\_\_\_\_

This sound permit is denied based upon the following findings:

Findings:

- Copies of this permit to:
- Code Compliance
  - Police Dept.
  - Fire Dept.
  - Parks & Rec
  - Public Works

**CONSENT FROM RESIDENTS**

By signing below, I understand the Block Party and Street Closure Policy and that I have been informed of the event that is being applied for.

NAME	ADDRESS	APPROVE / DISAPPROVE
Mary Snow	414 Grove	APPROVE / DISAPPROVE
John McGee	1406 Grove	APPROVE / DISAPPROVE
Ron White	409 N 14th St.	APPROVE / DISAPPROVE
Susan McCann	419 N. 14th St	APPROVE / DISAPPROVE
Phillip Mathews	1404 Locust St	APPROVE / DISAPPROVE
Tom Hughes	1418 Locust	APPROVE / DISAPPROVE
Jay [unclear]	1515 Locust	APPROVE / DISAPPROVE
Jay Keefner	1512 Locust	APPROVE / DISAPPROVE
Renee & Kenny <sup>Davis</sup>	1407 Locust	APPROVE / DISAPPROVE
Jim King	503 North 14th St	APPROVE / DISAPPROVE
Brady Erlandson	513 N 14th St	APPROVE / DISAPPROVE
Lacey Guile	515 N 14th St	APPROVE / DISAPPROVE
Lisa Brasse	526 14th	APPROVE / DISAPPROVE
Debra + Anita Vaso	729-1045	APPROVE / DISAPPROVE
Kelly Pope	412 N 15th St.	APPROVE / DISAPPROVE
		APPROVE / DISAPPROVE

**RETURN PERMIT APPLICATION:**

City of Adel  
 301 S. 10th Street  
 Adel, IA 50003

**RESOLUTION NO. 24-40**

**RESOLUTION TEMPORARILY CLOSING PUBLIC WAYS OR GROUNDS IN  
CONNECTION WITH A SPECIAL EVENT KNOWN AS  
2024 SHELBY DRIVE BLOCK PARTY**

WHEREAS, Iowa Code Section 364.12(2) states "a city shall keep all public grounds, streets, sidewalks, alleys, bridges, culverts, overpasses, underpasses, grade crossing separations and approaches, public ways, squares, and commons open, in repair and free from nuisance;" and

WHEREAS, Iowa Code Section 364.12(2)(a) states "public ways and grounds may be temporarily closed by resolution;" and

WHEREAS, Maritza Elscott, of 1047 Shelby Drive, has requested closure of the following street from 4:00 p.m. to 11:00 p.m. on the date(s) listed below, in conjunction with the special event known as 2024 Shelby Drive Block Party.

Saturday August 17, 2024  
4:00 p.m. to 11:00 p.m.  
The corner of Bailey's Grove Dr and Shelby Dr  
The corner of Hunter Ct and Shelby Dr

NOW, THEREFORE, BE IT RESOLVED, pursuant to Iowa Code Section 364.12(2)(a), the City Council of the City of Adel, Iowa does hereby temporarily close the streets as stated above.

Passed and approved this 9<sup>th</sup> day of July, 2024.

\_\_\_\_\_  
James F. Peters, Mayor

ATTEST:

\_\_\_\_\_  
Carrie Erickson, City Clerk



## City of Adel Block Party and Street Closure Permit Application

<b>Event Name</b>	<del>Shelby</del> "Block Party"
<b>Date(s) of the Event</b>	August 17 <sup>th</sup> 2024

### CONTACT INFORMATION

<b>Sponsor / Contact</b>	Maritza Elscott
<b>Address</b>	1047 Shelby Drive
<b>City</b>	Adel
<b>State</b>	Iowa
<b>Zip Code</b>	50003
<b>Day Phone Number</b>	515-339-6499
<b>Cell Phone Number</b>	11
<b>Email Address</b>	Maritzamg87@gmail.com

### TIME OF EVENT

<b>Event Set-up Time</b>	8am - 1pm
<b>Event Start Time</b>	4pm
<b>Event End Time</b>	11pm
<b>Event Cleanup Time</b>	10 - 11pm

### EVENT INFORMATION

<p><b>Event Description</b> Please attach a map of the specific area to be used and the street(s) to be blocked off. Except in very limited circumstances, the City will require that a street closing be from cross intersection to cross intersection.</p>	<p><del>100 ppl</del> Couple water blow ups BBQ / pot luck Bags / corn hole</p>
<b>Estimated Attendance?</b>	100 ppl
<b>Will Alcohol be Served?</b> <i>No alcohol may be kept or consumed on the street. It must be on private property.</i>	YES / <input checked="" type="radio"/> NO
<b>Will you be using amplified sound?</b> <i>If yes, a sound permit application is required along with applicable fees.</i>	YES / <input checked="" type="radio"/> NO
<b>Consent from residents?</b> <i>90% of the residents in the area, including any listing agent with a home for sale, must be in favor of and / or approve the request.</i>	<input checked="" type="radio"/> YES / NO

**DEPOSIT: \$100.00** This deposit will be refunded if the block party area is fully cleaned up after the party and the barricades are returned in satisfactory condition.

**CONSENT FROM RESIDENTS**

*By signing below, I understand the Block Party and Street Closure Policy and that I have been informed of the event that is being applied for.*

NAME	ADDRESS	APPROVE / DISAPPROVE
KAREN WILSON	1051 Shelby Dr.	APPROVE / DISAPPROVE
Jamie Hachmeister	1052 Shelby Dr	APPROVE / DISAPPROVE
Evan Hammans	1044 Shelby Drive	APPROVE / DISAPPROVE
Austin Hennessey	1101 Shelby Dr	APPROVE / DISAPPROVE
Kelli Westendorf	1048 Shelby Dr	APPROVE / DISAPPROVE
		APPROVE / DISAPPROVE
		APPROVE / DISAPPROVE
		APPROVE / DISAPPROVE
		APPROVE / DISAPPROVE
		APPROVE / DISAPPROVE
		APPROVE / DISAPPROVE
		APPROVE / DISAPPROVE
		APPROVE / DISAPPROVE
		APPROVE / DISAPPROVE
		APPROVE / DISAPPROVE
		APPROVE / DISAPPROVE
		APPROVE / DISAPPROVE
		APPROVE / DISAPPROVE

**RETURN PERMIT APPLICATION:**

City of Adel  
 301 S. 10<sup>th</sup> Street  
 Adel, IA 50003



## City of Adel Hold Harmless Agreement

**WHEREAS**, the City of Adel, Iowa (City) owns certain real property and public right-of-way which are under the direction and control of the Adel City Council.

**WHEREAS**, (the "Organization") desires to use and occupy certain property containing the facilities and grounds at, Shelby Drive (Location)

**WHEREAS**, the City is willing to grant to the Organization the right to use and occupy the location provided the City, its officers, employees and agents, (collectively called "City") are held harmless.

**NOW, THEREFORE, IN CONSIDERATION OF THE MUTUAL COVENANTS HEREIN CONTAINED**, the City and the Organization agree as follows:

1. The City hereby grants to the Organization the right to use and occupy the facilities and grounds identified above for a period commencing the 17<sup>th</sup> day of August, 2024, and ending on the 17<sup>th</sup> day of August, 2024 for the purpose of the Organization activities.
2. To the extent permitted by law, the Organization shall defend, indemnify, and hold harmless the City from any and all claims, lawsuits, demands, causes of action, liability, loss, damage and/or injury, of any kind whatsoever (including without limitation all claims for monetary loss, property damage, equitable relief, personal injury and/or wrongful death), whether brought by an individual or other entity, or imposed by court of law or by administrative action of any federal, state, or local governmental body or agency, arising out of, in any way whatsoever, any acts, omission, negligence, or willful misconduct on the part of the Organization, its officers, owners, personnel, employees, agents, contractors, invitees, or volunteers. This indemnification applies to and includes, without limitation, the payment of all penalties, fines, judgments, awards, decrees, attorney fees, and related costs or expenses, and any reimbursements to the City for all legal fees, expenses, and cost incurred by it.
3. If any provision of this Agreement shall be held to be invalid or unenforceable for any reason, the remaining provisions shall continue to be valid and enforceable. If a court finds that any provision of this Agreement is invalid or unenforceable, but that by limiting such provision it would become valid and enforceable, then such provision shall be deemed to be written, construed, and enforced as so limited. The intent of the Parties is to provide as broad an indemnification as possible under Iowa law. In the event that any aspect of this Agreement is deemed unenforceable, the court is empowered to modify this Agreement to give the broadest possible interpretation permitted under Iowa law.
4. This Agreement shall be governed exclusively by the laws of Iowa, without regard to conflict of law provisions.
5. Any lawsuit or legal proceedings arising out of or relating to this Agreement in any way whatsoever shall be exclusively brought and litigated in federal and state courts of Iowa. Each Party expressly consents and submits to this exclusive jurisdiction and exclusive venue. Each Party expressly waives that right to challenge this jurisdiction and/or venue as improper

or inconvenient. Each Party consents to the dismissal of any lawsuit that they bring in any other jurisdiction or venue.

Words and phrases herein shall be construed as in the singular or plural number, and as masculine, feminine or neuter gender, according to context.

Dated this 25 day of August, 2024

By \_\_\_\_\_  
City Clerk

By [Signature]  
Organization Representative



# Super creative Maps

date / /





# McClure Engineering Co.

## Change Order Details

25-0035-604

---

<b>Description</b>	TAP-U-0035(604)--8I-25, Letting Date- March 19, 2024 In the City of Adel, a Rec Trail along Penoach St., S. 12th St., and south of Lynne Dr MEC#: 2022000190-000
<b>Prime Contractor</b>	ELDER CORPORATION 5088 EAST UNIVERSITY DES MOINES, IA 50327-7098
<b>Change Order</b>	1
<b>Status</b>	Pending
<b>Date Created</b>	06/14/2024
<b>Type</b>	Changed Conditions
<b>Summary</b>	Manhole Adjustment, Major
<b>Change Order Description</b>	After opening the manhole at the corner of Penoach and 15th, it was determined that the existing collar and cone were deteriorated beyond saving and needed to be replaced. This caused the adjustment to be greater than a Manhole Adjustment, Minor. Therefore, the Manhole Adjustment needed to be changed to a Manhole Adjustment, Major in order to replace the cone. After reviewing materials with their suppliers, Elder was able to provide a transition piece from the existing structure to a flat top manhole. Additional Documentation will be included on DocExpress. Add Item 8001, Manhole Adjustment, Major Reduce Item 0110, Manhole Adjustment, Minor by 1EA No changes in Working Days for this extra work.
<b>Awarded Project Amount</b>	\$1,124,000.00
<b>Authorized Project Amount</b>	\$1,124,000.00
<b>Change Order Amount</b>	\$2,958.00

**Revised Project Amount**      \$1,126,958.00

**Increases/Decreases**

Line Number	Item ID	Unit	Unit Price	Current		Change		Revised	
				Quantity	Amount	Quantity	Amount	Quantity	Amount
<b>Section: 0001 - TAP-U-0035(604)--8I-25, Trail Items</b>									
0110	2435-0600010	EACH	\$1,600.000	5.000	\$8,000.00	-1.000	-\$1,600.00	4.000	\$6,400.00
MANHOLE ADJUSTMENT, MINOR									
<b>Reason:</b> Contract Unit Price									
				<b>Funding Details</b>					
	25-0035-604-CAT-1	25-0035-604-CAT-1	25-0035-604	5.000	\$8,000.00	-1.000	-\$1,600.00	4.000	\$6,400.00
	25-0035-604-CAT-2	25-0035-604-CAT-2	25-0035-604	0.000	\$0.00	0.000	\$0.00	0.000	\$0.00
	25-0035-604-CAT-3 NON-PARTICIPATING			0.000	\$0.00	0.000	\$0.00	0.000	\$0.00
1 item	Totals				\$8,000.00		-\$1,600.00		\$6,400.00

**New Items**

Line Number	Item ID	Unit	Quantity	Unit Price	Extension
<b>Section: 0001 - TAP-U-0035(604)--8I-25, Trail Items</b>					
8001	2435-0600020	EACH	1.000	\$4,558.000	\$4,558.00
MANHOLE ADJUSTMENT, MAJOR:					

Line Number	Item ID	Unit	Quantity	Unit Price	Extension
-------------	---------	------	----------	------------	-----------

**Reason:** Price compares favorably to historic pricing in 2024. Price includes all costs associated with labor, material, equipment, and mobilization

**Funding Details**

25-0035-604-CAT-1	25-0035-604-CAT-1	25-0035-604	1.000	\$4,558.000	\$4,558.00
-------------------	-------------------	-------------	-------	-------------	------------

1 item	Total: \$4,558.00
--------	-------------------

### Funding Summary

Fund Package	Original Amount	Authorized Amount	Pending Change	Revised Amount
25-0035-604-CAT-1 25-0035-604-CAT-1 25-0035-604	\$822,468.00	\$822,468.00	\$2,958.00	\$825,426.00
25-0035-604-CAT-2 25-0035-604-CAT-2 25-0035-604	\$301,532.00	\$301,532.00	\$0.00	\$301,532.00
25-0035-604-CAT-3 NON-PARTICIPATING	\$0.00	\$0.00	\$0.00	\$0.00
3 fund packages	\$1,124,000.00	\$1,124,000.00	\$2,958.00	\$1,126,958.00

# Doc Express® Document Signing History

Contract: 25-0035-604 Document: CO 01

This document is in the process of being signed by all required signatories using the Doc Express® service. Following are the signatures that have occurred so far.

Date	Signed By
06/18/2024	Brent Thompson Elder Corporation Electronic Signature (Approved by Contractor)
06/20/2024	Brian Meyer McClure Engineering Co. Electronic Signature (Recommended by Engineer / Approved)
	(Approved by PIRC (when applicable))
	(Approved by Administering Bureau or designee)
	(Approved by FHWA (when applicable))

## Brian Meyer

---

**From:** Steve Frame <steve.frame@eldercorp.com>  
**Sent:** Tuesday, June 11, 2024 12:38 PM  
**To:** Brian Meyer  
**Subject:** RE: Adel Trail

Thank Brian

---

**From:** Brian Meyer <bmeyer@mcclurevision.com>  
**Sent:** Tuesday, June 11, 2024 12:22 PM  
**To:** Steve Frame <steve.frame@eldercorp.com>  
**Cc:** Steve Krause <steve.krause@eldercorp.com>; Dan Nixon <DNixon@mcclurevision.com>; Brian Sandberg <bsandberg@mcclurevision.com>; Alex Schlader <aschlader@mcclurevision.com>; Kip Overton <koverton@adeliowa.org>; Whaley, Emily <Emily.Whaley@iowadot.us>  
**Subject:** RE: Adel Trail

Steve,

Pricing for the Manhole Adjustment, Major is approved.

I will get the item added to a change order.

Thanks,



BRIAN MEYER, P.E \*  
PROJECT MANAGER

Your vision. Engineered here.

335 SE Oralabor Rd | Ankeny, IA 50021

D: (515) 303-8014 | O: (515) 964-1229 ext. 2256 | C: (641) 745-7377 | F: (515) 964-2370

\*IA

---

**From:** Steve Frame <[steve.frame@eldercorp.com](mailto:steve.frame@eldercorp.com)>  
**Sent:** Monday, June 10, 2024 4:23 PM  
**To:** Brian Meyer <[bmeyer@mcclurevision.com](mailto:bmeyer@mcclurevision.com)>  
**Cc:** Steve Krause <[steve.krause@eldercorp.com](mailto:steve.krause@eldercorp.com)>  
**Subject:** RE: Adel Trail

Afternoon Brian – worked up price for a major adjustment with the parts and new casting – we would be **\$4,558.00**

Thanks

## Steve Frame

---

**Vice President**

**Cell** 515.249.7473 // **Fax** 515.265.4565

**Email** [Steve.Frame@eldercorp.com](mailto:Steve.Frame@eldercorp.com)



Check out our new [Video](#). You'll dig it!

*"Built on Solid Ground, With Great People."*

Elder Corporation // 5088 East University Ave

Des Moines, IA 50327 // [www.eldercorp.com](http://www.eldercorp.com)

---

**From:** Brian Meyer <[bmeyer@mcclurevision.com](mailto:bmeyer@mcclurevision.com)>

**Sent:** Monday, June 10, 2024 11:18 AM

**To:** Steve Frame <[steve.frame@eldercorp.com](mailto:steve.frame@eldercorp.com)>

**Cc:** Kip Overton <[koverton@adeliowa.org](mailto:koverton@adeliowa.org)>; Kylie Kinter <[kkinter@mcclurevision.com](mailto:kkinter@mcclurevision.com)>; Dan Nixon <[DNixon@mcclurevision.com](mailto:DNixon@mcclurevision.com)>; Alex Schlader <[aschlader@mcclurevision.com](mailto:aschlader@mcclurevision.com)>; Brian Sandberg <[bsandberg@mcclurevision.com](mailto:bsandberg@mcclurevision.com)>; Andrew Orey <[andrew.orey@eldercorp.com](mailto:andrew.orey@eldercorp.com)>

**Subject:** RE: Adel Trail

Steve,

In my discussion with the city, we feel a transition piece with a flat top is the better option. Please submit pricing for a Manhole Adjustment, Major for our review.

Thanks,



BRIAN MEYER, P.E. \*  
PROJECT MANAGER

Your vision. Engineered here.

335 SE Oralabor Rd | Ankeny, IA 50021

D: (515) 303-8014 | O: (515) 964-1229 ext. 2256 | C: (641) 745-7377 | F: (515) 964-2370

\*IA

---

**From:** Kip Overton <[koverton@adeliowa.org](mailto:koverton@adeliowa.org)>

**Sent:** Monday, June 10, 2024 11:13 AM

**To:** Brian Meyer <[bmeyer@mcclurevision.com](mailto:bmeyer@mcclurevision.com)>

**Subject:** Fwd: Adel Trail

Fyi

Get [Outlook for iOS](#)

---

**From:** Steve Krause <[steve.krause@eldercorp.com](mailto:steve.krause@eldercorp.com)>

**Sent:** Monday, June 10, 2024 10:53:49 AM

**To:** Kip Overton <[koverton@adeliowa.org](mailto:koverton@adeliowa.org)>

**Cc:** Steve Frame <[steve.frame@eldercorp.com](mailto:steve.frame@eldercorp.com)>; Andrew Orey <[andrew.orey@eldercorp.com](mailto:andrew.orey@eldercorp.com)>

**Subject:** Adel Trail

**CAUTION:** This email originated from outside the City of Adel's internal network. Do not click links, open attachments, or process requests unless you recognize the sender, know the content is safe, or verify that the request is authentic.

Kip

I talked to our supplier on that manhole. The transition piece is 1.70 tall. The cone sections are 3 feet. With the two pieces it would put us to high. The only other option would be the transition piece, a 1 foot section and a one foot flat top. If you are ok with a flat top manhole we can proceed or we try and patch the existing cone to make it work. Let me know what you would prefer.

Thank you,

## Steve Krause

---

### Field Superintendent

**Cell** 515.249.5883 // **Office** 515.266.3111

**Email** [Steve.Krause@eldercorp.com](mailto:Steve.Krause@eldercorp.com)



Check out our new [Video](#). You'll dig it!

*"Built on Solid Ground, With Great People."*

Elder Corporation // 5088 East University Ave

Des Moines, IA 50327 // [www.eldercorp.com](http://www.eldercorp.com)





# McClure Engineering Co.

## Detailed Payment

25-0035-604

**Description** TAP-U-0035(604)--8I-25, Letting Date- March 19, 2024  
 In the City of Adel, a Rec Trail along Penoach St., S. 12th St., and south of Lynne Dr  
 MEC#: 2022000190-000

**Payment Number** 2

**Pay Period** 06/04/2024 to 06/20/2024

**Prime Contractor** ELDER CORPORATION  
 5088 EAST UNIVERSITY  
 DES MOINES, IA 50327-7098

**Payment Status** Pending

**Awarded Project Amount** \$1,124,000.00

**Authorized Amount** \$1,124,000.00

Line Number	Item ID	Unit	Unit Price	Authorized Quantity	Current Paid Quantity	Previous Paid Quantity	Total Quantity Paid To Date	Total Quantity Placed To Date	Current Payment Amount	Total Amount Paid To Date
<b>Section: 0001 - TAP-U-0035(604)--8I-25, Trail Items</b>										
0010	2101-0850001	ACRE	\$38,500.000	0.230	0.000	0.000	0.000	0.000	\$0.00	\$0.00
CLEARING AND GRUBBING										
0020	2102-2710070	CY	\$7.750	2,477.000	0.000	0.000	0.000	0.000	\$0.00	\$0.00
EXCAVATION, CLASS 10, ROADWAY AND BORROW										

Line Number	Item ID	Unit	Unit Price	Authorized Quantity	Current Paid Quantity	Previous Paid Quantity	Total Quantity Paid To Date	Total Quantity Placed To Date	Current Payment Amount	Total Amount Paid To Date
0030	2102-2710090	CY	\$32.000	806.000	36.000	0.000	36.000	36.000	\$1,152.00	\$1,152.00
EXCAVATION, CLASS 10, WASTE										
0040	2105-8425015	CY	\$15.000	1,532.000	0.000	0.000	0.000	0.000	\$0.00	\$0.00
TOPSOIL, STRIP, SALVAGE AND SPREAD										
0050	2123-7450020	STA	\$380.000	96.000	0.000	0.000	0.000	0.000	\$0.00	\$0.00
SHOULDER FINISHING, EARTH										
0060	2315-8275025	TON	\$60.000	44.000	0.000	0.000	0.000	0.000	\$0.00	\$0.00
SURFACING, DRIVEWAY, CLASS A CRUSHED STONE										
0070	2401-6750001	LS	\$840.000	1.000	0.000	0.000	0.000	0.000	\$0.00	\$0.00
REMOVALS, AS PER PLAN										
0080	2416-0100024	EACH	\$2,300.000	1.000	0.000	0.000	0.000	0.000	\$0.00	\$0.00
APRONS, CONCRETE, 24 IN. DIA.										
0090	2431-0000100	SF	\$90.000	1,467.000	0.000	0.000	0.000	0.000	\$0.00	\$0.00
SEGMENTAL BLOCK RETAINING WALL										
0100	2435-0251224	EACH	\$2,300.000	1.000	0.000	0.000	0.000	0.000	\$0.00	\$0.00
INTAKE, SW-512, 24 IN.										
0110	2435-0600010	EACH	\$1,600.000	5.000	0.000	0.000	0.000	0.000	\$0.00	\$0.00
MANHOLE ADJUSTMENT, MINOR										
0120	2435-0700010	EACH	\$1,200.000	2.000	0.000	0.000	0.000	0.000	\$0.00	\$0.00
CONNECTION TO EXISTING MANHOLE										

Line Number	Item ID	Unit	Unit Price	Authorized Quantity	Current Paid Quantity	Previous Paid Quantity	Total Quantity Paid To Date	Total Quantity Placed To Date	Current Payment Amount	Total Amount Paid To Date
0130	2503-0110015	LF	\$164.000	6.000	0.000	0.000	0.000	0.000	\$0.00	\$0.00
STORM SEWER GRAVITY MAIN, TRENCHED, 15 IN.										
0140	2503-0110024	LF	\$154.000	8.000	0.000	0.000	0.000	0.000	\$0.00	\$0.00
STORM SEWER GRAVITY MAIN, TRENCHED, 24 IN.										
0150	2504-0200404	LF	\$141.000	20.000	0.000	0.000	0.000	0.000	\$0.00	\$0.00
SANITARY SEWER SERVICE STUB, POLYVINYL CHLORIDE PIPE (PVC), 4 IN.										
0160	2511-0302500	SY	\$49.500	4,965.800	1,343.990	0.000	1,343.990	1,343.990	\$66,527.51	\$66,527.51
RECREATIONAL TRAIL, PORTLAND CEMENT CONCRETE, 5 IN.										
0170	2511-0302600	SY	\$55.000	31.800	14.200	0.000	14.200	14.200	\$781.00	\$781.00
RECREATIONAL TRAIL, PORTLAND CEMENT CONCRETE, 6 IN.										
0180	2511-0310100	STA	\$340.000	48.000	0.000	0.000	0.000	0.000	\$0.00	\$0.00
SPECIAL COMPACTION OF SUBGRADE FOR RECREATIONAL TRAIL										
0190	2511-6745900	SY	\$8.750	318.000	203.100	0.000	203.100	203.100	\$1,777.13	\$1,777.13
REMOVAL OF SIDEWALK										
0200	2511-7526004	SY	\$52.000	158.000	26.400	0.000	26.400	26.400	\$1,372.80	\$1,372.80
SIDEWALK, P.C. CONCRETE, 4 IN.										
0210	2511-7526006	SY	\$89.000	104.500	19.200	0.000	19.200	19.200	\$1,708.80	\$1,708.80
SIDEWALK, P.C. CONCRETE, 6 IN.										
0220	2511-7528101	SF	\$51.000	217.000	61.000	0.000	61.000	61.000	\$3,111.00	\$3,111.00
DETECTABLE WARNINGS										

Line Number	Item ID	Unit	Unit Price	Authorized Quantity	Current Paid Quantity	Previous Paid Quantity	Total Quantity Paid To Date	Total Quantity Placed To Date	Current Payment Amount	Total Amount Paid To Date
0230	2514-0000200	STA	\$3,100.000	0.650	0.000	0.000	0.000	0.000	\$0.00	\$0.00
REMOVAL OF CURB										
0240	2515-2475006	SY	\$85.250	173.500	103.900	0.000	103.900	103.900	\$8,857.48	\$8,857.48
DRIVEWAY, P.C. CONCRETE, 6 IN.										
0250	2515-6745600	SY	\$16.500	175.000	0.000	0.000	0.000	0.000	\$0.00	\$0.00
REMOVAL OF PAVED DRIVEWAY										
0260	2516-8625000	CY	\$1,210.000	7.500	7.500	0.000	7.500	7.500	\$9,075.00	\$9,075.00
COMBINED CONCRETE SIDEWALK AND RETAINING WALL										
0270	2519-1002048	LF	\$54.000	77.000	0.000	0.000	0.000	0.000	\$0.00	\$0.00
FENCE, CHAIN LINK, 48 IN. HEIGHT										
0280	2519-4200120	LF	\$5.000	77.000	0.000	0.000	0.000	0.000	\$0.00	\$0.00
REMOVAL OF FENCE, CHAIN LINK										
0290	2524-6765010	EACH	\$550.000	2.000	0.500	0.000	0.500	0.500	\$275.00	\$275.00
REMOVE AND REINSTALL SIGN AS PER PLAN										
0300	2524-9276010	LF	\$35.000	232.000	0.000	0.000	0.000	0.000	\$0.00	\$0.00
PERFORATED SQUARE STEEL TUBE POSTS										
0310	2524-9325001	SF	\$35.000	115.500	0.000	0.000	0.000	0.000	\$0.00	\$0.00
TYPE A SIGNS, SHEET ALUMINUM										
0320	2527-9263109	STA	\$450.000	34.200	0.000	0.000	0.000	0.000	\$0.00	\$0.00
PAINTED PAVEMENT MARKING, WATERBORNE OR SOLVENT-BASED										

Line Number	Item ID	Unit	Unit Price	Authorized Quantity	Current Paid Quantity	Previous Paid Quantity	Total Quantity Paid To Date	Total Quantity Placed To Date	Current Payment Amount	Total Amount Paid To Date
0330	2528-8445110	LS	\$11,200.000	1.000	0.250	0.000	0.250	0.250	\$2,800.00	\$2,800.00
TRAFFIC CONTROL										
0335	2529-2242304	EACH	\$105.000	9.000	8.000	0.000	8.000	8.000	\$840.00	\$840.00
CD JOINT ASSEMBLY										
0340	2529-5070110	SY	\$111.000	103.000	0.000	0.000	0.000	0.000	\$0.00	\$0.00
PATCHES, FULL-DEPTH FINISH, BY AREA										
0350	2529-5070120	EACH	\$476.000	3.000	2.000	0.000	2.000	2.000	\$952.00	\$952.00
PATCHES, FULL-DEPTH FINISH, BY COUNT										
0360	2533-4980005	LS	\$106,277.830	1.000	0.250	0.100	0.350	0.350	\$26,569.46	\$37,197.24
MOBILIZATION										
0370	2554-0210201	EACH	\$6,400.000	1.000	0.000	0.000	0.000	0.000	\$0.00	\$0.00
FIRE HYDRANT ASSEMBLY, WM-201										
0380	2554-0210205	EACH	\$640.000	1.000	0.000	0.000	0.000	0.000	\$0.00	\$0.00
FIRE HYDRANT ASSEMBLY REMOVAL										
0390	2601-2634105	ACRE	\$4,500.000	1.000	0.000	0.000	0.000	0.000	\$0.00	\$0.00
MULCHING, BONDED FIBER MATRIX										
0400	2601-2636015	ACRE	\$2,000.000	0.030	0.000	0.000	0.000	0.000	\$0.00	\$0.00
NATIVE GRASS SEEDING										
0410	2601-2636070	ACRE	\$1,450.000	1.000	0.000	0.000	0.000	0.000	\$0.00	\$0.00
HYDRAULIC SEEDING: (URBAN)										

Line Number	Item ID	Unit	Unit Price	Authorized Quantity	Current Paid Quantity	Previous Paid Quantity	Total Quantity Paid To Date	Total Quantity Placed To Date	Current Payment Amount	Total Amount Paid To Date
0420	2601-2638352	SQ	\$15.000	12.800	0.000	0.000	0.000	0.000	\$0.00	\$0.00
SLOPE PROTECTION, WOOD EXCELSIOR MAT										
0430	2601-2639010	SQ	\$65.000	303.000	0.000	0.000	0.000	0.000	\$0.00	\$0.00
SODDING										
0440	2601-2642120	ACRE	\$850.000	1.000	0.000	0.000	0.000	0.000	\$0.00	\$0.00
STABILIZING CROP - SEEDING AND FERTILIZING (URBAN)										
0450	2601-2643110	MGAL	\$75.000	181.800	0.000	0.000	0.000	0.000	\$0.00	\$0.00
WATERING FOR SOD, SPECIAL DITCH CONTROL, OR SLOPE PROTECTION										
0460	2602-0000020	LF	\$1.600	4,932.000	0.000	0.000	0.000	0.000	\$0.00	\$0.00
SILT FENCE										
0470	2602-0000071	LF	\$0.010	4,932.000	0.000	0.000	0.000	0.000	\$0.00	\$0.00
REMOVAL OF SILT FENCE OR SILT FENCE FOR DITCH CHECKS										
0480	2602-0000101	LF	\$0.010	4,932.000	0.000	0.000	0.000	0.000	\$0.00	\$0.00
MAINTENANCE OF SILT FENCE OR SILT FENCE FOR DITCH CHECK										
0490	2602-0000150	LF	\$25.210	100.000	0.000	0.000	0.000	0.000	\$0.00	\$0.00
STABILIZED CONSTRUCTION ENTRANCE, EC-303										
0500	2602-0000309	LF	\$1.950	2,632.000	325.000	0.000	325.000	325.000	\$633.75	\$633.75
PERIMETER AND SLOPE SEDIMENT CONTROL DEVICE, 9 IN. DIA.										
0510	2602-0000351	LF	\$0.100	2,632.000	0.000	0.000	0.000	0.000	\$0.00	\$0.00
REMOVAL OF PERIMETER AND SLOPE OR DITCH CHECK SEDIMENT CONTROL DEVICE										

Line Number	Item ID	Unit	Unit Price	Authorized Quantity	Current Paid Quantity	Previous Paid Quantity	Total Quantity Paid To Date	Total Quantity Placed To Date	Current Payment Amount	Total Amount Paid To Date
0520	2602-0010010	EACH	\$600.000	1.000	1.000	0.000	1.000	1.000	\$600.00	\$600.00
MOBILIZATIONS, EROSION CONTROL										
0530	2602-0010020	EACH	\$1,200.000	1.000	0.000	0.000	0.000	0.000	\$0.00	\$0.00
MOBILIZATIONS, EMERGENCY EROSION CONTROL										
8001	2435-0600020	EACH	\$0.000	0.000	0.000	0.000	0.000	0.000	\$0.00	\$0.00
MANHOLE ADJUSTMENT, MAJOR										
<b>Section Totals:</b>									\$127,032.93	\$137,660.71
<b>Section: 0002 - TAP-U-0035(604)--8I-25, 80'-0 x 14'-0 Steel Truss Pedestrian Bridge</b>										
0540	2402-2720000	CY	\$33.000	65.000	0.000	0.000	0.000	0.000	\$0.00	\$0.00
EXCAVATION, CLASS 20										
0550	2403-0100010	CY	\$1,150.000	42.100	0.000	0.000	0.000	0.000	\$0.00	\$0.00
STRUCTURAL CONCRETE (BRIDGE)										
0560	2404-7775005	LB	\$2.000	5,744.000	0.000	0.000	0.000	0.000	\$0.00	\$0.00
REINFORCING STEEL, EPOXY COATED										
0570	2414-6445100	LF	\$650.000	42.000	0.000	0.000	0.000	0.000	\$0.00	\$0.00
STRUCTURAL STEEL PEDESTRIAN HAND RAILING										
0580	2429-0000100	EACH	\$160,000.000	1.000	0.000	0.000	0.000	0.000	\$0.00	\$0.00
PRE-ENGINEERED STEEL TRUSS TRAIL BRIDGE,: 80'-0 x 14'-0										
0590	2501-0201057	LF	\$55.000	725.000	0.000	0.000	0.000	0.000	\$0.00	\$0.00
PILES, STEEL, HP 10 X 57										

Line Number	Item ID	Unit	Unit Price	Authorized Quantity	Current Paid Quantity	Previous Paid Quantity	Total Quantity Paid To Date	Total Quantity Placed To Date	Current Payment Amount	Total Amount Paid To Date
0600	2507-2638650	SY	\$150.000	19.000	0.000	0.000	0.000	0.000	\$0.00	\$0.00
BRIDGE WING ARMORING - EROSION STONE										
0610	2507-3250005	SY	\$6.000	162.000	0.000	0.000	0.000	0.000	\$0.00	\$0.00
ENGINEERING FABRIC										
0620	2507-6800061	TON	\$69.000	123.000	0.000	0.000	0.000	0.000	\$0.00	\$0.00
REVTMENT, CLASS E										
<b>Section Totals:</b>									\$0.00	\$0.00
<b>Total Payments:</b>									\$127,032.93	\$137,660.71

### Time Charges

Time Limit	Original Deadline	Authorized Deadline	Charges This Period	Damages This Period	Days Completed To Date	Days Remaining To Date	Damages To Date
Working Days, Late Start Date - 06/03/2024, Liquidated Damage Rate - 1,000	75.0 Days	75.0 Days	11.0 Days	\$0.00	11.0 Days	64.0 Days	\$0.00
<b>Total Damages:</b>							\$0.00

## Summary

<b>Current Approved Work:</b>	\$127,032.93
<b>Current Stockpile Advancement:</b>	\$0.00
<b>Current Stockpile Recovery:</b>	\$0.00
<b>Current Retainage:</b>	\$3,810.99
<b>Current Retainage Released:</b>	\$0.00
<b>Current Liquidated Damages:</b>	\$0.00
<b>Current Adjustment:</b>	\$0.00
<b>Current Payment:</b>	\$123,221.94
<b>Previous Payment:</b>	\$10,308.95

<b>Approved Work To Date:</b>	\$137,660.71
<b>Stockpile Advancement To Date:</b>	\$0.00
<b>Stockpile Recovery To Date:</b>	\$0.00
<b>Retainage To Date:</b>	\$4,129.82
<b>Retainage Released To Date:</b>	\$0.00
<b>Liquidated Damages To Date:</b>	\$0.00
<b>Adjustments To Date:</b>	\$0.00
<b>Payments To Date:</b>	\$133,530.89
<b>Previous Payments To Date:</b>	\$10,308.95

## Funding Details

<b>25-0035-604-CAT-1 25-0035-604-CAT-1 25-0035-604:</b>	\$127,032.93
<b>25-0035-604-CAT-2 25-0035-604-CAT-2 25-0035-604:</b>	\$0.00
<b>25-0035-604-CAT-3 NON-PARTICIPATING:</b>	\$0.00
<b>Current Payment:</b>	\$127,032.93

<b>25-0035-604-CAT-1 25-0035-604-CAT-1 25-0035-604 To Date:</b>	\$137,660.71
<b>25-0035-604-CAT-2 25-0035-604-CAT-2 25-0035-604 To Date:</b>	\$0.00
<b>25-0035-604-CAT-3 NON-PARTICIPATING To Date:</b>	\$0.00
<b>Payments To Date:</b>	\$137,660.71



# McClure Engineering Co.

## Change Order Details

25-0035-603

---

<b>Description</b>	BRM-0035(603)--8N-25, Acct ID- 39641, Letting Date- September 19, 2023 MEC Project #: 0000211533-000
<b>Prime Contractor</b>	HERBERGER CONSTRUCTION CO., INC. 2508 WEST 2ND AVENUE INDIANOLA, IA 50125-0000
<b>Change Order</b>	2
<b>Status</b>	Pending
<b>Date Created</b>	06/26/2024
<b>Type</b>	Design Change
<b>Summary</b>	Pile Encasement
<b>Change Order Description</b>	The total quantity of pile encasement will increase from 260LF to 304.1LF. Decrease Item 0180, 2501-5478042, CONCRETE ENCASEMENT OF STEEL H PILES, HP 10 X 42 (P10L TYPE 3) by 260 LF Add Item 8002, 2501-5478042, CONCRETE ENCASEMENT OF STEEL H PILES, HP 10 X 42(P10L TYPE 3), 304.1LF 4 Additional Working Days will be added for this work.
<b>Awarded Project Amount</b>	\$1,099,367.96
<b>Authorized Project Amount</b>	\$1,103,712.96
<b>Change Order Amount</b>	\$11,436.50
<b>Revised Project Amount</b>	\$1,115,149.46

**B – Reason for change:**

After reviewing the site conditions, creek bed elevations, and planned elevations for Item 0180, 2501-5478042, CONCRETE ENCASUREMENT OF STEEL H PILES, HP 10 X 42 (P10L TYPE 3), it was determined that the pile encasement would need to go deeper than plan depth. The deeper excavation would require increased effort from Herberger as a part of the incidental Class 21 that is included as a part of the pile encasement. The additional effort includes sheet piling or trench boxes, dewatering, and increased excavation of fill. The class 21 fill will increase from 25CY to 82CY total. Thus a new item will be needed to include the incidental C1 21. The new item will be Item 8002, 2501-5478042, CONCRETE ENCASUREMENT OF STEEL H PILES, HP 10 X 42(P10L TYPE 3)

**C – Settlement for cost(s) of change as with items addressed in sections F and/or G:**

Item 0180, 2501-5478042, CONCRETE ENCASUREMENT OF STEEL H PILES, HP 10 X 42 (P10L TYPE 3): Contract Price: 260LFx\$149/LF=\$38,740.

Item 8002, 2501-5478042, CONCRETE ENCASUREMENT OF STEEL H PILES, HP 10 X 42(P10L TYPE 3): 304.1LFx\$165/LF=\$50,176.50

Change in Price: \$50,176.50-\$38,740=\$11,436.50

**D – Justification for cost(s):**

Contract price for Item 0180, 2501-5478042, CONCRETE ENCASUREMENT OF STEEL H PILES, HP 10 X 42 (P10L TYPE 3)

Price for Item 8002, 2501-5478042, CONCRETE ENCASUREMENT OF STEEL H PILES, HP 10 X 42(P10L TYPE 3) compares favorably with historic pricing based on bid prices collected in the past year. Price includes all mobilization, labor, equipment, and materials to accomplish the work.

**Increases/Decreases**

Line Number	Item ID	Unit	Unit Price	Current		Change		Revised	
				Quantity	Amount	Quantity	Amount	Quantity	Amount
<b>Section: 0001 - BRM-0035(603)--8N-25, Acct ID- 39641, ITEMS FOR 100'-0 X 36'-0 CONTINUOUS CONCRETE SLAB BRIDGE</b>									
0180	2501-5478042	LF	\$149.000	260.000	\$38,740.00	-260.000	-\$38,740.00	0.000	\$0.00
CONCRETE ENCASUREMENT OF STEEL H PILES, HP 10 X 42 (P10L TYPE 3)									

Line Number	Item ID	Unit	Unit Price	Current		Change		Revised	
				Quantity	Amount	Quantity	Amount	Quantity	Amount

**Reason:** Contract Unit Price

Funding Details									
	25-0035-603-CAT-1	25-0035-603-CAT-1	25-0035-603	260.000	\$38,740.00	-260.000	-\$38,740.00	0.000	\$0.00
	25-0035-603-CAT-3	25-0035-603-CAT-3	25-0035-603	0.000	\$0.00	0.000	\$0.00	0.000	\$0.00
1 item	Totals				\$38,740.00		-\$38,740.00		\$0.00

### New Items

Line Number	Item ID	Unit	Quantity	Unit Price	Extension
-------------	---------	------	----------	------------	-----------

**Section: 0001 - BRM-0035(603)--8N-25, Acct ID- 39641, ITEMS FOR 100'-0 X 36'-0 CONTINUOUS CONCRETE SLAB BRIDGE**

8002	2501-5478042	LF	304.100	\$165.000	\$50,176.50
CONCRETE ENCASEMENT OF STEEL H PILES, HP 10 X 42(P10L TYPE 3)					

**Reason:** Price Compares Favorably with historic pricing. Price includes all materials, equipment, and mobilization to accomplish this work.

Funding Details						
	25-0035-603-CAT-1	25-0035-603-CAT-1	25-0035-603	304.100	\$165.000	\$50,176.50
1 item	Total: \$50,176.50					

## Funding Summary

Fund Package	Original Amount	Authorized Amount	Pending Change	Revised Amount
25-0035-603-CAT-1 25-0035-603-CAT-1 25-0035-603	\$1,021,157.96	\$1,025,502.96	\$11,436.50	\$1,036,939.46
25-0035-603-CAT-3 25-0035-603-CAT-3 25-0035-603	\$78,210.00	\$78,210.00	\$0.00	\$78,210.00
2 fund packages	\$1,099,367.96	\$1,103,712.96	\$11,436.50	\$1,115,149.46

## Time Limit Changes

Type	Original Deadline	Current Deadline	Pending Extension	Pending Deadline
Working Days	85.0 Days	85.0 Days	4.0 Days	89.0 Days
Working Days, Late Start Date - 07/08/2024, Liquidated Damage Rate - 1,000				
<b>Reason:</b> Change Order 2				
1 time limit				

This Document will become a supplement to the Contract and all provisions will apply hereto.

\_\_\_\_\_  
McClure Engineering Company

\_\_\_\_\_  
Date

\_\_\_\_\_  
Herberger Construction

\_\_\_\_\_  
Date

\_\_\_\_\_  
City of Adel

\_\_\_\_\_  
Date

## Brian Meyer

---

**From:** Elias Else <elias@herbergerconstruction.com>  
**Sent:** Tuesday, May 28, 2024 4:38 PM  
**To:** Brian Meyer  
**Cc:** Brian Sandberg; Dan Nixon; Camron Collier  
**Subject:** RE: 15th Street Bridge Encasement Elevations

Brian,

We have reviewed the design change of the pier encasements and we need to ask for an EWO for the additional Class 21 excavation associated with deeper pier encasements. According to the DOT spec, if there isn't a bid item for Class 21, then Class 21 excavation is incidental to the per foot bid price of concrete encasements. The original quantity of Class 21 was about 25 CY, as per my takeoff I sent on May 13. This change in encasement depth added about 57 CY of Class 21 for a total of 82 CY of Class 21, 41 CY per pier.

We ask for an increase of \$16.00/foot above our bid price for a total of \$165.00/foot for the entire 304.1 feet of encasements. We also ask for 4 working days be added to the contract for the additional excavation and additional encasement footage to install. Please advise.

Sincerely,

Elias Else, P.E.  
(515)249-1369



---

**From:** Brian Meyer <[bmeyer@mclurevision.com](mailto:bmeyer@mclurevision.com)>  
**Sent:** Tuesday, May 14, 2024 3:57 PM  
**To:** Elias Else <[elias@herbergerconstruction.com](mailto:elias@herbergerconstruction.com)>  
**Cc:** Brian Sandberg <[bsandberg@mclurevision.com](mailto:bsandberg@mclurevision.com)>; Dan Nixon <[DNixon@mclurevision.com](mailto:DNixon@mclurevision.com)>; Camron Collier <[camron@herbergerconstruction.com](mailto:camron@herbergerconstruction.com)>  
**Subject:** RE: 15th Street Bridge Encasement Elevations

Eli,

We appreciate the information we are working on verifying the quantity you sent over.

Do you have an approximate cost for the additional excavation?

Thanks,



BRIAN MEYER, P.E. \*  
PROJECT MANAGER

Your vision. Engineered here.

335 SE Oralabor Rd | Ankeny, IA 50021

D: (515) 303-8014 | O: (515) 964-1229 ext. 2256 | C: (641) 745-7377 | F: (515) 964-2370

\*IA

---

**From:** Elias Else <[elias@herbergerconstruction.com](mailto:elias@herbergerconstruction.com)>  
**Sent:** Monday, May 13, 2024 1:07 PM  
**To:** Brian Meyer <[bmeyer@mcclurevision.com](mailto:bmeyer@mcclurevision.com)>  
**Cc:** Brian Sandberg <[bsandberg@mcclurevision.com](mailto:bsandberg@mcclurevision.com)>; Dan Nixon <[DNixon@mcclurevision.com](mailto:DNixon@mcclurevision.com)>; Camron Collier <[camron@herbergerconstruction.com](mailto:camron@herbergerconstruction.com)>  
**Subject:** RE: 15th Street Bridge Encasement Elevations

Brian,

Thanks for getting this back to me. I have double checked the design lengths, drew it up in autocad, and came up with these adjustment values. Do you concur? If so, I will need to work up a new unit price to account for the extra class 21 that is incidental to the encasements. I have attached my drawing as a .pdf as well as a .dwg if you would double check my values please. Let me know if you find any errors on my end.

Thanks,

Elias Else, P.E.  
(515)249-1369



---

**From:** Brian Meyer <[bmeyer@mcclurevision.com](mailto:bmeyer@mcclurevision.com)>  
**Sent:** Monday, May 6, 2024 9:33 AM  
**To:** [elias@herbergerconstruction.com](mailto:elias@herbergerconstruction.com)  
**Cc:** Brian Sandberg <[bsandberg@mcclurevision.com](mailto:bsandberg@mcclurevision.com)>; Dan Nixon <[DNixon@mcclurevision.com](mailto:DNixon@mcclurevision.com)>  
**Subject:** FW: 15th Street Bridge Encasement Elevations

Eli,

Below is the adjusted elevation for the piling encasements. Let me know if you have any questions or need anything else.

Thanks,



BRIAN MEYER, P.E \*  
PROJECT MANAGER

Your vision. Engineered here.  
335 SE Oralabor Rd | Ankeny, IA 50021  
D: (515) 303-8014 | O: (515) 964-1229 ext. 2256 | C: (641) 745-7377 | F: (515) 964-2370

\*IA

---

**From:** Brian Sandberg <[bsandberg@mcclurevision.com](mailto:bsandberg@mcclurevision.com)>  
**Sent:** Monday, May 6, 2024 9:18 AM  
**To:** Brian Meyer <[bmeyer@mcclurevision.com](mailto:bmeyer@mcclurevision.com)>  
**Cc:** Chad Meyer <[chad.meyer@mcclurevision.com](mailto:chad.meyer@mcclurevision.com)>  
**Subject:** 15th Street Bridge Encasement Elevations

Brian,

Herberger should plan for all the encasements to extend 3' below the creek flowline, which in our case would be **878.67.**

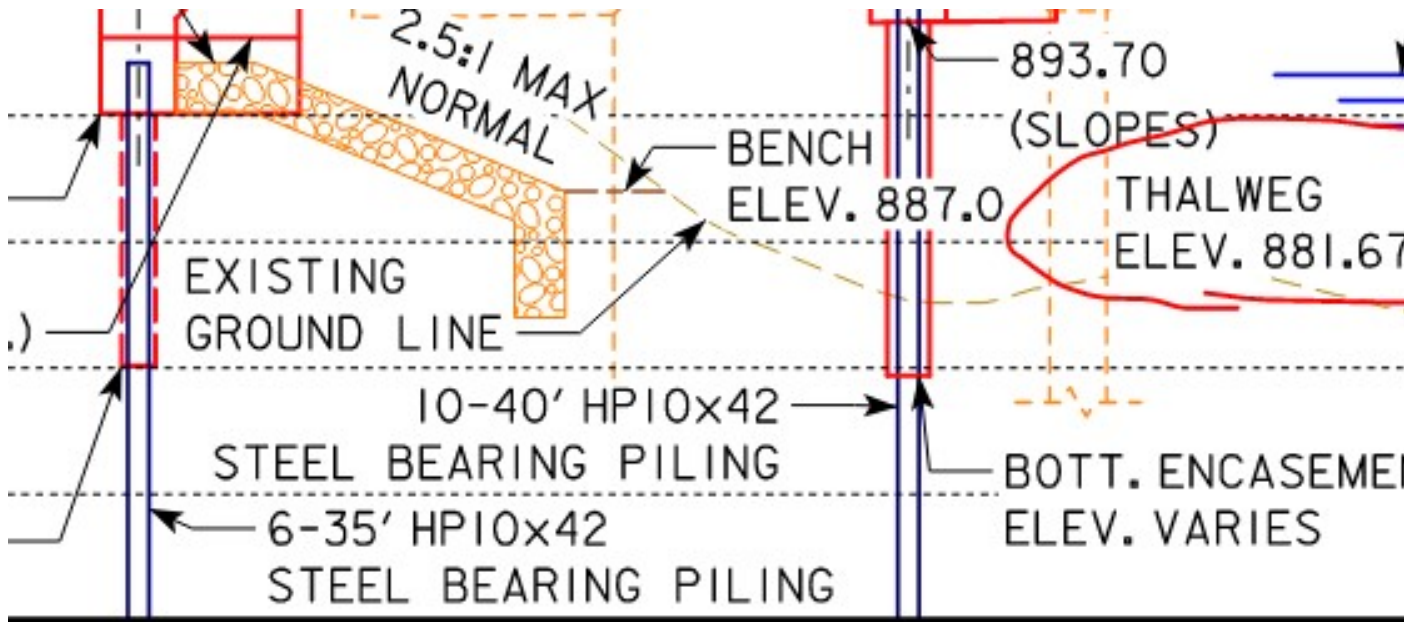

# LONGITUDINAL SECTION A



**MCCLURE**

[mcclurevision.com](http://mcclurevision.com)

BRIAN SANDBERG, P.E.\*  
SENIOR PROJECT ENGINEER

Your vision. Engineered here.

1360 NW 121st Street | Clive, IA 50325

D: (515) 303-8169 | O: (515) 964-1229 ext. 2055 | C: (515) 230-5731 | F: (515) 964-2370

\*IA

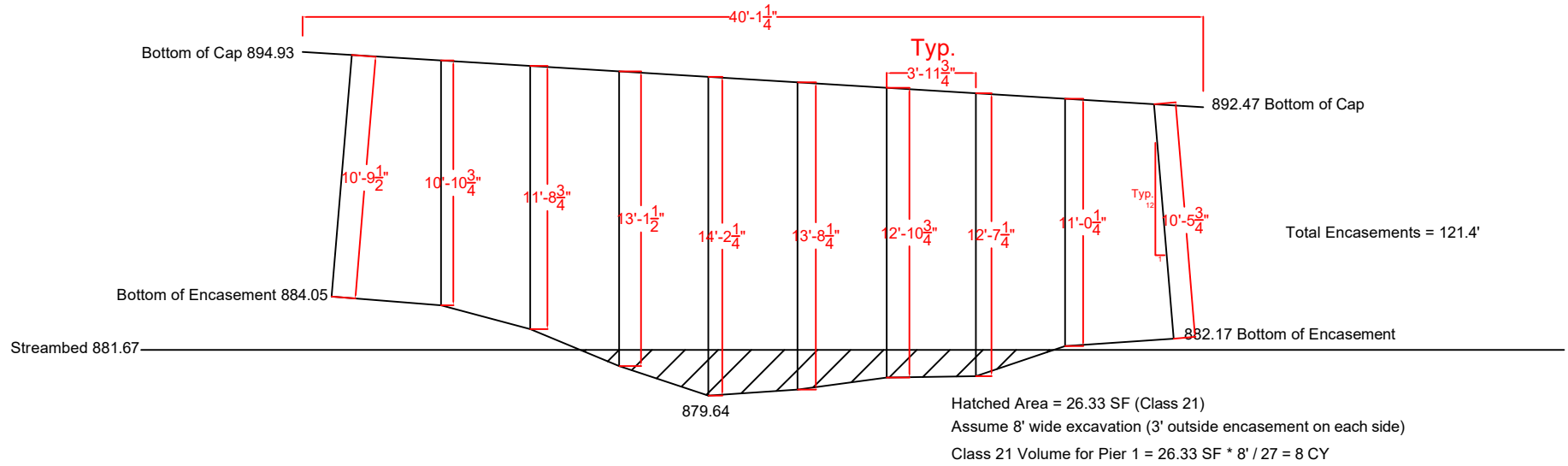

Changed Pier 1

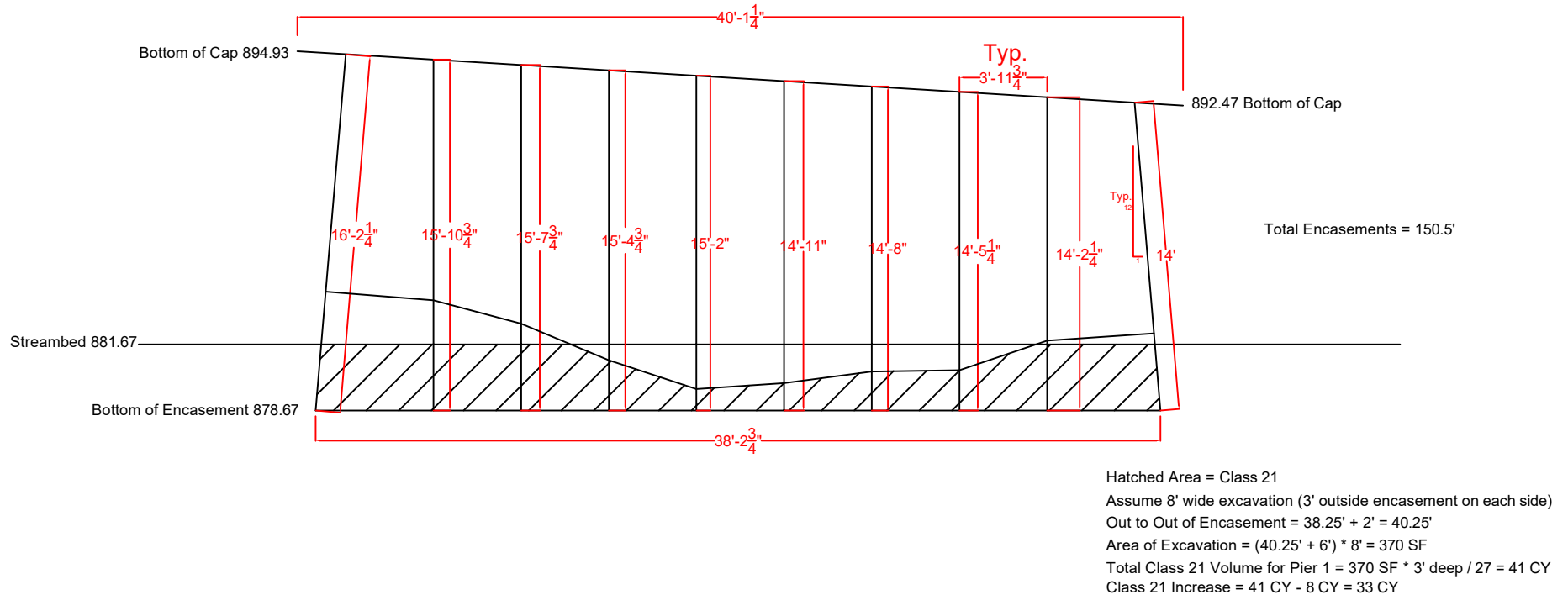

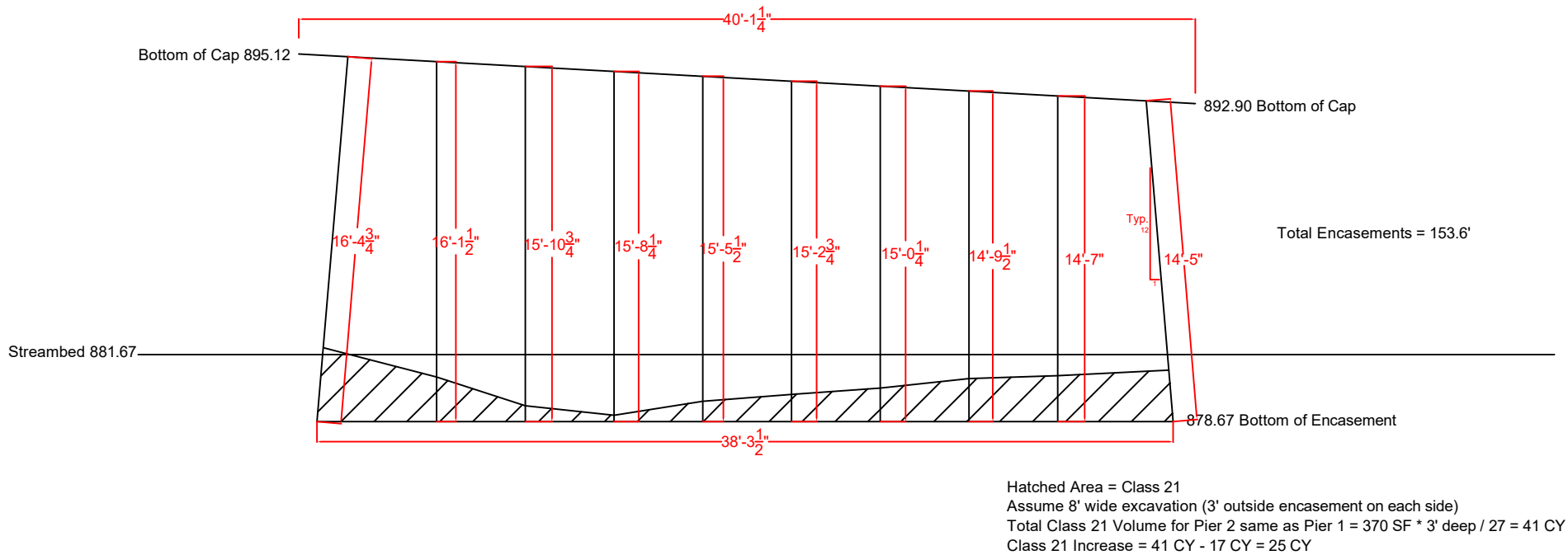
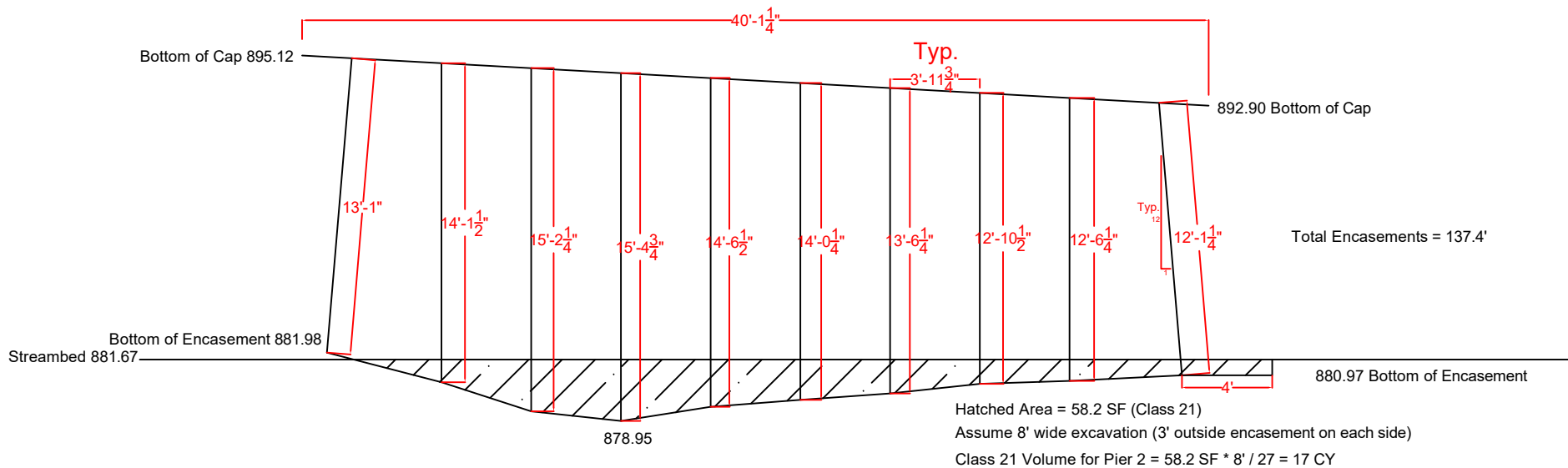



# McClure Engineering Co.

## Detailed Payment

25-0035-603

**Description** BRM-0035(603)--8N-25, Acct ID- 39641, Letting Date- September 19, 2023  
MEC Project #: 0000211533-000

**Payment Number** 3

**Pay Period** 04/05/2024 to 06/20/2024

**Prime Contractor** HERBERGER CONSTRUCTION CO., INC.  
2508 WEST 2ND AVENUE  
INDIANOLA, IA 50125-0000

**Payment Status** Pending

**Awarded Project Amount** \$1,099,367.96

**Authorized Amount** \$1,103,712.96

Line Number	Item ID	Unit	Unit Price	Authorized Quantity	Current Paid Quantity	Previous Paid Quantity	Total Quantity Paid To Date	Total Quantity Placed To Date	Current Payment Amount	Total Amount Paid To Date
<b>Section: 0001 - BRM-0035(603)--8N-25, Acct ID- 39641, ITEMS FOR 100'-0 X 36'-0 CONTINUOUS CONCRETE SLAB BRIDGE</b>										
0010	2101-0850001	ACRE	\$90,000.000	0.110	0.000	0.120	0.120	0.120	\$0.00	\$10,800.00
CLEARING AND GRUBBING										
0020	2102-2710070	CY	\$9.000	994.000	0.000	0.000	0.000	0.000	\$0.00	\$0.00
EXCAVATION, CLASS 10, ROADWAY AND BORROW										

Line Number	Item ID	Unit	Unit Price	Authorized Quantity	Current Paid Quantity	Previous Paid Quantity	Total Quantity Paid To Date	Total Quantity Placed To Date	Current Payment Amount	Total Amount Paid To Date
0030	2102-2710090	CY	\$24.000	260.000	0.000	0.000	0.000	0.000	\$0.00	\$0.00
EXCAVATION, CLASS 10, WASTE										
0040	2105-8425015	CY	\$14.000	206.000	0.000	0.000	0.000	0.000	\$0.00	\$0.00
TOPSOIL, STRIP, SALVAGE AND SPREAD										
0050	2123-7450020	STA	\$400.000	2.900	0.000	0.000	0.000	0.000	\$0.00	\$0.00
SHOULDER FINISHING, EARTH										
0060	2212-5070310	SY	\$320.000	50.000	0.000	0.000	0.000	0.000	\$0.00	\$0.00
PATCHES, FULL-DEPTH REPAIR										
0070	2212-5070330	EACH	\$325.000	2.000	0.000	0.000	0.000	0.000	\$0.00	\$0.00
PATCHES BY COUNT (REPAIR)										
0080	2301-0690205	SY	\$290.000	686.800	0.000	0.000	0.000	0.000	\$0.00	\$0.00
BRIDGE APPROACH, BR-205										
0090	2301-6911722	LS	\$1.000	1.000	0.000	0.000	0.000	0.000	\$0.00	\$0.00
PORTLAND CEMENT CONCRETE PAVEMENT SAMPLES										
0100	2303-6911000	LS	\$650.000	1.000	0.000	0.000	0.000	0.000	\$0.00	\$0.00
HOT MIX ASPHALT PAVEMENT SAMPLES										
0110	2401-6745625	LS	\$48,000.000	1.000	0.000	0.000	0.000	0.000	\$0.00	\$0.00
REMOVAL OF EXISTING BRIDGE										
0120	2402-2720000	CY	\$40.000	96.000	0.000	0.000	0.000	0.000	\$0.00	\$0.00
EXCAVATION, CLASS 20										

Line Number	Item ID	Unit	Unit Price	Authorized Quantity	Current Paid Quantity	Previous Paid Quantity	Total Quantity Paid To Date	Total Quantity Placed To Date	Current Payment Amount	Total Amount Paid To Date
0130	2403-0100010	CY	\$926.000	267.000	0.000	0.000	0.000	0.000	\$0.00	\$0.00
STRUCTURAL CONCRETE (BRIDGE)										
0140	2404-7775000	LB	\$4.800	124.000	0.000	0.000	0.000	0.000	\$0.00	\$0.00
REINFORCING STEEL										
0150	2404-7775005	LB	\$1.800	69,067.000	0.000	0.000	0.000	0.000	\$0.00	\$0.00
REINFORCING STEEL, EPOXY COATED										
0160	2414-6424110	LF	\$90.000	222.200	0.000	0.000	0.000	0.000	\$0.00	\$0.00
CONCRETE BARRIER RAILING										
0170	2501-0201042	LF	\$57.000	1,170.000	0.000	0.000	0.000	0.000	\$0.00	\$0.00
PILES, STEEL, HP 10 X 42										
0180	2501-5478042	LF	\$149.000	260.000	0.000	0.000	0.000	0.000	\$0.00	\$0.00
CONCRETE ENCASEMENT OF STEEL H PILES, HP 10 X 42 (P10L TYPE 3)										
0190	2501-6335010	LF	\$58.000	120.000	0.000	0.000	0.000	0.000	\$0.00	\$0.00
PREBORED HOLES										
0200	2505-4008120	LF	\$9.500	106.000	0.000	0.000	0.000	0.000	\$0.00	\$0.00
REMOVAL OF STEEL BEAM GUARDRAIL										
0210	2505-4008300	LF	\$35.000	37.500	0.000	0.000	0.000	0.000	\$0.00	\$0.00
STEEL BEAM GUARDRAIL										
0220	2505-4008420	EACH	\$1,800.000	3.000	0.000	0.000	0.000	0.000	\$0.00	\$0.00
STEEL BEAM GUARDRAIL BARRIER TRANSITION SECTION, BA-221										

Line Number	Item ID	Unit	Unit Price	Authorized Quantity	Current Paid Quantity	Previous Paid Quantity	Total Quantity Paid To Date	Total Quantity Placed To Date	Current Payment Amount	Total Amount Paid To Date
0230	2505-4021010	EACH	\$400.000	3.000	0.000	0.000	0.000	0.000	\$0.00	\$0.00
STEEL BEAM GUARDRAIL END ANCHOR, BOLTED										
0240	2505-4021722	EACH	\$2,800.000	3.000	0.000	0.000	0.000	0.000	\$0.00	\$0.00
STEEL BEAM GUARDRAIL TANGENT END TERMINAL, BA-225										
0250	2507-3250005	SY	\$4.200	275.000	0.000	0.000	0.000	0.000	\$0.00	\$0.00
ENGINEERING FABRIC										
0260	2507-6800061	TON	\$75.000	380.000	0.000	0.000	0.000	0.000	\$0.00	\$0.00
REVTMENT, CLASS E										
0270	2510-6745850	SY	\$30.000	429.600	0.000	0.000	0.000	0.000	\$0.00	\$0.00
REMOVAL OF PAVEMENT										
0280	2524-6765010	EACH	\$420.000	2.000	0.000	0.000	0.000	0.000	\$0.00	\$0.00
REMOVE AND REINSTALL SIGN AS PER PLAN										
0290	2527-9263109	STA	\$210.000	17.800	0.000	0.000	0.000	0.000	\$0.00	\$0.00
PAINTED PAVEMENT MARKING, WATERBORNE OR SOLVENT-BASED										
0300	2528-2518000	EACH	\$250.000	2.000	2.000	0.000	2.000	2.000	\$500.00	\$500.00
SAFETY CLOSURE										
0310	2528-8445110	LS	\$13,500.000	1.000	0.000	0.250	0.250	0.250	\$0.00	\$3,375.00
TRAFFIC CONTROL										
0320	2528-9290050	CDAY	\$210.000	10.000	10.000	15.000	25.000	25.000	\$2,100.00	\$5,250.00
PORTABLE DYNAMIC MESSAGE SIGN (PDMS)										

Line Number	Item ID	Unit	Unit Price	Authorized Quantity	Current Paid Quantity	Previous Paid Quantity	Total Quantity Paid To Date	Total Quantity Placed To Date	Current Payment Amount	Total Amount Paid To Date
0330	2533-4980005	LS	\$61,000.000	1.000	0.400	0.100	0.500	0.500	\$24,400.00	\$30,500.00
MOBILIZATION										
0340	2551-0000230	EACH	\$31,000.000	1.000	0.000	0.000	0.000	0.000	\$0.00	\$0.00
PERMANENT CRASH CUSHION, SEVERE USE (SU)										
0350	2551-0000300	EACH	\$500.000	1.000	0.000	0.000	0.000	0.000	\$0.00	\$0.00
PERMANENT CRASH CUSHION SPARE PARTS KIT										
0360	2554-0202200	EACH	\$3,050.000	4.000	4.000	0.000	4.000	4.000	\$12,200.00	\$12,200.00
FITTINGS BY COUNT, DUCTILE IRON,: 12 IN. 22.5 DEGREE BEND										
0370	2554-0202200	EACH	\$5,950.000	2.000	2.000	0.000	2.000	2.000	\$11,900.00	\$11,900.00
FITTINGS BY COUNT, DUCTILE IRON,: 12 IN. X 10 IN. REDUCER										
0380	2554-0207012	EACH	\$6,475.000	2.000	2.000	0.000	2.000	2.000	\$12,950.00	\$12,950.00
VALVE, GATE, DIP, 12 IN.										
0390	2601-2634100	ACRE	\$2,500.000	0.500	0.000	0.220	0.220	0.220	\$0.00	\$550.00
MULCHING										
0400	2601-2636018	ACRE	\$15,000.000	0.010	0.000	0.000	0.000	0.000	\$0.00	\$0.00
WETLAND GRASS SEEDING										
0410	2601-2636043	ACRE	\$3,500.000	0.500	0.000	0.000	0.000	0.000	\$0.00	\$0.00
SEEDING AND FERTILIZING (RURAL)										
0420	2601-2638352	SQ	\$25.000	45.000	0.000	0.000	0.000	0.000	\$0.00	\$0.00
SLOPE PROTECTION, WOOD EXCELSIOR MAT										

Line Number	Item ID	Unit	Unit Price	Authorized Quantity	Current Paid Quantity	Previous Paid Quantity	Total Quantity Paid To Date	Total Quantity Placed To Date	Current Payment Amount	Total Amount Paid To Date
0430	2601-2642100	ACRE	\$400.000	0.500	0.000	0.220	0.220	0.220	\$0.00	\$88.00
STABILIZING CROP - SEEDING AND FERTILIZING										
0440	2602-0000020	LF	\$5.000	766.000	0.000	0.000	0.000	0.000	\$0.00	\$0.00
SILT FENCE										
0450	2602-0000071	LF	\$0.010	766.000	0.000	0.000	0.000	0.000	\$0.00	\$0.00
REMOVAL OF SILT FENCE OR SILT FENCE FOR DITCH CHECKS										
0460	2602-0000101	LF	\$1.000	766.000	0.000	0.000	0.000	0.000	\$0.00	\$0.00
MAINTENANCE OF SILT FENCE OR SILT FENCE FOR DITCH CHECK										
8000	2602-0000309	LF	\$3.300	500.000	0.000	362.000	362.000	362.000	\$0.00	\$1,194.60
PERIMETER AND SLOPE SEDIMENT CONTROL DEVICE, 9 IN. DIA.										
8001	2599-9999010	LS	\$2,695.000	1.000	1.000	0.000	1.000	1.000	\$2,695.00	\$2,695.00
('LUMP SUM' ITEM): Additional Detour Signing										
8002	2501-5478042	LF	\$0.000	0.000	0.000	0.000	0.000	0.000	\$0.00	\$0.00
CONCRETE ENCASEMENT OF STEEL H PILES, HP 10 X 42(P10L TYPE 3)										
<b>Section Totals:</b>									\$66,745.00	\$92,002.60
<b>Section: 0003 - BRM-0035(603)--8N-25, Acct ID- 39641, ALTERNATE ?AA? OPTION 2: WATER MAIN, TRENCHLESS, BID THIS SECTION IF ALTERNATE ?AA? OPTION 2 IS CHOSEN</b>										
0490	2554-0124012	LF	\$237.000	330.000	330.000	0.000	330.000	330.000	\$78,210.00	\$78,210.00
WATER MAIN, TRENCHLESS, POLYVINYL CHLORIDE PIPE (PVC), 12 IN.										
<b>Section Totals:</b>									\$78,210.00	\$78,210.00
<b>Total Payments:</b>									\$144,955.00	\$170,212.60

### Time Charges

Time Limit	Original Deadline	Authorized Deadline	Charges This Period	Damages This Period	Days Completed To Date	Days Remaining To Date	Damages To Date
Working Days, Late Start Date - 07/08/2024, Liquidated Damage Rate - 1,000	85.0 Days	85.0 Days	8.0 Days	\$0.00	8.0 Days	77.0 Days	\$0.00
<b>Total Damages:</b>							\$0.00

### Stockpiles

Stockpile	Fund Package	Current Advancements	Advancements To Date	Current Recoveries	Recoveries To Date
#1 - 2501-0201042 PILES, STEEL, HP 10 X 42	25-0035-603-CAT-1 25-0035-603-CAT-1 25-0035-603	\$0.00	\$29,526.12	\$0.00	\$0.00
<b>Totals:</b>		\$0.00	\$29,526.12	\$0.00	\$0.00

## Summary

<b>Current Approved Work:</b>	\$144,955.00
<b>Current Stockpile Advancement:</b>	\$0.00
<b>Current Stockpile Recovery:</b>	\$0.00
<b>Current Retainage:</b>	\$4,348.65
<b>Current Retainage Released:</b>	\$0.00
<b>Current Liquidated Damages:</b>	\$0.00
<b>Current Adjustment:</b>	\$0.00
<b>Current Payment:</b>	\$140,606.35
<b>Previous Payment:</b>	\$47,925.99

<b>Approved Work To Date:</b>	\$170,212.60
<b>Stockpile Advancement To Date:</b>	\$29,526.12
<b>Stockpile Recovery To Date:</b>	\$0.00
<b>Retainage To Date:</b>	\$5,106.38
<b>Retainage Released To Date:</b>	\$0.00
<b>Liquidated Damages To Date:</b>	\$0.00
<b>Adjustments To Date:</b>	\$0.00
<b>Payments To Date:</b>	\$194,632.34
<b>Previous Payments To Date:</b>	\$54,025.99

## Funding Details

<b>25-0035-603-CAT-1 25-0035-603-CAT-1 25-0035-603:</b>	\$66,745.00
<b>25-0035-603-CAT-3 25-0035-603-CAT-3 25-0035-603:</b>	\$78,210.00
<b>Current Payment:</b>	\$144,955.00

<b>25-0035-603-CAT-1 25-0035-603-CAT-1 25-0035-603 To Date:</b>	\$92,002.60
<b>25-0035-603-CAT-3 25-0035-603-CAT-3 25-0035-603 To Date:</b>	\$78,210.00
<b>Payments To Date:</b>	\$170,212.60



**AGENDA ITEM NO. 6.a**  
**AGENDA SECTION: NEW**  
**BUSINESS**

## **ADEL CITY COUNCIL AGENDA ITEM REPORT**

**MEETING DATE:** July 9, 2024

**TO:** Mayor & City Council

**FROM:** Carrie Erickson, City Clerk

**AGENDA HEADING:** Consider Approval of Mayor Board and Commission Appointments: Historic Preservation Commission - One Opening

**STAFF/COMMITTEE RECOMMENDATION:**

This item considers having the Mayor appoint one resident to fill one vacant term (ending on July 1, 2026) on the City's Historic Preservation Commission.

As of Friday, July 5 at 12:00 p.m., one application has been received: Anna Phelps.

On Wednesday, April 3, Governor Reynolds signed SF 2096 into law, which repealed Iowa Code 69.16A - Gender Balance.

City staff will issue any additional applications received before the council meeting if possible.

**ATTACHMENTS:**

[Honor The Call To Serve - HPC June Vacancy 2024 \(Round 2\).pdf](#)  
[Anna Phelps - HPC Application.pdf](#)



## HONOR THE CALL TO SERVE

Serving on a City Board or Commission is a great way to become involved in shaping the direction of your community. If you've ever wanted to become a part of the decision-making process, please visit the City's website to complete an application:

<https://adeliowa.org/permits-and-forms/serve-on-a-city-board-or-commission/>  
or contact the City Clerk at 515-993-4525 to request a copy of the application.

### Historic Preservation Commission – One Opening\*

The Historic Preservation Commission promotes the educational, cultural, economic, and general welfare of the public through the recognition, enhancement, and perpetuation of districts and sites of historical and cultural significance. Please see Chapter 25 of the City of Adel Code of Ordinances for further details. Terms are for three (3) years. The commission meets on the third Tuesday of every month at 8:00 p.m. at Adel City Hall.

\*Term ends July 1, 2026 and is to fill a vacancy in the Commission. Mayoral appointment with council approval. Please contact City Administrator Anthony Brown with any specific questions about the commission.

*We anticipate appointing this position at the July 9, 2024 Adel City Council Meeting. While your attendance is not required, we encourage you to participate in case the Mayor or Council have any additional questions.*

**APPLICATIONS SUBMITTED BY JULY 3 WILL BE INCLUDED  
IN THE COUNCIL PACKET ISSUED ON JULY 5**

**From:** [website@mg.adeliowa.org](mailto:website@mg.adeliowa.org) on behalf of [Adel Iowa](#)  
**To:** [Carrie Erickson](#); [Anthony Brown](#)  
**Subject:** New submission from Application to Serve on a City Board or Commission  
**Date:** Tuesday, June 11, 2024 9:19:47 PM

**CAUTION:** This email originated from outside the City of Adel's internal network. Do not click links, open attachments, or process requests unless you recognize the sender, know the content is safe, or verify that the request is authentic.

**Name**

Anna Phelps

**Address**

875  
4th Street  
Waukee, IA 50263  
[Map It](#)

**Phone**

(515) 314-2930

**Email**

[akp099@gmail.com](mailto:akp099@gmail.com)

**I am interested in serving on the following board(s) / commission(s) - Please refer to the notes above for the latest openings.**

- Historic Preservation Commission

**How did you hear about the opening(s)?**

- Other

**What relevant experience do you have that you think would be helpful in performing the duties on the Board/Commission?**

First, I hold more than twenty years experience in research and planning. It looks like both of these skills were leveraged in recent initiatives by the historic preservation commission and I would expect them to be helpful in the future.  
Second, I received a master's degree in Economics from Iowa State University and believe that expertise could be valuable to the commission. Finally, I have experience in grant review from my time working on the Blue Zones Project in Iowa. I think this experience could provide value if we apply for grants in the future. I also have responded to request for proposals (RFP) at my previous employer so have experience in both winning bids (RFP side) and rewarding money (grant review side)

**Briefly describe why you are interested in serving on the Board/Commission:**

Part of what attracted me to move to Adel was the historic preservation that has been done to date in the city and I would like to be part of preserving the city for future generations. I grew up in a house in Des Moines still owned by my family that was built at the turn of the 19th century and we have sought to preserve the original architecture of that house as it's been renovated. My maternal cousins own the only original cottage still on Lake Minnetonka in Minnesota (Thompson cottage). All of the other houses have been destroyed or torn down and so much of that history has been lost. It's inspiring to see how my family has preserved that house and gotten funding to assist with preservation. It is on a historic registry. It's also sad to see how much has been lost with no eye towards community preservation in the past for

the lake area.

I'd like to be part of the effort to preserve Adel's history while helping ensure buildings and infrastructure (like brick roads) are maintained and still useful to residents.

**Other comments and/or information:**

I have lived in Dallas County for over twenty years. We close on our house in Adel on or around June 18th. I am very open to meeting with Mayor, City Council, or members of commission to discuss this request and what I might be able to offer the commission. I am a very fast learner so could get up to speed quickly. Thank you for your consideration.

On a separate note I have reviewed a sampling of the work done by the commission and it is impressive. Thank you for your volunteer time.

**Signature**

Anna Kincaid Phelps



**AGENDA ITEM NO. 6.b**  
**AGENDA SECTION: NEW**  
**BUSINESS**

## **ADEL CITY COUNCIL AGENDA ITEM REPORT**

**MEETING DATE:** July 9, 2024

**TO:** Mayor & City Council

**FROM:** Carrie Erickson, City Clerk

**AGENDA HEADING:** Consider Approval of Resolution No. 24-41, Approving a 28E Agreement for Animal Shelter Services Between the City of Adel and AHeinz57 Pet Rescue and Transport, Inc.

### **STAFF/COMMITTEE RECOMMENDATION:**

The previous 28E Agreement between AHeinz and the City of Adel was entered into on July 13, 2021 and the term of that agreement ends on July 13, 2024. Through discussions with City staff and AHeinz staff a new agreement has been drafted with a few changes to the terms:

- The duration of this updated agreement is one year
- Cats were taken out as animals that the City is willing to deliver to AHeinz
- The quarantine period as adjusted to match Chapter 55 in the Adel City Code of Ordinances

**City Staff recommends approval.**

### **ATTACHMENTS:**

[Resolution No. 24-41, Approving 28E with AHeinz57 for Animal Shelter Services.pdf](#)  
[2024 Adel - Heinz57 28E Agreement \(with notes\).pdf](#)  
[2024 Adel - Heinz57 28E Agreement.pdf](#)

**Resolution No. 24-41**

**A RESOLUTION APPROVING A 28E AGREEMENT FOR ANIMAL SHELTER SERVICES BETWEEN THE CITY OF ADEL AND AHEINZ57 PET RESCUE AND TRANSPORT, INC.**

**WHEREAS**, the City of Adel desires to contract out animal shelter services in conjunction with the City’s Animal Control; and

**WHEREAS**, AHeinz57 Pet Rescue and Transport, Inc., an Iowa nonprofit corporation located in De Soto, IA, has agreed to provide the City these services under the attached agreement for an initial period of one year.

**NOW THEREFORE, IT IS HEREBY RESOLVED BY THE CITY COUNCIL OF THE CITY OF ADEL, IOWA**, that the City of Adel, Iowa desires to approve the 28E agreement for animal shelter services with AHeinz57 Pet Rescue and Transport, Inc. according to the terms of the attached agreement.

Passed and approved this 9<sup>th</sup> day of July, 2024

\_\_\_\_\_  
James F. Peters, Mayor

Attest: \_\_\_\_\_  
Carrie Erickson, City Clerk

**CHAPTER 28E AGREEMENT BETWEEN THE CITY OF ADEL, IOWA AND  
AHEINZ57 PET RESCUE AND TRANSPORT, INC. FOR ANIMAL SHELTER  
SERVICES**

This Agreement is made and entered into as of the ~~13<sup>th</sup> day of July, 2021~~ day of July, 2024, by and between the City of Adel ("the City"), located at 301 S. 10<sup>th</sup> Street, Adel, IA 50003, and AHeinz57 Pet Rescue and Transport, Inc. ("AHeinz57") an Iowa nonprofit corporation located at 4002 Ash Street, De Soto, IA 50069.

In accord with Chapter 28E and other relevant sections of the Code of Iowa, AHeinz57 and the City enter into the following agreement regarding animal shelter services in conjunction with City Animal Control.

**SECTION 1 - PARTIES**

- 1.1 AHeinz57 ~~Pet Reseue and Transport, Inc.~~ ("AHeinz57") is a non-profit, charitable organization and has authority to enter into this Agreement. ~~The~~ AHeinz57 is dedicated to helping care for homeless animals while providing rewarding programs for interim foster care, permanent adoption and volunteers to assist with community humanitarian efforts.
- 1.2 The City ~~of Adel, Iowa~~ is an Iowa municipal corporation and is a political subdivision of the State of Iowa, and has the authority to enter into this Agreement.

**SECTION 2 - PURPOSE**

Under this Agreement, AHeinz57 will provide animal shelter, care and impoundment services to the City ~~of Adel, Iowa~~, including impoundment which the City may be required to provide pursuant to certain of its ordinances, ordinances of municipalities with which the City contracts, or state law. This Agreement is a voluntary undertaking of the Parties. It is not the intention of the Parties to create a new legal entity. No real or personal property shall be acquired, held, or disposed of pursuant to this joint or cooperative undertaking.

**SECTION 3 - DEFINITIONS**

- 3.1 "Animal" shall mean nonhuman vertebrate.
- 3.2 "Bite Animal" shall mean an animal that has bitten a human, provided that the bite punctured the skin, without provocation.
- ~~3.3 "Cat" shall mean an animal fitting the scientific description of *felis catus*.~~
- 3.4 "Companion Animal" shall mean any animal owned, confined, controlled, or otherwise kept as a pet, but shall not include any livestock as defined under Iowa Code § 717.1, or any game, fur-bearing animal, fish, reptile, or amphibian as defined under Iowa Code § 481A.1.

- 3.5 "Dog" shall mean an animal fitting the scientific description *canis lupus familiaris*.
- 3.6 "Euthanasia" shall have the same meaning as defined under Iowa Code § 162.2(13).
- 3.7 "Parties" shall mean both AHeinz57 ~~Pet Rescue and Transport, Inc.~~ and the City ~~of Adel, Iowa.~~
- 3.8 "Livestock" shall mean an animal belonging to the bovine, caprine, equine, ovine, or porcine species, ostriches, rheas, emus, farm deer as defined in Iowa Code § 170.1, or poultry.
- 3.9 "Shelter Services" shall mean providing adequate nutrition, water, shelter, and medical treatment to animals under the care of AHeinz57.

SECTION 4 - TERMS

- 4.1 Animal Shelter Services Provided by AHeinz57: AHeinz57 agrees to do and perform the following:
  - (1) *Dog ~~and Cat~~ Shelter Services*. AHeinz57 shall provide Shelter Services to dogs ~~and cats~~ delivered to its shelter location by the City;
  - (2) *Other Animal Shelter Services*. AHeinz57 shall provide Shelter Services to other species of animals, including Bite Animals, but only if AHeinz57 has proper accommodations and is properly licensed for that species;
  - (3) *Holding Period & Automatic Transfer of Ownership*. Unless the City instructs otherwise, AHeinz57 shall retain animals brought to AHeinz57 by the City for ~~seven (7)~~ five (5) days, or longer if so required by any state, county, or municipal law, ordinance, rule or regulation applicable in the geographic area in which the animal was seized (hereinafter referred to as the "Holding Period"). Once the Holding Period expires, the City shall transfer ownership of the animal to AHeinz57. This paragraph does not apply to "Bite Animals";
  - (4) *Rabies Vaccination*. Upon reclaim of a Dog ~~or Cat~~, AHeinz57 shall require the redeeming party to produce a current and valid rabies vaccination certificate for the Dog ~~or Cat~~. If the owner fails to do so, AHeinz57 shall administer a rabies vaccination and charge the owner the rabies vaccination fee established by AHeinz57;
  - (5) *Attempt to Identify and Notify Owner*. Upon receipt of an animal delivery by the City and/or AHeinz57 staff, AHeinz57 shall first attempt to identify the owner of the animal and notify the owner, if found, of the seizure of the animal as well as the owner's right to redeem the animal;

- (6) *Redemption of Impounded Animal by Owner.* The owner of an animal impounded at AHeinz57 shall have the right to redeem that animal, subject to the following conditions:
- i. *City-Issued Release.* AHeinz57 shall require the redeeming owner to present a completed City of Adel release;
  - ii. *Boarding Fees and other costs.* AHeinz57 shall charge and collect any incurred boarding, veterinarian, vaccination or other fees directly from the owner prior to releasing the animal;
- (7) *Bite Animal Quarantine.* Upon receipt of a Bite Animal, AHeinz57 shall keep the Bite Animal under quarantine for ~~ten (10)~~ a minimum of five (5) days. During that period, AHeinz57 shall observe the Bite Animal for symptoms of rabies and other infectious diseases. Quarantined Bite Animals shall be released or euthanized only as directed by the City.
- (8) *Humane Euthanasia.* For reasons of public safety, to relieve animal suffering or to address highly contagious diseases and only after consultation with AHeinz57 staff veterinarians and AHeinz57 behavioral staff, AHeinz57 may humanely euthanize unclaimed, non-adopted animals. Additionally, AHeinz57 shall humanely euthanize animals if ordered to do so by the City. Further any and all euthanasia procedures performed by AHeinz57 staff shall be done in accordance with Iowa Code § 162.2(13);
- (9) *Emergency Veterinarian Services.* During regular business hours (Monday through Friday, 8:00 a.m. to 5:00 p.m., excluding holidays), AHeinz57 shall provide the services of a licensed veterinarian when, after consultation with the City, such services appear necessary in an emergency. Outside regular business hours, however, the City shall deliver any animals requiring emergency veterinarian services to a 24-hour animal hospital;
- (10) *Receipt of Dead Animals.* AHeinz57 shall accept dead dogs/puppies and cats/kittens of any size, and other animals not exceeding forty (40) pounds in weight, for cremation and/or other appropriate disposal;
- (11) *After-Hours Delivery Cages.* AHeinz57 shall have available two (2) clean, secure, and lockable canine cages ~~and two (2) clean, secure, and lockable feline cages with litter boxes~~ for after-hours deliveries, all of which are supplied with fresh water;
- 4.2 City Animal Service Fee. In consideration for animal services provided by AHeinz57 the City shall pay AHeinz57 a fee of \$50.00 per animal delivered by ~~the City~~ City staff, including police officers, to AHeinz57.
- 4.3 Records Access. AHeinz57 shall keep intake information of strays from the City. AHeinz57 shall make such intake information available to the City upon request. However,

the City shall not release any information about AHeinz57, its donors, adopters, or any information the City may be privy to as a result of the Agreement, to any person or persons, or other entities without the prior written consent of the Executive Director of AHeinz57 with the exception of records that are public records under Iowa Code Chapter 22, which may include this Agreement.

- 4.4 Licenses and Compliance. AHeinz57 shall apply for, and maintain, all necessary and/or applicable licenses, certifications and inspections relevant to current health, fire, safety, and professional standards. AHeinz57 must immediately correct any deficiencies or violations or take immediate action to seek variances. AHeinz57 shall comply with all other applicable state, federal and local laws, ordinances, rules and regulations. Further AHeinz57 shall not deny, restrict access to, or provide inferior services to any person, or deny or restrict employment opportunities, including promotional opportunities, to any applicant or current employee, on the basis of sex, age, race, national origin, religion, sexual orientation, gender identity, or physical or mental disability.
- 4.5 Insurance. AHeinz57 shall acquire and retain throughout the term of this Agreement suitable and sufficient insurance, and fidelity bonding, so as to protect it, its entire staff including contract employees, its clients, the City and the general public against any loss, injury, damage, or other liability arising from any wrongful or negligent act or omission in connection with responsibilities assumed by AHeinz57 under the terms of this Agreement.

AHeinz57 shall possess the following minimum insurance coverage during the term of this Agreement: Commercial General Liability - \$1,000,000.00 per occurrence and \$2,000,000.00 general aggregate; Medical Expenses (any one person) - \$5,000.00; Workers' Compensation - Statutory, as required by the State of Iowa; Employer's Liability - \$500,000.00 bodily injury per accident, \$500,000.00 by disease, policy limit, and \$500,000.00 by disease, each employee; Excess / Umbrella Liability - \$1,000,000.00 per occurrence and annual aggregate limit. The City shall be named as "Additional Insured" on the Commercial General Liability and Excess / Umbrella Liability insurance policies, using the following language: "City of Adel, Iowa, its Elected Officials, Employees, Agents, and Assigns."

AHeinz57 shall annually send an updated Certificate of Insurance to the City for verification. The Certificate of Insurance shall identify the following: The insurance company firm name and address; AHeinz57's business name and address; insurance policy(s) number(s); policy period; type of policy and coverage; limits of coverage; description of operations covered; certificate holder/"Additional Insured"; and cancellation clause. AHeinz57 shall not cancel or lessen coverage limits on any insurance policies in existence without first providing thirty (30) calendar days advanced written notice to the City. The Parties expressly agree and state that the purchase of this policy of insurance does not provide coverage for torts specified in Iowa Code § 670.4, and the City does not waive any of the defenses of governmental immunity available to the City under Iowa Code § 670.4 as it now exists and as it may be amended from time to time. The Parties further expressly agree and state that the City may, at any time, assert any of the governmental immunity defenses available to it without affecting the coverage afforded under this policy.

Any insurance policies listing the City as an "Additional Insured" must contain an endorsement with the above language related to any defenses of governmental immunity.

4.6 Indemnification. The Parties shall indemnify and hold each other harmless against actions, liabilities, loss, damages and expenses resulting from injury or death of any person or loss of or damage to any tangible real or personal property to the extent that such injury, death, loss or damage relates to or arises from:

- (1) Any violation of this Agreement by either party;
- (2) Any negligent acts or omissions of the Parties, their officers, employees, agents, board members, contractors or any other person in connection with this Agreement;
- (3) The Parties performance of their respective duties under this Agreement;
- (4) Any failure by the Parties to comply with all local, state and federal laws and regulations; and/or
- (5) Any damage to property, real, personal, or other, by the dogs ~~and cats~~, including property of the staff, contractor, and/or third parties, which is not attributable to negligence on the part of either party.

4.7 Duration and Termination. This Agreement shall be effective ~~July 13, 2021~~ July 13, 2024 through ~~July 13, 2024~~ July 13, 2025. The parties may agree to extend the term of this Agreement at any time in writing. Further either party may choose to terminate this Agreement for any reason and at any time ~~by either party upon~~ by providing the other party at least one hundred and eighty (180) days prior written notice. Such notice, or any other notice required or permitted to be given hereunder, shall be addressed as follows:

If to AHeinz57  
Executive Director  
4002 Ash Street  
De Soto, IA 50069

If to the City:  
City Administrator  
301 S. 10<sup>th</sup> Street  
Adel, IA 50003

Or to such other address as either party shall have notified the other party of, in writing. Notice shall be deemed given when deposited with the U.S. Postal Services, registered or certified, addressed as specified.

4.8 Independent Contractor. Aheinz57 is an independent contractor and in no event or circumstance are any employees of Aheinz57 to be considered employees or agents of the City, or to receive any benefits from the City. Employees hired and volunteers acquired by

Formatted: Highlight

AHeinz57 to perform any and all of AHeinz57's obligations related to this Agreement shall be paid or compensated by AHeinz57 in accordance with the laws of the State of Iowa. AHeinz57 shall also provide workers' compensation and other statutory benefits to comply with applicable state and federal laws.

4.9 This Agreement shall be administered on behalf of the City by the Adel Chief of Police or designee. The Agreement shall be administered on behalf of AHeinz57, and services provided for hereunder shall be controlled and supervised by, the Executive Director of AHeinz57. Upon approval by each party to this Agreement, this Agreement shall be electronically filed by the City with the Secretary of State, pursuant to Iowa Code § 28E.8.

IN WITNESS THEREOF, this Agreement has been executed to be effective as set forth above.

**CITY OF ADEL, IOWA**

**AHEINZ57 PET RESCUE AND TRANSPORT,  
INC.**

By: \_\_\_\_\_  
James F. Peters, Mayor

By: \_\_\_\_\_  
Amy Heinz, Executive Director

Attest: \_\_\_\_\_  
[Carrie Erickson](#), City Clerk

**CHAPTER 28E AGREEMENT BETWEEN THE CITY OF ADEL, IOWA AND  
AHEINZ57 PET RESCUE AND TRANSPORT, INC. FOR ANIMAL SHELTER  
SERVICES**

This Agreement is made and entered into as of the \_\_\_\_ day of July, 2024, by and between the City of Adel ("the City"), located at 301 S. 10<sup>th</sup> Street, Adel, IA 50003, and AHeinz57 Pet Rescue and Transport, Inc. ("AHeinz57") an Iowa nonprofit corporation located at 4002 Ash Street, De Soto, IA 50069.

In accord with Chapter 28E and other relevant sections of the Code of Iowa, AHeinz57 and the City enter into the following agreement regarding animal shelter services in conjunction with City Animal Control.

**SECTION 1 - PARTIES**

- 1.1 AHeinz57 is a non-profit, charitable organization and has authority to enter into this Agreement. AHeinz57 is dedicated to helping care for homeless animals while providing rewarding programs for interim foster care, permanent adoption and volunteers to assist with community humanitarian efforts.
- 1.2 The City is an Iowa municipal corporation and is a political subdivision of the State of Iowa, and has the authority to enter into this Agreement.

**SECTION 2 - PURPOSE**

Under this Agreement, AHeinz57 will provide animal shelter, care and impoundment services to the City, including impoundment which the City may be required to provide pursuant to certain of its ordinances, ordinances of municipalities with which the City contracts, or state law. This Agreement is a voluntary undertaking of the Parties. It is not the intention of the Parties to create a new legal entity. No real or personal property shall be acquired, held, or disposed of pursuant to this joint or cooperative undertaking.

**SECTION 3 - DEFINITIONS**

- 3.1 "Animal" shall mean nonhuman vertebrate.
- 3.2 "Bite Animal" shall mean an animal that has bitten a human, provided that the bite punctured the skin, without provocation.
3. "Companion Animal" shall mean any animal owned, confined, controlled, or otherwise kept as a pet, but shall not include any livestock as defined under Iowa Code § 717.1, or any game, fur-bearing animal, fish, reptile, or amphibian as defined under Iowa Code § 481A.1.
- 3.5 "Dog" shall mean an animal fitting the scientific description *canis lupus familiaris*.

- 3.6 "Euthanasia" shall have the same meaning as defined under Iowa Code § 162.2(13).
- 3.7 "Parties" shall mean both AHeinz57 and the City.
- 3.8 "Livestock" shall mean an animal belonging to the bovine, caprine, equine, ovine, or porcine species, ostriches, rheas, emus, farm deer as defined in Iowa Code § 170.1, or poultry.
- 3.9 "Shelter Services" shall mean providing adequate nutrition, water, shelter, and medical treatment to animals under the care of AHeinz57.

#### SECTION 4 - TERMS

- 4.1 Animal Shelter Services Provided by AHeinz57: AHeinz57 agrees to do and perform the following:
- (1) *Dog Shelter Services*. AHeinz57 shall provide Shelter Services to dogs delivered to its shelter location by the City;
  - (2) *Other Animal Shelter Services*. AHeinz57 shall provide Shelter Services to other species of animals, including Bite Animals, but only if AHeinz57 has proper accommodations and is properly licensed for that species;
  - (3) *Holding Period & Automatic Transfer of Ownership*. Unless the City instructs otherwise, AHeinz57 shall retain animals brought to AHeinz57 by the City for five (5) days, or longer if so required by any state, county, or municipal law, ordinance, rule or regulation applicable in the geographic area in which the animal was seized (hereinafter referred to as the "Holding Period"). Once the Holding Period expires, the City shall transfer ownership of the animal to AHeinz57. This paragraph does not apply to "Bite Animals";
  - (4) *Rabies Vaccination*. Upon reclaim of a Dog, AHeinz57 shall require the redeeming party to produce a current and valid rabies vaccination certificate for the Dog. If the owner fails to do so, AHeinz57 shall administer a rabies vaccination and charge the owner the rabies vaccination fee established by AHeinz57;
  - (5) *Attempt to Identify and Notify Owner*. Upon receipt of an animal delivery by the City and/or AHeinz57 staff, AHeinz57 shall first attempt to identify the owner of the animal and notify the owner, if found, of the seizure of the animal as well as the owner's right to redeem the animal;
  - (6) *Redemption of Impounded Animal by Owner*. The owner of an animal impounded at AHeinz57 shall have the right to redeem that animal, subject to the following conditions:

- i. *City-Issued Release.* AHeinz57 shall require the redeeming owner to present a completed City of Adel release;
    - ii. *Boarding Fees and other costs.* AHeinz57 shall charge and collect any incurred boarding, veterinarian, vaccination or other fees directly from the owner prior to releasing the animal;
  - (7) *Bite Animal Quarantine.* Upon receipt of a Bite Animal, AHeinz57 shall keep the Bite Animal under quarantine for a minimum of five (5) days. During that period, AHeinz57 shall observe the Bite Animal for symptoms of rabies and other infectious diseases. Quarantined Bite Animals shall be released or euthanized only as directed by the City.
  - (8) *Humane Euthanasia.* For reasons of public safety, to relieve animal suffering or to address highly contagious diseases and only after consultation with AHeinz57 staff veterinarians and AHeinz57 behavioral staff, AHeinz57 may humanely euthanize unclaimed, non-adopted animals. Additionally, AHeinz57 shall humanely euthanize animals if ordered to do so by the City. Further any and all euthanasia procedures performed by AHeinz57 staff shall be done in accordance with Iowa Code § 162.2(13);
  - (9) *Emergency Veterinarian Services.* During regular business hours (Monday through Friday, 8:00 a.m. to 5:00 p.m., excluding holidays), AHeinz57 shall provide the services of a licensed veterinarian when, after consultation with the City, such services appear necessary in an emergency. Outside regular business hours, however, the City shall deliver any animals requiring emergency veterinarian services to a 24-hour animal hospital;
  - (10) *Receipt of Dead Animals.* AHeinz57 shall accept dead dogs/puppies and cats/kittens of any size, and other animals not exceeding forty (40) pounds in weight, for cremation and/or other appropriate disposal;
  - (11) *After-Hours Delivery Cages.* AHeinz57 shall have available two (2) clean, secure, and lockable canine cages for after-hours deliveries, all of which are supplied with fresh water;
- 4.2 City Animal Service Fee. In consideration for animal services provided by AHeinz57 the City shall pay AHeinz57 a fee of \$50.00 per animal delivered by City staff, including police officers, to AHeinz57.
- 4.3 Records Access. AHeinz57 shall keep intake information of strays from the City. AHeinz57 shall make such intake information available to the City upon request. However, the City shall not release any information about AHeinz57, its donors, adopters, or any information the City may be privy to as a result of the Agreement, to any person or persons, or other entities without the prior written consent of the Executive Director of AHeinz57

with the exception of records that are public records under Iowa Code Chapter 22, which may include this Agreement.

- 4.4 Licenses and Compliance. AHeinz57 shall apply for, and maintain, all necessary and/or applicable licenses, certifications and inspections relevant to current health, fire, safety, and professional standards. AHeinz57 must immediately correct any deficiencies or violations or take immediate action to seek variances. AHeinz57 shall comply with all other applicable state, federal and local laws, ordinances, rules and regulations. Further AHeinz57 shall not deny, restrict access to, or provide inferior services to any person, or deny or restrict employment opportunities, including promotional opportunities, to any applicant or current employee, on the basis of sex, age, race, national origin, religion, sexual orientation, gender identity, or physical or mental disability.
- 4.5 Insurance. AHeinz57 shall acquire and retain throughout the term of this Agreement suitable and sufficient insurance, and fidelity bonding, so as to protect it, its entire staff including contract employees, its clients, the City and the general public against any loss, injury, damage, or other liability arising from any wrongful or negligent act or omission in connection with responsibilities assumed by AHeinz57 under the terms of this Agreement.

AHeinz57 shall possess the following minimum insurance coverage during the term of this Agreement: Commercial General Liability - \$1,000,000.00 per occurrence and \$2,000,000.00 general aggregate; Medical Expenses (any one person) - \$5,000.00; Workers' Compensation - Statutory, as required by the State of Iowa; Employer's Liability - \$500,000.00 bodily injury per accident, \$500,000.00 by disease, policy limit, and \$500,000.00 by disease, each employee; Excess / Umbrella Liability - \$1,000,000.00 per occurrence and annual aggregate limit. The City shall be named as "Additional Insured" on the Commercial General Liability and Excess / Umbrella Liability insurance policies, using the following language: "City of Adel, Iowa, its Elected Officials, Employees, Agents, and Assigns."

AHeinz57 shall annually send an updated Certificate of Insurance to the City for verification. The Certificate of Insurance shall identify the following: The insurance company firm name and address; AHeinz57's business name and address; insurance policy(s) number(s); policy period; type of policy and coverage; limits of coverage; description of operations covered; certificate holder/"Additional Insured"; and cancellation clause. AHeinz57 shall not cancel or lessen coverage limits on any insurance policies in existence without first providing thirty (30) calendar days advanced written notice to the City. The Parties expressly agree and state that the purchase of this policy of insurance does not provide coverage for torts specified in Iowa Code § 670.4, and the City does not waive any of the defenses of governmental immunity available to the City under Iowa Code § 670.4 as it now exists and as it may be amended from time to time. The Parties further expressly agree and state that the City may, at any time, assert any of the governmental immunity defenses available to it without affecting the coverage afforded under this policy. Any insurance policies listing the City as an "Additional Insured" must contain an endorsement with the above language related to any defenses of governmental immunity.

4.6 Indemnification. The Parties shall indemnify and hold each other harmless against actions, liabilities, loss, damages and expenses resulting from injury or death of any person or loss of or damage to any tangible real or personal property to the extent that such injury, death, loss or damage relates to or arises from:

- (1) Any violation of this Agreement by either party;
- (2) Any negligent acts or omissions of the Parties, their officers, employees, agents, board members, contractors or any other person in connection with this Agreement;
- (3) The Parties performance of their respective duties under this Agreement;
- (4) Any failure by the Parties to comply with all local, state and federal laws and regulations; and/or
- (5) Any damage to property, real, personal, or other, by the dogs, including property of the staff, contractor, and/or third parties, which is not attributable to negligence on the part of either party.

4.7 Duration and Termination. This Agreement shall be effective July 13, 2024 through July 13, 2025. The parties may agree to extend the term of this Agreement at any time in writing. Further either party may choose to terminate this Agreement for any reason and at any time by providing the other party at least one hundred and eighty (180) days prior written notice. Such notice, or any other notice required or permitted to be given hereunder, shall be addressed as follows:

If to AHeinz57  
Executive Director  
4002 Ash Street  
De Soto, IA 50069

If to the City:  
City Administrator  
301 S. 10<sup>th</sup> Street  
Adel, IA 50003

Or to such other address as either party shall have notified the other party of, in writing. Notice shall be deemed given when deposited with the U.S. Postal Services, registered or certified, addressed as specified.

4.8 Independent Contractor. Aheinz57 is an independent contractor and in no event or circumstance are any employees of Aheinz57 to be considered employees or agents of the City, or to receive any benefits from the City. Employees hired and volunteers acquired by AHeinz57 to perform any and all of AHeinz57's obligations related to this Agreement shall be paid or compensated by AHeinz57 in accordance with the laws of the State of Iowa.

AHeinz57 shall also provide workers' compensation and other statutory benefits to comply with applicable state and federal laws.

- 4.9 This Agreement shall be administered on behalf of the City by the Adel Chief of Police or designee. The Agreement shall be administered on behalf of AHeinz57, and services provided for hereunder shall be controlled and supervised by, the Executive Director of AHeinz57. Upon approval by each party to this Agreement, this Agreement shall be electronically filed by the City with the Secretary of State, pursuant to Iowa Code § 28E.8.

IN WITNESS THEREOF, this Agreement has been executed to be effective as set forth above.

**CITY OF ADEL, IOWA**

**AHEINZ57 PET RESCUE AND TRANSPORT,  
INC.**

By: \_\_\_\_\_  
James F. Peters, Mayor

By: \_\_\_\_\_  
Amy Heinz, Executive Director

Attest: \_\_\_\_\_  
Carrie Erickson, City Clerk



**AGENDA ITEM NO. 6.c**  
**AGENDA SECTION: NEW**  
**BUSINESS**

## **ADEL CITY COUNCIL AGENDA ITEM REPORT**

**MEETING DATE:** July 9, 2024

**TO:** Mayor & City Council

**FROM:** Carrie Erickson, City Clerk

**AGENDA HEADING:** Consider Approval of Revised Live Trap Policy - Policy #5.05.01

**STAFF/COMMITTEE RECOMMENDATION:**

In accordance with the 28E agreement between the City of Adel and AHeinz57 Pet Rescue and Transportation considered earlier in the meeting, the live trap policy for the City needs to be updated to reflect the correct fee for impounding domesticated dogs.

Other updates were made considering the change of animal rescue service being utilized by the City of Adel.

**City Staff is recommending approval.**

**ATTACHMENTS:**

[5.05.01 Live Trap Loan Policy - 07.09.2024 Update.pdf](#)

---

---

**City of Adel**  
**Manual of Policy and Procedure**

---

---

**Section:** 5. Public Works and Utilities

**Title:** Live Trap Loan Policy

<b>Effective Date: (Revisions)</b>	November 8, 2011 – Council Approval	<b>Resolution No.</b>	N/A
	November 12, 2013 – Council Approval		N/A
	March 8, 2016 – Council Approval		
	<u>July 9, 2024 – Council Approval</u>		

**Policy Number:** 5.05.01

---

---

**1. PURPOSE**

Live Traps are rented out by the City of Adel to residents who need to trap wild or domestic animals, which pose a nuisance to their property.

\*\*\* City of Adel will not accept responsibility for animals caught in a non-city trap. \*\*\*

**2. POLICY AND PROCEDURE**

- A. Requests for a live trap can be made by residents of Adel at City Hall - either in person, or by phone or email.
- B. If a trap is not available at the time of request, the name of the resident shall be placed on a waiting list along with their telephone number and date the request was made.

**3. RENTING OF LIVE TRAP**

- A. When a trap is available, the resident shall pay a rental fee of \$15.00 and ~~a \$an \$80.00~~ deposit at the time the trap is picked up at City Hall. City staff shall instruct resident how to set trap.
- B. The \$80.00 deposit will be refunded upon the return of the trap.
- C. A receipt will be issued from City Hall that will need to be presented to the on-duty officer or public works personnel who comes to pick up the trapped animal.
- D. City Hall will notify the Police Chief and Police Secretary when a live trap has been rented out with the following information of the resident: Name, Address, Phone Number, and Live Trap Number.

**4. TIME LIMIT**

- A. Live traps shall be rented for only 1 week at a time. If after that time, the user wishes to keep it another week, they must call City Hall. If there are names on the waiting list, the trap shall go to the next person on the list. If there are no names on the waiting list, the user can keep it for an additional week.

B. If after two weeks, the resident has not contacted City Hall, the City Clerk will try to contact the resident and ask them to return the trap. If after one more week, the resident still has not returned the trap then the \$80.00 deposit will be forfeited and non-refundable.

Formatted: Font: 12 pt

Formatted: Normal, No bullets or numbering

~~B.~~

## 5. RETURN OF LIVE TRAP

- A. Upon capture of an animal, the user shall call The Police Department at 515-993-6723 and an on-duty police officer will retrieve the trap and animal. If the on-duty officer is not available, a Public Works personnel at 515-993-4525 may assist Monday through Friday, 8:30 a.m. to 3:30 p.m. only.
- B. Wild animals will be released outside of city limits. Domesticated ~~dogs~~ animals will be taken to the AHeinz 57 Pet Rescue & Transport ~~Adel Veterinary Clinic~~ where owners, if known, will be contacted.
- C. An incident report will be completed on all ~~domesticated dog~~ trapped animals brought into AHeinz the Vet Clinic by the Police Department or Public Works personnel.
- D. Any domesticated dogs that are trapped ~~The trapped animal~~ will be taken to the City Shed if AHeinz the Vet Clinic's office is not opened, until such time that Public Works personnel can transport the ~~animal dog~~ to AHeinz the Vet Clinic.
- E. A ~~\$50.00~~ \$25.00 impound fee must be paid at City Hall before AHeinz the Vet Clinic is allowed to release the ~~domesticated dog to their owner~~ trapped animal.



**AGENDA ITEM NO. 6.d**  
**AGENDA SECTION: NEW**  
**BUSINESS**

## **ADEL CITY COUNCIL AGENDA ITEM REPORT**

**MEETING DATE:** July 9, 2024

**TO:** Mayor & City Council

**FROM:** Carrie Erickson, City Clerk

**AGENDA HEADING:** Consider Approval of Ordinance No. 409, Amending Chapter 55, Animal Protection and Control For the Purpose of Removing References to Animal Licenses and To Increase the Administrative Impound Fee - First Reading

### **STAFF/COMMITTEE RECOMMENDATION:**

This ordinance refers to repealing references to animal licenses in Chapter 55. This ordinance also updates information about fees associated with impounding animals. The specific amount of the fee was stated previously and it has been updated to say, "The administrative fee shall be established by resolution of the Council."

**City Staff is recommending approval.**

### **ATTACHMENTS:**

[Ordinance No. 409, Amending Ch. 55, Animal Control.pdf](#)

**ORDINANCE NO. 409**

**AN ORDINANCE AMENDING CHAPTER 55, ANIMAL PROTECTION AND CONTROL, OF THE CODE OF ORDINANCES FOR THE CITY OF ADEL FOR THE PURPOSE OF REMOVING REFERENCES TO ANIMAL LICENSES FROM THE CITY CODE AND TO INCREASE THE ADMINISTRATIVE IMPOUND FEE**

**NOW, THEREFORE, BE IT ORDAINED BY THE CITY COUNCIL OF THE CITY OF ADEL, IOWA, THAT:**

**SECTION ONE.** Sections 55.09(6) and (7) of the municipal code are hereby repealed and replaced with Section 55.09(6) as follows:

**55.09. VICIOUS DOGS.**

...

6. Appeal Procedures.

A. Appeal of Vicious Dog Determination.

(1) Any person who receives an order from the Chief of Police determining that their dog is a vicious dog may appeal the order by filing a written notice of appeal to the City Administrator within five days of the date of the order. The written appeal shall state the grounds of the appeal.

(2) Upon receiving a notice of appeal, a hearing shall be convened, chaired by the City Administrator or designee, to receive any testimony or other evidence that is deemed appropriate concerning the determination that a dog is a vicious dog.

(3) When an appeal has been filed, the Chief of Police shall make a reasonable effort to notify any persons who would have had direct involvement in the situation which led to the vicious dog determination, including those persons who were injured or who are owners or keepers of any animals which were injured by the vicious dog.

(4) The appeal shall be heard by a committee appointed by the City Administrator and consisting of a minimum of three people, including the City Administrator, a member of the public, and one of the following: an animal trainer, a veterinarian, or an animal control professional. Following such hearing, the committee may uphold the decision of the Chief of Police and order the vicious dog to be confined as required by the City Code; or modify or reverse the decision of the Chief of Police. The decision and the reasons for it shall be summarized in writing and provided to the person who filed the appeal.

B. Appeal of Euthanasia Order.

(1) A person who received an order from the Chief of Police requiring that a vicious dog be removed and humanely destroyed as provided in Section 55.09(5) may appeal the order by filing a written notice of appeal to the City Administrator within five days of the date of the order. The written appeal shall state the grounds of the appeal, including how the person proposes to keep the vicious dog in a manner that is in compliance with the standards set out in this chapter, and how the person proposes to reduce the risk of harm that the vicious dog poses to the public.

(2) Upon receiving a notice of appeal, a hearing shall be convened, chaired by the City Administrator or designee, to receive any testimony or other evidence that is deemed appropriate concerning the order that the dog be destroyed.

(3) When an appeal has been filed, the Chief of Police shall make a reasonable effort to notify any persons who would have had direct involvement in the situation which led to the order that the dog be destroyed, including those persons who were injured or who are owners or keepers of any animals which were injured by the vicious dog.

(4) The appeal shall be heard by a committee appointed by the City Administrator and consisting of a minimum of three people, including the City Administrator, a member of the public, and one of the following: an animal trainer, a veterinarian, or an animal control professional. Following such hearing, the committee may uphold the decision of the Chief of Police and order the vicious dog to be destroyed; or modify or reverse the decision of the Chief of Police. The decision and the reasons for it shall be summarized in writing and provided to the person who filed the appeal.

**SECTION TWO.** Section 55.12 of the municipal code is hereby repealed and replaced as follows:

**55.12 REDEMPTION OF IMPOUNDED ANIMALS.**

When an animal has been apprehended and impounded for being at large or for any other reason, said animal may be redeemed by the owner upon payment of an administrative fee plus those charges assessed by the clinic or shelter housing the animal. The administrative fee shall be established by resolution of the Council.

**SECTION THREE.** Section 55.14 of the municipal code is hereby repealed and replaced as follows:

**55.14 RIGHT TO KILL DOG OR CAT.**

It is lawful for any peace officer or designee of the Mayor to kill any dog or cat when such animal is attacking or attempting to bite a person.

**SECTION FOUR.** Severability. If any section, subsection, sentence, clause, phrase, or portion of this ordinance be held invalid or unconstitutional by any court of competent jurisdiction, such portion shall be deemed a separate, distinct and independent provision, and such holding shall not affect the validity of the remaining portion hereof.

**SECTION FIVE.** Repealer. All ordinances or parts of ordinances in conflict with the provisions of this ordinance are hereby repealed.

**SECTION SIX.** Effective. This Ordinance shall be in full force and effect, from and after its passage, adoption, and approval and publication as required by law, unless a subsequent effective date is set out hereinabove.

**SECTION SEVEN.** When this ordinance is in effect, it shall automatically supplement, amend, and become a part of the said Code of Ordinances of the City of Adel, Iowa.

First Reading Passed: \_\_\_\_\_

Second Reading Passed: \_\_\_\_\_

Third Reading Passed: \_\_\_\_\_

Passed and adopted this \_\_\_\_\_ day of \_\_\_\_\_, 2024.

\_\_\_\_\_  
James F. Peters, Mayor

ATTEST:

\_\_\_\_\_  
Carrie Erickson, City Clerk



**AGENDA ITEM NO. 6.e**  
**AGENDA SECTION: NEW**  
**BUSINESS**

## **ADEL CITY COUNCIL AGENDA ITEM REPORT**

**MEETING DATE:** July 9, 2024

**TO:** Mayor & City Council

**FROM:** Carrie Erickson, City Clerk

**AGENDA HEADING:** Consider Approval of Resolution No. 24-42, Setting the FY2024-2025 Fees for Services

**PREVIOUS COUNCIL ACTION:** The council approved Res. No. 24-08 updating the fees for the Adel Family Aquatic Center on February 13, 2024.  
The council approved Res. No. 24-35 updating the fees for the fiscal year 2024-2025 on May 14, 2024.

**STAFF/COMMITTEE RECOMMENDATION:**

This resolution considers approving updates to the City's Fee Schedule effective July 9, 2024.

The proposed schedule adds in the impound/animal at large fee of \$50.00 that matches the 28E agreement between City of Adel and AHeinz 57 Pet Rescue and Transportation terms for Animal Shelter Services. This \$50.00 matches the impound fee that AHeinz charges the City of Adel if an on-duty police officer drops off a domesticated dog at AHeinz.

This updated fee also matches the proposed Ordinance No. 409 considered earlier in this meeting.

**City staff is recommending approval.**

**ATTACHMENTS:**

[Resolution No. 24-42, FY24-25 Fee Schedule \(Impound Fee Update\).pdf](#)  
[July 9, 2024 City of Adel Fee Schedule \(with Notes\).pdf](#)

**Resolution No. 24-42**

**A RESOLUTION SETTING THE FY2024-2025 FEES FOR SERVICES**

**WHEREAS**, the Adel City Council has reviewed the proposed fees for services for Fiscal Year 2024-2025 (attached) and determined said fees are necessary and appropriate.

**NOW THEREFORE, IT IS HEREBY RESOLVED BY THE CITY COUNCIL OF THE CITY OF ADEL, IOWA**, that the fee schedule attached, titled City of Adel Fees for Services Effective July 9, 2024, be approved and shall be in effect beginning July 9, 2024.

Passed and approved this 9<sup>th</sup> day of July, 2024.

\_\_\_\_\_  
James F. Peters, Mayor

Attest: \_\_\_\_\_  
Carrie Erickson, City Clerk

# City of Adel Fees for Services

Effective July 19, 2024

## Utilities

**Please Note: The City's credit card processors charge additional fees for utility payments made online and over-the-phone. These fees are not set by the City and vary depending on the amount of the payment. The processing companies can change the fees at any time.**

### **Water:**

Minimum Monthly Charge: \$34.32

Every 1,000 gallons	\$17.16 per thousand
---------------------	----------------------

### **Sewer:** *(based on water usage)*

Minimum Monthly Charge: \$32.64

Every 1,000 gallons	\$16.32 per thousand
---------------------	----------------------

### **Waste, Recycling and Storm Water Fees:**

Residential Garbage (includes yard waste)	\$13.80/mo.
Residential Recycling	\$4.34/mo.
Storm Water	\$3.72 per ESU
CSWI <i>(on all accounts that have Storm Water utility charge)</i>	\$6.00

### **New Water & Sewer Hookup:**

Residential WA	\$800.00 + cost of meter
Commercial and Industrial WA	\$1000.00 + cost of meter
Residential Sewer Connection	\$800 + cost of deduct meter <i>(if applicable)</i>
Commercial and Industrial Sewer Connection	\$1000.00 + cost of deduct meter <i>(if applicable)</i>
East Annex Sanitary Sewer Connection	See schedule in Code Chapter 99A
Water Deposit	\$150.00
Garbage and Recycling Services Only Deposit	\$50.00
Disconnection Notice Tag Fee	\$30.00
Turn-on/Reconnection Fee	\$50.00
Temporary Service Shut-Off Fee	\$10.00
Restoring Service Fee <i>(after Temporary Shut-Off)</i>	\$10.00
Irrigation Meter (Plumbed In)	Cost of Meter
Water Meter Testing	\$100.00

*\*Residential size water meter provided.*

***Oversize meter:*** *additional charge of difference between residential and requested size.*

## **Public Works & Engineering Department**

### **Board of Adjustment:**

Residential	\$75.00
Non-Residential	\$125.00
Conditional Use Permit	\$125.00

# City of Adel Fees for Services

Effective July 19, 2024

## Zoning/Developer Fees:

Subdivision Maintenance Bond Inspection Fee	\$800.00
Warning / Outdoor Siren Fee	\$50.00 per lot
GIS Fee	\$25.00 per lot
District Re-Zoning Fee	\$250.00
Sub-division Fee	\$250.00 + Engineering Costs
Signage Fee	\$1.00/ft. of paving

## Permits:

Fence*	\$35.00
Sign	\$35.00
Basic Shed*	\$40.00 (120 sq. ft.)
Deck*	\$30.00 (Up to 100 sq. ft.); \$40.00 (100-200 sq. ft.); \$50.00 (>200 sq. ft.)

*\*May be waived for eligible veterans as a part of the Home Base Iowa program.*

## Building Permit Fees:

Total Valuation	Fee
\$1.00 to \$500.00	\$22.00
\$501.00 to \$2,000.00	\$22.00 for the first \$500.00 + \$2.75 for each add'l \$100.00
\$2,001.00 to \$25,000.00	\$75.50 for the first \$2,000.00 + \$12.50 for each add'l \$1,000.00
\$25,000.00 to \$50,000.00	\$361.00 for the first \$25,000.00 + \$9.00 for each add'l \$1,000.00
\$50,000.00 to \$100,000.00	\$586.25 for the first \$50,000.00 + \$6.25 for each add'l \$1,000.00
\$100,000.00 to \$500,000.00	\$900.00 for the first \$100,000.00 + \$5.00 for each add'l \$1,000.00
\$500,000.00 to \$1,000,000.00	\$2,900.00 for the first \$500,000.00 + \$4.25 for each add'l \$1,000.00
\$1,000,000.00 and up	\$5,023.50 for the first \$1,000,000.00 + \$2.75 for each add'l \$1,000.00
Re-Inspection Fees	\$42.00/hr. (1-hour minimum charge)

## Commercial Plan Review:

Site Review / Plan Check (Commercial)	65% of Total Building Permit Fee
---------------------------------------	----------------------------------

# City of Adel Fees for Services

Effective July 19, 2024

## Vacant Building Fees:

Registration (180-day Inspection Fee)	\$0.06/sq. ft.
Re-inspection Fees	\$0.06/sq. ft. based on violation only
Subsequent Annual Registration	\$0.06/sq. ft.

## Electrical Code:

Miscellaneous Electrical Fees (Residential)	\$40.00
---	---------

## Plumbing Code:

Miscellaneous Plumbing Fees (Residential)	\$40.00
Miscellaneous Plumbing Fees (Commercial)	\$50.00

## Rental Inspections:

Single Family	\$25.00 per unit
Multi-Family	\$25.00 for first unit and \$10.00 for all other units

## Police Department

### Miscellaneous:

Reports	\$5.00
Photos	\$5.00
CD/DVD of Photos	\$25.00
CD/DVD of Audio or Video	\$25.00
Fingerprinting	\$10.00 per card

### Parking Tickets:

Parking Ticket (general)	\$15.00 up to 30 days
	\$20.00 after 30 days
Snow Parking Ticket	\$25.00 up to 30 days
	\$30.00 after 30 days
Handicap Parking Tickets	\$200.00 up to 30 days
	\$205.00 after 30 days

# City of Adel Fees for Services

Effective July 19, 2024

## Parks & Recreation Department

*\*Eligible veterans may receive a \$100.00 annual credit on Parks & Recreation programming as a part of the Home Base Iowa program. Registration is still required.*

**\*\*Recreational Programming Fees are published in the Adel Seasonal Activity Guide \*\***

**Adel Family Aquatic Center Rates:** *(Can be changed at any time by the Park Board)*

**\*\*\* Resident rates apply to households located within the ADM School District \*\*\***

<b><u>Daily Pool Rates:</u></b>	
Ages: 0-2	\$2.00
3-54	\$7.00
55+	\$6.00
Family	\$25.00
Family after 5:00 p.m.	\$16.00
<b><u>Season Passes:</u></b>	
Resident Single Pass	\$90.00
Non-Resident Single Pass	\$110.00
Resident Family Pass	\$200.00
Non-Resident Family Pass	\$240.00
Nanny/Granny Pass	\$60.00
Nanny/Granny Non-Resident Pass	\$70.00
<b><u>Swimming Lessons:</u></b>	
Public Lessons	\$50.00
Non-Resident Public Lessons	\$60.00
Private Lessons	\$75.00
Non-Resident Private Lessons	\$85.00
Parent-Tot Class	\$40.00
Parent-Tot Non-Resident Class	\$50.00
<b><u>Pool Rentals/Birthday Party Packages:</u></b>	
Private Pool Rentals	\$120.00/hour
Private Pool Rentals-whole pool	\$270.00/hour
Birthday Party Package	\$110.00

### **Rentals:**

<b><u>Evans Park Shelter, Kinnick-Feller Gazebo, Kinnick-Feller Shelter (South), Island Park Shelter, Raccoon Bank Pavilion (without electricity):</u></b>	
Resident (per 4 hours)	\$30.00 + \$5/extra hour; \$60 Daily Max
Non-Resident (per 4 hours)	\$40.00 + \$5/extra hour; \$70 Daily Max
<b><u>Kinnick-Feller Shelter (North):</u></b>	
Resident (per 4 hours)	\$15.00 + \$3/extra hour; \$30 Daily Max
Non-Resident (per 4 hours)	\$25.00 + \$3/extra hour; \$40 Daily Max
<b><u>Raccoon Bank Pavilion (with electricity):</u></b>	
Resident (per 4 hours)	\$50.00 + \$5/extra hour; \$80 Daily Max

## City of Adel Fees for Services

**Effective July 19, 2024**

Non-Resident (per 4 hours)	\$60.00 + \$5/extra hour; \$90 Daily Max
<b>Adel Ball Field Practice Time:</b>	
Non-Adel Parks & Recreation Teams	\$15.00 per 1.5 hour session per field

### Cemetery Charges:

Standard Space	\$500.00
Mausoleum Space	\$500.00
<b>Opening and Closings:</b>	
Regular Space	\$500.00
Regular Space – (Weekend/OT)	\$600.00
Ashes	\$200.00
Ashes – (Weekend/OT)	\$300.00
Mausoleum	\$50.00
Mausoleum – (Weekend/OT)	\$60.00
<b>Disinterment:</b>	
Infant/Child	\$1,000.00
Adult	\$1,500.00
Ashes in Container	\$1,100.00

### Miscellaneous City Fees:

Mowing or Snow Removal	\$150.00/hr. minimum per lot
Live Traps	\$15.00 + \$80.00 refundable deposit
<u>Impound Fees/Animal At Large</u>	<u>\$50.00</u>
Bulk Water	\$1.00 per 100 gallons
NSF Fees	\$30.00 per check
Appliance Tags	\$15.00*
* TV's 25" and over (2 tags)	\$30.00
* Console & Projection	\$45.00
Fax ( <i>first page</i> )	\$1.00
Additional pages	\$0.50 per page
Copies	\$0.10 per sheet (black and white)
	\$0.75 per sheet (color)
Golf Cart License	\$50.00 per year
Special Event Permit (Public Property)	\$75.00 + \$100 refundable deposit
<i>Additional Charges:</i>	
Street Closure Fee	\$25.00
Late Fee ( <i>App. received 14-30 days prior to event</i> )	\$15.00
Late Fee ( <i>App. received less than 14 days prior to event</i> )	\$30.00
Sound Amplification Permit	\$50.00

**City of Adel Fees for Services**  
Effective July 19, 2024

**Peddlers, Solicitor’s, Transient Merchant, and Mobile Food Unit License Fees**

**Solicitors:**

\$25.00 application fee/person + an annual company fee of \$15.00.

**Peddlers or Transient Merchants:** *(transient merchant must provide evidence of bond)*

\$25.00 application fee per person plus:

One day	\$25.00 per person
One week	\$50.00 per person
Up to 6 months	\$250.00 per person
Up to 1 year	\$500.00 per person

**Mobile Food Units:**

One day	\$25.00
One week	\$50.00
Up to 6 months	\$100.00
Up to 1 year	\$200.00

**Adel Public Library**

**Library Fees:** *(Can be changed at any time by the Library Board)*

Black and white photocopies	\$0.25 per page
Color photocopies	\$0.50 per page
Fax <i>(first page)</i>	\$1.00
Additional pages	\$0.50 per page
Lamination (first foot)	\$2.00
Per Inch	\$0.10 per inch
Meeting room (For Profit Fees): 0-3 hours	\$25.00
Over 3 hours per day	\$50.00



**AGENDA ITEM NO. 6.f**  
**AGENDA SECTION: NEW**  
**BUSINESS**

## **ADEL CITY COUNCIL AGENDA ITEM REPORT**

**MEETING DATE:** July 9, 2024

**TO:** Mayor & City Council

**FROM:** Brittany Sandquist, Deputy City Administrator / Finance Director

**AGENDA HEADING:** Consider Approval of Resolution No. 24-43, Approving City of Adel Employee Handbook for Fiscal Year 2024-2025

### **STAFF/COMMITTEE RECOMMENDATION:**

The following key updates have been made to the 2024 Employee Handbook:

#### **1. Addition of Section on the Pregnant Workers Fairness Act (PWFA):**

\* As recommended by legal counsel, a new section has been added to address the PWFA. On April 15, 2024, the Equal Employment Opportunity Commission (EEOC) issued its final regulation concerning the PWFA, which originally went into effect last year. This act mandates that public and private sector employers with 15 or more employees provide "reasonable accommodations" to employees affected by pregnancy, childbirth, or related medical conditions. The final regulations became effective on June 18, 2024.

#### **2. Update to Section 6.13 - Hiring of Relatives:**

\* Section 6.13 has been revised to permit the hiring of relatives within the same department under specific circumstances and conditions. This change addresses concerns raised by Police Chief Book regarding the potential exclusion of qualified candidates under the previous policy, especially during periods of challenging recruitment.

Both updates have been reviewed and approved by legal counsel.

**City Staff is recommending approval.**

### **ATTACHMENTS:**

[Resolution No. 24-43, Approving the City of Adel Employee Handbook for FY24-25.pdf](#)

2024 City of Adel Employee Handbook - PWFA & Hiring of Relatives Additions (02364322-3x7F7E1).pdf  
Ahlers Alert - Recent Employment Law Updates (PWFA).pdf

**Resolution No. 24-43**

**APPROVING CITY OF ADEL EMPLOYEE HANDBOOK  
FOR FISCAL YEAR 2024-2025**

**WHEREAS**, the City of Adel Employee Handbook was last revised in 2023; and

**WHEREAS**, City staff has completed a review and update of the City of Adel Employee Handbook; and

**WHEREAS**, City staff has proposed an amendment to Section 6.13 Hiring of Relatives to allow for the employment of relatives within the same department under defined circumstances and conditions, thereby eliminating the potential exclusion of qualified candidates during challenging recruitment periods; and

**WHEREAS**, City staff has incorporated Section 6.17 Pregnant Workers Fairness Act to acknowledge the regulations that came into effect mandating that public and private sector employers with 15 or more employees to provide “reasonable accommodations” to pregnant employees concerning their pregnancy, childbirth, or related medical conditions.

**NOW THEREFORE, IT IS HEREBY RESOLVED BY THE CITY COUNCIL OF THE CITY OF ADEL, IOWA** that the 2024 City of Adel Employee Handbook be approved and be effective July 9, 2024.

Passed and approved this 9<sup>th</sup> day of July, 2024.

\_\_\_\_\_  
James F. Peters, Mayor

Attest: \_\_\_\_\_  
Carrie Erickson, City Clerk



# Employee Handbook

Our Mission:

To Provide Exceptional and Fiscally Responsible  
Services that Promote Planned, Sustainable Growth  
and a High Quality of Life

**20234 Version**

## WELCOME TO THE CITY OF ADEL, IOWA

To Employees of Adel:

The most important resource to the City of Adel is its employees. An interesting and challenging experience awaits you as an employee of the City of Adel, Iowa. The City provides diverse services to the citizens of Adel and the surrounding communities. Each of us shares in the responsibility of making Adel a pleasant and safe place to live.

This handbook has been prepared to answer some of the questions you may have concerning the City and its policies. Please read it thoroughly and retain it for future reference. The policies stated in this handbook are subject to change at the discretion of the City Council, as are all other policies, procedures, benefits, or programs of the City. From time to time, you may receive updated information concerning changes in policy. If you have any questions regarding any policies, please ask your supervisor or the City Administrator for assistance.

The contents of this handbook are presented as a matter of information only. This handbook does not, either by itself or in conjunction with any other City documents, policy, procedure, practice, or verbal statement, create an employment contract, express or implied, provide or guarantee employment for any period of time or that employment will be terminated only upon or after certain conditions have been met or have occurred. Bargaining unit agreements govern in the event of a conflict between these policies and the terms of the bargaining agreement.

While it is the hope of the City Council that your employment with the City will be a long and rewarding period for you, it is the policy of the City that all employees are employed "at will," and can be terminated at any time with or without cause or prior notice, unless otherwise required by law. All statements contained in this handbook shall be interpreted to be consistent with this employment-at-will relationship and the requirements of law. No elected official, manager, supervisor, co-employee, or other representative or agent of the City has any authority to modify the "at will" status of any employee unless the modification is expressly made in writing and has been specifically approved in writing by the City Council. Whenever the policies or language of this handbook are in conflict with those of a collective bargaining agreement or any other employment contract, the policies, terms, conditions and language of the collective bargaining agreement or employment contract supersede those of this handbook.

Welcome and congratulations on your employment with the City of Adel. It is our sincere hope that you are successful in your position and that your employment relationship with the City of Adel will be a long and rewarding experience.

James F. Peters,  
**Mayor**

# TABLE OF CONTENTS

<b>WELCOME TO THE CITY OF ADEL, IOWA</b>	<b>1</b>
<b>TABLE OF CONTENTS</b>	<b>2</b>
<b>1. INTRODUCTION</b>	<b>5</b>
1.1 PURPOSE	5
1.2 WHO IS COVERED BY THIS HANDBOOK?	5
1.3 HISTORY OF THE CITY OF ADEL	5
1.4 CHAIN OF COMMAND	6
<b>2. EQUAL EMPLOYMENT OPPORTUNITY (EEO)</b>	<b>8</b>
<b>3. COMPENSATION</b>	<b>9</b>
3.1 PAY PLAN	9
3.2 LICENSE AND CERTIFICATION PAY	9
3.3 WAGE INCREASE POLICY	9
3.4 JOB CLASSIFICATION	9
3.5 PAY PERIODS	11
3.6 LONGEVITY PAY	11
3.7 WAGE GARNISHMENTS	12
<b>4. LEAVE BENEFITS: WITH AND WITHOUT PAY</b>	<b>13</b>
4.1 UNPAID LEAVE	13
4.12 DONATED LEAVE	13
4.2 PAID HOLIDAYS	<del>13</del> 17
4.3 PAID VACATION LEAVE	<del>18</del> 18
4.4 PAID SICK LEAVE	20
4.5 FAMILY MEDICAL LEAVE	<del>22</del> 21
4.6 PREGNANCY LEAVE	<del>25</del> 25
4.7 MILITARY LEAVE	<del>25</del> 25
4.8 BEREAVEMENT LEAVE	<del>25</del> 25
4.9 JURY DUTY	<del>26</del> 26
4.10 VOTING LEAVE	<del>26</del> 26
4.11 SPECIAL LEAVE CONSIDERATIONS	<del>26</del> 26

<b>5. EMPLOYEE BENEFITS</b>	<b><u>2727</u></b>
5.1 INSURANCE	<u>2727</u>
5.2 CONTINUATION OF HEALTH INSURANCE COVERAGE	<u>2828</u>
5.3 FLEXIBLE SPENDING ACCOUNT	<u>2828</u>
5.4 DEFERRED COMPENSATION PLAN	<u>2929</u>
5.5 RETIREMENT	<u>2929</u>
5.6 LENGTH OF SERVICE AWARD	<u>2929</u>
5.7 EMPLOYEE TRAINING	<u>2929</u>
5.8 TUITION REIMBURSEMENT / PROFESSIONAL DEVELOPMENT	<u>2929</u>
5.9 CLOTHING ALLOWANCE	31
<b>6. EMPLOYEE POLICIES</b>	<b><u>32</u></b>
6.1 JOB VACANCY & RECRUITMENT	32
6.2 MEDICAL EXAMINATIONS	32
6.3 PROOF OF EMPLOYABILITY	32
6.4 JOB POSTING	33
6.5 PERSONNEL RECORDS	33
6.6 PROBATIONARY PERIOD	34
6.7 HOURS OF WORK, LUNCH HOURS, & WORK BREAKS	34
6.8 OFFICE ENVIRONMENT	35
6.9 INCLEMENT WEATHER	<u>3636</u>
6.10 RESIDENCY REQUIREMENT	<u>3636</u>
6.11 OUTSIDE EMPLOYMENT	<u>3636</u>
6.12 CITY EMPLOYEES AS PART-TIME FIREFIGHTERS	<u>3636</u>
6.13 HIRING OF RELATIVES	<u>3636</u>
6.14 VEHICLE & EQUIPMENT POLICY	<u>3837</u>
6.15 VOLUNTARY RESIGNATION	<u>3837</u>
6.16 OVERTIME & COMPENSATORY TIME	<u>3938</u>
<u>6.17 PREGNANT WORKERS FAIRNESS ACT</u>	<u>39</u>
<del>7. OCCUPATIONAL SAFETY AND HEALTH</del>	<del>407. OCCUPATIONAL SAFETY AND HEALTH</del>
	<u>40</u>
<del>7.1 SAFETY</del>	<del>407.1 SAFETY</del>
	<u>40</u>
7.2 WORK-RELATED INJURIES	<u>4343</u>
7.3 INDIVIDUALS WITH DISABILITIES	<u>4343</u>
<b>8. EMPLOYEE CONDUCT AND WORK RULES</b>	<b><u>4645</u></b>

**Formatted:** Hyperlink

**Formatted:** Normal, Tab stops: Not at 6.49"

**Formatted:** Font: Bold, Check spelling and grammar, Small caps

8.1 DISCIPLINARY POLICY	<u>4847</u>
8.2 ABSENTEEISM & TARDINESS	<u>504499</u>
8.3 PERSONAL APPEARANCE AND Demeanor	<u>504499</u>
8.4 ELECTRONIC COMMUNICATION	<u>504499</u>
8.5 HARASSMENT	<u>5533</u>
8.6 DRUG FREE WORKPLACE	<u>565555</u>
8.7 SMOKING	<u>585577</u>
8.8 INVESTIGATIONS	<u>585577</u>
<u>9. PERFORMANCE APPRAISAL</u>	<u>605599</u>
<u>10. GRIEVANCE PROCEDURES</u>	<u>6600</u>
<u>11. CAMPAIGN AND ETHICS GUIDELINES</u>	<u>6622</u>
<u>STATEMENT OF RECEIPT</u>	<u>6633</u>

# **1. INTRODUCTION**

## **1.1 PURPOSE**

The contents of this employee handbook are presented as a matter of information only. It is not a contract, expressed or implied. While the City of Adel believes wholeheartedly in the plans, policies, and procedures described here, they are not conditions of employment. The City reserves the right to delete from, add to, and / or revise the employee handbook at any time with or without notice. Although the hope is that your employment relationship with us will be long term, your employment is “at will”, meaning either you or the City of Adel may terminate this relationship at any time, for any reason, with or without notice.

## **1.2 WHO IS COVERED BY THIS HANDBOOK?**

This employee handbook applies to all full-time regular and part-time employees as well as seasonal/temporary employees who work for the City of Adel. The City will mention from time to time when a policy or practice may be the same or slightly different for employees who are working under contract terms, or employees working under a collective bargaining agreement. Whenever the policies, terms, conditions or language of this handbook are in conflict with those of a collective bargaining agreement or any other employment contract, the policies, terms, conditions and language of the collective bargaining agreement or employment contract supersede those of this handbook.

## **1.3 HISTORY OF THE CITY OF ADEL**

The original town was surveyed and plotted by the County Surveyor Martin W. Miller and his deputy Alfred D. Jones. The work was completed May 22nd, 1847. Many additions have been made since. The original plot was situated on the level place near the river on land claimed and owned by John Miller. Adel was the first town established in Dallas County.

The town, when first laid out, was called Penoch at the suggestion of the deputy surveyor, A. D. Jones, and retained that name until sometime in 1849 when it was named Adel in honor of a very pretty child. No record has been found in any of the books for the change, but it was probably done by the legislature.

The first house was built by J. C. Corbell in 1847. Ira Sherman sold the first goods in town, and not long after him, Benjamin Green and George B. Warden each opened stores in 1848.

The first brick building erected in town was a small one-story building occupied by G. W. Campbell as a tailor shop.

From these humble beginnings sprung a bustling city with more than 46,000 residents. Adel, with its historic courthouse standing among businesses which line all four sides of its square, has experienced steady growth over the years while maintaining its small-town feel.

As the county seat, Adel's courthouse was, and still is, the centerpiece. The building is a superb example of French chateau architecture and has majestically presided over Adel's central business district since 1902.

Adel is an example of how a city can maintain its unique character while remaining true to its past. The City has a variety of civic groups and organizations, a strong school system, and an Adel Partners / Chamber of Commerce program that help maintain and promote a strong business environment.

A big drawing point each year is the annual Sweet Corn Festival, which brings thousands of people into the community to enjoy free sweet corn and the many events which accompany it.

Adel is one of the few remaining communities with brick streets, and the small village has grown into one of Dallas County's golden locales. Its growth continues, and its inhabitant's view toward the future is reflected in its welcoming sign which reads: "Adel, Growing with Pride."

#### **1.4 CHAIN OF COMMAND**

On the next page you will find the City's chain of command.

Unless otherwise stated in this handbook, this chain of command is used primarily for emergency management and other advisory situations.

**CITY OF ADEL CHAIN OF COMMAND**

**CITY DEPARTMENTS**

1. Employee
2. Supervisor
3. City Administrator
4. Mayor
5. Personnel Committee
6. City Council

**POLICE DEPARTMENT**

1. Patrol officer
2. Sergeant
3. Lieutenant
4. Police Chief
5. Mayor
6. Public Safety Committee
7. City Council

**FIRE DEPARTMENT**

1. Firefighter
2. Fire Chief
3. Mayor
4. Public Safety Committee
5. City Council

## **2. EQUAL EMPLOYMENT OPPORTUNITY (EEO)**

The City of Adel is an equal opportunity employer and is committed to fair and equal treatment of all employees without regard to race, color, age, religion, sex (including pregnancy), sexual orientation, gender identity, genetic disposition, ancestry, national origin, status as a United States Military Veteran or special disabled veteran in accordance with applicable federal laws, disability that does not interfere with job performance with reasonable accommodation, or any other legally protected status.

The Equal Employment Opportunity Officer for this organization shall be the duly elected Mayor. The Mayor has the power to delegate such duties and may, from time to time, do so. The EEO Officer shall be responsible for interpreting, initiating, and justifying the City's activities in this program as they relate to City policies, including contract compliance. Inquiries or grievances may be directed to the City's EEO Officer, the U.S. Equal Employment Opportunities Commission, Milwaukee Area Office, Reuss Federal Plaza, 310 West Wisconsin Avenue, Suite 500, Milwaukee, Wisconsin 53203-2292, or the Iowa Civil Rights Commission, 400 E. 14th Street, Des Moines, Iowa 50319.

The City is committed to administering all personnel actions in compliance with federal and state regulations. The City refrains from using policies that discriminate in such matters as employment, promotion, demotion, transfer, compensation, benefits, training, and education. The City's policies also prohibit harassment of any kind. If any employee feels discriminated against or harassed, the employee should timely bring this matter to the attention of either his/her immediate supervisor or to the Mayor as provided for in this handbook. All complaints will be investigated and resolved promptly. The confidence of the employees involved will be maintained to the extent possible.

## **3. COMPENSATION**

### **3.1 PAY PLAN**

The City seeks to balance the need to be prudent with public funds and the compensation needs of its employees. The City competes for a talented, dedicated workforce in the same labor market as private sector employers. Accordingly, the City frequently assesses the labor market in order to determine the competitiveness of your pay plan. We offer a competitive total compensation package and a work environment where you can feel good about your contribution to improving the community where you work.

### **3.2 LICENSE AND CERTIFICATION PAY**

The City will provide additional compensation to an employee's base rate of pay for obtaining and maintaining the following licenses and certifications when they are related to an employee's job duties, but not required of the position:

Water Treatment / Operations Certificate	50 cents per level per hour
Water Distribution Certificate	50 cents per level per hour
Wastewater Treatment / Operations Certificate	50 cents per level per hour
Wastewater Collection Certificate	50 cents per level per hour
Certified Pool Operator License	20 cents per hour
Pesticide Applicator License	20 cents per hour

An employee will receive the additional compensation as set forth above beginning the pay period after the employee has obtained the license or certification.

### **3.3 WAGE INCREASE POLICY**

Wage increases will be set by the budget committee in conjunction with the personnel committee. The wage and wage increase processes are not subject to the Complaint Resolution Procedure in section 10.

### **3.4 JOB CLASSIFICATION**

The job classification plan shall consist of the various classification titles as approved by the City Council. The plan shall be administered by the City Administrator to ensure that the job class specifications are accurate and current.

For purposes of salary administration and eligibility for overtime payments and employee benefits, the City classifies its employees as follows:

1. **Full-time regular employees:** Employees hired to work the City's normal 40-hour workweek on a year-round regular basis. Such employees may be "exempt" or "nonexempt" as governed by the Fair Labor Standards Act ("FLSA") and defined below.
2. **Part-time regular employees:** A part-time regular employee is an employee who is regularly scheduled to work year-round with a minimum of 20 hours, but less than 40 hours worked per week. This definition does not include seasonal workers, temporary workers, or part-time paid members of the fire department.
3. **Part-time limited employees:** A part-time limited employee is an employee who is scheduled to work year-round with less than 20 hours worked per week. This definition does not include seasonal workers, temporary workers, or part-time paid members of the fire department.
4. **Part-time seasonal employee:** Employees who are hired to work on a seasonal basis not exceeding seven months in each calendar year. [Part-time](#) seasonal employees may be scheduled to work up to 40 hours per week. However, part-time seasonal employees are not eligible for benefits.
5. **Part-time recreational employee:** Employees who are hired to work on a seasonal basis not exceeding six months in each calendar year at a City-operated recreational facility. Part-time recreational employees are not eligible for benefits.
6. **Volunteer:** An individual who agrees to perform services for the City and does not receive compensation, therefore. Certain volunteers, however, depending on circumstances, may be entitled to reimbursement of expenses, a nominal stipend to assist in the performance of volunteer services, and reasonable limited benefits (such as coverage by workers' compensation insurance).
7. **Nonexempt employees:** Employees who are required by the FLSA to be paid overtime at the rate of time and [one-half](#) (i.e., one-and-one-half times) their regular rate of pay for all hours worked beyond forty hours in a workweek, in accordance with applicable state and federal wage and hour laws.
8. **Exempt employees:** Employees who are not required to be paid overtime, in accordance with the FLSA, for work performed beyond forty hours in a workweek. Employees are informed of their initial employment classification as exempt or nonexempt when hired. If you change positions during your employment as a result of a promotion, transfer, or otherwise, you will be informed by the City Administrator of any change in your FLSA-exemption status.

### 3.5 PAY PERIODS

All City employees hired on or after July 1, 2005, are required, as a condition of employment, to participate in direct deposit of the employee's wages in a financial institution of the employee's choice; employees hired before then may be paid by either check or direct deposit. Wage payments are normally paid on a semimonthly basis, usually after 10:30 a.m. on the fifth and twentieth days of each month. If a scheduled payday falls on a Saturday, Sunday, or City-observed holiday, you will be paid on the day preceding the weekend or holiday. [Time sheets](#) [Timesheets](#) are to be turned in to the payroll clerk on the morning of the first and sixteenth of each month or the first working day thereafter.

All required deductions from your gross wages, such as for federal, state, and local taxes, and matching Social Security payments, will be computed by a government tax guide table. Employees are also subject to required withholdings for participation in the Iowa Public Employees Retirement System (IPERS). All authorized deductions will be withheld automatically from your paychecks.

Please review your paycheck for potential errors. If you believe there is a mistake, you should immediately report such to your supervisor who will, if necessary, assist you in taking the steps to correct the error.

In the event your paycheck is lost or stolen, please notify your supervisor immediately. Your supervisor will, in turn, notify the City's Finance Director who will attempt to put a stop-payment notice on your check. Unfortunately, however, the City is unable to take responsibility for lost or stolen paychecks, and if it is unable to stop payment on your check, you alone will be responsible for such loss.

The City reserves the right to correct any errors in payroll and recover any money paid in error.

### 3.6 LONGEVITY PAY

For full-time regular exempt employees, the City provides an annual longevity award payment following your employment anniversary date every year.

Longevity payments will be issued as a separate deposit or paycheck during the pay period immediately following your anniversary date. The longevity payment amount is based on your full years of service with the City. The payment amount is currently \$104.00 multiplied by your full years of completed service ( $\$104.00 \times \text{___ full years}$ ).

Pro-rated longevity payments are only provided upon an eligible employee's IPERS retirement.

For full-time regular non-exempt employees, the City includes a longevity award rate on top of your hourly wage. This amount is \$0.05 multiplied by your full years of service and is factored

in overtime calculations. For example, if you have worked here one full year, your hourly wage would include an additional \$0.05. If you have worked here three full years, your hourly wage would include an additional \$0.15.

### **3.7 WAGE GARNISHMENTS**

We expect our employees to meet their financial obligations. Wage garnishments against an employee's salary cause extra work, time, and expense for the City. Accordingly, the City expects you to work towards preventing wage garnishments for failing to satisfy your financial obligations. But, when it is necessary, the City will work with any local, county, state, or federal agencies regarding employee wage garnishments as provided by law.

## **4. LEAVE BENEFITS: WITH AND WITHOUT PAY**

### **4.1 UNPAID LEAVE**

Full-time regular and part-time regular employees may ask their department head for an absence without pay after six months of service with the City of Adel. The request shall be submitted in writing indicating the reason and length of time of absence. While an employee is on approved unpaid leave, leave benefits will not continue to accrue. During the first ninety (90) days of approved unpaid leave, the Employer will continue to make its contribution to employee insurance plans so long as the employee continues, during that period, to pay the employee's share, if any. Thereafter, if the employee wishes to continue insurance coverage, and if doing so is allowed by the carrier, the employee will be responsible for both the Employer's and the employee's share of premiums. Premiums must be paid directly to the City Finance Director. Arrangements for the time of payment must be made with the City Finance Director prior to the employee going on unpaid leave. An employee's failure to make timely payment of insurance premiums under this Section may result in his or her loss of insurance coverage with the City.

Exceptions to this policy must be approved by the City Administrator or designee.

### **4.12 DONATED LEAVE**

#### **POLICY STATEMENT:**

The City of Adel recognizes that an employee or immediate family member may suffer from a catastrophic illness or injury resulting in circumstances where the employee lacks sufficient paid leave time to care for themselves or a family member. The City will allow employees an opportunity to donate accumulated leave to an employee who has exhausted all forms of paid leave for which the employee was eligible. This policy is strictly voluntary and for the sole purpose of assisting employees who have a personal or family catastrophic illness or injury. An employee may not directly or indirectly intimidate, threaten, or coerce any other employee or interfere with any right that employee may have with respect to donating, receiving, or using available leave. Such acts of coercion will be the basis for taking disciplinary actions. The City Administrator or designee has the authority to grant exceptions to this policy by modifying or waiving any provision pertaining to eligibility or procedure. This will only be given consideration upon a joint recommendation by the appropriate department director and Finance Director.

#### **APPLICABILITY:**

All regular full-time or regular part-time employees who have been employed for at least twelve (12) months are eligible to receive or donate leave as described below. If an alternative procedure has been negotiated in an applicable labor contract that contract provision shall supersede this policy.

#### **DEFINITIONS:**

*Catastrophic illness or injury* is a physical or mental illness, as certified by a licensed physician, which will result in the inability of the employee to report to work for more than 30 work days (6

weeks) on a consecutive or intermittent basis during a 12 month period. The catastrophic illness or injury may apply to either the employee or immediate family member. Chronic conditions associated with the debilitating illness or injury that result in intermittent absences from work may be considered catastrophic (i.e., cancer, residual effects of a stroke, etc.)

**Immediate family members** for purposes of this policy are defined as the requesting employee's spouse, child, or parent as defined by FMLA regulations.

**Donated leave** is the permanent transfer of accrued leave to a recipient employee's donated leave bank. Donated leave must come from vacation, compensatory time, or floating holidays. Donation of sick leave will not be allowed.

**Recipient employee** is an employee whose request for donated leave has been approved by the Finance Director and City Administrator. The employee must have used all forms of paid leave including available sick leave, vacation, floating holidays, and compensatory time for which they are eligible.

**PROCEDURES:**

A. Requesting Donated Leave

1. An employee requesting donated leave is required to complete a Request to Receive Donated Leave Form and submit it to the employee's department director. The request should explain the nature and extent of the catastrophic illness or injury. This form will then be forwarded to administration to be approved by the Finance Director and the City Administrator. False statements or other misrepresentations made in connection with an employee's request may be the cause for: disqualification from the program; disciplinary action, up to and including termination; and liability for the amount of leave dishonestly gained.
2. The City will review the employee's form and notify the employee of the approval or disapproval of the request within 10 working days after receipt.
3. If the request is approved, a notice will be sent by administration to all employees stating that a fellow employee is in need of assistance and all employees will be given the chance to make a donation on the Request to Donate Leave Form provided by administration. The employees will be able to donate their leave time for a period of ten (10) working days. To protect the privacy of the requesting employee's medical condition, only the employee's name and a statement that the employee has been approved to receive donated time due to a catastrophic illness for themselves or an immediate family member will be released.

4. An employee may receive up to 480 hours of donated leave within a rolling twelve-month period. Donated leave may be used up to the point that the employee qualifies for short term disability.
5. Recipient employee whose anniversary date allows him/her to accrue additional vacation time, or who is accruing PTO per pay period, will be allowed to maintain a balance of no more than one week while receiving donated leave.
6. The recipient employee will earn service credit toward retirement and seniority while using donated leave in the same manner as other paid leave time.
7. Donated leave for a catastrophic illness or injury cannot be used retroactively for a previous unpaid absence.
8. Donated leave may not be used to extend a date of retirement.
9. Donated leave time is subject to the recipient employee's normal payroll deductions and is subject to all taxes as required by law. When FMLA leave and donated leave are used concurrently, the City is obligated to pay its share of health and dental insurance as long as the employee continues his/her share of the premium.
10. Employees may choose to continue or terminate their optional deductions while using donated leave hours. Mandatory deductions are taken from gross pay first, then optional deductions as funds are available and authorized by the employee.

B. Making a Leave Donation

1. Donating leave to another employee for a catastrophic illness or injury is on a strictly voluntary basis. No employee shall be coerced, threatened, intimidated, or financially induced into donating paid leave time to any employee.
2. The donor will remain anonymous unless the donor chooses otherwise.
3. Persons involved in the administration of this program are responsible for guarding the privacy of the participants.
4. Each donation must be directed to a specific eligible employee for whom a request has been made.
5. The donor employee must complete a Request to Donate Leave Form and submit it to the Finance Director.

### C. Donated Leave Bank

1. Donated leave may be given in one (1) hour increments up to a maximum of twenty-four (24) hours or no more than 50% of an employee's current balance per request. Donated leave may come from vacation, compensatory time, or floating holiday accruals.
2. Donated time will be deducted from the donating employee's accrued leave bank(s) during the next payroll process. Once the leave is transferred it is irrevocable.
3. Donations are not tax deductible for the donating employee.
4. All donated time will be converted into dollars based on the donating employee's current hourly pay rate. These dollars will be pooled together to create a Donated Leave Bank to be used by the eligible employee.

*Example: Employee Jane Smith donates 16 hours of vacation, at the rate of \$20 an hour.  $(16 \times \$20) = \$320$  donated; total pool equals \$12,000; eligible employee John Smith, has a pay rate of \$15 an hour and he needs 80 hours for this pay cycle.  $(\$12,000 - (\$15 \times 80)) = (\$12,000 - \$1,200) = \$10,800$  pooled funds remaining.*

5. Donated leave will be transferred from the Donated Leave Bank to the recipient as needed to complete the standard work hours for a pay period.
6. If the eligible employee is no longer in need of donated leave, due to returning to work, retirement, termination of employment, or being eligible for other coverage, the unused pool of funds will be calculated and returned to those employees who had donated time.
7. Returned hours will be calculated based on the percentage of dollars contributed by the donating employee to the total donated. That percentage will be applied to the unused total, then allocated back to the donating employee. These funds will then be converted back to the donated time's type (vacation, compensatory time, or floating holiday) and donating hourly rate and applied back to the donating employee's leave accrual rounded to the nearest quarter hour.

*Example: Jane Smith donated 16 hours of vacation for \$320 or 2.7% of the total pool of \$12,000  $(320/\$12,000)$ . The unused pool amount left is \$2,400. Jane Smith's percentage of the unused pool is  $(\$2,400 \times 2.7\%) = \$64.80$ . Jane's donating rate of pay was \$20 an hour and her returned vacation would be 3.25 hours  $(\$64.80/\$20)$ .*

## 4.2 PAID HOLIDAYS

The City provides paid time off to all full-time regular and part-time regular employees on the following holidays:

1. New Year's Day, January 1
2. Presidents' Day, the third Monday in February
3. Memorial Day, the last Monday in May
4. Independence Day, July 4
5. Labor Day, the first Monday in September
6. Veteran's Day, November 11
7. Thanksgiving Day, the fourth Thursday in November
8. Friday after Thanksgiving Day
9. Christmas Eve, December 24
10. Christmas Day, December 25
11. Three floating holidays – three floating holidays will be added in January of each year or upon the date of a new employee's hire. Part-time regular employees are provided floating holidays on a prorated basis based on regularly scheduled hours.

If a holiday falls on a part-time regular employee's regularly scheduled workday, they shall be paid pro rata for these holidays based on the number of hours they would normally have been scheduled to work, if any, had the day not been a holiday.

Full-time regular and part-time regular employees shall be paid for each of the holidays set forth in this section occurring during the period in which they are in paid status. An employee required to work on a recognized paid holiday shall be granted compensatory time off or cash, as provided for in section 6.16, at the rate of time and one-half (1 1/2) for all hours worked. Holiday pay will be at the employee's normal pay for the day on which he/she would have been scheduled to work.

To be eligible for holiday pay, an employee must have worked the last full scheduled workday immediately before and the first full scheduled workday immediately after each holiday, unless prior approval has been given for the employee to be on paid leave. An employee on layoff or unpaid leave is not eligible for holiday pay.

If you are on a paid leave of absence, and the holiday occurs during your leave, the holiday will not be counted as part of that leave of absence.

Paid holidays falling on a Saturday are normally observed on the preceding Friday. Holidays falling on a Sunday are normally observed on the following Monday. When Christmas falls on a Monday or a Thursday, the following workday shall be observed as the "Christmas Eve" holiday. When Christmas falls on Tuesday, Wednesday, or Friday, the preceding workday shall be observed as the Christmas Eve holiday. When Christmas falls on Saturday or Sunday, the preceding Friday and the following Monday will be observed as holidays.

Commented [CE1]: What?  
 Commented [BS2R1]: Discussed, leaving as is.

The police department will observe the actual dates of the holidays as listed above in Section 4.2 (1) - (10).

**4.3 PAID VACATION LEAVE**

Because we recognize the importance of vacation time in providing the opportunity for rest, recreation, and personal activities, the City provides annual vacation leave to its full-time regular and part-time regular employees. The amount of vacation leave which you accrue depends on your length of service with the City as of your anniversary date. Full-time regular employees accrue vacation leave, beginning with an employee's first day of employment, as follows. Part-time regular employees accrue vacation leave on a prorated basis based on regularly scheduled hours.

Years of Service	Hours Per Month	Equivalent Hours	Annual Days
0 to 5	6 2/3	80	10
5+ to 10	10	120	15
10+ to 15	11 2/3	140	17.5
15+ to 20	13 1/3	160	20
20+ to 25	15	180	22.5
25+	16 2/3	200	25

You will be eligible to take vacation once it accrues on your payroll record or as approved by the City Administrator or designee, or Police Chief for the Police Department.

*Vacation Carryover*

Vacation may be taken as time accrues at any point during the year. At the pay period following your anniversary date, any unused vacation hours above your allowable carryover hours will be eliminated according to the schedule below:

Years of Service	Carryover Hours Allowed Beyond Anniversary Date
0 to 5	80
5+ to 10	120
10+ to 15	140
15+ to 20	160
20+ to 25	180
25+	200

*Pay in Lieu of Vacation*

Employees are required to take their earned vacation. No payments will be made in lieu of taking vacation, except for an employee's accrued unused vacation leave balance at the time of his or her termination of employment with the City. Employees terminating employment with the City for any reason after twelve months of service with the City are entitled to payment for his or her accrued unused vacation leave balance, up to the employee's maximum allowed annual accrual. An employee who fails to provide the appropriate advance notice of resignation pursuant to Section 6.15 of the Handbook will forfeit his or her ability to receive payment for any accrued, unused vacation leave.

*Holiday within Vacation Period*

In the event that a holiday observed by the City falls within an employee's scheduled vacation period, and the employee is regularly entitled to the holiday, the holiday will not be counted against the employee's vacation leave balance.

*Vacation Scheduling*

Vacation leaves and schedules must be approved by the employee's supervisor at least two (2) weeks prior to the requested time off when possible. Vacations will be granted within a department on a first come, first served basis after considering the staff coverage needs for each department. Vacation leave shall not be granted for a period longer than two (2) consecutive weeks, except for Police Department employees on a 6 / 3 work schedule. Police Department employees on a 6/3 work schedule shall not be granted vacation for a period longer than twelve (12) days.

#### 4.4 PAID SICK LEAVE

The City recognizes that inability to work because of illness or injury may cause economic hardship. The City also recognizes that employees may require time off to secure necessary treatment for illnesses, injuries, and/or disabilities. For these reasons, the City provides paid sick leave to its full-time regular and part-time regular employees. Paid sick leave shall accrue at the rate of one (1) workday (8 hours) for each month of service up to a maximum of 120 workdays (960 hours). Part-time employees accrue sick leave on a prorated basis based on regularly scheduled hours.

You shall notify your immediate supervisor at least thirty (30) minutes prior to your regular scheduled reporting time if you are going to be absent. Your supervisor may require a doctor's confirmation of your illness, injury, and/or claim you were under the doctor's care.

No payments are made for accrued unused sick days at the end of any calendar year or in the event of termination.

Use of paid sick leave shall be granted and administered under the following circumstances:

1. Personal illness or to care for an ill or injured family member. Family member in this instance is defined as a spouse, a child, or a parent.
2. Doctor and dental appointments that cannot be scheduled during non-working hours. When possible, employees shall provide two weeks' notice to their immediate supervisor for doctor and dental appointments that are scheduled during working hours. Every effort should be made to minimize disruption to the workday.
3. Sick leave may not be used for cosmetic or elective surgeries.
4. Sick leave shall be chargeable only when used on regularly scheduled workdays or work periods.

Abuse of sick leave or falsification of reasons for requesting sick leave is prohibited and will subject an employee to discipline, up to and including termination of employment. In addition, if the City determines that an employee's use of sick leave was not justifiable under this policy, the sick leave used by the employee may be charged to vacation or be treated as leave without pay.

An employee who calls in sick without any sick leave available and does not report for duty as scheduled will be considered Absent Without Pay (AWOP) and may be subject to discipline in accordance with the City's policies.

Before you will be permitted to return from sick leave, you may be required to present the City with a note from your physician indicating that you are capable of returning to work and

performing the essential functions of your position with or without reasonable accommodation. Where required, the City will consider making reasonable accommodation for any disability you may have in accordance with applicable laws.

#### **4.5 FAMILY MEDICAL LEAVE**

In accordance with the Family and Medical Leave Act, the City will grant unpaid family and medical (FMLA) leave to eligible employees for up to twelve (12) weeks per twelve (12) month period for any one or more of the following reasons:

- The birth of a child and to care for such child within one year of birth or the placement of a child with the employee for adoption or foster care within one year of placement; or
- To care for an immediate family member (spouse, child, or parent including stepchildren and stepparents) of the employee if such immediate family member has a serious health condition; or
- The employee's own serious health condition that makes the employee unable to perform the functions of his/her position.

1. **Eligibility.**

To be eligible for FMLA leave, an employee must have at least twelve months of service and have worked at least 1,250 hours over the previous twelve (12) month period. Employees are required to meet notification and documentation requirements as outlined further in this policy. Failure to meet these requirements may result in the denial or revocation of FMLA leave.

2. **Definitions.**

- a. "Twelve Month Period" means a rolling twelve month period measured backward from the date an employee uses FMLA leave (each time an employee takes FMLA leave, the remaining leave is the balance of the 12 weeks not used during the immediately preceding 12 months).
- b. "Spouse" does not include unmarried domestic partners. If both spouses work for the City, their total leave in any twelve-month period may be limited to an aggregate of twelve weeks if the leave is taken for either the birth or placement of a child for adoption or foster care or for care of an employee's sick parent.
- c. "Child" means a child either under eighteen (18) years of age, or eighteen (18) years of age or older who is incapable of self-care because of a mental or physical disability.

An employee's "child" is one for whom the employee has day-to-day responsibility for care and includes a biological, adopted, foster or stepchild.

d. "Serious Health Condition" means an illness, injury, impairment, or a physical or mental condition that involves:

- Inpatient care; or
- Any period of incapacity requiring absence from work, school, or regular daily activities for at least three (3) consecutive days AND that involves continuing treatment by a health care provider; or
- Continuing treatment by or under the supervision of a health care provider for a chronic or long-term health condition that is incurable or which, if left untreated, would likely result in a period of incapacity of more than three calendar days; or
- Prenatal care by a health care provider or incapacity due to pregnancy

### **3. Intermittent or Reduced Schedule Leave**

An employee may take FMLA leave intermittently (a few days or a few hours at a time) or on a reduced schedule basis when medically necessary to care for an immediate family member with a serious health condition or because of a serious health condition of the employee. "Medically necessary" means that there must be a medical need for the leave and the leave can best be accomplished through intermittent leaves or a reduced schedule. The employee may be required to transfer temporarily to a position with equivalent pay and benefits that better accommodates recurring periods of leave or a reduced schedule. The employee must make a reasonable effort to schedule treatment(s) so as not to unduly disrupt the City's operations. If an employee requests reduced or intermittent leave, once the intermittent or reduced leave has been completed, the employee must be transferred back to the same position that the employee held prior to taking the FMLA leave or to an equivalent position. An employee may take leave intermittently or on a reduced schedule for birth or placement for adoption or foster care of a child only with the City Administrator's consent.

### **4. Notice Requirement**

An employee is required to give thirty (30) days' notice in the event of a foreseeable leave. A "Request for Family/Medical Leave" form should be obtained from the City Finance Director. In unexpected or unforeseeable situations, an employee should provide as much notice as possible.

### **5. Medical Certification**

The employee must give notice of the leave, and the City then requires a certificate be completed by a doctor or practitioner no later than fifteen (15) calendar days after the notice of the leave is given. A "Physician Certification Form" is available from the City Finance Director. The City may also require a second or third opinion at the City's expense. Periodic reports on the

employee's status, intent to return to work, and a fitness-for-duty report to return to work will be required.

**6. Effect on Benefits**

Taking FMLA leave will not result in the loss of any employee benefit accrued prior to the date on which the leave began. Benefits will continue to accrue during paid leave but will not accrue during unpaid FMLA leave.

**7. Continuation of Health Insurance on FMLA Leave**

An employee on FMLA leave may remain a participant in the City's health insurance plan throughout the duration of the leave, as if actively employed. S/he will be required to pay the same cost of coverage as if actively at work. Employee contributions will be required either through payroll deduction or by direct payment to the City. The employee will be informed of the amount and method of payment at the beginning of the leave. Loss of insurance coverage may result if the premium amount is paid more than thirty (30) days late. If the employee misses a premium payment and the City pays the employee's contribution, the employee will be required to reimburse the City for the delinquent payment upon return from the leave. In some cases, if an employee does not return to work following an FMLA leave, the City may require reimbursement for the insurance premiums paid during the leave.

**8. Return to Work**

An employee returning from leave taken under this provision is entitled to return to the position held when the leave began if that position is vacant. If the position is not vacant, the employee must be returned to an equivalent position with equivalent benefits, pay and other conditions.

**9. FMLA for Military Families**

The FMLA includes coverage for eligible employees to care for qualifying service members. Eligible employees may take 26 workweeks of leave during a single 12-month period to care for a covered service member with a serious injury or illness who is the spouse, son, daughter, parent, or next of kin to the employee (Military Caregiver Leave). The second type of leave available to certain military families is known as Exigency Leave and entitles eligible employees to up to 12 weeks of leave because of "any qualifying exigency" arising out of the fact that a qualifying family member is on active duty in a foreign country or has been notified of an impending call to active duty status in a foreign country. For purposes of this policy, adult children are qualifying family members.

Unless otherwise stated in this provision, the FMLA policy described above applies.

Paid leave must be extinguished first before unpaid military family FMLA leave is taken. The paid leave and military FMLA leave shall run concurrently. Both types of military family FMLA leave are subject to certification or other verification requirements. Where an employee fails to timely comply with any such requirements, or where this process establishes time off and absences from work are not covered by FMLA, the FMLA leave may be delayed or denied and any absences and time off may be considered unexcused absences subjecting the employee to disciplinary action, up to and including termination of employment.

a. Injured Service Member (Military Caregiver) Leave

An eligible employee who is the spouse, son, daughter, parent, or next of kin of a covered service member who is recovering from a serious illness or injury which was sustained or aggravated in the line of duty on active duty is entitled to up to twenty-six (26) weeks of leave in a single 12-month period to care for the service member. A covered service member is a current member of the Armed Forces, including a member of the National Guard or Reserves, who has a serious injury or illness which was incurred or aggravated in the line of duty on active duty; or a veteran who has a serious injury or illness which was incurred or aggravated in the line of duty on active duty and who was a member of the Armed Forces, including the National Guard or Reserves, at any time within five (5) years of receiving treatment that triggers the need for military caregiver leave. This military caregiver leave is available during “a single 12-month period” during which an eligible employee is entitled to a combined total of twenty-six (26) weeks for all types of FMLA qualifying reasons. The other types of FMLA leave remain subject to the 12-week limit per year.

For Military Caregiver Leave, the employee and employee’s spouse may be limited to a combined total of twenty-six (26) weeks of leave in a 12-month period, including other types of FMLA leave listed above. If a medical certification to support the FMLA Military Caregiver Leave is obtained from a healthcare provider affiliated with the military, such certification will not be subject to second and third opinions.

b. Active Duty Family Leave (Exigency Leave)

Eligible employees are entitled to up to twelve (12) weeks of leave because of “any qualifying exigency” arising out of the fact that the spouse, son, daughter, or parent of the employee is a member of any branch of the Armed Forces, including the National Guard or Reserves, and is on active duty in a foreign country or has been notified of an impending call to active duty status in a foreign country. This leave is subject to the same aggregate twelve (12) weeks of FMLA leave per year as the traditional forms of FMLA leave.

#### **4.6 PREGNANCY LEAVE**

Employees who are disabled from performing their duties because of medical reasons associated with pregnancy or post-delivery problems related to pregnancy, shall be allowed to use their paid leave benefits provided herein on the same basis as employees whose disability is related to other illness or injury. The FMLA policy outlined in this handbook applies. In addition, pursuant to Iowa Code section 216.6(2)(e), any employee who is not eligible for FMLA leave is entitled up to eight weeks of unpaid leave due to the employee's pregnancy, childbirth, or related medical conditions.

#### **4.7 MILITARY LEAVE**

A military leave of absence will be granted for employees subject to USERRA and Iowa Code section 29A.28 (1) (a). Up to the first thirty (30) days of military leave are granted without loss of pay.

While on extended leave, the employee's accumulated leave and placement on the salary schedule shall be frozen. While no additional benefits will be provided by the City during the leave period, the employee may purchase such benefits. At the conclusion of the extended leave of absence, the salary of the employee shall be the salary stated on the salary schedule for the step and class for which that employee was appointed at the time of the commencement of the leave.

#### **4.8 BEREAVEMENT LEAVE**

If you are a full-time regular or part-time regular employee and a death occurs in your family, you will be compensated for time lost from your regular work schedule in accordance with the following guidelines:

1. The City may grant up to five days off from work with pay in the event of the death of your spouse, child, parent, sibling, grandparent, grandchild, father-in-law, mother-in-law, son-in-law, daughter-in-law, brother-in-law, or sister-in-law. The City may grant up to one day off from work with pay in the event of the death of your aunt or uncle. The City may grant up to a half day off if you serve as a pall bearer for an individual not otherwise listed above.
2. Requests for bereavement leave should be made in advance to either your immediate supervisor or the City Administrator, specifying the approximate length of leave desired. The length of time requested should reflect such factors as the location of the funeral and the employee's involvement in making the funeral arrangements.
3. Exceptions to this policy may be granted due to special circumstances but require the approval of the City Administrator or designee.

#### **4.9 JURY DUTY**

If you are a full-time regular or part-time regular employee who is summoned to jury duty, the City continues your salary during your active period of jury duty for up to a maximum of fifteen working days per calendar year. You must turn over to the City the allowance you receive from the court for such service (except reimbursement for meals and mileage). If you are not a full-time regular or part-time regular employee, you will be granted time off without pay while serving jury duty. All employees are allowed unpaid time off if subpoenaed to appear in court or in a deposition as a witness.

To qualify for jury or witness duty leave, you must submit to your supervisor a copy of the summons to serve as soon as it is received. In addition, proof of service must be submitted to your supervisor when your period of jury or witness duty is completed.

The City will make no attempt to have your service on a jury postponed except when the job function is exceptionally vital to the City. If released from jury duty when more than two (2) hours of the employee's regularly scheduled workday remains, the employee will be required to report to work. An employee who is scheduled to work a night shift the night before reporting to jury duty may be excused from their scheduled shift upon approval by their supervisor.

#### **4.10 VOTING LEAVE**

All City employees are entitled to vote in an election. If an employee does not have three consecutive hours of non-working time in the period between the opening and closing of the polls, he or she is entitled to limited paid time off to go vote. Notice must be given, and approval granted by the employee's supervisor, prior to taking leave.

#### **4.11 SPECIAL LEAVE CONSIDERATIONS**

Other than as stated above, no credit for previous years of service will be given as it pertains to the provision/accrual of these leave benefits. Credit will be given for time served should the employee's status change from part-time to full-time.

## 5. EMPLOYEE BENEFITS

The City has established a variety of employee benefits programs designed to assist eligible employees and their dependents in meeting the financial burdens that can result from illness, disability, and death, and to help you plan for retirement, handle job-related or personal problems, and enhance your job-related skills.

This section of the handbook highlights some features of our benefits program. Our group health, dental, disability, and life insurance programs are described more fully in summary plan description booklets, with which you are provided once you are eligible to participate in these programs. Complete descriptions of our group insurance programs are also in the City's master insurance contracts with insurance carriers, which are maintained by the City Clerk / City Finance Director.

The City reserves the right to amend or terminate any of these programs or to require or increase employee premium contributions toward any benefits with or without advance notice at its discretion. This reserved right may be exercised in the absence of financial necessity. Whenever an amendment is made to any of the City's benefits programs, the respective plan administrator will draft and submit the amendment to the City's personnel committee for review and approval. The respective plan administrator will notify plan participants of all approved amendments or plan terminations.

### 5.1 INSURANCE

The City makes group insurance available for full-time regular employees and their families. The program is actively monitored to provide a cost-effective foundation upon which you can build the security and well-being required for you and your family. The following is a brief outline of the coverage made available to City employees:

1. Health

2. Dental

~~2-3.~~ Vision

~~3-4.~~ Life Insurance

~~4-5.~~ Short & Long-Term Disability

~~5-6.~~ Accident & Critical Illness

Formatted: Indent: Left: 0.5", No bullets or numbering

## 5.2 CONTINUATION OF HEALTH INSURANCE COVERAGE

If you resign or your employment is otherwise terminated, or if your work hours are reduced, and consequently you or your dependents are no longer eligible to participate in the group health insurance plan offered by the City, you and your eligible dependents may have the right to continue to participate for up to 18 months at your (or your dependents') expense. The 18-month continuation coverage period provided in the event of your termination or reduction in working hours may be extended to 36 months for your spouse and dependent children, if, within that 18-month period, you die or become divorced or legally separated, or if a child ceases to have dependent status. In addition, if you enroll for Medicare during the 18-month period, your spouse and dependent children may be entitled to extend their continuation period to 36 months, starting on the date that you become eligible for Medicare.

If you are determined to be disabled under the Social Security Act at the time of your termination or reduction in hours, you may be entitled to continuation coverage for up to 29 months.

Your eligible dependents may extend coverage, at their expense, for up to 36 months in our group health insurance plans in the event of your death, divorce, legal separation, or enrollment for Medicare benefits, or when a child ceases to be eligible for coverage as a dependent under the terms of the plan. If you or your eligible dependents elect to continue in the group health insurance plan, you will be charged the applicable premium. Failure to make timely payments may result in termination of coverage.

If this election for continuation coverage is made, you and your dependents may have the option to convert this coverage to an individual policy with our insurance carriers at the end of the continuation period.

The City will contact you concerning these options at the time termination occurs or your work hours are reduced. The City will contact your qualified beneficiaries in the event of your death or enrollment for Medicare benefits. However, if you become divorced or legally separated, or one of your dependents ceases to be eligible for coverage under our group health insurance plan, you and/or your dependent is responsible for contacting the City to discuss continuation/conversion rights. You and your qualified beneficiaries are also responsible for notifying the City within 60 days of qualifying for social security disability benefits.

## 5.3 FLEXIBLE SPENDING ACCOUNT

Full-time regular employees are eligible to participate in the City's **Section 125 Flexible Benefit Cafeteria Plan**. As a part of the City's **Section 125 plan**, any premiums you pay for medical or dental insurance will be deducted from your paycheck on a pretax basis.

Eligible employees may also contribute pretax dollars to a flexible spending account to pay medical costs not covered by insurance and/or dependent care expenses. The Payroll Office will distribute more information prior to the beginning of each plan year.

#### **5.4 DEFERRED COMPENSATION PLAN**

The City of Adel provides a deferred compensation investment plan for full-time regular employees. Employees may defer, or set aside, a portion of their paycheck and delay paying federal and state taxes on that amount, usually until they retire. Additionally, a Roth option is available for those who wish to contribute after-tax dollars. Details on the plan and other various investment options are available from the Finance Director.

#### **5.5 RETIREMENT**

Eligible employees participate in the Iowa Public Employees Retirement System (IPERS). This defined benefit plan provides a retirement benefit to eligible employees upon retirement in accordance with a formula that is currently based on your age, years of service, and the average of your highest five years of wages. All pension benefits and payroll deductions are subject to the requirements of the IPERS pension fund. For additional information, you should contact IPERS at 800-622-3849 or visit the IPERS website at [www.ipers.org/index.html](http://www.ipers.org/index.html).

#### **5.6 LENGTH OF SERVICE AWARD**

The City appreciates and recognizes the importance of your continuing service with the City. All employees will be presented a Service Award commemorating your service after your 5th, 10th, 15th, 20th, 25th and 30th years of employment with the City.

#### **5.7 EMPLOYEE TRAINING**

The City encourages its full-time regular employees to attend conferences, seminars, and training sessions of benefit to the employee in enhancing job performance, skills, and knowledge.

A request for approval to attend conferences, seminars or training sessions must be pre-approved by your direct supervisor. Please see the **Policy 2.04.01 - Travel Policy**. A Travel Request Reimbursement Form must be completed and contain signed approval prior to incurring the expense for which you are seeking reimbursement.

#### **5.8 TUITION REIMBURSEMENT / PROFESSIONAL DEVELOPMENT**

The City encourages full-time regular employees to improve their knowledge, abilities, and skills. Accordingly, an employee may be reimbursed for actual tuition costs not to annually exceed \$2,000. Upon the written request of an employee for educational leave and/or tuition reimbursement, the City Administrator or designee shall conditionally approve or disapprove

such a request and forward it to the City Council for final action. In addition to the prerequisite of City Council approval of the employee's request, the requesting employee shall be subject to the following requirements:

1. You must be a non-probationary full-time employee.
2. You must submit a written notice of intent to enroll in a timely manner that will allow the request to be included in the City's budget process. Generally speaking, your notice of intent to enroll must be submitted to the City Administrator or designee no later than December 31 for: (a) the fall semester of the following calendar year, and (b) the spring semester of the following school year.
3. You must submit a **Tuition Reimbursement Request Form**, before enrolling, to the City Administrator or designee for approval.
4. The course shall directly relate to your present position or a position you might attain with the City of Adel.
5. You must submit proof of course completion with a grade of a C or better.
6. Such work must be completed in an officially accredited educational institution or training program.
7. If you are receiving reimbursement for a college course, you are expected to continue working for the City a minimum of three (3) years after the completion of the course. If you terminate employment with the City prior to the three years, you are expected to reimburse the City for the full amount of the reimbursement received. You will be required to sign an agreement stating this prior to receiving any reimbursement for a college course.
8. Participation in the course shall be solely on [the](#) employee's time unless otherwise pre-authorized by the City Council.

The City Administrator or department head may approve other professional development seminars (i.e., certifications, CEUs, etc.) without City Council approval.

## 5.9 CLOTHING ALLOWANCE

### *Police Department*

The City will have the right to determine initial issuance of uniforms.

After one (1) year of employment, police officers will receive \$750 per year for a clothing allowance. The allowance will be given in two (2) equal installments (\$375 on January 1st and \$375 on July 1st).

Purchases allowed include the original uniform replacement (shirts, pants, ties, jackets, etc.).

An officer who fails to complete one (1) year of employment must return the initial issuance of uniforms to the Chief of Police.

### *Public Works Employees*

The City provides funding to order clothing for full-time regular and part-time regular public works employees. However, each year the City will reimburse each full-time regular and part-time regular public works employee up to \$150.00 for the purchase of work boots deemed necessary by the department head after employee provides a valid proof of purchase. Any amounts over \$150 during the rolling 12-month period shall be paid by the employee. In the event an employee's steel-toed safety boots are irreparably damaged or destroyed in a workplace accident prior to the expiration of the rolling 12-month period, that employee should contact the department head who may, in their discretion, approve a new \$150 safety boot allowance that would start a new rolling 12-month period.

**Commented [CE3]:** Do we need to add in anything about other departments?

**Commented [BS4R3]:** I believe we are on track, as this primarily focuses on boot reimbursement.

## **6. EMPLOYEE POLICIES**

### **6.1 JOB VACANCY & RECRUITMENT**

The City of Adel recruits the most qualified persons regardless of race, sex, sexual orientation, gender identity, genetic disposition, color, religion, age, ancestry, national origin, or disability (provided such disability does not interfere with job performance with reasonable accommodations).

The City will not hire relatives of full-time regular or part-time regular employees when employment would result in relatives working in the same department or place an employee in a position directly supervised by a relative. A more detailed description of the policy on hiring of relatives is found in section 6.13.

The City Administrator, in consultation with the Personnel Committee and department directors, determines whether each job classification is an open or promotional vacancy. Typically, promotional job classifications are those in which employees in a lower classification would gain the experience to qualify.

### **6.2 MEDICAL EXAMINATIONS**

The City may require you to submit to a job-related medical examination by a health care provider designated by the City. Medical examinations will be conducted after you have been offered a position and before you start work if the medical examination is required of all entering employees in the classification.

You may also be required to submit to a job-related medical examination when necessary to determine if you are still able to perform the essential functions of your position, and to any fitness for duty examinations required by federal, state or local law, or City policy. Also, voluntary medical examinations may be conducted as part of the City's employee health programs.

### **6.3 PROOF OF EMPLOYABILITY**

The City requires all employees to present documented proof of identity and eligibility to work in the United States. Each new employee must present the City with the necessary documents to verify the employee's identity and eligibility to work according to the laws of the United States, which typically include a driver's license and Social Security card. These documents will be inspected by the employer for their authenticity. The City and employee will complete the form I-9 to attest that the documents have been produced and inspected.

Additionally, the City utilizes E-Verify. E-Verify, authorized by Illegal Immigration Reform and Immigrant Responsibility Act of 1996 (IIRIRA), is a web-based system through which employers electronically confirm the employment eligibility of their employees.

#### **6.4 JOB POSTING**

The City of Adel, in its employment efforts, will post a notice in all departments, local newspapers, trade and professional journals for a period of ten (10) days.

#### **6.5 PERSONNEL RECORDS**

The City keeps a separate personnel file for each employee that includes the employment application, experience records, and other pertinent information in accordance with recordkeeping requirements and best practices in accordance with state and federal law. These files contain job-related information including payroll deductions, eligibility for benefit programs, compensation history, performance appraisals, disciplinary records, and other personnel related matters.

The City will generally release confidential personnel information only upon the written request and release of the Employee. The City will release non-confidential personnel information in accordance with applicable state law. The City will release any information relating to the results of federally required drug tests in accordance with the applicable law. Pursuant to Iowa Code section 22.7(11)(a)(5), if an employee is demoted, discharged, or resigns in lieu of being terminated, that fact is public record, as well as the documented reasons and rationale for the action.

If you are interested in reviewing the contents of your personnel file, you may do so at a time mutually agreed upon by you and the Finance Director or City Administrator. You will not have access to or be able to review letters of reference received or furnished by the employer or any reference check performed by the City. The Finance Director must be present during your review to preserve the security of your information. You may not remove any item from the file. However, you may, at your own expense, request and receive a copy of the contents of your file, except with respect to those items specified above. The City may charge a reasonable fee for copying the requested items.

Please note that this policy does not apply to any law enforcement files containing pre-hiring and psychological testing results that are required by law to remain confidential.

We would appreciate your help in keeping your records up to date. Please contact the Finance Director if you have any change in the following:

1. Name
2. Address / phone number / personal email address
3. Marital status
4. Beneficiaries
5. Dependents
6. Persons to be notified in the event of an emergency

#### **6.6 PROBATIONARY PERIOD**

Your first six months of employment are a time for both of us to get to know one another. This is intended to be a period in which you can learn the duties of your new job and in which management can evaluate your success in doing so.

Like any other employee, an employee who is currently working during a probationary period can be terminated from employment at any time with or without cause or prior notice during the probationary period. However, termination of employment during a probationary period is without appeal.

The supervisor will discuss with an employee whether he or she has successfully completed the probationary period before the close of business of the last day of the probationary period.

Furthermore, **successful completion of a probationary period does not change an employee's status as an employee at will.**

#### *Exceptions*

All new police officers shall be subject to a one-year probationary period following certification from the law enforcement academy. If a new employee has already been certified at the time of hire, his/her probationary period shall be one-year from date of hire. The probationary period for volunteer firefighters is six-months.

#### **6.7 HOURS OF WORK, LUNCH HOURS, & WORK BREAKS**

The regular workweek for all full-time regular employees, other than those in the Police Department, shall consist of forty hours. The established workweek shall run from 12:01 a.m. Sunday morning until 12:00 a.m. (midnight) the following Saturday night.

The appropriate department head shall determine specific work schedules including days and hours. Given certain departments must regularly operate seven (7) days per week, some employees may be required to work on any day of the week, but such employees will generally not be required to work more than two weekends per month. You are expected to be at your workplace in accordance with approved hours of work, holidays, and leaves. All non-exempt employees must accurately record their time on the appropriate timecard.

Public Works employees who are called back to work or called in to work prior to the normal starting time, other than due to the employee's negligence, will be compensated a minimum of two (2) hours unless such call back is two (2) hours or less prior to his/her shift, in which case the employee will be paid for actual hours worked at the appropriate rate. Call back does not apply when an employee is directed to work beyond his/her regular shift.

#### *Lunch Hours*

An unpaid lunch break approximately halfway through the work shift is allowed. The break is one-half hour for non-exempt employees and one hour for exempt employees. Your supervisor will advise you of your assigned time as the City must maintain adequate work coverage and give appropriate consideration to department needs and regulations.

#### *Work Breaks*

Each employee may take a 15-minute rest break in the morning and another in the afternoon. The direct supervisor is responsible for determining when and where employees take rest breaks. Rest break time does not accrue, if unused it is forfeited.

#### *City Hall Staff Hours*

City Hall staff shall work Monday through ~~Thursday-Friday, 7:30-15~~ a.m. to 4:45 p.m. and Friday 7:30 a.m. to 12:30 p.m. The City Administrator may allow for flexibility based on individual need and City operations for exempt employees.

#### *Police Department Hours*

The workweek for the Police Department will vary depending on the officer's schedule. Some Police officers work 5 days on / 2 days off and other officers may work 6 days on / 3 days off. The sixth day does not constitute overtime. Overtime is calculated based on hours worked in excess of the normal schedule.

### **6.8 OFFICE ENVIRONMENT**

It is important that your work area is kept neat and clean. We need your cooperation in meeting the City's objective of making the work place a pleasant and safe working environment.

## 6.9 INCLEMENT WEATHER

If the City Administrator announces by public broadcast that City offices are closed, then only persons designated as “essential personnel” need to report to work. Employees considered “essential personnel” will be notified by their supervisor if they are required to report to work.

All leave or absences due to inclement weather shall be unpaid unless the employee elects to take available vacation, compensatory time, or personal holidays with approval of the supervisor (and in accordance with a bargaining agreement, if applicable).

## 6.10 RESIDENCY REQUIREMENT

The City of Adel does not require its employees to be residents of the City. Nevertheless, the City of Adel may require that certain critical employees reside within a specified distance outside the City limits that allows them to report to work within a reasonable period of time. If for some reason you cannot meet this requirement, we ask that you consult with your supervisor. Also, some critical employees may have residency requirements written into specific City codes.

## 6.11 OUTSIDE EMPLOYMENT

You must inform your department director about any outside employment to avoid possible conflict with your City of Adel employment. If outside employment interferes with your work for the City of Adel, you will be asked to resign from one or the other position. In some instances, outside work is forbidden by City or state code. Before beginning any employment work outside of the City of Adel, you must complete the **Part-Time Job Notification Form** and obtain approval from the City Administrator or Chief of Police.

## 6.12 CITY EMPLOYEES AS PART-TIME FIREFIGHTERS

Full-time regular and part-time regular City employees who are secondarily members of the volunteer fire department and are firefighters and / or emergency medical technicians in the Fire Department may act as second responders to ambulance and first responders to fire calls while on duty if their normal work allows. They will receive only their primary job wages when responding during normal working hours. However, if the call they respond to overlaps their normal working hours, their pay for those extra hours will be provided under the normal fire department stipend policy. City vehicles may be used to respond to calls provided the employee is on duty.

## 6.13 HIRING OF RELATIVES

It is the policy of the City that applicants who are ~~immediate relatives-family members~~ of full-time regular or part-time regular employees shall not be hired, ~~appointed, in any capacity~~

(exception: volunteer firefighters and EMS personnel in the Fire Department) or transferred to any position in the same department when such employment that would result in:

1. Would result in relatives working in the same department. One family member being in a supervisory or administrative position over another immediate family member.
2. Would place an employee in a position where direct supervisory control would be exercised over or received from a relative.
3. Would place an employee in a position which would grant ~~g~~Granting one family member with access to confidential information concerning actual or potential administrative or disciplinary action to be taken against an immediate family member ~~relative~~.

Formatted: Indent: Left: 0.5", No bullets or numbering

Formatted: List Paragraph, Numbered + Level: 1 + Numbering Style: 1, 2, 3, ... + Start at: 1 + Alignment: Left + Aligned at: 0.25" + Indent at: 0.5"

Immediate family for purposes of this policy shall be defined as a spouse, child, parent, mother-in-law, father-in-law, daughter-in-law, son-in-law, brother-in-law, sister-in-law, grandparents, grandchildren, brothers and sisters or any member of the same household. Relative shall mean and include: the spouse of the applicant; a domestic partner; persons related to the applicant within the third degree (inclusive) by consanguinity; persons related to the applicant within the third degree (inclusive) by affinity, and their spouses; and those persons hereafter enumerated who are step-relatives of the applicant, and their spouses. Those in the following relationships to applicant shall be deemed "relatives" of the applicant for purposes of this policy: spouses of such persons; parents, sons, daughters, brothers, sisters, and the spouses of such persons; grandparents, grandchildren, and the spouses of such persons; nieces and nephews, great-grandparents, great-grandchildren, and the spouses of such persons; and persons in the same relationship to applicant's spouse as included in the above.

Employees A marriage of two employees within the same department who become immediate family members after their employment with the City has commenced and who would therefore ~~bc~~taking place after hire shall be considered a in violation of this policy and shall notify the employer and the employer will: require the termination of one of the two employees in one of the following ways: (1)

- 1- Have the subordinate employee reassigned to another supervisor; and/or (2) transfer one of the employees to a different department if an open position is available, the employee is qualified, and the approval of the department head is granted. If neither of those options are available, ~~Either~~ either of the employees may voluntarily resign from their position or, absent voluntary agreement, the least senior employee shall resign.
2. The least senior employee shall resign.
3. Either of the employees may be allowed to transfer to another department if a position is available, the employee is qualified, and the approval of the department head is granted. Such termination or transfer shall be effective not later than the date of the marriage.

Formatted: Normal, No bullets or numbering

It is within the discretion of the City Council to take action to grant an exception to this Policy.

**Commented [AH5]:** Does the City want to specify the right to grant an exception?

In addition, as provided by Iowa Code Chapter 71, it is unlawful for any person elected or appointed to any public office or position under the laws of the state to appoint as deputy, clerk, or helper in said office or position to be paid from the public funds, any person related by consanguinity or affinity, within the third degree, to the person elected, appointed, or making said appointment unless such appointment shall first be approved by the officer, board, council, or commission whose duty it is to approve the bond of the principal; provided this provision shall not apply in cases where such person appointed receives compensation at the rate of six hundred dollars per year or less. If Iowa Code Chapter 71 is amended, this policy will be amended to comply with the amended provisions of Chapter 71.

#### **6.14 VEHICLE & EQUIPMENT POLICY**

If an employee is required to operate a motor vehicle as part of his or her job duties, that employee must maintain a valid operator's license and be insurable under the City's liability policy as a condition of continued employment.

#### **6.15 VOLUNTARY RESIGNATION**

The City is proud of our low turnover, so before you consider resigning, please talk it over with your immediate supervisor. Sometimes a misunderstanding can be resolved. If you do decide to leave, you are required to give two to four (2 – 4) weeks advance notice to remain in good standing with the City. The amount of advance notice required depends on the position you hold with the City. Whether you provide proper advance notice of your resignation will be noted on your work record and used for reemployment consideration. In addition, if you fail to provide the appropriate advance notice, you will forfeit your ability to receive payment in your final paycheck for any accrued, unused vacation leave you have at the time of your separation.

It is your responsibility to notify the City of your resignation in a timely manner. If you fail to report to work and/or fail to communicate your work status to your Department Head by the beginning your third scheduled work day after giving notice of your resignation, it is grounds for termination of employment and will be considered a voluntary termination of employment. You also may not use earned leave time during the notice period unless you have received prior approval by the City Administrator. Your last day of employment with the City following your resignation will be considered your last actual working day when you are present.

1. Before leaving employment with the City, you are required to turn in all City property including, but not limited to, manuals, reference materials, keys, tools, equipment, computer hardware and/or software, and any other tangible City property.

## 6.16 OVERTIME & COMPENSATORY TIME

### *Overtime*

All employees are expected to work overtime when necessary and approved in advance by either the employee's supervisor or the City Administrator. Your supervisor will attempt to provide you with reasonable notice when the need for overtime work arises. Please remember, however, that advance notice may not always be possible.

All overtime requests must be approved prior to incurring the hours that would result in the payment of overtime or compensatory time. The employer has the right to direct the time of each work period depending upon weather conditions, emergencies, scheduling needs, etc.

Overtime pay calculated at one and one-half times an employee's regular hourly rate of pay will be granted to non-exempt employees who meet the following conditions:

1. For non-Police Department and non-Public Works employees, all hours worked in excess of forty (40) hours in a workweek. Time on paid or unpaid leave shall not be considered as time worked for the purpose of computing overtime.
2. For Public Works employees, all hours worked in excess of forty (40) hours in any workweek or eight (8) hours in a given day. Time on paid or unpaid leave will not be considered as hours worked for the purpose of computing overtime.
3. For Police Department employees, all hours worked in excess of the employee's scheduled shift (either 8 hours or 8.25 hours, depending on where the employee falls in the scheduled work cycle). In addition, the Department follows the guidelines established by the **Fair Labor Standards Act Section 7(k) exemption**. Time on paid vacation leave and/or sick leave shall not count as hours worked for the purpose of computing overtime; leave when an employee is using accrued compensatory time will be considered as hours worked for the purpose of computing overtime.

If a non-exempt employee, other than a police department employee, is required to work on an observed holiday, he/she shall be compensated at the time and one-half rate for all hours actually worked that day.

### *Compensatory Time*

In lieu of cash payments for overtime worked, non-exempt employees may accrue compensatory time off ("comp time") for overtime hours worked. Comp time will be accrued at the rate of time and one-half (1 ½) per overtime hour worked.

Exempt employees may receive administrative time, which is similar to comp time, for excess hours worked. However, administrative time is not time off that is accrued hour-for-hour whenever an exempt employee works beyond his/her regular ~~schedule;~~ schedule; it is simply a

means to allow management the discretion and flexibility ~~to~~ to grant additional leave to employees when appropriate for working extra time providing services for the City.

*Employee Selection of Pay or Comp Time*

Overtime shall be compensated in either cash or comp time at the employee's discretion. However, except as noted below, a non-exempt employee may only accumulate a maximum of forty-eight (48) hours of comp time. The employer may require comp time be used.

**6.17 PREGNANT WORKERS FAIRNESS ACT**

Under the Pregnant Workers Fairness Act, pregnant workers shall not be discriminated against based on their pregnancy or childbirth complications. Employees with needs related to pregnancy, childbirth, or related conditions (including lactation), may request a reasonable accommodation to enable them to perform their job. The City will provide reasonable accommodations for needs related to pregnancy, childbirth or a related medical condition so long as the requested accommodation does not impose an undue hardship on the City, and if the requested accommodation does impose an undue hardship the City will work with the employee in good faith to identify alternative accommodations that are equally effective and do not cause an undue hardship. The City will not deny employment opportunities or take adverse employment action against otherwise qualified applicants or employees who request or use such reasonable accommodations.

## 7. OCCUPATIONAL SAFETY AND HEALTH

The City of Adel makes every effort to keep your work area safe and free from hazard. The City makes every effort to comply with relevant federal and state occupational health and safety laws and to develop the best feasible operations, procedures, technologies, and programs conducive to such an environment.

### 7.1 SAFETY

The City Administrator and department heads are responsible for the fulfillment of departmental goals and objectives as well as the health and welfare of each employee in the department. In this safety policy, the highest priority has been placed on employee safety.

This priority is the responsibility of each department head. It is normal practice for the supervisors to be delegated the authority to carry out safety policies in his or her division, but the responsibility for meeting objectives and the protection of employees in performance of their assignments cannot be transferred.

It is the responsibility of every department to ensure a safe and healthful atmosphere, safe working conditions, tools, equipment, and work methods for all of its employees. Employees are expected to comply with all safety and health requirements whether established by management or by federal, state, or local law.

#### *City's Responsibilities*

In support of this policy, the City will:

1. Make every effort to comply with applicable local, state, and federal laws and regulations.
2. Establish safe work procedures and provide necessary personal protective equipment.
3. Provide funding for appropriate safety training.
4. Encourage employee involvement through a Safety Committee and support their efforts.
5. Investigate and evaluate all accidents to identify causation and identify corrective opportunities to prevent recurrence.
6. Conduct periodic facility safety inspections to identify unsafe conditions and at-risk behaviors.

7. Expect employees to observe all safety procedures and comply with established safety responsibilities outlined in this policy.
8. Establish requirements for work performed by contractors.

#### *Supervisors' Responsibilities*

Supervisors will actively support this policy as an example to those responsible to them. They have a direct responsibility for employee safety and for developing and maintaining a safe work environment.

As a supervisor your personal responsibility is the following:

1. To ensure employees follow all established safety procedures and practices. Provide counseling and administer disciplinary action when appropriate.
2. To provide ongoing employee training on safe work practices and procedures.
3. To investigate all injuries and accidents to identify causation and submit recommendations for preventing recurrence.

#### *Employees' Responsibilities*

Employees are required, as a condition of employment, to exercise due care in the course of their work to prevent injuries to themselves and to their fellow workers. Employees have a responsibility to report any unsafe working conditions or practices to a supervisor or safety committee. City employees are expected to work diligently to maintain safe and healthy working conditions and to adhere to proper operating practices and procedures designed to prevent injuries and illnesses. Each employee is expected to place safe work practices and identification of unsafe conditions as the highest priority while performing daily tasks.

The responsibilities of all employees of the City in this regard include:

1. Exercising maximum care and good judgment at all times to prevent accidents and injuries.
2. Reporting to supervisors and seeking first aid for all injuries, regardless of how minor.
3. Reporting unsafe conditions, equipment, or practices to supervisory personnel.
4. Using safety equipment provided by the City at all times.
5. Observing conscientiously all safety rules and regulations at all times.

6. Notifying their supervisors, before the beginning of the workday, of any medication they are taking, that may cause drowsiness or other side effects that could lead to injury to themselves or their coworkers.

Employees violating recognized safety rules, procedures, or standards, or acting in such a manner as to endanger their own or another's personal safety, shall be subject to disciplinary action, up to and including termination.

Each employee's safety commitment must include, but is not limited to, the following:

1. Follow all established safety procedures and ask your supervisor if they are not understood. Employees who ignore or violate these procedures may be subject to disciplinary action.
2. Using the safety equipment that has been provided for use in performing daily work assignments.
3. Wearing the prescribed uniform and safety shoes as required.
4. Not operating equipment for which no training or orientation has been received.
5. Warning coworkers of unsafe conditions or practices they are engaged in, which could lead to or cause an accident.
6. Reporting defective equipment immediately to a supervisor.
7. Reporting dangerous or unsafe conditions that exist in the workplace as well as throughout the City (e.g., defective sidewalks, broken curbs, hanging tree limbs, loose handrails, open manholes, sunken basins and sewers, missing or damaged traffic signs or signals, missing guards on operating equipment, etc.).
8. Reporting of all injuries and accidents regardless of severity.
9. Protect the public from any hazard that is a result of City work (e.g., street repair, sewer cleaning, main break work, etc.).
10. Taking care not to abuse tools and equipment, so that these items will be in usable condition for as long as possible as well as to ensure that they are in the best possible condition while being used.

## 7.2 WORK-RELATED INJURIES

To provide for payment of your medical expenses and for partial salary continuation in the event of an injury, occupational illness, or hearing loss in the course of employment, you are covered by workers' compensation insurance. The workers' compensation laws of the State of Iowa determine how employees receive medical care and how they are paid for lost work time as a result of a work-related injury or illness. The amount of benefits payable and the duration of payment depend on the nature of your injury or illness. In general, however, all medical expenses incurred in connection with an injury or illness are paid in full, and partial salary payments are provided beginning with the fourth consecutive day of your absence from work. During the first three days of absence, you will receive your normal compensation as an employment benefit. Employees with sick leave benefits may elect to use these benefit hours to make up the difference between their salary and the workers' compensation benefit amount.

If you are injured or become ill on the job, or incur an occupational disease or hearing loss, you must immediately report the condition to your supervisor, department head, or the City Administrator. The employee must complete a **State of Iowa "Employer's First Report of Injury"** through EMC OnCall Nurse. The employee must then report to a medical facility or hospital emergency room **of the City of Adel's choice** for treatment and care. In the event of a serious work-related injury or illness, report immediately to the physician, emergency room or medical facility, for prompt care and attention. This procedure ensures that the City can assist you in obtaining appropriate medical treatment. You are also expected to keep all physician appointments, follow physician's prescribed treatment, and adhere to restrictions both at and away from work. Your failure to follow these requirements may jeopardize your right to benefits in connection with the injury or illness. Questions regarding workers' compensation should be directed to the Finance Director.

The City also has a return to work program to provide guidelines for employees injured on the job who are unable to return to their regular job classification upon returning to work. See **Policy 2.01.01 – Return to Work Program** for details.

### *Accidents on the Job*

Accidents are instances whereby a City employee is injured, causes injuries to co-workers or private citizens, or causes damage to City or private property in the course of their normal business activities. Employees are responsible to report all accidents promptly to their immediate supervisor and fill out and file an incident report form. In some cases, accidents may require a briefing with the City Administrator and / or the department head.

## 7.3 INDIVIDUALS WITH DISABILITIES

The Americans with Disabilities Act (ADA) and the Americans with Disabilities Amendments Act, known as the ADAAMA, are federal laws that prohibit employers with 15 or more employees from discriminating against applicants and individuals with disabilities and that when needed

provide reasonable accommodations to applicants and employees who are qualified for a job, with or without reasonable accommodations, so that they may perform the essential job duties of the position.

It is the policy of the City to comply with all federal, state, and local laws concerning the employment of persons with disabilities and to act in accordance with regulations and guidance issued by the Equal Employment Opportunity Commission (EEOC).

Furthermore, it is our City policy not to discriminate against qualified individuals with disabilities in regard to application procedures, hiring, advancement, discharge, compensation, training or other terms, conditions and privileges of employment.

The City will reasonably accommodate qualified individuals with a disability so that they can perform the essential functions of a job unless doing so causes a direct threat to these individuals or others in the workplace and the threat cannot be eliminated by reasonable accommodation or if the accommodation creates an undue hardship to the City.

*Procedure for Requesting an Accommodation*

Qualified individuals with disabilities may make requests for reasonable accommodation to the City Administrator. On receipt of an accommodation request, the City administrator will meet with the requesting individual and the individual's supervisor to discuss and identify the precise limitations resulting from the disability and the potential accommodation(s) that the City might be able to make to help overcome those limitations.

The City Administrator, and, if necessary, a medical review officer and/or appropriate management representatives identified as having a need to know (e.g., the individual's supervisor/department head), will determine the feasibility of the requested accommodation, considering various factors, including, but not limited to, the nature and cost of the accommodation, the availability of tax credits and deductions, outside funding, the facility's overall financial resources and organization, and the accommodation's impact on the operation of the facility, including its impact on the ability of other employees to perform their duties and on the facility's ability to conduct business.

The City Administrator will inform the employee of the City's decision on the accommodation request or on how to make the accommodation. If the accommodation request is denied, employees will be advised of their right to appeal the City's decision to the City Council by submitting a written statement to the City Administrator along with the reasons for the request.

The City Council will review all employee appeals. After reviewing an employee's appeal, the City Council will notify the City Administrator of its decision, which will be final. The City Administrator will, in turn, notify the individual making the appeal of the Council's decision.

## **8. EMPLOYEE CONDUCT AND WORK RULES**

As an integral member of the City team, you are expected to accept certain responsibilities, adhere to acceptable business principles in matters of personal conduct, and exhibit a high degree of personal integrity at all times. To maintain a safe, efficient, and harmonious organization, the rules and regulations listed below have been established for City employees. This not only involves sincere respect for the rights and feelings of others, but also demands that both in your business and your personal life you refrain from any behavior that might be harmful to you, your coworkers, and / or the City, or that might be viewed unfavorably by the public at large.

Whether you are on or off duty, your conduct reflects on the City. You are, consequently, encouraged to observe the highest standards of professionalism at all times. Each rule reflects a common understanding of what behavior is acceptable for City employees, but these rules are not necessarily the only areas in which disciplinary action may be taken if conduct or circumstances require. These rules may be modified by the City as changing conditions warrant. The City may take whatever disciplinary action it deems appropriate in response to an offense, even if it is not included in the following list. You must also understand that any offense, whether or not it is included in these work rules, may result in disciplinary action, up to and including discharge, without prior warning.

**While it is not possible to list all the offenses for which an Employee will be disciplined, the following are examples of inappropriate, unacceptable conduct that will result in discipline to the employee, up to and including termination from employment with the City:**

1. Theft or willful destruction of property of the City or any employee.
2. Falsifying or supplying false information for the completion of City records.
3. Violating the City's nondiscrimination and/or sexual anti-harassment policy (**Policy 2.02.01**).
4. Use of official position for personal advantage or gain.
5. Wasting time during the workday.
6. Insubordination or refusing to perform work or reasonable instructions.
7. Possession or use of intoxicants or narcotics on City property.
8. Possession of explosives, firearms, or other concealed weapons on the City premises without permission.

9. Intentional punching of another employee's timecard or alteration of timecard.
10. Sleeping during working hours.
11. Soliciting or accepting gratuities from citizens for the performance of your job.
12. Stealing property from coworkers, citizens, or the City.
13. An employee determined to be an aggressor in a fight on City premises.
14. Conviction of a crime carrying a penitentiary sentence.
15. Leaving work site during working hours without signing out, unless with authorized permission or performing activities related to the employee's job.
16. Reporting to work under the influence of intoxicants or narcotics.
17. Disorderly conduct including use of profane or abusive language, intimidating, threatening, or provoking fellow employees, or other acts showing lack of respect for other people and property.
18. Deliberate defacing of bulletin boards, material thereon, walls or other properties of the City or fellow employees.
19. Working on personal unrelated work duties on City time.
20. Engaging in excessive, unnecessary, or unauthorized use of City's supplies, particularly for personal purposes.
21. Sabotage, causing damage or destruction of tools, equipment, or other property belonging to the City or fellow employees.
22. Failure to comply with a request of supervisory personnel to submit personal packages being brought onto or out of the work site for inspection.
23. Unauthorized altering or repairing of equipment.
24. Incompetence, inefficiency, or negligence in the performance of duty.
25. Soliciting, collecting, distributing, or selling on City time without authorization.
26. Soliciting, collecting, distributing, or selling City property without written authorization.

27. Unauthorized operation of equipment or use of material or property of City or fellow employees.
28. Smoking in restricted areas.
29. Willful violation of safety and health requirements.
30. Habitual tardiness or absences without just cause.
31. Horseplay including running, pushing, shoving, throwing objects, playing practical jokes, and otherwise disturbing fellow employees.
32. Failure to call and notify the City of an absence prior to the start of work.
33. Leaving workstation unnecessarily.
34. Failure to fill out employee's own timecard in accordance with standard procedure.
35. Failure to be at the work site at starting time or stopping before quitting time.
36. Unauthorized parking, excess speed, or other acts of disregard for fellow employees in moving traffic on City property.
37. Unauthorized use of City telephones except in case of emergencies.
38. Impeding, obstructing, or failing to cooperate with an inquiry or investigation conducted by the City.

## **8.1 DISCIPLINARY POLICY**

Discipline is necessary for the efficiency of the City's operations. If your performance, conduct, work habits, overall attitude, or demeanor becomes unsatisfactory in the judgment of your supervisor or other management, whether based on any of the items listed in the immediately preceding section of this handbook, or any other City policies, rules, regulations, or conduct in which you engage, you will be subject to disciplinary action, up to and including possible termination of employment.

This policy establishes broad guidelines designed to achieve fair and equitable treatment of employees. It does not, either by itself or in conjunction with any other City documents, policy, practice, procedure, or verbal statement, create an employment contract, express or implied, or define the employment relationship. It does not establish a rule that requires progressive discipline, or create a contract that employment will not be terminated except for certain offenses or only after certain disciplinary steps have been taken or warnings issued. The City reserves the

right to change this policy from time to time as needs dictate, and to deviate from these guidelines to appropriately address the circumstances of each situation.

Whenever an employee's performance, work habits, attitude, or demeanor becomes unsatisfactory in the judgment of the City, based on violations of either the rules listed above, or other City policies, rules, procedures, or expectations, you will be subject to disciplinary action, up to and including discharge. Certain offenses, if appropriate and justified under the circumstances, may be corrected using progressive discipline:

1. Oral reprimand or warning
2. Written reprimand or warning
3. Suspension with loss of pay
4. Demotion
5. Discharge

If appropriate and justified under the circumstances, following a discussion of the matter, a reasonable time for improvement or correction may be allowed before any further disciplinary action is initiated. In situations where an oral warning has not resulted in the correction of the condition, or where more severe initial action is warranted, the supervisor will have discretion to utilize one of the other available disciplinary measures. Documented oral warnings and written warnings shall be provided to the employee and a copy placed in the employee's personnel file.

In those cases where one or more written reprimands have not proven to be effective, or in those cases where the seriousness of the events or conditions warrant it, and the supervisor desires to impose discipline more severe than a written warning, including suspensions, demotions, and termination, the matter shall be determined by the City Administrator or Police Chief for police department staff. An employee desiring to appeal the decision of the City Administrator or Police Chief shall go directly to Step Three of the Grievance Procedures in section 10.

The City reserves the right to use whatever discipline it decides is appropriate in any situation, up to and including discharge, without regard to the general discipline guidelines explained above.

Employees are free to resign their employment with the City at any time and for any reason and the City retains the same right regarding termination of employment.

## **8.2 ABSENTEEISM & TARDINESS**

The City expects all employees to assume diligent responsibility for their attendance and promptness. Recognizing, however, that illnesses and injuries may occur, the City has established sick leave and disability benefits plans to compensate full-time regular employees for certain time lost for legitimate medical reasons, including time off to secure necessary treatment. Prorated sick leave has been established for part-time regular employees. (Please consult the appropriate sections of this handbook for information regarding these benefits.)

If you must be absent because of illness or any other cause, you must notify your supervisor by your regularly scheduled starting time or as soon thereafter as possible on each day of your absence unless you are granted an authorized medical leave, in which case different notification procedures apply. Failure to properly notify City management results in an unexcused absence. The same procedure applies if you find that you are going to be late.

Your attendance record will be taken into consideration during performance appraisal review. Absenteeism or tardiness that is unexcused or excessive in the judgment of the City is grounds for disciplinary action, up to and including dismissal.

## **8.3 PERSONAL APPEARANCE AND Demeanor**

All employees represent the City. Your neat appearance and dress must be consistent with job responsibilities. They help to create a professional atmosphere and reflect a good image of the City and you as an individual.

Discretion in style of dress and behavior is essential to the efficient operation of the City. Employees are, therefore, required to dress in appropriate casual business attire appropriate to the position and to behave in a professional, businesslike manner. Please use good judgment in your choice of work clothes and remember to conduct yourself at all times in a way that best represents you and the City of Adel.

Employees are also required to keep their work environment clean and orderly. Before departing at the end of their workday, employees should lock all files and cabinets and clear all work materials from desk surfaces, especially materials of a sensitive or confidential nature.

Employees failing to adhere to proper City standards with respect to appearance and demeanor are subject to disciplinary action.

## **8.4 ELECTRONIC COMMUNICATION**

### *Purpose*

The purpose of this policy is to provide guidelines regarding the use of the City's electronic communication systems. For the purposes of this policy, electronic communication includes, but

is not limited to, email, Internet access, voicemail, text messaging, audio and video conferencing, and facsimile messages.

This policy has been adopted to protect City employees who use the electronic communication systems and to protect the City. Inappropriate use of electronic communication may result in embarrassment to the City of Adel and to you.

This policy is applicable to all City employees and officials.

#### *Usage*

Employees are encouraged to utilize electronic communication as an appropriate means of communication and research to improve the quality and productivity of employees. Employees shall use these services responsibly and limited primarily to City business purposes.

Non-exempt employees shall not engage in work-related e-mail during non-work hours unless previously directed by the employee's department head or designee.

All electronic and telephonic communication systems and all communications and information transmitted by, received from, or stored in these systems are the property of the City.

Employees are not permitted to use a code, access a file, or retrieve any stored communication unless authorized to do so or unless they have received prior clearance from an authorized City representative.

Employees who are terminated, laid off, or on an extended leave of absence have no rights to the contents of their email messages and are not allowed to access the City's electronic communication systems.

#### *Privacy*

The City reserves the right to monitor electronic communication without prior notification to employees. Users should have no reasonable expectation of privacy in the use of these resources. All electronic communication systems are subject to all state and federal rules and laws, including the **Electronic Communications Privacy Act of 1986**.

All passcodes and passwords are the property of the City. No employee may use a passcode, password, or voicemail access code that has not been issued to that employee or that is unknown to the City.

To ensure that the use of electronic communication systems and business equipment is consistent with the City's legitimate governmental interests, authorized representatives of the City may monitor the use of such equipment from time to time.

### *Public Information*

Electronic communication is considered to be a public record and may be subject to public disclosure in accordance with applicable law.

### *Security*

Email, Internet access, and other electronic communication systems may not be secure. This is true for the City's systems as well. Employees using electronic communications systems should assume that their messages can be intercepted or monitored by unauthorized persons.

**Employees using passcodes are required to keep them confidential as they are responsible for the information a password is designed to protect.**

### *Digital Devices*

The Mayor, City Council, City Administrator, authorized Department Heads, and authorized City Staff are provided a digital device from the City. These devices are the property of the City, and those employees or officials that are assigned such devices are bound by this Electronic Communication Policy and all other applicable policies.

The devices must be properly maintained, in clean and working fashion, and not to be exposed to materials or elements that may lead to damage of the devices. In the event that your assigned device becomes damaged, you must immediately report the damage to the City Administrator.

When a device has been lost, stolen, or damaged, the City shall bear the full cost of repairing or replacing the device. If the device is lost, stolen, or damaged (not including hardware or software system malfunctions) a second time, the City shall bear half the cost of repairing or replacing the device, and the employee or official who has been assigned the device shall bear half the cost. If the device is lost, stolen, or damaged three or more times (not including hardware or software system malfunctions), the employee or official who has been assigned the device shall bear the full cost of repairing or replacing the device. If the device is damaged and under warranty, the repair or replacement of the device shall proceed according to the warranty.

You must create an individual, dedicated sign-on password for your assigned device and keep it on file with the City Administrator and IT staff. The City will create a password for you if you do not make one yourself. No employee or official may use a different password or alter their password unless the new password is provided to the City Administrator and IT staff.

The device may only be used by the employee or official to which that device was issued and assigned.

Personal correspondences, including emails or text messages, sent and received from the digital devices may be subject to public disclosure. Any notes or documents created or edited on the digital devices may also be subject to public disclosure.

In order to limit the perception of wrongdoing, instant messaging, email, or other digital correspondence of any form between members on the digital devices shall not be permitted during a bona fide meeting of the Council, its committees, or any commission or board meeting.

Within three days of an employee or official's separation from the City, the device shall be returned to the City. The employee or official shall not tamper with, delete, or remove any content from the device prior to turning it in. Once the City has received the device, the City shall back it up and "wipe" it (remove all content) or restore it to its factory settings.

*Permissible Use*

Employees shall use the electronic communication systems primarily for the purpose of conducting City business relating to the mission, function and work tasks of the City of Adel. Provisions for incidental personal use are outlined later in this policy.

*Prohibited Uses*

The City of Adel's electronic communication systems may not be used for illegal or wrongful purposes. Several examples of prohibited activity are listed here:

1. Infringe the copyright or other intellectual property rights of third parties.
2. Violate or infringe on the rights of any other person, including the right to privacy.
3. Distribute defamatory, false, inaccurate, abusive, obscene, pornographic, profane, sexually oriented, threatening, racially offensive, or otherwise biased, discriminatory, or illegal material.
4. Violate City regulations prohibiting sexual harassment.
5. Content that promotes, fosters, or perpetuates illegal discrimination of any kind.
6. Restrict or inhibit users from using the system or the efficiency of the electronic communication systems.
7. Solicit funds.
8. Gamble.
9. Promote or distribute political messages.
10. Conduct "spoofing," in which you construct your message so that it appears to be from someone else.

11. Attempt unauthorized access to data, breach security, or intercept any electronic communication on any system without proper authorization

#### *Personal Use*

Employees may use electronic communication systems for personal use provided that the following guidelines are met:

1. It is incidental.
2. It does not interfere with the job performance of the employee or co-workers.
3. It does not generate a direct cost to the City.
4. It is outside of work hours. (i.e. break, lunch, before or after work)

#### *Violations*

The use of the City's electronic communication systems is a privilege afforded to authorized users. This privilege may be revoked at any time for violations of this policy.

The City Administrator or Police Chief will evaluate violations of this policy on a case by case basis. Employees found to have violated this policy, or to have engaged in illegal or unethical practices, will be subject to disciplinary action, which could include termination of employment and criminal prosecution.

### **8.5 HARASSMENT**

The City of Adel is committed to providing all of its employees with a workplace free from harassment. The City maintains a strict policy prohibiting sexual harassment and harassment on the basis of sexual orientation, gender identity, race, color, national origin, religion, sex, physical or mental disability, age, marital status, veteran status or any other characteristic protected by applicable laws. This prohibition applies to all employees, volunteers, vendors, residents, or citizens of the City. No employee of the City of Adel is expected to tolerate any conduct prohibited by this policy from anyone while at work or engaged in City business.

#### *Sexual Harassment*

See **Policy 2.02.01 – Sexual Anti-Harassment Policy** for details.

#### *Other Types of Harassment*

The City also prohibits other forms of harassment on the basis of race, color, national origin, religion, gender, sexual orientation, gender identity, physical or mental disability, age, marital status, veteran status or any other characteristic protected by applicable laws. Such prohibited harassment includes, but is not limited to, the following:

1. Verbal conduct such as threats, epithets, derogatory comments, or slurs.
2. Visual conduct such as derogatory posters, photographs, cartoons, drawings, or gestures.
3. Written communications containing statements that may be offensive to individuals in a particular protected group, such as racial or ethnic stereotypes or caricatures.
4. Physical conduct such as assault, unwanted touching or blocking normal movement.
5. Retaliation for making harassment reports, threatening to report harassment, or participating in a harassment investigation.

#### *Harassment Complaint Procedure*

Any employee who believes he or she has been subjected to harassment prohibited by this policy should immediately report that behavior to the City Administrator, Finance Director, or any department head with whom the employee works.

If an employee becomes aware of harassing conduct engaged in or suffered by a City employee, regardless of whether such harassment directly affects that employee, the employee should immediately report that information, preferably in writing, to the City Administrator, Finance Director, or any department head with whom the employee works.

Whenever the City is made aware of a situation that may violate this policy, the City will conduct an immediate, thorough, and objective investigation of any harassment claims. If the City determines that prohibited harassment has occurred, it will take appropriate action against any person found to have engaged in prohibited harassment. A determination regarding the alleged harassment will be made and communicated to the person claiming harassment as soon as practical. The type of discipline administered will be dependent upon the severity of the conduct, as well as any other factors presented in the particular circumstances. Employees violating this policy are subject to discipline up to and including termination.

#### *Whistleblower Policy*

The City strictly prohibits retaliation against any person by another employee or by the City for using this complaint procedure, reporting harassment, or for filing, testifying, assisting, or participating in any manner in any investigation, proceeding, or hearing conducted by the City or a governmental enforcement agency. Prohibited retaliation includes, but is not limited to, termination, demotion, suspension, failure to hire or consider for hire, failure to give equal consideration in making employment decisions, failure to make employment recommendations impartially, adversely affecting working conditions, or otherwise denying any employment benefit.

The City does not consider conduct in violation of this policy to be within the proper course and scope of employment and does not sanction such conduct on the part of any employee, including management employees.

## **8.6 DRUG FREE WORKPLACE**

### *Policy*

It is the policy of the City of Adel to comply with the **Drug Free Workplace Act of 1988 (Public Law 100-690)** and to ensure a drug-free workplace. This policy is intended to ensure that the mental and physical capabilities of City employees are not impaired by any controlled substances during the performance of their duties.

### *Procedures*

As a condition of employment each employee is required to abide by the following terms:

1. All full-time, part-time, and paid on call prospective employees who hold a safety-sensitive position identified by the City will be required to pass a drug screen test following a conditional offer of employment with the City.
2. Prospective employees who refuse to take the required drug test, or who fail to cooperate in any aspect of the testing procedure, or who test positive for any of the drugs being screened for will be ineligible for City employment and will be removed from all eligibility lists.
3. City employees may not manufacture, distribute, sell, dispense, possess, consume, or use controlled substances in the workplace, or while in the course of his or her employment, or reasonably prior to or during work time, during work breaks, or during the lunch hour, when such employee will, or can reasonably be expected to be, back on the job undertaking work duties immediately following such work break or lunch period. For the purposes of this policy, controlled substances shall be deemed to include alcohol, barbiturates, narcotics, tranquilizers, amphetamines, hallucinogens, marijuana, and all other substances so defined in federal and state criminal statutes.

### *Safety-Sensitive Positions*

Safety-sensitive positions include but are not limited to all of the following:

1. All patrol and investigative police positions, and other police positions as deemed necessary by the Chief of Police.
2. Fire fighter positions.
3. Lifeguard staff.

4. All other employees who will operate heavy equipment, machinery, and/or drive a City-owned vehicle during the course of their normal work duties and/or other positions as identified by the Personnel Committee.

#### *Conditions of Employment*

As a condition of employment, every employee who is employed by the City of Adel is required to abide by the following conditions:

1. Employees shall refrain from the unlawful manufacture, distribution, dispensing, possession, or use of controlled substances in the workplace.
2. Employees are required to report any arrest or conviction under a criminal drug statute for violations occurring either on or off the employer's premises to the employee's supervisor or other appropriate City official within 5 days of such arrest or conviction. Employees who violate any aspect of this policy may be subject to disciplinary action up to and including termination. At its discretion, the City may require employees who violate this policy to successfully complete a drug abuse assistance or rehabilitation program as a condition of continued employment.
3. In the event that a department head receives notice under the preceding paragraph, the City Administrator or a designated representative shall:
  - a. Notify the appropriate federal agency or agencies providing federal funds, if any, within 10 days of a reported conviction.
  - b. Take appropriate disciplinary action against any employee violating this policy, including the termination of employment, or, in lieu thereof, requiring that the employee complete a substance abuse rehabilitation program approved by the City.

#### *Drug Awareness Program*

The City Administrator is authorized to establish a drug awareness program to inform employees about the following:

1. The dangers of controlled substances in the workplace.
2. The City's policy of maintaining a drug-free workplace.
3. Available counseling and rehabilitation programs.
4. The penalties that will be imposed for violating this policy.

*Exceptions*

1. The policy described shall not be deemed to be applicable to any employee taking a prescribed dosage of a controlled substance while under the care of a licensed physician.
2. Nothing in this policy shall be deemed to preclude the possession of controlled substances by employees of the Public Safety Department where such possession is necessary in connection with the carrying out of such employee's law enforcement, investigative, or emergency medical treatment and response duties and where such possession is in accordance with all rules, regulations, and policies of the Public Safety Department and with all other applicable local, state, and federal statutes, rules, and regulations.

*Acknowledgement*

The City Administrator will give notice to all employees of the adoption of the policy outlined, and to further obtain from each employee an acknowledgement of their being notified of such policy. Employees must sign and return the **Drug Free Workplace Acknowledgement Form**.

**Commented [CE6]:** ??????

**Commented [BS7R6]:** We do have an acknowledgment form, although it needs to be updated. Moving forward, I recommend including it in our new hire packets.

**8.7 SMOKING**

Smoking is not allowed anywhere inside City buildings, grounds (unless in a designated area), vehicles or equipment. Any employee who violates this policy will be subject to disciplinary action, up to and including discharge.

All City workers, visitors, and members of the general public must comply with Iowa's Smokefree Air Act. See Iowa Code Chapter 142D. Additionally, no person shall smoke or use tobacco (including e-cigarettes or vaping devices) in any public building, including City-owned, operated, and/or leased space in buildings and offices, including elevators, stairways, hallways, restrooms, break rooms, conference rooms, or lounge areas.

No person shall smoke or use tobacco in any City-owned, operated and/or leased vehicle or equipment, including cars, trucks, vans, heavy equipment, lawn mowers, etc.

**8.8 INVESTIGATIONS**

All employees are required to fully cooperate with any member of management, or designee, who is conducting a work-related investigation. Employees will be disciplined for lying to any member of management or providing information to any member of management that is dishonest, misleading, inaccurate, or incomplete.

Employees will also be disciplined for impeding, obstructing, or failing to cooperate with an inquiry or investigation conducted by any member of management, or designee. "Obstructing" includes, but is not limited to, threatening, intimidating, or coercing other individuals who may be contacted by management, and discouraging other individuals who may be contacted by

management from responding to or cooperating with management. “Failing to cooperate” includes, but is not limited to, failing to provide information, documents, or materials requested by management, and providing information, documents, or materials to management that are dishonest, misleading, inaccurate, or incomplete.

## 9. PERFORMANCE APPRAISAL

Performance evaluations will give you an opportunity to discuss your development with your supervisor. To ensure that you perform your job to the best of your abilities, it is important that you be recognized for good performance and that you receive appropriate suggestions for improvement when necessary. This will allow you to know where you stand in relation to the job requirements. Each supervisor is responsible for the timely and proper completion of an employee performance review and evaluation report.

Performance reports shall be made on the standard form provided by the Finance Director or City Administrator and must be submitted at the specified times:

1. At the end of the probationary period.
2. Annually.
3. Any other interval deemed necessary and/or appropriate by the City Administrator.

All written performance reviews will be based on your overall performance in relation to your job responsibilities and will also take into account your conduct, demeanor, and record of attendance and tardiness.

In addition to the regular performance evaluations described above, special written performance evaluations may be conducted by your supervisor at any time to advise you of the existence of performance or disciplinary problems.

A new police employee will be evaluated every year. The first year for a new police officer includes successful completion of an approved Law Enforcement Academy. The Iowa Law Enforcement Academy shall determine whether a cadet is approved.

In the event the supervisor does not complete timely performance appraisals, it is the employee's responsibility to bring this to the attention of the supervisor. If the appraisal is not done within ten days of the employee's complaint, the employee shall bring the matter to the attention of the City Administrator or, in the case of the police ~~department~~ ~~those~~ ~~department~~ or those supervised by the City Administrator, the Mayor.

## 10. GRIEVANCE PROCEDURES

**NOTE: This Complaint Resolution Procedure DOES NOT APPLY to complaints concerning discriminatory or harassing conduct. Please see Policy 2.02.01 – Sexual Anti-Harassment Policy for the appropriate complaint procedure for these issues. This procedure also does not apply to the wage process policy, for which there is not an avenue of appeal.**

The most important resource to the City of Adel is its employees. Sometimes, all of us experience some type of problem in the workplace. Misunderstandings or conflicts can arise in any organization. We have a problem-resolving procedure that will assure you that your problem will be heard, and appropriate action will be implemented. To ensure effective working relations, it is important that such matters be resolved before serious problems develop. Most incidents resolve themselves naturally; however, if a situation persists that you believe is detrimental to you or the City, or in which you feel a City policy has been violated, you should follow the procedure described here for bringing your complaint to management's attention. The City will act in good faith to resolve any grievance presented by an employee through this process.

### *Step One*

Discussing the problem with your department head is a necessary first step. Discussion of the problem shall be brought to the attention of the department head within two (2) working days of the incident. Working days are defined as Monday through Friday, excluding weekends and non-working holidays. If, however, the issue is not resolved to your satisfaction at the time of the discussion, you shall notify the department head that you are going to proceed to Step Two. A department head wishing to file a complaint should proceed to Step Three.

### *Step Two*

The employee having a specific complaint shall submit it in writing to his or her department head within five (5) working days of Step One. In an effort to resolve the problem, your department head will consider the facts, conduct an investigation, and also shall meet with you and your supervisor (if applicable) in an attempt to resolve the issue. The department head will respond to all parties involved in writing regarding the issue within the department head's next five (5) working days after receipt of your written grievance.

### *Step Three*

Within five (5) working days after the decision in Step Two, if you are not satisfied with the decision and wish to pursue the complaint further, you may present your written grievance to the City Administrator, who will then call a meeting of the Complaint Resolution Committee. This three-person committee will be chaired by the Mayor and be comprised of the chairperson of the Personnel Committee and a department head designated by the Mayor (other than the complainant's department head).

The Complaint Resolution Committee shall meet within seven (7) working days to discuss and attempt to resolve the issue according to the policies of the City of Adel. The complainant, as well as his or her supervisor and / or department head, shall attend the meeting to discuss all issues. The Committee will render its decision in writing within five (5) working days to all parties involved.

*Step Four*

If you are unsatisfied with the decision of the Complaint Resolution Committee, you may submit your written request to the City Administrator within five working days for a hearing of the City Council. The request shall include your written grievance, all responses, and investigation materials. The request may include a request for a closed session. The City Council will schedule the hearing at its next meeting. Both the complainant and his or her supervisor or department head shall be available for the hearing. The decision of the City Council shall be final and binding. If the City Council elects not to act on the complaint after hearing, the decision of the Complaint Resolution Committee shall be final and binding.

**The City does not tolerate any form of retaliation against employees availing themselves of this procedure. Any employee engaging in, or who encourages others to engage in, any retaliatory conduct against any employee who utilizes this procedure or who assists others in using this procedure, or who participates in an investigation of a grievance, shall be subject to discipline, up to and including possible termination of employment.**

**This procedure shall not be construed as preventing, limiting, or delaying the City from taking disciplinary action against any individual, up to and including termination, in circumstances where the City deems disciplinary action appropriate.**

Grievances involving bargaining unit employees shall be covered by any grievance language in bargaining agreements.

## **11. CAMPAIGN AND ETHICS GUIDELINES**

### **11.1 CAMPAIGN ACTIVITIES**

We encourage you to vote in public elections, which is an expression of your personal opinion. However, pursuant to Section 721.3 of the Iowa Code, candidates or committee members cannot solicit contributions or receive political support from you during work hours.

Employees may voluntarily participate in, or contribute to, the election or appointment of public officials. Political activity, however, must not interfere with your normal work duties. No City employee will be forced or compelled to take part in political campaigns to favor the appointment or election of candidates for any office.

The use of any City equipment, including, but not limited to computers, printers, copy machines, postage, and machines and other equipment for the purpose of promoting a specific candidate or political action committee violates Chapter 68A of the Iowa Code. For questions regarding use of public buildings and facilities, refer to Iowa Code chapter 68A and/or contact the Iowa Ethics & Campaign Disclosure Board (<https://ethics.iowa.gov/>).

### **11.2 CANDIDATES FOR OFFICE**

If you become a candidate for any City elective office, you automatically receive a leave of absence without pay. The leave without pay begins upon either an announcement of your candidacy or filing of a petition for office. However, this will not be later than 30 days before the primary or general election day, and it continues until you are no longer a candidate.

If elected, you are required to resign your City position. However, you may be a candidate for a non-partisan office that is not related to your employment. If this is the case, you will not be required to take the leave of absence without pay, as long as you do not campaign while you are on duty as an employee or let your duties interfere with your City job responsibilities.

### **11.3 GIFT & IN-KIND CONTRIBUTIONS**

As an employee of the City of Adel, you shall not directly or indirectly accept or receive any gift or series of gifts, as defined in Chapter 68B of the Code of Iowa.

## STATEMENT OF RECEIPT

Please read and sign this Statement of Receipt and return the completed sheet to the Finance Director for placement in your official personnel record.

*I have received my copy of the 2023~~4~~ City of Adel Employee Handbook that outlines personnel policies of the City, and the Manual of Policy and Procedure and all policies per the table of contents. I will familiarize myself with the material in the handbook and understand that I am governed by its contents.*

*I understand that:*

- 1. These policies affect all City employees, except for some minor differences that may pertain to employees who are working under contract terms, or employees working under a collective bargaining agreement.*
- 2. Nothing in the Employee Handbook or Manual of Policy and Procedure is considered as an explicit or implicit employment contract between the City and me.*
- 3. Unless prohibited by the Code of Iowa or expressly agreed and confirmed in writing by both the City, and myself, either the City or myself may terminate my employment at any time for any reason.*
- 4. The City may change, rescind, or add to any policies described in the Employee Handbook or Manual of Policy and Procedure at its discretion.*

Your Signature:	
Your Name (please print):	Date:

## **Brittany Sandquist**

---

**From:** Brittany Sandquist  
**Sent:** Tuesday, May 21, 2024 1:14 PM  
**To:** Aaron Hilligas  
**Cc:** Carrie Erickson  
**Subject:** FW: CORRECTION: Ahlers Alert: Recent Employment Law Updates

Good Afternoon, Aaron,

Should we consider incorporating language regarding the Pregnant Workers Fairness Act into our employee handbook?

### **Brittany Sandquist**

Deputy City Administrator/Finance Director  
City of Adel

P.O. Box 248  
301 S. 10<sup>th</sup> Street  
Adel, IA 50003

(515) 993-4525  
(515) 993-4527 (F)

[www.adeliowa.org](http://www.adeliowa.org)

**Adel City Hall has *new* hours to better serve our residents!**

**Mondays – Thursdays: 7:30 a.m. to 4:30 p.m.**

**Fridays: 7:30 a.m. to Noon**

---

**From:** Ahlers & Cooney, P.C. <info@ahlerslaw.com>  
**Sent:** Monday, May 13, 2024 12:16 PM  
**To:** Brittany Sandquist <bsandquist@adeliowa.org>  
**Subject:** CORRECTION: Ahlers Alert: Recent Employment Law Updates

**CAUTION:** This email originated from outside the City of Adel's internal network. Do not click links, open attachments, or process requests unless you recognize the sender, know the content is safe, or verify that the request is authentic.



**AHLERS COONEY**  
ATTORNEYS

## CLIENT ALERT

### RECENT EMPLOYMENT LAW UPDATES

By attorneys *Emily Ellingson, Rachel Fritz and Rebecca Reif*

**CORRECTION:** Please note that we had a typographical error in the bulleted list of dates in this alert that was sent this morning. We apologize for this and ask that you delete the prior email and only refer to this corrected alert. Thank you!

In recent months, there have been significant changes to legal and regulatory requirements impacting employers. Some of the more significant changes include modifications to the salary requirements for employees under the Fair Labor Standards Act, updated rules prohibiting non-compete agreements with employees, and new legislation impacting pregnant workers. See below for more information regarding these changes.

#### **“Salary Threshold” for FLSA Exemptions Increased**

On April 23, 2024, the U.S. Department of Labor issued a final rule under the federal Fair Labor Standards Act (the “FLSA”) which will raise the salary threshold for “executive, administrative, and professional” (“EAP”) and “highly compensated” exempt employees in the United States. The rule not only changes the current salary threshold amount but also builds in future automatic increases to these salary thresholds, in order to keep up with

workplace and economic changes without regulatory rulemaking. This final rule will become effective on July 1, 2024.

The major changes include:

- An increase in the salary threshold for EAP exempt employees to **\$844 per week, or \$43,888 annually, as of July 1, 2024;**
- An increase in the salary threshold for EAP exempt employees to **\$1,128 per week, or \$58,656 annually; as of January 1, 2025;**
- An increase in the salary threshold for the “highly compensated” employee exemption to \$132,964 annually as of July 1, 2024, and \$151,164 annually as of January 1, 2025;
- A self-adjusting increase to both of these thresholds every three years, starting on July 1, 2027, based on current wage data.

However, the new rule will not:

- Change the “primary duties” tests for EAP exempt employees;
- Affect exemptions from overtime for positions without a salary threshold, or with a special salary threshold, including specifically *teachers, doctors, lawyers, or academic administrative professionals* employed at educational institutions.

If you have employees who you have treated as exempt but do not meet the new salary thresholds, now is the time to plan for how you will comply with the new rule. Employers may want to audit their employees to determine who is affected and make determinations on how to comply. This could include considering increasing the employees’ salary to satisfy the threshold, re-classifying employees to non-exempt, planning for payment of overtime, or limiting employees’ working hours to 40 or fewer per work week.

## **Non-Compete Agreements Banned**

On April 23, 2024, the Federal Trade Commission (the “FTC”) issued a new rule (the “Final Rule”) prohibiting employers from entering into and/or enforcing non-compete agreements in employment contracts. A non-compete agreement is defined broadly as any term or condition of employment that prohibits or penalizes an employee from (1) seeking or accepting employment with a different employer where such work would begin after the

conclusion of the employment, or (2) operating a business after the conclusion of the employment.

All employers that are within the FTC’s jurisdiction, regardless of size, are required to comply with the Final Rule. Consequently, the Final Rule applies to most for-profit entities but does not apply to non-profit entities. The prohibition on non-compete agreements applies to all workers, including employees, independent contractors, volunteers, and anyone else who works for a covered employer, whether paid or unpaid.

The Final Rule is expected to go into effect on September 4, 2024, although there have been multiple legal challenges that could affect its enforceability on that date. Not only does the Final Rule prohibit employers from entering into new non-compete agreements with employees on or after the effective date, but it also prohibits employers from enforcing existing non-compete agreements against employees. There are exceptions to the Final Rule’s prohibition on non-compete agreements, including for senior executives with existing non-compete agreements. Additionally, prior to this effective date, employers are required to notify employees that their existing non-compete agreements are no longer enforceable, no longer in effect, and will not be enforced.

The Final Rule is expected to have significant impact on employers across all professions. Moving forward, employers should seek assistance and guidance on restructuring employment agreements and adopting language to notify employees of the unenforceability of the non-compete agreements to comply with the Final Rule.

### **Pregnant Workers Fairness Act (PWFA) Regulations Released**

On April 15, 2024, the Equal Employment Opportunity Commission (“EEOC”) issued its final regulation relating to the Pregnant Workers Fairness Act (“PWFA”) that went into effect last year. The PWFA requires public and private sector employers with 15 or more employees to provide “reasonable accommodations” to pregnant employees related to their pregnancy, childbirth, or related medical conditions. The final regulations go into effect on June 18, 2024.

Under the rules, an employer must provide reasonable accommodations for an employee’s “known limitations” and cannot require an employee to accept an accommodation other than what is determined through the interactive process. Notably, under the final regulations, even if an employee is *temporarily* unable to perform one or more essential functions of their job, the employee is still qualified to perform their job, and the employer must engage in the interactive process to consider what reasonable accommodations can be made. Employers are not required to provide a reasonable accommodation if the accommodation would pose an undue hardship, meaning there would be significant difficulty or expense in providing the accommodation.

Employers will want to review their policies and practices to ensure they comply with the PWFA and the applicable regulation. It will be important for employers to ensure they have processes in place for employees to notify them of a “known limitation” and to evaluate if the employee is qualified even if they are temporarily unable to perform the essential functions of their position due to the employee’s pregnancy, childbirth, or related medical conditions.

If you would like assistance working through any of these issues, please feel free to contact Ahlers & Cooney for more information.

## Employment Law Attorneys



Katherine Beenken



Jennifer Clendenin



Jason Craig

515-246-0303

[Email Katherine](#)



515-246-0311

[Email Jennifer](#)



515-246-0372

[Email Jason](#)



Emily Ellingson

515-246-0361

[Email Emily](#)



Michael Galloway

515-246-0318

[Email Mike](#)



Danielle Haindfield

515-246-0374

[Email Danielle](#)



Elizabeth Heffernan

515-246-0356

[Email Elizabeth](#)



Aaron Hilligas

515-246-0327

[Email Aaron](#)



Kristy Latta

515-246-0323

[Email Kristy](#)





Samuel McMichael

515-246-0378

[Email Sam](#)



Brett Nitschke

515-246-0360

[Email Brett](#)



Nathan Overberg

515-246-0329

[Email Nathan](#)



Nicholas Pellegrin

515-246-0343

[Email Nick](#)



Jazmine Polk

515-246-0376

[Email Jazmine](#)



Rebecca Reif

515-246-0347

[Email Rebecca](#)



Ann Smisek

515-246-0310

[Email Ann](#)



Andrew Tice

515-246-0317

[Email Andrew](#)



Miriam Van Heukelem

515-246-0342

[Email Miriam](#)



Lindsay Vaught

515-246-0333

[Email Lindsay](#)



Carrie Weber

515-246-0315

[Email Carrie](#)

[Our Website](#)

[Client Alerts](#)

[Practice Areas](#)

[Attorneys](#)

## About Ahlers & Cooney's Client Alerts

Our Client Alerts are intended to provide occasional general comments on new developments in Federal and State law and regulations which we believe might be of interest to our clients. The Client Alerts should not be considered opinions of Ahlers & Cooney, P.C., and are not intended to provide legal advice as a substitute for seeking professional counsel. Readers should not under any circumstance act upon the information in this publication without seeking specific professional counsel. Ahlers & Cooney will be pleased to provide additional details regarding any article upon request. Additional copies of this Client Alert may be obtained by contacting any attorney in the Firm or by visiting the Firm's website at [www.ahlerslaw.com](http://www.ahlerslaw.com).

©2024 Ahlers & Cooney, P.C. All Rights Reserved.

**NOTICE TO THE PUBLIC** The determination of the need for legal services and the choice of a lawyer are extremely important decisions and should not be based solely upon advertisements or self-proclaimed expertise. This disclosure is required by rule of the Supreme Court of Iowa. Memberships and offices in legal fraternities and legal societies, technical and professional licenses, and memberships in scientific, technical and professional associations and societies of law or field of practice does not mean that a lawyer is a specialist or expert in a field of law, nor does it mean that such lawyer is necessarily any more expert or competent than any other lawyer. All potential clients are urged to make their own independent investigation and evaluation of any lawyer being considered. This notice is required by rule of the Supreme Court of Iowa.

**Ahlers & Cooney, P.C.**

Visit our website

Ahlers & Cooney, P.C. | 100 Court Avenue, Suite 600, Des Moines, IA 50309

[Unsubscribe bsandquist@adeliowa.org](mailto:bsandquist@adeliowa.org)

[Update Profile](#) | [Constant Contact Data Notice](#)

Sent by [info@ahlerslaw.com](mailto:info@ahlerslaw.com) powered by





**AGENDA ITEM NO. 6.g**  
**AGENDA SECTION: NEW**  
**BUSINESS**

## **ADEL CITY COUNCIL AGENDA ITEM REPORT**

**MEETING DATE:** July 9, 2024

**AGENDA HEADING:** Consider Approval of Resolution No. 24-44, Setting A Date for a Public Hearing on the Proposed Vacations of Right-of-Ways Along Bradfield Street Within Southbridge Plat 7 for 6:00 p.m. on Tuesday, August 13th, 2024

**ATTACHMENTS:**  
[Resolution No. 24-44, Setting Date of PH on Vacations of Southbridge Plat 7 ROWs.pdf](#)

**(This agenda item should be incorporated with the other items in your regular agenda and posted or published as required)**

AGENDA ITEM

Governmental Body: City of Adel, Iowa  
Date of Meeting: July 9, 2024  
Time of Meeting: 6:00 o'clock P.M.  
Place of Meeting: Council Chambers, 301 S. 10<sup>th</sup> Street, Adel, IA 50003

PUBLIC NOTICE IS HEREBY GIVEN that the above mentioned governmental body will meet at the date, time and place above set out. The tentative agenda for said meeting is as follows:

- Resolution fixing date for a public hearing on the proposed vacation of right-of-way along Bradfield Street within Southbridge Plat 7, an official plat in the City of Adel

Such additional matters as are set forth on the additional \_\_\_\_\_ pages(s) attached hereto.  
(number)

This notice is given at the direction of the Mayor pursuant to Chapter 21, Code of Iowa, and the local rules of said governmental body.

\_\_\_\_\_  
City Clerk, Adel, Iowa

July 9, 2024

The City Council of Adel, Iowa, met in \_\_\_\_\_ session, in the Council Chambers, 301 S. 10<sup>th</sup> Street, Adel, IA, at 6:00 o'clock P.M., on the above date. There were present Mayor \_\_\_\_\_, in the chair, and the following named Council Members:

\_\_\_\_\_  
\_\_\_\_\_

Absent: \_\_\_\_\_

\* \* \* \* \*

Council Member \_\_\_\_\_ introduced the following Resolution entitled "RESOLUTION FIXING DATE FOR A PUBLIC HEARING ON THE PROPOSED VACATION OF RIGHT-OF-WAY ALONG BRADFIELD STREET WITHIN SOUTHBRIDGE PLAT 7, AN OFFICIAL PLAT IN THE CITY OF ADEL", and moved its adoption. Council Member \_\_\_\_\_ seconded the motion to adopt. The roll was called and the vote was,

AYES: \_\_\_\_\_

\_\_\_\_\_

NAYS: \_\_\_\_\_

\_\_\_\_\_

Whereupon, the Mayor declared the Resolution duly adopted as follows:

**RESOLUTION NO. 24-44**

**RESOLUTION FIXING DATE FOR A PUBLIC HEARING ON THE PROPOSED VACATION OF RIGHT-OF-WAY ALONG BRADFIELD STREET WITHIN SOUTHBRIDGE PLAT 7, AN OFFICIAL PLAT IN THE CITY OF ADEL**

WHEREAS, Iowa Code section 354.23 requires that public ways within official plats be vacated after published notice and public hearing; and

WHEREAS, the City proposes to vacate right of way along Bradfield Street within Southbridge Plat 7, an official plat in the City of Adel described as follows:

A PART OF STREET LOT 'B', SOUTHBRIDGE PLAT 7, AN OFFICIAL PLAT IN THE CITY OF ADEL, DALLAS COUNTY, IOWA AND MORE PARTICULARLY DESCRIBED AS FOLLOWS:

COMMENCING AT THE SOUTHWEST CORNER OF SAID STREET LOT 'B'; THENCE NORTHEASTERLY ALONG THE SOUTHERLY LINE OF SAID STREET LOT 'B' AND A CURVE CONCAVE SOUTHEASTERLY WHOSE RADIUS IS 25.00 FEET, WHOSE ARC LENGTH IS 39.27 FEET AND WHOSE CHORD BEARS NORTH 45°05'12" EAST, 35.36 FEET; THENCE SOUTH 89°54'49" EAST ALONG SAID SOUTHERLY LINE, 77.50 FEET; THENCE NORTH 83°44'46" EAST ALONG SAID SOUTHERLY LINE, 45.28 FEET; THENCE SOUTH 89°54'49" EAST ALONG SAID SOUTHERLY LINE, 48.49 FEET TO THE POINT OF BEGINNING; THENCE SOUTH 89°54'49" EAST, 110.00 FEET; THENCE SOUTHWESTERLY ALONG SAID SOUTHERLY LINE AND A CURVE CONCAVE SOUTHEASTERLY WHOSE RADIUS IS 25.00 FEET, WHOSE ARC LENGTH IS 39.27 FEET AND WHOSE CHORD BEARS SOUTH 45°05'20" WEST, 35.35 FEET; THENCE NORTH 89°55'03" WEST ALONG SAID SOUTHERLY LINE, 60.00 FEET; THENCE NORTHWESTERLY ALONG SAID SOUTHERLY LINE AND A CURVE CONCAVE SOUTHWESTERLY WHOSE RADIUS IS 25.00 FEET, WHOSE ARC LENGTH IS 39.27 FEET AND WHOSE CHORD BEARS NORTH 44°54'40" WEST, 35.36 FEET TO THE POINT OF BEGINNING AND CONTAINING 0.04 ACRES (1,768 SQUARE FEET);

AND

A PART OF STREET LOT 'B', SOUTHBRIDGE PLAT 7, AN OFFICIAL PLAT IN THE CITY OF ADEL, DALLAS COUNTY, IOWA AND MORE PARTICULARLY DESCRIBED AS FOLLOWS:

COMMENCING AT THE EAST CORNER OF LOT 1, SAID SOUTHBRIDGE PLAT 7; THENCE SOUTH 60°03'04" WEST ALONG THE SOUTHERLY LINE

OF SAID LOT 1, A DISTANCE OF 388.01 FEET; THENCE SOUTHWESTERLY ALONG SAID SOUTHERLY LINE AND A CURVE CONCAVE NORTHWESTERLY WHOSE RADIUS IS 970.00 FEET, WHOSE ARC LENGTH IS 508.49 FEET AND WHOSE CHORD BEARS SOUTH 75°04'08" WEST, 502.68 FEET; THENCE SOUTH 05°54'12" EAST, 60.00 FEET TO THE SOUTHERLY LINE OF SAID STREET LOT 'B' AND THE POINT OF BEGINNING; THENCE SOUTHWESTERLY ALONG SAID SOUTHERLY LINE AND A CURVE CONCAVE SOUTHEASTERLY WHOSE RADIUS IS 25.00 FEET, WHOSE ARC LENGTH IS 36.65 FEET AND WHOSE CHORD BEARS SOUTH 42°05'38" WEST, 33.46 FEET; THENCE SOUTH 00°05'28" WEST ALONG SAID SOUTHERLY LINE, 5.77 FEET; THENCE NORTH 89°54'32" WEST ALONG SAID SOUTHERLY LINE, 60.00 FEET; THENCE NORTHWESTERLY ALONG SAID SOUTHERLY LINE AND A CURVE CONCAVE SOUTHWESTERLY WHOSE RADIUS IS 25.00 FEET, WHOSE ARC LENGTH IS 39.27 FEET AND WHOSE CHORD BEARS NORTH 44°54'49" WEST, 35.36 FEET; THENCE EASTERLY ALONG A CURVE CONCAVE NORTHERLY WHOSE RADIUS IS 1030.00 FEET, WHOSE ARC LENGTH IS 107.59 FEET AND WHOSE CHORD BEARS NORTH 87°05'21" EAST, 107.54 FEET TO THE POINT OF BEGINNING AND CONTAINING 0.04 ACRES (1,841 SQUARE FEET).

WHEREAS the City Council wishes to give proper consideration to such vacation as required by law:

NOW THEREFORE BE IT RESOLVED by the City Council of the City of Adel, Iowa that:

Section 1. That this Council meet in the Council Chambers, 301 S. 10<sup>th</sup> Street, Adel, Iowa, on August 13, 2024 at 6:00 p.m., for the purpose of taking action on the matter of the proposed vacation.

Section 2. That the City Clerk is hereby directed to cause at least one publication to be made of a notice of said meeting, in a legal newspaper, printed wholly in the English language, published at least once weekly, and having general circulation in said City, said publication to be not less than four (4) clear days nor more than twenty (20) days before the date of said public meeting.

Section 3. The notice of the proposed action shall be in substantially the following form:

**NOTICE OF PUBLIC HEARING ON THE PROPOSED VACATION OF  
RIGHT-OF-WAY ALONG BRADFIELD STREET WITHIN  
SOUTHBRIDGE PLAT 7, AN OFFICIAL PLAT IN THE CITY OF ADEL**

The City of Adel hereby gives notice that at the regular meeting of the City Council to be held at the Council Chambers, 301 S. 10<sup>th</sup> Street, Adel, Iowa on the 13th day of August, 2024 at

6:00 P.M., the City Council will hold a public hearing and consider whether to approve by ordinance the vacation of the following public property, to wit:

A PART OF STREET LOT 'B', SOUTHBRIDGE PLAT 7, AN OFFICIAL PLAT IN THE CITY OF ADEL, DALLAS COUNTY, IOWA AND MORE PARTICULARLY DESCRIBED AS FOLLOWS:

COMMENCING AT THE SOUTHWEST CORNER OF SAID STREET LOT 'B'; THENCE NORTHEASTERLY ALONG THE SOUTHERLY LINE OF SAID STREET LOT 'B' AND A CURVE CONCAVE SOUTHEASTERLY WHOSE RADIUS IS 25.00 FEET, WHOSE ARC LENGTH IS 39.27 FEET AND WHOSE CHORD BEARS NORTH 45°05'12" EAST, 35.36 FEET; THENCE SOUTH 89°54'49" EAST ALONG SAID SOUTHERLY LINE, 77.50 FEET; THENCE NORTH 83°44'46" EAST ALONG SAID SOUTHERLY LINE, 45.28 FEET; THENCE SOUTH 89°54'49" EAST ALONG SAID SOUTHERLY LINE, 48.49 FEET TO THE POINT OF BEGINNING; THENCE SOUTH 89°54'49" EAST, 110.00 FEET; THENCE SOUTHWESTERLY ALONG SAID SOUTHERLY LINE AND A CURVE CONCAVE SOUTHEASTERLY WHOSE RADIUS IS 25.00 FEET, WHOSE ARC LENGTH IS 39.27 FEET AND WHOSE CHORD BEARS SOUTH 45°05'20" WEST, 35.35 FEET; THENCE NORTH 89°55'03" WEST ALONG SAID SOUTHERLY LINE, 60.00 FEET; THENCE NORTHWESTERLY ALONG SAID SOUTHERLY LINE AND A CURVE CONCAVE SOUTHWESTERLY WHOSE RADIUS IS 25.00 FEET, WHOSE ARC LENGTH IS 39.27 FEET AND WHOSE CHORD BEARS NORTH 44°54'40" WEST, 35.36 FEET TO THE POINT OF BEGINNING AND CONTAINING 0.04 ACRES (1,768 SQUARE FEET);

AND

A PART OF STREET LOT 'B', SOUTHBRIDGE PLAT 7, AN OFFICIAL PLAT IN THE CITY OF ADEL, DALLAS COUNTY, IOWA AND MORE PARTICULARLY DESCRIBED AS FOLLOWS:

COMMENCING AT THE EAST CORNER OF LOT 1, SAID SOUTHBRIDGE PLAT 7; THENCE SOUTH 60°03'04" WEST ALONG THE SOUTHERLY LINE OF SAID LOT 1, A DISTANCE OF 388.01 FEET; THENCE SOUTHWESTERLY ALONG SAID SOUTHERLY LINE AND A CURVE CONCAVE NORTHWESTERLY WHOSE RADIUS IS 970.00 FEET, WHOSE ARC LENGTH IS 508.49 FEET AND WHOSE CHORD BEARS SOUTH 75°04'08" WEST, 502.68 FEET; THENCE SOUTH 05°54'12" EAST, 60.00 FEET TO THE SOUTHERLY LINE OF SAID STREET LOT 'B' AND THE POINT OF BEGINNING; THENCE SOUTHWESTERLY ALONG SAID SOUTHERLY LINE AND A CURVE CONCAVE SOUTHEASTERLY WHOSE RADIUS IS 25.00 FEET, WHOSE ARC LENGTH IS 36.65 FEET AND WHOSE CHORD BEARS SOUTH 42°05'38" WEST, 33.46 FEET; THENCE SOUTH 00°05'28"

WEST ALONG SAID SOUTHERLY LINE, 5.77 FEET; THENCE NORTH 89°54'32" WEST ALONG SAID SOUTHERLY LINE, 60.00 FEET; THENCE NORTHWESTERLY ALONG SAID SOUTHERLY LINE AND A CURVE CONCAVE SOUTHWESTERLY WHOSE RADIUS IS 25.00 FEET, WHOSE ARC LENGTH IS 39.27 FEET AND WHOSE CHORD BEARS NORTH 44°54'49" WEST, 35.36 FEET; THENCE EASTERLY ALONG A CURVE CONCAVE NORTHERLY WHOSE RADIUS IS 1030.00 FEET, WHOSE ARC LENGTH IS 107.59 FEET AND WHOSE CHORD BEARS NORTH 87°05'21" EAST, 107.54 FEET TO THE POINT OF BEGINNING AND CONTAINING 0.04 ACRES (1,841 SQUARE FEET).

At the above meeting the Council shall receive oral or written objections from any resident or property owner of said City to the proposal to vacate the public right-of-way. After all objections have been received and considered, the Council will at this meeting or at any adjournment thereof, take additional action on the proposal or will abandon the proposal to vacate the public property.

This Notice is given by authority of the City Council of the City of Adel.

Dated this \_\_\_\_\_ day of \_\_\_\_\_, 2024.

\_\_\_\_\_  
City Clerk, City of Adel, Iowa

(End of Notice)

Dated this 9<sup>th</sup> day of July, 2024.

---

Mayor

Attest:

---

City Clerk

