

BAL HARBOUR

- V I L L A G E -

Mayor Jeffrey P. Freimark
Vice Mayor Seth E. Salver
Councilman Alejandro Levy
Councilman Buzzy Sklar
Councilman David Wolf

Village Manager Jorge M. Gonzalez
Village Clerk Dwight S. Danie
Village Attorneys Weiss Serota
Helfman Cole & Bierman, P.L.

Bal Harbour Village Council

Regular Meeting Agenda

November 19, 2024

At 6:30 PM

Bal Harbour Village Hall • Council Chamber • 655 96th Street • Bal Harbour • Florida 33154

This meeting will be conducted in person. The meeting will also be broadcast on our website at <https://balharbourfl.gov/government/village-clerk/minutes-and-agendas/>. Members of the public are also encouraged to participate by email (meetings@balharbourfl.gov) or by telephone at 305-865-6449.

*BHV Who We Are, Vision, Mission, Values / The Bal Harbour Experience
[The Bal Harbour Experience.pdf](#)*

CALL TO ORDER/ PLEDGE OF ALLEGIANCE

REQUESTS FOR ADDITIONS, WITHDRAWALS AND DEFERRALS

PRESENTATIONS AND AWARDS

- PA1** Veterans Day Recognition - Elias Sussman
- PA2** Alzheimer's Awareness Month - Proclamation
- PA3** Florida Department Of Transportation (FDOT) - Presentation

CONSENT AGENDA

C6 - COUNCIL MINUTES

- C6A** Approval of Minutes
[VillageCouncil-RegularCouncilWorkshopMinutes_October29_2024.pdf](#)
[VillageCouncil-RegularCouncilMeetingMinutes_October29_2024.pdf](#)

C7 - CONSENT AGENDA RESOLUTIONS

- C7A** Accepting Liquor License Toscana Divino LLC - 10275 Collins Avenue
A RESOLUTION OF THE VILLAGE COUNCIL OF BAL HARBOUR VILLAGE, FLORIDA; ACCEPTING THE DETERMINATION OF THE VILLAGE BUILDING OFFICIAL THAT TOSCANA DIVINO LLC, DBA TOSCANINO HARBOUR HOUSE APPLICATION TO THE STATE OF FLORIDA DEPARTMENT OF ALCOHOLIC

BEVERAGES AND TOBACCO FOR THE RESTAURANT'S 2COP LICENSE THAT IS LOCATED INSIDE THE HARBOUR HOUSE CONDOMINIUM RESTAURANT IS COMPATIBLE WITH VILLAGE ZONING REGULATIONS; PROVIDING FOR IMPLEMENTATION; PROVIDING FOR AN EFFECTIVE DATE.

[Item Summary - Toscanino Harbour House Liquor License ADA.pdf](#)

[Memorandum - Toscanino Harbour House Liquor License ADA.pdf](#)

[Resolution - Toscanino Harbour House Liquor License ADA.pdf](#)

[Attachment - Toscanino Harbour House DBPR ABT-6001 ADA.pdf](#)

[Attachment - Toscanino Harbour House Condo Letter ADA.pdf](#)

- C7B** Approving The Purchase Of Vertical Mast Light Towers - Kelly Tractor Company
A RESOLUTION OF THE VILLAGE COUNCIL OF BAL HARBOUR VILLAGE, FLORIDA; APPROVING THE PURCHASE OF THREE WACKER NEUSON VERTICAL MAST LIGHT TOWERS, MODEL NO. LTV6L, FROM KELLY TRACTOR COMPANY FOR THE VILLAGE, IN THE AMOUNT NOT TO EXCEED FORTY-ONE THOUSAND NINE HUNDRED TWENTY-FIVE DOLLARS (\$41,925); PROVIDING FOR IMPLEMENTATION; PROVIDING FOR AN EFFECTIVE DATE.

[Item Summary - Purchase Of Vertical Mast Light Towers ADA.pdf](#)

[Memorandum - Purchase Of Vertical Mast Light Towers ADA.pdf](#)

[Resolution - Purchase Of Vertical Mast Light Towers ADA.pdf](#)

[Attachment - Wacker Neuson - Quote for Light Tower ADA.pdf](#)

R5 - ORDINANCES

- R5A** Ordinance - Regulating Public Camping & Sleeping (First Reading)
AN ORDINANCE OF THE VILLAGE COUNCIL OF BAL HARBOUR VILLAGE, FLORIDA, AMENDING CHAPTER 12 "OFFENSES" OF THE CODE OF ORDINANCES TO CREATE SECTION 12-11 "PUBLIC CAMPING OR SLEEPING" TO ESTABLISH DEFINITIONS AND REGULATIONS; PROVIDING FOR CONFLICTS; PROVIDING FOR SEVERABILITY; PROVIDING FOR INCLUSION IN THE CODE; AND PROVIDING FOR AN EFFECTIVE DATE.

[Item Summary - Public Camping and Sleeping ADA.pdf](#)

[Memorandum - Public Camping and Sleeping ADA.pdf](#)

[Ordinance - Public Camping or Sleeping ADA.pdf](#)

R7 - RESOLUTIONS

- R7A** Approving BHCA Legal Representation Related To FPL Electrical Reliability
A RESOLUTION OF THE VILLAGE COUNCIL OF BAL HARBOUR VILLAGE, FLORIDA; APPROVING THE EXPENDITURE OF LANDSCAPE AND SECURITY ASSESSMENT FUNDS FOR CERTAIN LEGAL EXPENDITURES IN THE ASSESSMENT DISTRICT IN AN AMOUNT NOT TO EXCEED FIFTY THOUSAND (\$50,000) DOLLARS; PROVIDING FOR IMPLEMENTATION; PROVIDING FOR AN EFFECTIVE DATE.

[Item Summary - BHCA Legal Representation ADA.pdf](#)

[Memorandum - BHCA Legal Representation ADA.pdf](#)

[Resolution - BHCA Legal Representation ADA.pdf](#)

[Attachment - GBW Engagement Letter ADA.pdf](#)

R7B Approving Fiscal Year 2024 Operating & Capital Budget Amendment
A RESOLUTION OF THE VILLAGE COUNCIL OF BAL HARBOUR VILLAGE, FLORIDA; AMENDING THE FY 2024 BUDGET BY REVISING THE 2024 FISCAL YEAR OPERATING AND CAPITAL BUDGET AS OUTLINED IN EXHIBIT "A" ATTACHED HERETO; AUTHORIZING THE VILLAGE MANAGER TO DO ALL THINGS NECESSARY TO CARRY OUT THE AIMS OF THIS RESOLUTION; AND PROVIDING FOR AN EFFECTIVE DATE.

[Item Summary - Year End Budget Amendment for FY 2024 ADA.pdf](#)

[Memorandum - Year End Budget Amendment for FY 2024 ADA.pdf](#)

[Resolution - Year End Budget Amendment for FY 2024 ADA.pdf](#)

[Attachment - Exhibit A - FY 2024 Revenues and Expenditures Summary Amendment ADA.pdf](#)

R7C Approving Rivage Condominium Voluntary Contribution Agreement With Carlton Terrace Owner, LLC - \$3 Million

A RESOLUTION OF THE VILLAGE COUNCIL OF BAL HARBOUR VILLAGE, FLORIDA; APPROVING THE VOLUNTARY CONTRIBUTION AGREEMENT REGARDING RIVAGE WITH CARLTON TERRACE OWNER, LLC; PROVIDING FOR IMPLEMENTATION; PROVIDING FOR AN EFFECTIVE DATE.

[Item Summary - Rivage Condominium Voluntary Contribution Agreement ADA.pdf](#)

[Memorandum - Rivage Condominium Voluntary Contribution Agreement ADA.pdf](#)

[Resolution - Rivage Condominium Voluntary Contribution Agreement ADA.pdf](#)

[Attachment - Voluntary Contribution Agreement executed by Rivage ADA.pdf](#)

R7D Ratifying Grant Agreement With Florida Inland Navigation District (FIND) For The Harbourfront Park Project - \$3 Million

A RESOLUTION OF THE VILLAGE COUNCIL OF BAL HARBOUR VILLAGE, FLORIDA, RATIFYING THE EXECUTION OF THE GRANT AGREEMENT WITH THE FLORIDA INLAND NAVIGATION DISTRICT (FIND) FOR THE HARBOURFRONT PARK PHASE III STRUCTURAL PROJECT (SEGMENT B) IN THE AMOUNT OF THREE MILLION DOLLARS (\$3,000,000); AUTHORIZING THE VILLAGE MANAGER TO IMPLEMENT THE TERMS AND CONDITIONS OF THE AGREEMENT; PROVIDING FOR IMPLEMENTATION; PROVIDING FOR AN EFFECTIVE DATE.

[Item Summary - Harbourfront Park Phase III FIND Grant Agreement ADA.pdf](#)

[Memorandum - Harbourfront Park Phase III FIND Grant Agreement ADA.pdf](#)

[Resolution - Harbourfront Park Phase III FIND Grant Agreement ADA.pdf](#)

[Attachment - Exhibit A - DA-BHV-24-293 Village Jetty and Cutwalk Segment B Agreement Signed ADA.pdf](#)

R7E Approving Additional Services For The Harbourfront Park Project - Moffatt & Nichol

A RESOLUTION OF THE VILLAGE COUNCIL OF BAL HARBOUR VILLAGE, FLORIDA; APPROVING ADDITIONAL SERVICES TO THE PROFESSIONAL SERVICES AGREEMENT WITH CHARLES H. BENSON & ASSOCIATES ARCHITECTS FOR THE PROVISION OF ADDITIONAL STRUCTURAL ENGINEERING SERVICES WITH MOFFATT & NICHOL, IN AN AMOUNT NOT TO EXCEED ONE HUNDRED SEVENTY-SEVEN THOUSAND EIGHT HUNDRED DOLLARS (\$177,800); PROVIDING FOR IMPLEMENTATION; PROVIDING FOR AN EFFECTIVE DATE.

[Item Summary - Additional Services For Harbourfront Park Project - Moffatt & Nichol ADA.pdf](#)

[Memorandum - Additional Services For Harbourfront Park Project - Moffatt & Nichol ADA.pdf](#)
[Resolution - Additional Services For Harbourfront Park Project - Moffatt & Nichol ADA.pdf](#)
[Attachment - Exhibit A - Moffatt & Nichol - Additional Services Fee Proposal ADA.pdf](#)

R7F Authorizing Bal Harbour Village To Act As Fiscal Agent and The Village Manager To Execute Addendums Related To The Harbourfront Park Project

A RESOLUTION OF THE VILLAGE COUNCIL OF BAL HARBOUR VILLAGE, FLORIDA, AUTHORIZING BAL HARBOUR VILLAGE TO ACT AS THE FISCAL AGENT FOR ALL SUBCONSULTANT ARCHITECTURE AND ENGINEERING AGREEMENTS ASSOCIATED WITH THE HARBOURFRONT PARK, JETTY, AND CUTWALK PROJECT; AUTHORIZING THE VILLAGE MANAGER TO EXECUTE ADDENDUMS AS FISCAL AGENT TO THE SUBCONSULTANT CONTRACTS FOR SERVICES AS REQUIRED BY CHARLES H. BENSON & ASSOCIATES, ARCHITECTS, P.A., FOLLOWING THE ASSIGNMENT OF SERVICES FROM MIKYOUNG KIM DESIGN; PROVIDING FOR IMPLEMENTATION; AND PROVIDING FOR AN EFFECTIVE DATE.

[Item Summary - Village Fiscal Agent for Subconsultants Harbourfront Park Project ADA.pdf](#)
[Memorandum - Village Fiscal Agent for Subconsultants Harbourfront Park Project ADA.pdf](#)
[Resolution - Village Fiscal Agent for Subconsultants Harbourfront Park Project ADA.pdf](#)
[Attachment - Assignment of Agreement - Charles Benson and Associates Executed ADA.pdf](#)
[Attachment - Exhibit A - Addendum to Subconsultant Contract for Services ADA.pdf](#)

R9 - NEW BUSINESS AND COUNCIL DISCUSSION

R9A Discussion Regarding Upcoming Meeting Dates - Jorge M. Gonzalez, Village Manager

[Upcoming Meeting Dates - Jorge M. Gonzalez, Village Manager ADA.pdf](#)

R9B - PUBLIC COMMENT

R10 - VILLAGE MANAGER REPORT

R11 - VILLAGE CLERK REPORT

Lobbyist Report

[R11A1_Lobbyist Registration Report as of November13_2024.pdf](#)

R12 - VILLAGE ATTORNEY REPORT

R12A Monthly Attorney Report

[October - Monthly Attorney Report ADA.pdf](#)

END OF REGULAR AGENDA

ADJOURNMENT

One or more members of any Village Committee/Board may attend this meeting of the Council and may discuss matters which may later come before their respective Boards/Committees. The New Business and Council Discussion Section includes a section

for Public Comment. On public comment matters, any person is entitled to be heard by this Council on any matter; however, no action shall be taken by the Council on a matter of public comment, unless the item is specifically listed on the agenda, or is added to the agenda by Council action.

Any person who acts as a lobbyist, pursuant to Village Code Section 2-301 (Lobbyists), must register with the Village Clerk, prior to engaging in lobbying activities before Village staff, boards, committees, and/or the Village Council. A copy of the Ordinance is available in the Village Clerk's Office at Village Hall. If a person decides to appeal any decision made by the Village Council with respect to any matter considered at a meeting or hearing, that person will need a record of the proceedings and, for such purpose, may need to ensure that a verbatim record of the proceedings is made, which record includes the testimony and evidence upon which the appeal is to be based (F.S. 286.0105).

All persons who need assistance or special accommodations to participate in virtual meetings please contact the Village Clerk's Office (305-866-4633), not later than two business days prior to such proceeding. In accordance with the Americans with Disabilities Act of 1990, all persons who are disabled and who need special accommodations to participate in this proceeding because of that disability should contact the Village Clerk's Office (305-866-4633), not later than two business days prior to such proceeding.

All Village Council meeting attendees, including Village staff and consultants, are subject to security screening utilizing a metal detector and/or wand, prior to entering the Council Chamber, Conference Room, or other meeting area located within Village Hall. This is for the safety of everyone. Thanks for your cooperation.

BAL HARBOUR

- V I L L A G E -

Mayor Jeffrey P. Freimark
Vice Mayor Seth E. Salver
Councilman David J. Albaum
Councilman Buzzy Sklar
Councilman David Wolf

Village Manager Jorge M. Gonzalez
Village Clerk Dwight S. Danie
Village Attorneys Weiss Serota
Helfman Cole & Bierman, P.L.

Bal Harbour Village Council

Workshop Minutes

October 29, 2024

At 5:30 PM

Bal Harbour Village Hall • Council Chamber • 655 96th Street • Bal Harbour • Florida 33154

Mayor Freimark called the meeting to order at 5:39 P.M.

The following were present:

Mayor Jeffrey P. Freimark
Vice Mayor Seth E. Salver
Councilman David Wolf (via Zoom)
Councilman Buzzy Sklar
Councilman David J. Albaum

Also present:

Jorge M. Gonzalez, Village Manager
Dwight S. Danie, Village Clerk
Susan Trevarthen, Village Attorney
Dolores Mejia
Alejandro Levy
Dave Sanchez

Mayor Freimark opened the conversation regarding the election of the Mayor and Vice Mayor that will occur at the November 18, 2024 Induction Meeting.

He stated that, despite agreeing to step down as Mayor after his present term, the past two years had shifted his perspective due to the existential threat posed by litigation with the Bal Harbour Shops. Having engaged in high-level talks with Shops representatives and State officials, he said that he believed leadership continuity was necessary. He proposed that he and Vice Mayor Salver serve one more year as Mayor and Vice Mayor respectively with Vice Mayor Salver succeeding him thereafter.

Vice Mayor Salver expressed his continued interest in serving as mayor, highlighting his deep connection to the community where he was raised, and has raised his family. He acknowledged the seriousness of the ongoing issues with the Shops, adding that he would be willing to wait an additional year. He asked that he be allowed a full two-year term afterwards.

Councilman Albaum said that he was in favor of the proposal.

Councilman Sklar said he recollected that Mayor Freimark had agreed that he would serve two years and then hand over the role to Vice Mayor Salver. He said that the title of “Mayor” might not be necessary to continue negotiations effectively, and that he believed that Mayor Freimark’s strength as a leader could allow him to represent the Council effectively, regardless of his title.

Mayor Freimark explained that the mayoral title carried significant weight in discussions with State representatives and principals from the Shops. He stated that he would only negotiate while serving as Mayor, as doing so without the title could undermine the rapport the Village had built with these parties. He emphasized that maintaining this rapport was critical for future settlements and Council discussions.

Councilman Wolf said that he was in support of the proposal if everyone agreed, adding that a one-year timeframe would be appropriate to observe any changes in the ongoing litigation or negotiation processes.

Mr. Gonzalez said he believed that any court resolution was unlikely within a 12-month window and that he foresaw appeals and a protracted process, adding that a settlement might emerge sooner with court-ordered mediation.

Councilman Sklar said that these projections were speculative and questioned whether a smooth transition would be feasible if mid-negotiations were still unresolved after a year, and asked Mayor Freimark if he would step aside in a year despite significant ongoing discussions.

Councilman Wolf questioned whether altering the typical mayoral rotation would impact future procedures and asked the Village Attorney for a legal perspective, to which Ms. Trevarthen said that the proposal was legally sound, given that it wouldn’t extend beyond the current Council’s term.

Councilman Wolf then agreed with the proposal and he suggested the need to discuss and decide on the succession of Vice Mayor.

Councilman Sklar, said that he was a long-standing Council member with a strong community service record and dedication to the Village. He spoke about his deep involvement over the years as a Council member, trustee, and active participant in environmental initiatives, beach cleanups, and other community efforts.

Councilman Wolf proffered that tenure should not determine leadership roles. He highlighted his community involvement, including years on the Civic Association and other committees, while noting his fresh perspective and collaborative approach. He described his availability to serve fully in the Vice Mayor role, and said he saw it as preparation for future leadership.

After a general discussion, there was consensus from those attending that they were in agreement with Mayor Freimark’s proposal to elected him as Mayor for one additional year, and Vice Mayor Salver as Vice Mayor for one additional year, after which Vice Mayor Salver would become Mayor and David Wolf would become Vice Mayor.

ADJOURNMENT - The meeting was adjourned at 6:23 PM.

Mayor Jeffrey Freimark



Attest:

Dwight S. Danie, Village Clerk

BAL HARBOUR

- V I L L A G E -

Mayor Jeffrey P. Freimark
Vice Mayor Seth E. Salver
Councilman David J. Albaum
Councilman Buzzy Sklar
Councilman David Wolf

Village Manager Jorge M. Gonzalez
Village Clerk Dwight S. Danie
Village Attorneys Weiss Serota
Helfman Cole & Bierman, P.L.

Bal Harbour Village Council

Regular Meeting Minutes

October 29, 2024

At 6:30 PM

Bal Harbour Village Hall • Council Chamber • 655 96th Street • Bal Harbour • Florida 33154

This meeting was conducted in person. The meeting was also broadcast on our website at <https://balharbourfl.gov/government/village-clerk/minutes-and-agendas/>. Members of the public were also encouraged to participate by email (meetings@balharbourfl.gov) or by telephone at 305-865-6449.

CALL TO ORDER/ PLEDGE OF ALLEGIANCE- Mayor Freimark called the meeting to order at 6:33 P.M.

The following were present:

Mayor Jeffrey P. Freimark
Vice Mayor Seth E. Salver
Councilman David Wolf via Zoom
Councilman Buzzy Sklar
Councilman David J. Albaum

Also present:

Jorge M. Gonzalez, Village Manager
Dwight S. Danie, Village Clerk
Susan Trevarthen, Village Attorney

The Pledge of Allegiance was led by Mayor Freimark.

Mayor Freimark expressed appreciation for Sergeant Chris Destefano and Officer Shevin Castro of the Bal Harbor Police Department, who had recently returned from providing aid in Longboat Key after Hurricane Milton.

REQUESTS FOR ADDITIONS, WITHDRAWALS AND DEFERRALS

There were no requests.

PRESENTATIONS AND AWARDS

PA1 Breast Cancer Awareness Month - Proclamation

The Mayor proclaimed October 2024 as Breast Cancer Awareness Month, emphasizing the significance of early detection, support for affected individuals, and honoring

healthcare workers and advocates in the ongoing fight against breast cancer. He encouraged the community to participate in related events and initiatives.

CONSENT AGENDA

C6 - COUNCIL MINUTES

C6A Approval of Minutes

C7 - RESOLUTIONS

C7A A RESOLUTION OF THE VILLAGE COUNCIL OF BAL HARBOUR VILLAGE, FLORIDA; APPROVING THE TASK AGREEMENT WITH CUMMINS CEDERBERG, INC., FOR THE PROVISION OF ENVIRONMENTAL CONSULTING SERVICES RELATED TO THE PLANNED FLOOD CONTROL AND COASTAL EMERGENCIES (FCCE) PROJECT TO PROVIDE BEACH NOURISHMENT AT BAL HARBOUR BEACH, AS SPECIFIED WITHIN CUMMINS CEDERBERG PROPOSAL NO. 77818, IN THE AMOUNT NOT TO EXCEED TWENTY EIGHT THOUSAND FIFTY DOLLARS (\$28,050), INCLUSIVE OF A TEN PERCENT (10%) CONTINGENCY ALLOCATION IN THE AMOUNT OF TWO THOUSAND FIVE HUNDRED FIFTY DOLLARS (\$2,550); PROVIDING FOR IMPLEMENTATION; PROVIDING FOR AN EFFECTIVE DATE.

C7B A RESOLUTION OF THE VILLAGE COUNCIL OF BAL HARBOUR VILLAGE, FLORIDA; APPROVING A MEMORANDUM OF UNDERSTANDING BETWEEN BAL HARBOUR VILLAGE, THE TOWN OF SURFSIDE, AND THE TOWN OF BAY HARBOR ISLAND TO FUND A POLICE SCHOOL RESOURCE OFFICER AT RUTH K. BROAD K-8 CENTER, AT AN ANNUAL COST NOT TO EXCEED TWENTY-ONE THOUSAND SIX HUNDRED FORTY-TWO DOLLARS AND THIRTY-THREE CENTS (\$21,642.33); PROVIDING FOR IMPLEMENTATION, PROVIDING FOR AN EFFECTIVE DATE.

C7C A RESOLUTION OF THE VILLAGE COUNCIL OF BAL HARBOUR VILLAGE, FLORIDA; AUTHORIZING AND APPROVING THE DONATION OF \$5,000.00 OF LAW ENFORCEMENT TRUST FUNDS TO THE ROTARY CLUB OF BAL HARBOUR; AUTHORIZING AND APPROVING THE DONATION OF \$2,500.00 OF LAW ENFORCEMENT TRUST FUNDS TO "DO THE RIGHT THING OF MIAMI, INC."; AUTHORIZING AND APPROVING THE DONATION OF \$2,500.00 OF LAW ENFORCEMENT TRUST FUNDS TO FATHERS M.I.A, INC; PROVIDING FOR IMPLEMENTATION; AND PROVIDING AN FOR EFFECTIVE DATE.

- C7D** A RESOLUTION OF THE VILLAGE COUNCIL OF BAL HARBOUR VILLAGE, FLORIDA; RATIFYING THE VILLAGE MANAGER'S DECLARATION AND TERMINATION OF A STATE OF EMERGENCY DUE TO HURRICANE MILTON; RATIFYING THE VILLAGE MANAGER'S ACTIONS TAKEN PURSUANT TO HIS POWERS UNDER THE VILLAGE STATE OF EMERGENCY FOR HURRICANE MILTON; PROVIDING FOR AN EFFECTIVE DATE.
- C7E** A RESOLUTION OF THE VILLAGE COUNCIL OF BAL HARBOUR VILLAGE, FLORIDA; AUTHORIZING THE VILLAGE MANAGER TO EXECUTE A NEW USE AND OCCUPANCY AGREEMENT BETWEEN BAL HARBOUR VILLAGE AND THE FLORIDA DEPARTMENT OF TRANSPORTATION (FDOT) FOR THE LEASE OF PARCEL 3120 UNDER THE BAKER'S HAULOVER BRIDGE; APPROVING THE INCORPORATED ADDENDUM; PROVIDING FOR IMPLEMENTATION; AND PROVIDING FOR AN EFFECTIVE DATE.
- C7F1** A RESOLUTION APPROVING AN AGREEMENT WITH ANDREINA RON PEDRIQUE FOR THE CREATION AND INSTALLATION OF THE PROPOSED TEMPORARY ART EXHIBIT AT THE 102nd STREET BEACH ACCESS PATH IN BAL HARBOUR VILLAGE; PROVIDING FOR IMPLEMENTATION; PROVIDING FOR AN EFFECTIVE DATE.
- C7F2** A RESOLUTION APPROVING AN AGREEMENT WITH FEDIDA FINE ART LLC. FOR THE CREATION AND INSTALLATION OF A TEMPORARY ART EXHIBIT AT THE BAL HARBOUR WATERFRONT PARK IN BAL HARBOUR VILLAGE; PROVIDING FOR IMPLEMENTATION; PROVIDING FOR AN EFFECTIVE DATE.
- C7G** A RESOLUTION OF THE VILLAGE COUNCIL OF BAL HARBOUR VILLAGE, FLORIDA; APPROVING A ONE-YEAR AGREEMENT WITH LIGHT ER UP LLC FOR THE PROVISION OF HOLIDAY DÉCOR AND LIGHTING DISPLAYS AT THE BAL HARBOUR WATERFRONT PARK IN AN AMOUNT NOT TO EXCEED TWENTY-FIVE THOUSAND (\$25,000) DOLLARS; PROVIDING FOR IMPLEMENTATION; PROVIDING FOR AN EFFECTIVE DATE.

MOTION: A Motion to approve the Consent Agenda was moved by Vice Mayor Seth E. Salver and seconded by Councilman Buzzy Sklar

VOTE: The Motion passed by unanimous voice vote (5-0).

R5 - ORDINANCES

- R5A** AN ORDINANCE OF THE VILLAGE COUNCIL OF BAL HARBOUR VILLAGE, FLORIDA, AMENDING CHAPTER 21 "ZONING" OF THE CODE OF ORDINANCES TO CLARIFY AND REVISE DEFINITIONS AND REGULATIONS APPLICABLE TO THE RESIDENTIAL ZONING DISTRICTS, AND TO PROVIDE REGULATORY INCENTIVES FOR AFFORDABLE RENTAL DWELLINGS; PROVIDING FOR CONFLICTS, SEVERABILITY, INCLUSION IN THE CODE, AND FOR AN EFFECTIVE DATE.

Mr. Gonzalez introduced the item saying that the ordinance focused on zoning changes aimed at fair housing incentives within specific residential districts. He said that the Local Planning Agency had recommended that the Village Council approve this ordinance. He added that this creates incentives for parcels that may not be eligible for Live Local treatment on the Ocean Front and RM5 districts.

Neca Logan, 64 Camden Drive, expressed her concern about zoning changes impacting gated communities and reducing parking, arguing that these changes might not serve the Village well. She suggested that the words "household staff" be used to replace "worker".

Ms. Trevarthen said that the term "servants" in the Code had been replaced with "workers" to align with modern language, while the term "accessory quarters" replaced "servants' quarters," adding that the adjustments aimed to be more inclusive, with no substantial impact on single-family zoning behind the gate.

MOTION: A motion to approve the ordinance on second reading was moved by Vice Mayor Seth E. Salver and seconded by Councilman Buzzy Sklar.

ROLL CALL	VOTE
Mayor Jeffrey P. Freimark	Yes
Vice Mayor Seth E. Salver	Yes
Councilman David J. Albaum	Yes
Councilman Buzzy Sklar	Yes
Councilman David Wolf	Yes

VOTE: The Motion passed by unanimous roll call vote (5-0).

- R5B** AN ORDINANCE OF THE VILLAGE COUNCIL OF BAL HARBOUR VILLAGE, FLORIDA, AMENDING CHAPTER 21 "ZONING" OF THE CODE OF ORDINANCES TO ESTABLISH DEFINITIONS AND REGULATIONS APPLICABLE TO MARIJUANA USES; PROVIDING FOR CONFLICTS, SEVERABILITY, INCLUSION IN THE CODE, AND FOR AN EFFECTIVE DATE.

Mr. Gonzalez introduced the item saying that the ordinance addressed a Statewide referendum on the use of recreational marijuana. He explained that State law currently mandates two zoning options for marijuana dispensaries: either ban them outright or regulate them similarly to pharmacies and that the Council had previously decided to pursue a ban rather than treating dispensaries like pharmacies within the business district.

Vice Mayor Salver expressed his appreciation for the forethought in addressing this issue before potential statewide legalization.

MOTION: A motion to approve the ordinance on second reading was moved by Councilman David Albaum and seconded by Vice Mayor Seth E. Salver.

ROLL CALL	VOTE
Mayor Jeffrey P. Freimark	Yes
Vice Mayor Seth E. Salver	Yes
Councilman David J. Albaum	Yes
Councilman Buzzy Sklar	Yes
Councilman David Wolf	Yes

VOTE: The Motion passed by unanimous roll call vote (5-0).

R7 - RESOLUTIONS

- R7A** A RESOLUTION OF THE VILLAGE COUNCIL OF BAL HARBOUR VILLAGE, FLORIDA; AUTHORIZING THE VILLAGE MANAGER TO NEGOTIATE AN AGREEMENT WITH THE FIRST RANKED FIRM, PERKINS & WILL ARCHITECT, INC. FOR THE PROVISION OF ARCHITECTURAL, ENGINEERING AND CONSTRUCTION ADMINISTRATION SERVICES FOR THE CONSTRUCTION OF THE BAL HARBOUR VILLAGE HALL; IN THE EVENT AN AGREEMENT CANNOT BE REACHED WITH THE FIRST RANKED FIRM, AUTHORIZING THE VILLAGE MANAGER TO NEGOTIATE AN AGREEMENT WITH THE SECOND RANKED FIRM WJ ARCHITECTS IN COLLABORATION WITH WOLFBERG ALVAREZ & PARTNERS; IN THE EVENT AN AGREEMENT CANNOT BE REACHED WITH THE SECOND RANKED FIRM, AUTHORIZING THE VILLAGE MANAGER TO NEGOTIATE AN AGREEMENT WITH THE THIRD RANKED FIRM MC HARRY ARCHITECTS IN COLLABORATION WITH ZAS ARCHITECTS; PROVIDING FOR IMPLEMENTATION; PROVIDING FOR AN EFFECTIVE DATE.

Mr. Gonzalez introduced the item describing the procedural requirements under state law for selecting architectural firms, which mandate issuing a Request for Qualifications (RFQ) and following Florida’s CCNA (Consultants' Competitive Negotiation Act) process. He said the evaluation committee had already pre-ranked the firms based on qualifications and project understanding, not on cost or specific design proposals. He said that each firm

would have 10 minutes to present their qualifications, followed by questions from the Council.

PERKINS & WILL ARCHITECT, INC.

Jose Gelabert-Navia, Perkins & Will, introduced himself and his team, Angel Suarez, Larry Kline, and Carlos Chiu describing their Miami office's 27 years of local expertise and the firm's "living design" philosophy, which he said integrates beauty, resilience, and well-being. They described their interdisciplinary approach, combining architecture, interior design, and landscape planning for cohesive, contextually sensitive projects. They then highlighted their portfolio including the Miami Beach City Hall Annex and the resilient Power & Light corporate center. Mr. Suarez then described the design process, starting with site analysis and community engagement to honor Bell Harbor's cultural heritage.

They presented three preliminary design concepts including, a shallow floor plan with elevated spaces for flood resilience, a civic space featuring a grand staircase and garden and rooftop council chamber with a terrace and atrium. They said it was important to get feedback from Village leaders and the community to refine the design, to ensure alignment with the Village's vision.

Councilman Sklar asked for the projected timeline for the design and construction document (CD) phases of the project, to which they estimated a three-month period for the design phase, followed by two months to complete the CDs. They said that the timeline largely depended on the Village's pace through the review process and said with a team of over 2,800 staff members, they assured the council they could adjust their speed as needed.

Councilman Wolf then asked the team to identify the project's biggest challenge or limiting factor to which they explained that while they had a predictable timeline for design and production drawings, the public engagement aspect could be a challenge. They said that since current zoning did not align with the council's program needs, they anticipated a process of community input and collaboration to address concerns like shading and building exposure. They also said that rising construction costs due to inflation could be a factor.

Councilman Wolf asked how the team's approach might differ for a Village Hall on a barrier island with unique flood risks. They said they were committed to elevating critical systems—electrical, mechanical, and emergency operation components—to protect them from floodwaters..

Councilman Sklar asked if recent State Statutes might allow the Villager to bypass a referendum for zoning changes, to which Mayor Freimark asked to postpone that discussion to a future meeting..

WJ ARCHITECTS IN COLLABORATION WITH WOLFBERG ALVAREZ & PARTNERS

Jason Jenson introduced Harold Somarriba (both from WJ Architects) and the team from Wolfberg Alvarez & Partners, Marcel Morlote and Rafael Labrada. They presented their qualifications and approach for a municipal projects, emphasizing their expertise and commitment to quality. They highlighted their extensive experience in municipal design, particularly in police stations and city halls, with over 30 years of coastal project experience and \$140 million in joint-use government projects. They said they collaborated with key partners like CGA and consultants CB Goldsmith and Jensen Hughes to ensure streamlined permitting and quality control.

They presented their familiarity with the project's requirements, shaped by their involvement since the programming phase. They presented solutions for coastal challenges, such as elevating buildings 13 feet to meet flood regulations, and proposed designs integrating distinct entrances and circulation for police, public, and staff, ensuring security and efficiency.

The presented three architectural options showcasing their flexibility and community-focused design, including spaces for public meetings, performances, and events to generate municipal revenue. The team reviewed their record of completing projects with no change orders and adhering to budgets, backed by a robust in-house constructability review process.

Vice Mayor Salver asked about potential challenges, especially the need to accommodate multiple entities within the building, each with specific security and functional needs. The team outlined strategies for effective navigation, multiple secure pathways, and designated areas that cater to different visitors, including a safe room for those in distress. They reviewed their experience in municipal projects, noting that they are comfortable managing stakeholder input and achieving consensus.

Councilman Sklar asked about the lead times for design and construction documents (CDs), to which the team responded that they could complete the design phase in two months and the CDs in another two months. They noted that their detailed preliminary plans aligned with current zoning codes, eliminating the need for zoning changes.

The team highlighted their experience in designing specialized facilities, particularly police stations, which require intricate planning due to their operational and security needs. They stressed the importance of having a knowledgeable team to navigate these challenges efficiently, ensuring adherence to schedules and budgets. They also addressed building resilience in coastal environments, referencing past projects that successfully withstood hurricanes and storm surges without significant damage.

Vice Mayor Salver asked how the team would incorporate flood-resilient design given the site's location on a barrier island, to which the team detailed their experience with similar projects, noting their strategic use of ground-level parking to protect the main building, efficient layouts for police operations, and compliance with current and forthcoming

codes. They underscored the importance of functional designs that enhance resilience while maintaining civic presence.

Vice Mayor Salver asked for a clarification of “no change orders” to which the team explained that their construction management team rigorously reviews designs to anticipate potential issues, ensuring quality control and adherence to budgets. They described their comprehensive services, including interior design, branding, landscaping, and quality control, and their focus on creating multifunctional spaces, such as parks integrated with civic facilities, to enhance community engagement.

Councilman Wolf asked about the biggest challenge of the project. The team identified the integration of multiple entities with different security and operational needs as the primary hurdle.

MC HARRY ARCHITECTS IN COLLABORATION WITH ZAS ARCHITECTS

Paul Stevens, ZAS Architects, introduced his team Lourdes Solera (MCHarry), Chris Coule and Larry Arrington, the presented his team’s vision for Bal Harbour’s new Village Hall. He said their goal was to create c a modern center of democracy reflecting the Village’s 78-year legacy and community identity.

He described the team’s international expertise and over 80 years of combined experience, designing resilient, sustainable buildings tailored to local needs, and provided examples of their projects which he said blended creativity and community focus to create visually iconic and functional spaces.

He presented design concepts that incorporated elements inspired by Bal Harbour’s geographic and historical context, such as seashells and waves, to symbolize connection to the Village’s heritage.

Mr. Stevens described a collaborative process, promising substantial community engagement to align the project with the Village’s aspirations and create a project that would serve Bal Harbour for generations.

Councilman Sklar asked about the timeline for both the design and construction phases to which the team said that the design process, with community consultations, would likely take six months, aiming for completion by April of the following year, and the construction drawings would follow, needing an additional six months, with a projected start in the spring of 2026.

Vice Mayor Salver asked about the challenges posed by the location on a barrier island, where sea level rise—whether due to human impact or natural changes. The team suggested that adjustments to the setbacks to allow room for parking, stormwater management, might be necessary.

The Vice Mayor asked if the team had evaluated the requirements for segregating the Police Station from other areas. They responded that while they had preliminary ideas regarding security, access, and separation, details like entrance placement would only be finalized in collaboration with staff and input from the community during the design process. They said that rushing the design phase could lead to cost overruns and said they were committed to a process with regular budget checks, aiming to prevent unexpected expenses.

Councilman Wolf asked what the team saw as their biggest challenge to successfully completing the project. The team said that integrating the police station with the Village while maintaining security and ensuring the feasibility of waterfront construction presented the biggest challenge.

Mr. Gonzalez confirmed the Review Committee's rankings and said that the council had the option to adjust the rankings or eliminate any firms, if they chose to do so.

Councilman Album said that he would rank WJ Architects as number one, moving Perkins and Will to number two, and keeping MC Harry's in third.

Councilman Sklar agreed with the rankings, noting his preference for WJ Architects because of their construction management experience, particularly with waterfront projects that had faced numerous change orders. He emphasized that WJ's approach would help prevent such issues.

Vice Mayor Salver asked Matilde Reyes Capital Program Director, to provide further detail on how the firms were ranked. Ms. Reyes said that the ranking process was twofold: the firms first submitted qualifications, followed by presentations to the committee. She said the committee looked beyond the qualifications and evaluated the presentations and how each firm would approach the project. She said that the first two firms were very close in scoring, and while both had strengths, the committee's overall recommendation was to rank Perkins and Will first.

Vice Mayor Salver said that he preferred Perkins and Will due to their cohesive team structure, as opposed to the joint ventures proposed by the other firms.

Councilman Wolf agreed, adding that Perkins and Will's extensive experience with municipal projects made them a strong choice, particularly for the project's functionality.

As discussions continued, it was clear that the council leaned towards reversing the rankings, placing Perkins and Will first, and eliminating MC Harry's from consideration. The council moved to amend the resolution accordingly.

Mayor Freimark proposed that the resolution be amended to rank WJ Architects/Wolfberg Alvarez first, Perkins & Will second and omit MCHarry/Zas. There was a general consensus from the Council to amend the resolution as proposed.

MOTION: A Motion to approve the Resolution as amended was moved by Mayor Jeffrey P. Freimark and seconded by Councilman Buzzy Sklar.

VOTE: The Motion passed by unanimous voice vote (5-0).

R7B A RESOLUTION OF THE VILLAGE COUNCIL OF BAL HARBOUR VILLAGE, FLORIDA; ACCEPTING THE FLORIDA DEPARTMENT OF ENVIRONMENTAL PROTECTION (FDEP), GRANT FUNDED VILLAGE COASTAL ADAPTATION PLAN, IN COMPLIANCE WITH WORKPLAN NO. 22PLN61; PROVIDING FOR IMPLEMENTATION; PROVIDING FOR AN EFFECTIVE DATE.

Mr. Gonzalez introduced the item outlining the project's progression from a state-funded vulnerability assessment to an adaptation plan, which aims to address challenges like sea-level rise and guide future policy and administrative actions. He introduced Danielle Irwin, Cummins Cederberg.

Ms. Irwin presented details of the adaptation plan saying that it had already been reviewed by the State and would serve as a framework for future decisions, including considerations for the new Village Hall's resilience. She said the current focus was on prioritizing projects and identifying structural and non-structural solutions to enhance community resilience.

She highlighted four categories of critical assets and their vulnerabilities to tidal flooding, storm surges, rainfall, and sea level rise and showed maps that displayed flood scenarios for a 4% annual exceedance probability storm (a 25-year storm) and a 1% probability storm (a 100-year event). She showed that certain areas of the Village were particularly prone to flooding, with depths of 6 inches to a foot during storm surges.

Ms. Irwin described the growing threat of compound flooding, combining rainfall, king tides, and rising sea levels and showed projections where king tides could rise 3.5 to 5.5 feet by 2070, significantly increasing flood risks, especially when overlaid with NOAA's sea-level rise data.

She recalled recent events, such as a June storm that brought 14 inches of rain in 48 hours—equivalent to a 50-year rainfall event—causing significant flooding and provide photos that showed water rising to fire hydrants, and aerial images revealed king tide flooding already affecting the west side of Collins Avenue.

Ms. Irwin asked the question: What should the expectation be for dry streets? She explained that complete prevention of street flooding, especially during major storms, may not be realistic even with infrastructure upgrades. She emphasized managing expectations and outlined the need to prepare for adaptation to increasing flood risks..

She said the Village has completed its vulnerability assessment and is now focusing on adapting to flooding events, and following the State's recommendations for adaptation—relocation, avoidance, protection, and accommodation, these strategies are being tailored

to meet the Village's specific needs as outlined in the adaptation planning guidebook provided by the Department of Environmental Protection.

Ms. Irwin said that this approach emphasizes protection measures such as tidal flood barriers, backflow preventers, higher seawalls, and blue-green infrastructure, which includes floodable spaces to manage stormwater and drainage and on the accommodation side, plans include elevating roads, buildings, and electrical systems above flood levels or implementing flood-proofing solutions where elevation is impractical. She said that adaptation strategies are categorized into structural and policy measures.

She provided examples of structural measures including elevating roads, sidewalks and buildings, flood proofing, and improving drainage. She said seawalls are critical for protection, but their effectiveness depends on their height, with the Village's lowest seawalls posing vulnerability. She said that while the Village has already made progress in improving stormwater management through secured funding and upgrades, further enhancements are recommended in the adaptation plan.

She said that critical assets are another focal point of the plan highlighting that the future Village Hall site must be elevated above flood levels and designed with additional stormwater storage capacity. She add that while the Village maintains only a few roads, collaboration with the Florida Department of Transportation is essential to address vulnerable sections of Collins Avenue, which serves as a crucial evacuation route.

She said the adaptation plan opens up new funding opportunities, such as applying for Resilient Florida grants for tools like mobile LIDAR, seawall inventories, and future updates to the vulnerability assessment.

Lastly she provided a summary if future projects including a major flood control and coastal erosion project which she said will begin in early 2025, led by the U.S. Army Corps and the County, and a beach renourishment effort, involving 176,000 cubic yards of material, which will play a significant role in protecting the Village from future flooding and erosion challenges.

MOTION: A Motion to approve the Resolution was moved by Mayor Jeffrey P. Freimark and seconded by Vice Mayor Seth E. Salver.

Neca Logan, 64 Camden Drive, shared her experience of a recent heavy rain event, explaining how water flow from the Haulover Bridge caused flooding in lower-lying areas, worsened by high sea levels. She also pointed out that repaving projects in the gated community have lowered road levels, preventing effective drainage into the bay. She said she supported raising seawalls but stressed the importance of implementing proper drainage solutions for rainwater.

VOTE: The Motion passed by unanimous voice vote (5-0).

R7C A RESOLUTION OF THE VILLAGE COUNCIL OF BAL HARBOUR VILLAGE, FLORIDA; APPROVING THE ADDITIONAL SERVICES PROPOSAL FROM BRIGHTVIEW LANDSCAPE SERVICES, INC., FOR THE VEGETATIVE MANAGEMENT OF THE BAL HARBOUR BEACH VEHICLE ACCESS ROAD AS DETAILED WITHIN PROPOSAL NO. 8490340, IN THE AMOUNT NOT TO EXCEED NINETY-FOUR THOUSAND NINE HUNDRED TWELVE DOLLARS (\$94,912), ROUNDED UP TO THE NEAREST DOLLAR; PROVIDING FOR IMPLEMENTATION; PROVIDING FOR AN EFFECTIVE DATE.

This item was considered a 9:01 P.M following Agenda Item R9A. Mr. Gonzalez introduced the item saying that it regarded a proposal for landscaping and vegetative management along the Beach Access Road, specifically addressing concerns about pedestrian, cyclist, and dog walker interactions in this shared space.

John Oldenburg, Director of Public Works and Beautification, described the project which he said aimed to widen the walking path without destroying the vegetation, which he said was critical for maintaining the aesthetic value of the green belt along the coastline. He described the proposal which included the removal of some existing trees, like coconut palms, which were seen as less effective in providing shade compared to the more prominent sea grape trees. He said new canopy trees were also planned for installation to further improve the shaded areas, with 16 new trees expected to be added.

He said the project also proposed relocating seating areas to areas with better shade coverage and ensuring the space remained safe for all users.

There was a general consensus from the Council expressing appreciation for the work done on the proposal, acknowledging the contributions of those involved in the planning, including former Assistant Mayor Patricia Cohen.

MOTION: A Motion to approve the Resolution was moved by Councilman Buzzy Sklar and seconded by Vice Mayor Seth E. Salver.

Babak Raheb, 128 Balfour Drive, expressed his concerns that removing vegetation could reduce the area's flood protection.

VOTE: The Motion passed by unanimous voice vote (4-0).

R9 - NEW BUSINESS AND COUNCIL DISCUSSION

R9A Discussion Item - Relocation Of Electrical Equipment To The Front Of Homes
- Councilman David Wolf

This item was heard at 8:53 P.M.

Mr. Gonzalez introduced the item explaining that the Village had been working with the Gated Community for years to address the power grid. He explained that the issue had been complicated by Florida Power and Light's (FP&L) requirement for easement agreements from homes in the area. He said the goal was to move electrical connections from the rear of the properties to the front of the homes, which would require these easements. He said that FP&L had indicated that while they could not require easements through their tariffs, they might enforce a local ordinance if one existed, which was the purpose of this discussion.

Councilman Wolf said that the Village had taken proactive steps to move this project forward. He said as homes in the neighborhood were rebuilt or replaced with larger structures, the demand for utilities increased, and addressing the outdated and hazardous grid was becoming more urgent. He said that although the process would take time, it was crucial to start the work to avoid future dangers and power outages.

Neca Logan, 64 Camden Drive and President of the Bal Harbour Civic Association added that during a recent FP&L meeting, the idea of creating an ordinance had come up, especially since FP&L had previously required some residents to place transformers in the front of their homes. She said that this was an opportunity to start the process for the entire community as homes were renovated or replaced and that the Civic Association was supportive of the idea of requesting an ordinance.

There was a general consensus from the Council to have the Village Attorney draft an ordinance that would require easements from homeowners and mandate that utilities be connected from the front of properties.

Councilman Wolf left the meeting at 9:00 P.M.

R9B Discussion Item - Pickle Ball Courts - Councilman Buzzy Sklar

Councilman Sklar introduced the item proposing that a pickle ball court be installed adjacent to the parking area under the Haulover Bridge. He explained that the initial idea was for a passive park, but after considering the area's potential, he suggested transforming it into an active park. He noted that pickleball was an increasingly popular sport and that a dedicated pickleball court would be an excellent addition to the community, especially since there were already makeshift courts set up on a basketball court.

Councilman Sklar emphasized the benefits of such an active amenity, particularly since the village lacked many options for active recreation. He mentioned the possibility of securing health grants to fund the project, with the goal of making it a "zero-net-cost" to the village. He suggested conducting a community survey to gauge public interest before proceeding.

Mr. Gonzalez suggested coordinating with the Florida Department of Transportation (FDOT) regarding the jetty project, as the area under the bridge was initially intended to be a staging area for that work.

Councilman Sklar added that conversations with neighboring businesses had already been positive, noting they were more concerned about maintaining their truck turnaround access than about the type of park being built.

There was a general consensus from the Council to survey the community on the proposed park.

R9C - PUBLIC COMMENT

Councilman Sklar praised Officer George Weisman and the Miami-Dade Fire & Rescue for the quick response to his recent health emergency and urged everyone to stay healthy and active, stressing how crucial a healthy lifestyle had been in his recovery.

Penny Sepler, 10275 Collins Avenue, highly praised the Waterfront Park programs but expressed her concerns about the Village's available parking. She also raised a concern about traffic flow, suggesting that the exit from the Shops could be better organized to reduce bottlenecks, especially as the area prepared for the busy season.

R10 - VILLAGE MANAGER REPORT

R11 - VILLAGE CLERK REPORT

R11A Lobbyist Report

R12 - VILLAGE ATTORNEY REPORT

R12A Monthly Attorney Report

END OF REGULAR AGENDA

ADJOURNMENT - The meeting was adjourned at 8:13 PM.

Mayor Jeffrey Freimark



Attest:

Dwight S. Danie, Village Clerk

BAL HARBOUR

- VILLAGE -

COUNCIL ITEM SUMMARY

Condensed Title:

A RESOLUTION OF THE VILLAGE COUNCIL OF BAL HARBOUR ACCEPTING THE DETERMINATION OF THE VILLAGE BUILDING OFFICIAL THAT TOSCANA DIVINO LLC, DBA TOSCANINO HARBOUR HOUSE APPLICATION TO THE STATE OF FLORIDA DEPARTMENT OF ALCOHOLIC BEVERAGES AND TOBACCO FOR THE RESTAURANT'S 2COP LICENSE THAT IS LOCATED INSIDE THE HARBOUR HOUSE CONDOMINIUM RESTAURANT IS COMPATIBLE WITH VILLAGE ZONING REGULATIONS.

Issue:

Should the Village Council accept the determination of the Village Building Official for the Toscano Divino LLC D/B/A Toscanino Harbour House, application for 2COP State of Florida Department of Alcoholic Beverages and Tobacco?

The Bal Harbour Experience:

- | | | |
|---|--|--|
| <input type="checkbox"/> Beautiful Environment | <input checked="" type="checkbox"/> Safety | <input type="checkbox"/> Modernized Public Facilities/Infrastructure |
| <input checked="" type="checkbox"/> Destination & Amenities | <input type="checkbox"/> Unique & Elegant | <input type="checkbox"/> Resiliency & Sustainable Community |

Item Summary / Recommendation:

Harbour House Condominium located at 10275 Collins Ave, in the Village's Oceanfront District, has engaged a new Food and Beverage operator to operate Sardinia Harbour House. Toscana Divino d/b/a Toscanino Harbour House has submitted DBPR ABT - 6001 - Division of Alcoholic Beverages and Tobacco Application to the State of Florida Department of Business and Professional Regulation for a 2COP Alcoholic Beverage License. As part of said application, the zoning authority governing the business location is required to review and sign the application for approval. In the Village, the zoning authority is the Village Building Official.

I am recommending the Village Council review the application for a liquor license, submitted by Toscana Divino LLC D/B/A Toscanino Harbour House the 2COP State of Florida Department of Alcoholic Beverages and Tobacco license.

THE ADMINISTRATION RECOMMENDS APPROVAL OF THIS RESOLUTION.

Financial Information:

Amount	Account	Account #
X	X	X

Sign off:

Building Director Eliezer Palacio	Chief Financial Officer Claudia Dixon	Village Manager Jorge M. Gonzalez
---	---	---

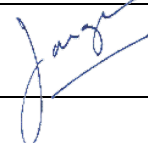

BAL HARBOUR

- VILLAGE -

COUNCIL MEMORANDUM

TO: Honorable Mayor and Village Council

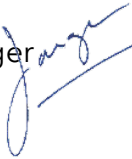
FROM: Jorge M. Gonzalez, Village Manager 

DATE: November 19, 2024

SUBJECT: **A RESOLUTION OF THE VILLAGE COUNCIL OF BAL HARBOUR VILLAGE, FLORIDA; ACCEPTING THE DETERMINATION OF THE VILLAGE BUILDING OFFICIAL THAT TOSCANA DIVINO LLC, DBA TOSCANINO HARBOUR HOUSE APPLICATION TO THE STATE OF FLORIDA DEPARTMENT OF ALCOHOLIC BEVERAGES AND TOBACCO FOR THE RESTAURANT'S 2COP LICENSE THAT IS LOCATED INSIDE THE HARBOUR HOUSE CONDOMINIUM RESTAURANT IS COMPATIBLE WITH VILLAGE ZONING REGULATIONS; PROVIDING FOR IMPLEMENTATION; PROVIDING FOR AN EFFECTIVE DATE.**

ADMINISTRATIVE RECOMMENDATION

I am recommending the Village Council review the application for a liquor license, submitted by Toscana Divino LLC, DBA Toscanino Harbour House, requesting their State of Florida Department of Alcoholic Beverages and Tobacco 2COP license series.

BACKGROUND

Harbour House Condominium located at 10275 Collins Ave, in the Village's Oceanfront District, has engaged a new Food and Beverage operator to operate Sardinia Harbour House. Toscana Divino d/b/a Toscanino Harbour House has submitted DBPR ABT - 6001 - Division of Alcoholic Beverages and Tobacco Application to the State of Florida Department of Business and Professional Regulation for a 2COP Alcoholic Beverage License. As part of said application, the zoning authority governing the business location is required to review and sign the application for approval. In the Village, the zoning authority is the Village Building Official. As part of the application review, the Building Official examined the Village Zoning Code. The Business district zoning regulations and Section. 4-3. - *Sale prohibited in filling stations, theaters; sales near churches, schools* dictate the permissible locations of such establishments. Such section reads:

- (a) *No liquor, beer or wine shall be sold in any gasoline filling station or motion picture theater, including any room opening directly or indirectly into or having a direct connection with any motion picture theater.*
- (b) *No liquor, beer or wine shall be sold within 300 feet of any church, nor within 300 feet of any public-school property, nor any property upon which there is maintained a private school operated for the instruction of minors in the common branches of learning, except such places of business as were established at the time*

of the adoption of this section. In ascertaining the proximity of any school or church referred to in this subsection, the method of measurement shall be made or taken from the main or front entrance of the church or school or the main or front place of such business along the route of ordinary pedestrian traffic along the public thoroughfare.

The Toscanino Harbour House location complies with the above Village Code provision. Therefore, zoning approval may be granted.

Historically, however, the Village Council has approved such license requests via Resolution. Records show that there are dozens of locations on Collins Avenue that have been granted licenses to sell alcoholic beverages. There are also several locations in similar zoning districts with active licenses to sell alcoholic beverages, such as the one being sought by Toscanino Harbour House.

Some of the residential locations include:

- Bal Harbour 101 Restaurant located at 10155 Collins Avenue
- Bal Harbour Tower Condo located at 9999 Collins Avenue
- The Ballerina Beach Club located at 10201 Collins Avenue
- The Palace Café located at 10101 Collins Avenue
- The Balmoral Restaurant located at 9801 Collins Avenue

Some of the non-residential locations that have active licenses to sell alcoholic beverages include:

- Sea View Terrace Restaurant at 9909 Collins Avenue
- Pool Bar and Grill at 10295 Collins Avenue (Ritz-Carlton)
- Artisan Beach House at 10295 Collins Avenue (Ritz-Carlton)
- Café Avenue 31 at 9700 Collins Ave
- ABA Restaurant at 9700 Collins Ave
- Le Zoo Restaurant at 9700 Collins Ave

ANALYSIS

Toscanino Harbour House is the new food and beverage operator that will replace the existing Sardinia Harbour House. Their current 2COP alcoholic beverage license permits the sale of beer, wine, and liquor for consumption on the licensed premises. This application is to reflect the new food and beverage operator.

THE BAL HARBOUR EXPERIENCE

The Department of Business and Professional Regulation requires Businesses to apply for and obtain an Alcoholic Beverage license. By enforcing this regulation, the Village furthers our mission of being the safest residential community with the highest quality of life for our residents and visitors from around the world.

CONCLUSION

The Toscanino Harbour House location complies with the Village zoning regulations for establishments authorized to sell alcoholic beverages. Therefore, I am recommending approval of this Resolution.

Attachments:

1. Toscana Divino LLC D/B/A Toscanino Harbour House DBPR ABT-6001
2. Toscanino Harbour House Condo Letter

RESOLUTION NO. 2024_____

A RESOLUTION OF THE VILLAGE COUNCIL OF BAL HARBOUR VILLAGE, FLORIDA; ACCEPTING THE DETERMINATION OF THE VILLAGE BUILDING OFFICIAL THAT TOSCANA DIVINO LLC, DBA TOSCANINO HARBOUR HOUSE APPLICATION TO THE STATE OF FLORIDA DEPARTMENT OF ALCOHOLIC BEVERAGES AND TOBACCO FOR THE RESTAURANT'S 2COP LICENSE THAT IS LOCATED INSIDE THE HARBOUR HOUSE CONDOMINIUM RESTAURANT IS COMPATIBLE WITH VILLAGE ZONING REGULATIONS; PROVIDING FOR IMPLEMENTATION; PROVIDING FOR AN EFFECTIVE DATE.

WHEREAS, Toscanino Harbour House is a restaurant located within the Harbour House Condominium at 10275 Collins Avenue, and Toscana Divino LLC d/b/a Toscanino Harbour House restaurant has submitted an application to the State of Florida Division of Alcoholic Beverages and Tobacco 2COP license for the sale of beer and wine (the "Application"); and

WHEREAS, the Application contains a section for completion of the Village confirming that the Application complies with the Village zoning regulations regarding the sale of alcoholic beverages; and

WHEREAS, the Village Building Official is generally charged with implementing Chapter 21, Zoning; and

WHEREAS, the Village Building Official has determined that the Application is compatible with Village zoning regulations.

NOW THEREFORE, BE IT RESOLVED BY THE VILLAGE COUNCIL OF BAL HARBOUR VILLAGE, FLORIDA, AS FOLLOWS:

Section 1. Recitals Approved. That the above stated recitals are hereby adopted and confirmed.

Section 2. Determination Accepted. That the determination of the Village Building Official that the Application is compatible with the Village zoning regulations is hereby accepted.

Section 3. Implementation. That the Village Manager is hereby directed to take any action necessary to implement the purposes of this Resolution.

Section 4. Effective Date. That this Resolution shall take effect immediately upon the adoption hereof.

PASSED AND ADOPTED this 19th day of November 2024.



Mayor Jeffrey P. Freimark

ATTEST:

Dwight S. Danie, Village Clerk

APPROVED AS TO FORM AND LEGAL SUFFICIENCY:

Village Attorney
Weiss Serota Helfman Cole & Bierman P.L.

**DBPR ABT-6001 – Division of Alcoholic Beverages and Tobacco
Application for New Alcoholic Beverage License**

**STATE OF FLORIDA
DEPARTMENT OF BUSINESS AND PROFESSIONAL REGULATION**

**DBPR Form
ABT-6001
Revised 08/2013**

If you have any questions or need assistance in completing this application, please contact the Division of Alcoholic Beverages & Tobacco's (AB&T) local district office. Please submit your completed application and required fee(s) to your local district office. This application may be submitted by mail, through appointment, or it can be dropped off. A District Office Address and Contact Information Sheet can be found on AB&T's web site at the link provided below:

http://www.myflorida.com/dbpr/abt/district_offices/licensing.html

SECTION 1 - CHECK LICENSE CATEGORY				
License Series Requested 2COP	Type/Class Requested 305-904-7873	Do you wish to purchase a Temporary License? <input checked="" type="checkbox"/> Yes <input type="checkbox"/> No		
Child License Requested	Number of Child Licenses Requested			
<input checked="" type="checkbox"/> Retail Alcoholic Beverages	<input type="checkbox"/> Alcoholic Beverage Manufacturer			
<input type="checkbox"/> Beer/Wine/Liquor Wholesaler	<input type="checkbox"/> Passenger Waiting Lounge			
<input type="checkbox"/> Retail Tobacco Products Dealer Permit (must check one or more of the below)				
<input type="checkbox"/> Pipes <input type="checkbox"/> Over the Counter <input type="checkbox"/> Vending Machine				
SECTION 2 – LICENSE INFORMATION				
If the applicant is a corporation or other legal entity, enter the name and the document number as registered with the Florida Department of State Division of Corporations on the line below.				
FEIN Number 27-2908999	Business Telephone Number	E-Mail Address (Optional) tom@toscanadivino.com		
Full Name of Applicant(s): (This is the name the license will be issued in) TOSCANA DIVINO LLC				Department of State Document # L10000066572
Business Name (D/B/A) TOSCANINO HARBOUR HOUSE				
Location Address (Street and Number) 10275 COLLINS AVENUE				
City BAL HARBOUR	County MIAMI-DADE	State FL	Zip Code 33154	
Mailing Address (Street or P.O. Box) 66 WEST FLAGLER ST. 9TH FLOOR				
City MIAMI		State FL	Zip Code 33130	
Contact Person - This section is optional, see application instructions for details				
Contact Person TOMMASO MORELATO		Telephone Number ext.		
E-Mail Address (Optional) tom@toscanadivino.com				
Mailing Address (Street or P.O. Box) 66 West Flagler St., 9th Floor				
City MIAMI		State FL	Zip Code 33130	

ABT District Office Received Date Stamp

SECTION 3 – RELATED PARTY PERSONAL INFORMATION

This section must be completed for each person directly connected with the business, unless they are a current licensee.

1.	Business Name (D/B/A) TOSCANINO HARBOUR HOUSE					
2.	Full Name of Individual (CURRENT LICENSEE - SEE LICENSEE UPDATE)					
	Social Security Number*			Home Telephone Number		Date of Birth
	Race	Sex	Height	Weight	Eye Color	Hair Color
3.	Are you a U.S. citizen? <input type="checkbox"/> Yes <input type="checkbox"/> No If no, immigration card number or passport number:					
4.	Home Address (Street and Number)					
	City				State	Zip Code
5.	Do you currently own or have an interest in any business selling alcoholic beverages, wholesale cigarette or tobacco products, or a bottle club? <input type="checkbox"/> Yes <input type="checkbox"/> No If yes, provide the information requested below. The location address should include the city and state.					
	Business Name (D/B/A)				License Number	
	Location Address					
6.	Have you had any type of alcoholic beverage , or bottle club license, or cigarette, or tobacco permit refused, revoked or suspended anywhere in the past 15 years? <input type="checkbox"/> Yes <input type="checkbox"/> No If yes, provide the information requested below. The location address should include the city and state.					
	Business Name (D/B/A)				Date	
	Location Address					
7.	Have you been convicted of a felony within the past 15 years? <input type="checkbox"/> Yes <input type="checkbox"/> No If yes, provide the information requested below and provide a Copy of the Arrest Disposition , as requested in the Application Requirements checklist.					
	Date		Location			
	Type of Offense					
8.	Have you been convicted of an offense involving alcoholic beverages or tobacco products anywhere within the past 5 years? <input type="checkbox"/> Yes <input type="checkbox"/> No If yes, provide the information requested below and provide a Copy of the Arrest Disposition , as requested in the Application Requirements checklist.					
	Date		Location			
	Type of Offense					

9.	Have you been arrested or issued a notice to appear in any state of the United States or its territories within the past 15 years? <input type="checkbox"/> Yes <input type="checkbox"/> No If yes, provide the information requested below and a Copy of the Arrest Disposition. Attach additional sheet if necessary.		
	<table border="1"> <tr> <td data-bbox="289 304 544 357">Date</td> <td data-bbox="544 304 1429 357">Location</td> </tr> </table>	Date	Location
Date	Location		
	Type of Offense		
10.	Do you meet the standards of the moral character rule? <input type="checkbox"/> Yes <input type="checkbox"/> No		
11.	Are you an officer or employee of the Division of Alcoholic Beverages and Tobacco; are you a sheriff or other state, county, or municipal officer, including reserve or auxiliary officers, certified by the state as such, with arrest powers, whose certification is current and active? <input type="checkbox"/> Yes <input type="checkbox"/> No		
NOTARIZATION STATEMENT			
"I swear under oath or affirmation under penalty of perjury as provided for in Sections 559.791, 562.45 and 837.06, Florida Statutes, that I have fully disclosed any and all parties financially and or contractually interested in this business and that the parties are disclosed in the Disclosure of Interested Parties of this application. I further swear or affirm that the foregoing information is true and correct."			
STATE OF _____			
COUNTY OF _____			
APPLICANT SIGNATURE _____			
The foregoing was () Sworn to and Subscribed OR () Acknowledged before me this _____ Day of _____, 20____, By _____ who is () personally (print name of person making statement) known to me OR () who produced _____ as identification.			
_____ Commission Expires: _____			
_____ Notary Public			

(ATTACH ADDITIONAL COPIES AS NECESSARY)

***Social Security Number**

Under the Federal Privacy Act, disclosure of Social Security numbers is voluntary unless a Federal statute specifically requires it or allows states to collect the number. In this instance, disclosure of social security numbers is mandatory pursuant to Title 42 United States Code, Sections 653 and 654; and sections 409.2577, 409.2598, and 559.79, Florida Statutes. Social Security numbers are used to allow efficient screening of applicants and licensees by a Title IV-D child support agency to assure compliance with child support obligations. Social Security numbers must also be recorded on all professional and occupational license applications and are used for licensee identification pursuant to the Personal Responsibility and Work Opportunity Reconciliation Act of 1996 (Welfare Reform Act), 104 Pub.L. 193, Sec. 317. The State of Florida is authorized to collect the social security number of licensees pursuant to the Social Security Act, 42 U.S.C. 405(c)(2)(C)(i). This information is used to identify licensees for tax administration purposes. This information is used to identify licensees for tax administration purposes, and the division will redact the information from any public records request.

**SECTION 4 – DESCRIPTION OF PREMISES TO BE LICENSED
TO BE COMPLETED BY THE APPLICANT**

Business Name (D/B/A)

TOSCANINO HARBOUR HOUSE

1.	Yes <input type="checkbox"/>	No <input checked="" type="checkbox"/>	Is the proposed premises movable or able to be moved?
2.	Yes <input type="checkbox"/>	No <input checked="" type="checkbox"/>	Is there any access through the premises to any area over which you do not have dominion and control?
3.	Yes <input type="checkbox"/>	No <input checked="" type="checkbox"/>	Is the business located within a Specialty Center? If yes, check the applicable statute: <input type="checkbox"/> 561.20(2)(b)1, F.S. or <input type="checkbox"/> 561.20(2)(b)2, F.S.
4.	Yes <input type="checkbox"/>	No <input checked="" type="checkbox"/>	Are there any mobile vehicles used to sell or serve alcoholic beverages?
5.	Yes <input type="checkbox"/>	No <input checked="" type="checkbox"/>	Are there more than 3 separate rooms or enclosures with permanent bars or counters?

Neatly draw a floor plan of the premises in ink, including sidewalks and other outside areas which are contiguous to the premises, walls, doors, counters, sales areas, storage areas, restrooms, bar locations and any other specific areas which are part of the premises sought to be licensed. A multi-story building where the entire building is to be licensed must show the details of each floor.

SEE ATTACHED

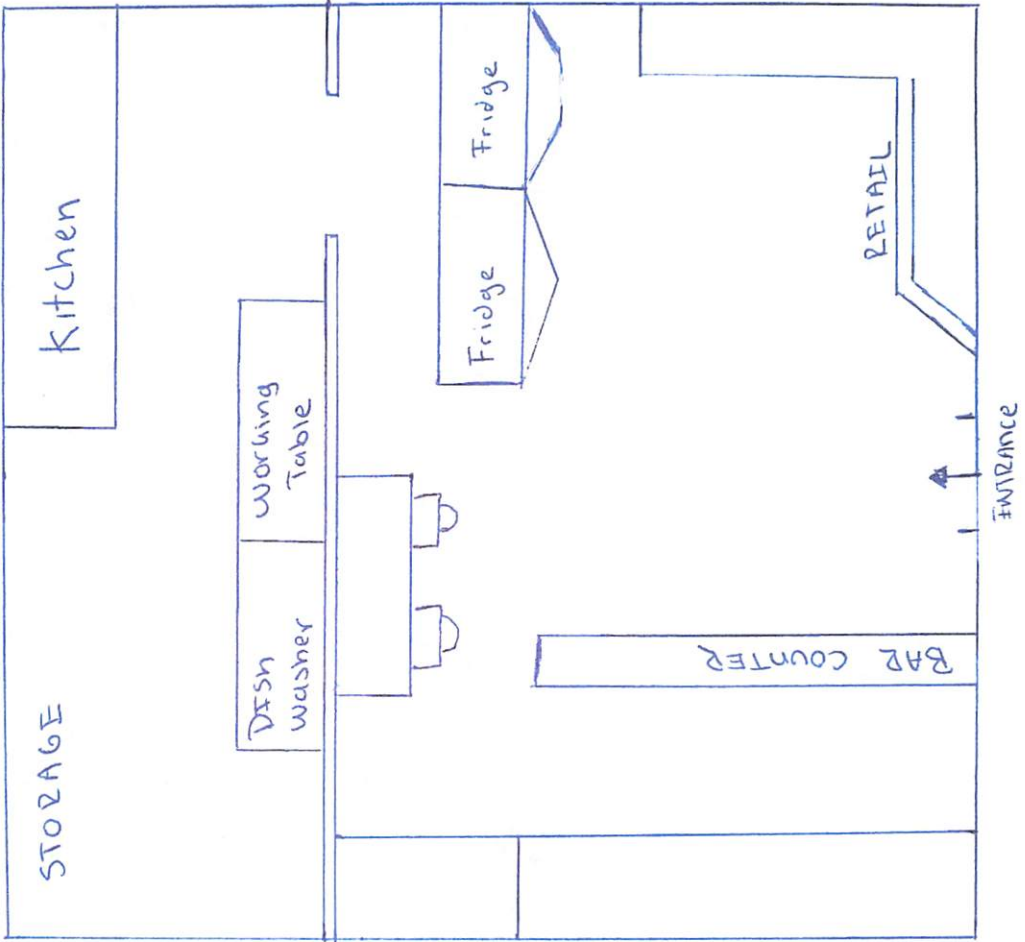

SECTION 5 – APPLICATION APPROVALS			
Full Name of Applicant: (This is the name the license will be issued in) TOSCANA DIVINO LLC			
Business Name (D/B/A) TOSCANINO HARBOUR HOUSE			
Street Address 10275 COLLINS AVENUE			
City BAL HARBOUR	County MIAMI-DADE	State FL	Zip Code 33154

ZONING TO BE COMPLETED BY THE ZONING AUTHORITY GOVERNING YOUR BUSINESS LOCATION	
<p>A. The location complies with zoning requirements for the sale of alcoholic beverages or wholesale tobacco products pursuant to this application for a Series: 2COP Type: _____ license.</p> <p>B. This approval includes outside areas which are contiguous to the premises which are to be part of the premises sought to be licensed and are identified on the sketch?" <input type="checkbox"/> Yes <input type="checkbox"/> No</p>	
<p>Check either: Please do not skip, this is important for license fee sharing <input checked="" type="checkbox"/> Location is within the city limits or <input type="checkbox"/> Location is in the unincorporated county</p>	
<p>Signed _____ Date _____</p> <p>Title _____ This approval is valid for ____ days.</p>	

SALES TAX TO BE COMPLETED BY THE DEPARTMENT OF REVENUE	
<p>The named applicant for a license/permit has complied with the Florida Statutes concerning registration for Sales and Use Tax.</p> <p>1. This is to verify that the current owner as named in this application has filed all returns and that all outstanding billings and returns appear to have been paid through the period ending _____ or the liability has been acknowledged and agreed to be paid by the applicant. This verification does not constitute a certificate as contained in Section 213.758 (4), F.S. (Not applicable if no transfer involved).</p> <p>2. Furthermore, the named applicant for an Alcoholic Beverage License has complied with Florida Statutes concerning registration for Sales and Use Tax, and has paid any applicable taxes due.</p>	
<p>Signed _____ Date _____</p> <p>Title _____ Department of Revenue Stamp</p> <p>This approval is valid for ____ days.</p>	

HEALTH TO BE COMPLETED BY THE DIVISION OF HOTELS AND RESTAURANTS OR COUNTY HEALTH AUTHORITY OR DEPARTMENT OF HEALTH OR DEPARTMENT OF AGRICULTURE & CONSUMER SERVICES	
<p>The above establishment complies with the requirements of the Florida Sanitary Code.</p>	
<p>Signed _____ Date _____</p> <p>Title _____ Agency _____</p> <p>This approval is valid for ____ days.</p>	

SECTION 6 – APPLICANT ENTITY FELONY CONVICTION

Business Name (D/B/A)

TOSCANINO HARBOUR HOUSE

Has the applicant entity been convicted of a felony in this state, any other state, or by the United States in the last 15 years?

Yes No

If the answer is "Yes," please list all details including the date of conviction, the crime for which the entity was convicted, and the city, county, state and court where the conviction took place.

(Attach additional sheets if necessary)

**SECTION 7 – SPECIAL LICENSE REQUIREMENTS
(DOES NOT APPLY TO BEER AND WINE LICENSES)**

Please check the appropriate box of the license for which you are applying. Fill in the corresponding requirements for the license type sought.

- Quota Alcoholic Beverage License Specialty Alcoholic Beverage License (e.g. SRX, S, etc)
 Club Alcoholic Beverage License

This license is issued pursuant to _____, Florida Statutes or Special Act, and as such we acknowledge the following requirements must be met and maintained:

Please initial and date:

Applicant's Initials _____ Date _____

SECTION 8 – DISCLOSURE OF INTERESTED PARTIES

Note: Failure to disclose an interest, direct or indirect, could result in denial, suspension and/or revocation of your license. You MUST list all persons and entities in the entire ownership structure. To determine which of those persons must submit fingerprints and a Related Party Personal Information, sheet, see the fingerprint section in the application instructions.

Business Name (D/B/A)

TOSCANINO HARBOUR HOUSE

1. When applicable, complete the appropriate section below. Attach extra sheets if necessary.

Title/Position	Name	Stock %
CORPORATION– List all officers, directors, and stockholders		
GENERAL PARTNERSHIP – List all general partners		
LIMITED LIABILITY COMPANY – List all managers (member & non-member), directors, officers, and members		
PRESIDENT	TOMASSO MORELATO	
LIMITED PARTNERSHIP – List all general and limited partners.		
LIMITED LIABILITY PARTNERSHIP – List all partners		

Bar Manager (Fraternal Organizations of National Scope only):

OTHER INTERESTS

These questions must be answered about this business for every person or entity listed as the applicant

1. Are there any persons or entities not disclosed who have loaned money to the business?	<input type="checkbox"/> Yes	<input checked="" type="checkbox"/> No
2. Are there any persons or entities not disclosed that derive revenue from the license solely through a contractual relationship with the licensee, the substance of which is not related to the control of the sale of alcoholic beverages, or is exempt by statute or rule?	<input type="checkbox"/> Yes	<input checked="" type="checkbox"/> No
3. Are there any persons or entities not disclosed that have the right to receive revenue based on a contractual relationship related to the control of the sale of alcoholic beverages?	<input type="checkbox"/> Yes	<input checked="" type="checkbox"/> No
4. Are there any persons or entities not disclosed who have a right to a percentage payment from the proceeds of the business pursuant to the lease?	<input type="checkbox"/> Yes	<input checked="" type="checkbox"/> No
5. Are there any persons or entities not disclosed who have guaranteed the lease or loan?	<input type="checkbox"/> Yes	<input checked="" type="checkbox"/> No
6. Are there any persons or entities not disclosed who have co-signed the lease or loan?	<input type="checkbox"/> Yes	<input checked="" type="checkbox"/> No
7. Is there a management contract, franchise agreement, or concession agreement in connection with this business?	<input type="checkbox"/> Yes	<input checked="" type="checkbox"/> No
8. Have you or anyone listed on this application, accepted money, equipment or anything of value in connection with this business from any industry member as described in 61A-1.010, Florida Administrative Code?	<input type="checkbox"/> Yes	<input checked="" type="checkbox"/> No

If you answered yes to any of the above questions, a copy of the agreement must be submitted with this application. The terms of the agreement may require the interested persons or parties related to an entity to submit fingerprints and a related party personal information sheet.

SECTION 9 - AFFIDAVIT OF APPLICANT
NOTARIZATION REQUIRED

Business Name (D/B/A)

TOSCANINO HARBOUR HOUSE

"I, the undersigned individually, or on behalf of a legal entity, hereby swear or affirm that I am duly authorized to make the above and foregoing application and, as such, I hereby swear or affirm that the attached sketch is a true and correct representation of the entire area and premises to be licensed and agree that the place of business, if licensed, may be inspected and searched during business hours or at any time business is being conducted on the premises without a search warrant by officers of the Division of Alcoholic Beverages and Tobacco, the Sheriff, his Deputies, and Police Officers for the purposes of determining compliance with the beverage and retail tobacco laws."

"I swear under oath or affirmation under penalty of perjury as provided for in Sections 559.791, 562.45 and 837.06, Florida Statutes, that the foregoing information is true and that no other person or entity except as indicated herein has an interest in the alcoholic beverage license and/or tobacco permit, and all of the above listed persons or entities meet the qualifications necessary to hold an interest in the alcoholic beverage license and/or tobacco permit."

STATE OF FLORIDA

COUNTY OF MIAMI-DADE

TOMMASO MORELATO

APPLICANT/ AUTHORIZED REPRESENTATIVE NAME

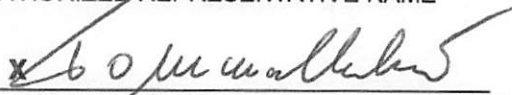

APPLICANT/ AUTHORIZED REPRESENTATIVE SIGNATURE

The foregoing was () Sworn to and Subscribed OR (X) Acknowledged before me this 16 Day

of October, 20 24, By TOMMASO MORELATO who is () personally
(print name(s) of person(s) making statement)

known to me OR (X) who produced FDL: M643 404-0 as identification.

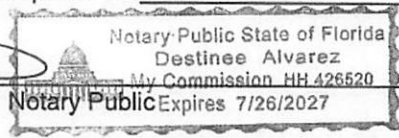
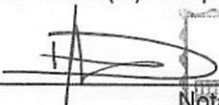

Commission Expires: _____

SECTION 10 - CURRENT LICENSEE UPDATE DATA SHEET

This section is to be completed for all current alcoholic beverage and/or tobacco license holders listed on the application to ensure the most up to date information is captured.

Business Name (D/B/A)
TOSCANINO HARBOUR HOUSE

Last Name **MORVELATO** First **TOMMASO** M.I.

Current Alcohol Beverage and/or Tobacco License Permit/Number(s)
BEV23-3599, BEV23-01626

Date of Birth **11/04/1964** Social Security Number* **896395122**

Street Address
1060 BRICHELL AVE # 2205

City **MIAMI** State **FL** Zip Code **33131**

Last Name First M.I.

Current Alcohol Beverage and/or Tobacco License Permit/Number(s)

Date of Birth Social Security Number*

Street Address

City State Zip Code

Last Name First M.I.

Current Alcohol Beverage and/or Tobacco License Permit/Number(s)

Date of Birth Social Security Number*

Street Address

City State Zip Code

Last Name First M.I.

Current Alcohol Beverage and/or Tobacco License Permit/Number(s)

Date of Birth Social Security Number*

Street Address

City State Zip Code

Last Name First M.I.

Current Alcohol Beverage and/or Tobacco License Permit/Number(s)

Date of Birth Social Security Number*

Street Address

City State Zip Code

Last Name First M.I.

Current Alcohol Beverage and/or Tobacco License Permit/Number(s)

Date of Birth Social Security Number*

Street Address

City State Zip Code



HARBOUR HOUSE CONDOMINIUM ASSOCIATION, INC.

October 4, 2024

VIA E-MAIL lrdriguez@balharbourfl.gov

Ms. Lourdes Rodriguez
Building Administrator
VILLAGE OF BAL HARBOUR
655 96th Street
Bal Harbour, Florida 33154

Re: Toscana Divino LLC
10275 Collins Avenue, Bal Harbour

Dear Ms. Rodriguez,

Harbour House (Bal Harbour) Condominium Association has engaged a new Food & Beverage Company Toscana Divino LLC, to replace the prior operator Sardinia Harbour House, so as to serve the residents of Harbour House Condominium. In that regard, please allow this letter to serve as our request for the Village to approve the application of Toscana Divino to seek the issuance of a new 2COP beer & wine license to replace the current 2COP beverage license, BEV23-36190.

Thank you for your anticipated cooperation with the above and awaiting your reply, I remain,

Sincerely,

HARBOUR HOUSE CONDOMINIUM ASSOCIATION

By: Felice Lindenkraun Secretary of BOB

BAL HARBOUR

- VILLAGE -

COUNCIL ITEM SUMMARY

Condensed Title:

A RESOLUTION APPROVING THE PURCHASE OF THREE WACKER NEUSON VERTICAL MAST LIGHT TOWERS, MODEL NO. LTV6L, FROM KELLY TRACTOR COMPANY, FOR THE VILLAGE IN THE AMOUNT NOT TO EXCEED \$41,925.

Issue:

Should the Village Council approve the Purchase of three portable light towers from Kelly Tractor Company at a cost not to exceed \$41,925?

The Bal Harbour Experience:

Beautiful Environment Safety Modernized Public Facilities/Infrastructure
 Destination & Amenities Unique & Elegant Resiliency & Sustainable Community
 Other: Cost Efficiency

Item Summary / Recommendation:

The Public Works & Beautification (PWB) and Recreation Arts and Culture (RAC), Departments frequently rent portable light towers from local vendors to support evening hours project work and Special Events throughout the Village. The increased number of Special Events within the Village and the higher cost of light tower rental fees prompted a review of the associated rental expenses, which average \$17,000 annually, to determine whether the Village should consider purchasing these towers. Research identified and obtained a current Florida Sheriff's Association Contract quote from Kelly Tractor Company for the purchase of the three requested light towers, at a total cost of \$41,925. The purchase cost is expected to be recovered within 3 fiscal years and produce identifiable cost savings over time. The light towers will be housed at the Public Works & Beautification Department's, North Miami Operations Facility and deployed as needed for use by all departments.

THE ADMINISTRATION RECOMMENDS THE APPROVAL OF THIS RESOLUTION.

Financial Information:

	Amount	Account	Account #
	\$20,962	Machinery & Equipment - Resort Tax Fund (Recreation)	10-72-506400
	\$21,963	Machinery & Equipment - Utility Fund	40-36-506400

Sign off:

Director Public Works & Beautification Department	Chief Financial Officer	Village Manager
John Oldenburg	Claudia Dixon	Jorge M. Gonzalez



BAL HARBOUR

- V I L L A G E -

COUNCIL MEMORANDUM

TO: Honorable Mayor and Village Council

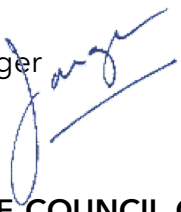
FROM: Jorge M. Gonzalez, Village Manager 

DATE: November 19, 2024

SUBJECT: **A RESOLUTION OF THE VILLAGE COUNCIL OF BAL HARBOUR VILLAGE, FLORIDA; APPROVING THE PURCHASE OF THREE WACKER NEUSON VERTICAL MAST LIGHT TOWERS, MODEL NO. LTV6L, FROM KELLY TRACTOR COMPANY FOR THE VILLAGE, IN THE AMOUNT NOT TO EXCEED FORTY-ONE THOUSAND NINE HUNDRED TWENTY-FIVE DOLLARS (\$41,925); PROVIDING FOR IMPLEMENTATION; PROVIDING FOR AN EFFECTIVE DATE.**

ADMINISTRATIVE RECOMMENDATION

I am recommending approval of this Resolution.

BACKGROUND

The Public Works & Beautification (PWB) and Recreation Arts and Culture (RAC), Departments frequently rent portable light towers from local vendors to support evening hours project work and Special Events throughout the Village. The recent annual cost of renting this equipment averages seventeen thousand dollars (\$17,000), depending on the number of Special Events and evening hours project work.

The increased number of Special Events within the Village and the higher cost of light tower rental fees prompted a review of the associated rental expenses, which average \$17,000 annually, to determine whether the Village should consider purchasing these towers. According to the American Society of Appraisers' (ASA), September 2024 publication, *Valuing Machinery and Equipment: The Fundamentals of Appraising Machinery and Technical Assets, Fourth Edition*, the useful life for the trailer mounted light towers, ranges from 5 to 10 years, dependent on usage. The current Village use for rental towers is periodic and not continuous.

Based on periodic and not continuous use, we believe that the useful life of Village owned light towers to be 8 to 12 years. Also, the average rental cost associated with the rental of these light towers, of \$17,000, annually, would be recouped within three (3) fiscal years and produce identifiable cost savings over time.

Additionally, if approved and procured, the light towers immediate availability will eliminate delays or shortages that may occur when relying on rentals, especially during emergency situations or unplanned events.

The funding to procure three (3) light towers was approved during the adoption of the Village FY 24/25 Operating Budget and Capital Plan.

ANALYSIS

To proceed, staff conducted research and located a current Florida Sheriff's Association Contract quote from Kelly Tractor Company, under Contract No. FSA23-EQU21.0. for the purchase of the three requested light towers, at a total cost of forty-one thousand nine hundred twenty-five dollars (\$41,925). The Wacker Neuson LTV6L light towers combine the features and performance of traditional light towers in a small footprint. They are suited for illuminating general job sites, site prep, concrete pours, specialty events, parking lots, road work and bridge work. The four (4) LED lamps, mounted on an adjustable vertical mast, extend 23 feet and can rotate 360 degrees for optimum lighting flexibility. Each light tower has a standard warranty period of two (2) years/2000 hours Parts and Labor. The light towers will be housed at the Public Works & Beautification Department's, North Miami Operations Facility and deployed as needed for use by all departments.

THE BAL HARBOUR EXPERIENCE

This action is aligned with the Village's stated mission through the *Bal Harbour Experience*. The purchase of equipment which can be utilized by all operational departments, in lieu of paying rental fees, corresponds directly to the goal of Safety, Modernized Public Facilities and Infrastructure and can be considered cost effective.

CONCLUSION

The increased number of Special Events within the Village and the higher cost of light tower rental fees prompted a review of the associated rental expenses which average \$17,000 annually, to determine whether the Village should consider purchasing these towers.

Research identified and obtained a current Florida Sheriff's Association Contract quote from Kelly Tractor Company for the purchase of the three requested light towers, at a total cost of forty-one thousand nine hundred twenty-five dollars (\$41,925). The purchase cost is expected to be recovered within 3 fiscal years and produce identifiable cost savings over time. The light towers will be housed at the Public Works & Beautification Department's, North Miami Operations Facility and deployed as needed for use by all departments.

I have reviewed the proposal submitted by Kelly Tractor Company and consider the cost to be appropriate for the equipment requested. Consequently, I am recommending the approval of the purchase of three (3) Wacker Neuson trailer mounted portable light towers, as specified within the Florida Sheriff's Association Contract quote from Kelly Tractor Company at a cost not to exceed \$41,925.

Attachments:

1. Kelly Tractor Company Quote - Contract No. FSA23-EQU21.0

RESOLUTION NO. 2024-____

A RESOLUTION OF THE VILLAGE COUNCIL OF BAL HARBOUR VILLAGE, FLORIDA; APPROVING THE PURCHASE OF THREE WACKER NEUSON VERTICAL MAST LIGHT TOWERS, MODEL NO. LTV6L, FROM KELLY TRACTOR COMPANY FOR THE VILLAGE, IN THE AMOUNT NOT TO EXCEED FORTY-ONE THOUSAND NINE HUNDRED TWENTY-FIVE DOLLARS (\$41,925); PROVIDING FOR IMPLEMENTATION; PROVIDING FOR AN EFFECTIVE DATE.

WHEREAS, the increased number of Special Events within the Village and the highercost of light tower rental fees, prompted a review of the associated rental expenses which average \$17,000 annually, to determine whether the Village should consider purchasing these towers; and

WHEREAS, research identified and obtained a current Florida Sheriff's Association Contract quote from Kelly Tractor Company for the purchase of the three requested light towers, at a total cost of \$41,925; and

WHEREAS, this Council has determined that it is cost-effective and in the best interest of the Village to purchase the three portable light towers from Kelly Tractor Company in the amount not to exceed \$41,925 for the Public Works & Beautification Department.

NOW, THEREFORE, BE IT RESOLVED BY THE VILLAGE COUNCIL OF BAL HARBOUR VILLAGE, FLORIDA, AS FOLLOWS:

Section 1. Recitals Adopted. That the above stated recitals are hereby adopted and confirmed.

Section 2. Purchase Approved. That the purchase of three portable light towers for the Public Works & Beautification Department, from Kelly Tractor Company at a cost of \$41,925, is hereby approved.

Section 3. Implementation. That the Village Manager is hereby authorized to take all actions necessary to implement the purposes of this Resolution.

Section 4. Effective Date. That this Resolution shall take effect immediately upon the adoption hereof.

PASSED AND ADOPTED this 19th day of November 2024.



Mayor Jeffrey P. Freimark

ATTEST:

Dwight S. Danie, Village Clerk

APPROVED AS TO FORM AND LEGAL SUFFICIENCY:

Village Attorney
Weiss Serota Helfman Cole & Bierman P.L.



Kelly Tractor Co.
 Serving the Industry Since 1933
 ktccar@kellytractor.com
 www.kellytractor.com

**WACKER
 NEUSON**



June 12, 2024
 Bal Harbour Village
 Attn: Bryan Bucher

REF: Florida Sheriff's Association Contract quote.
Term: October 1, 2023 – September 30, 2025
Contract: FSA23-EQU21.0, Equipment
Group: LIGHT TOWER – Trailer Mounted
Item: 205, Wacker Neuson LTV6L-LED

New Wacker Neuson LTV6L Compact Vertical Mast Light Tower with LED Lights:

Base Price:	LTV6L	\$13,889
5100028693:	LTV6L-Light Tower, 60HZ, Kohler Engine	
Option:	L_LIGHTING_009 (4) 300W LED Lights	\$ 2,922
	LTV6L-LED Unit Total	\$16,811
	*Less Additional Dealer Discount	\$ -2,836
	Quote Price	\$13,975

<u>Qty</u>	<u>Description</u>	<u>Unit Price</u>	<u>Extended Price</u>
3	LTV6L LED	\$13,975	\$41,925

Quote Grand Total \$41,925

*Additional Dealer Discount applies to in-stock inventory only. Subject to availability.

FOB: Bal Harbour Village
 Standard Warranty: 2 years/2000 hours Parts and Labor
 Thank you for consideration of our product. Quote is valid for thirty days.
 Greg Bennett
 Governmental Sales
 Office 305-592-5360
 Direct 786-579-2651
 Cell 786-229-7037
greg_bennett@kellytractor.com
www.kellytractor.com/Governmental

Miami
 8255 NW 58 St
 Miami, FL 33166
 (305) 592-5360
 FAX (305) 477-2024

Davie
 2801 Reese Rd
 Davie, FL 33314
 (954) 581-8181
 FAX (954) 581-6464

West Palm Beach
 5450 Okeechobee Blvd
 West Palm Beach, FL 33417
 (561) 683-1231
 FAX (561) 683-4591

Clewisston
 801 F Sugarland Hwy
 Clewisston, FL 33440
 (863) 983-8177
 FAX (863) 992-1000

Naples
 3636 Prospect Ave
 Naples FL 34104
 (239) 403-3636
 FAX (239) 403-7510

Ft Myers
 9651 Kelly Tractor Dr
 Ft Myers, FL 33905
 (239) 693-9233
 FAX (239) 693-8876

Orlando (Cranes Only)
 17300 E Colonial Dr
 Orlando, FL 32820
 (407) 568-8055
 FAX (407) 568-7701

Light Towers - Compact Vertical Mast Light Towers



**WACKER
NEUSON**
all it takes!



Versatile light towers deliver exceptional lighting

The LTV4L and LTV6L light towers combine the features and performance of traditional light towers in a small footprint. They are ideally suited for illuminating general job sites, site prep, concrete pours, specialty events, parking lots, road work and bridge work. The adjustable vertical mast extends 23 feet and can rotate 360 degrees for optimum lighting flexibility.

- Compact design and foldable tongue allow transportation of up to 18 units on a 48 foot flatbed truck. Additionally, less space is taken up on site and in rental yards.
- Extended service intervals of 1,000 hours between oil changes lowers cost of ownership.
- Fast set-up times and a 45-gallon fuel tank extends lighting time
- Available with Kohler engines. All models feature a Mecc Alte generator end
- Metal halide or LED lamps provide lighting for any application

Light Towers - Compact Vertical Mast Dimensions

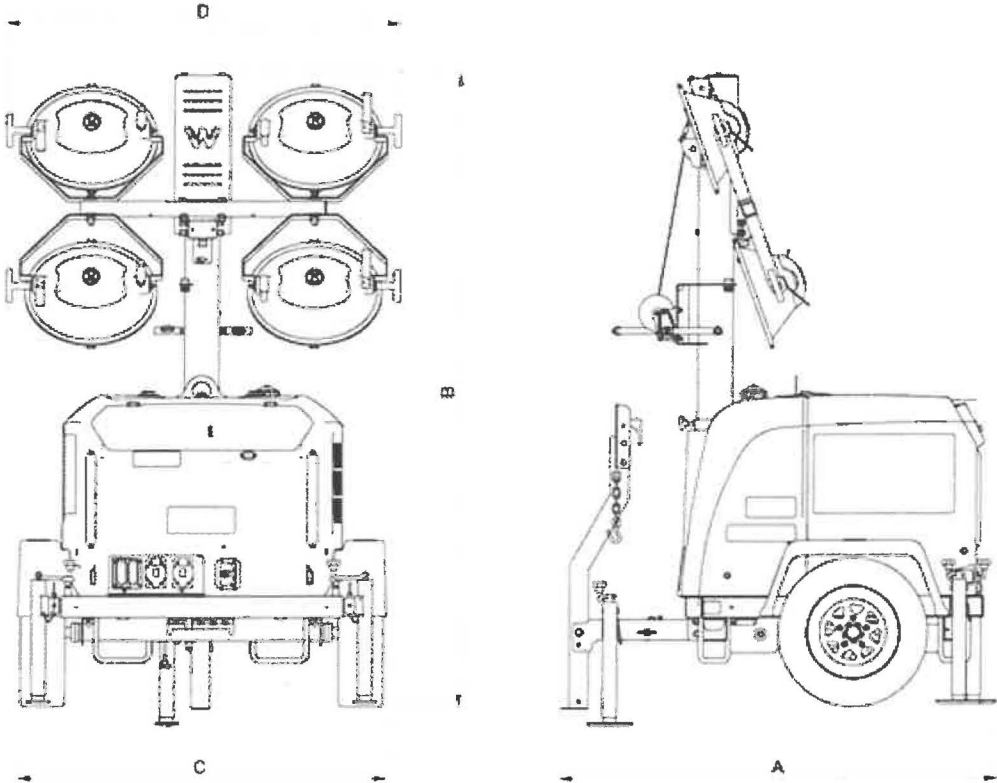

A	Length with tongue up	67 in
A	Length with tongue down	101 in
B	Mast height retracted	8.2 ft
B	Mast height extended	23 ft
C	Width with outriggers retracted	58 in
C	Width with outriggers extended	118.5 in
D	Width	62 in

Please note: that product availability can vary from country to country. It is possible that information / products may not be available in your country. More detailed information on engine power can be found in the operator's manual; the stated power may vary due to specific operating conditions. Subject to alterations and errors excepted. Applicable also to illustrations.
 Copyright © 2022 Wacker Neuson SE.

Light Towers - Compact Vertical Mast Technical specifications

	LTV4L	LTV6L	LTV6L LED
Operating data			
L x W x H in	101 x 58 x 99	101 x 58 x 99	101 x 58 x 99
Operating weight lb	1,650	1,770	1,770
Shipping weight lb	1,310	1,430	1,430
Illumination coverage at 5 fc (54 lux) ft ²	5,582	9,230	5,582
Lamp type	LED	Metal Halide	LED
Mast height ft	23	23	23
Sound level (LwA) at 23 ft (7 m) dB(A)	68.8	67.9	67.9
Power kW	4.1	6	6
Frequency Hz	60	60	60
Voltage V	120	120	120
Power factor cos Φ 1~	1	1	1
Engine / Motor			
Generator model	Brushless	Brushless	Brushless
Generator insulation (class)	H	H	H
Idle to full load %	10	10	10
Voltage control (+/-) %	6	6	6
Engine / Motor manufacturer	Kohler (KDW702)	Kohler (LDW1003)	Kohler (LDW1003)
Engine / Motor type	Liquid-cooled 2-cylinder	Liquid-cooled 3-cylinder	Liquid-cooled 3-cylinder
Fuel type	Diesel	Diesel	Diesel
Displacement in ³	41.9	62.7	62.7
Operating performance hp	8	12.2	12.2
at rpm rpm	1,800	1,800	1,800
Rated performance	ISO 3046 IFN	ISO 3046 IFN	ISO 3046 IFN
Tank capacity (Oil) US qt	5.5	4	4
Tank capacity (Fuel) US gal	45.8	45.8	45.8
Fuel consumption (Prime Load) US gal/h	0.47	0.72	0.72
Runtime 100% Prime Load h	92	60.5	60.5
Runtime 4 Lights Only h	187	98.8	151

BAL HARBOUR

- VILLAGE -

COUNCIL ITEM SUMMARY

Condensed Title:

AN ORDINANCE AMENDING CHAPTER 12 "OFFENSES" OF THE CODE OF ORDINANCES TO CREATE SECTION 12-11 "PUBLIC CAMPING OR SLEEPING" TO ESTABLISH DEFINITIONS AND REGULATIONS; PROVIDING FOR CONFLICTS; PROVIDING FOR SEVERABILITY; AND PROVIDING FOR INCLUSION IN THE CODE.

Issue:

Shall the Village Council adopt this Ordinance to amend the Code to create Section 12-11 to establish regulations regarding public camping and sleeping to be in compliance with the new State law passed by the Florida Legislature in 2024?

The Bal Harbour Experience:

Beautiful Environment Safety Modernized Public Facilities/Infrastructure
 Destination & Amenities Unique & Elegant Resiliency & Sustainable Community

Item Summary / Recommendation:

During the 2024 Florida Legislative Session, Florida House Bill (HB) 1365 passed, and Governor DeSantis signed it into law. HB 1365 prohibits counties and municipalities from authorizing or allowing individuals to regularly sleep or camp on public property, at public buildings or their grounds, or on public rights-of-way within their jurisdictions. Section 17-82 of the Village Code prohibits "any Person to, in any Public Park, . . . (5) Erect, maintain or cause to be erected or maintained any tent, shelter or structure in a Public Park." The existing prohibition in Section 17-82 does not cover all public property in the Village and is narrower in the scope of conduct prohibited than that contemplated by the new statute. Therefore, for the Village to be in compliance, the proposed amendment is recommended to be made to Chapter 12 "Offenses" of the Code of Ordinances to create Section 12-11 "Public Camping or Sleeping" to establish definitions and regulations. Violations are deemed to be a public nuisance and may subject the violator to arrest. Convictions are punishable by a fine of up to \$500.00 or imprisonment in the County jail for up to 60 days or both.

THE ADMINISTRATION RECOMMENDS APPROVAL OF THIS ORDINANCE.

Financial Information:

	Amount	Account	Account #
	X	X	X

Sign off:

Assistant Village Manager	Chief Financial Officer	Village Manager
Ramiro J. Inguanzo	Claudia Dixon	Jorge M. Gonzalez
		

BAL HARBOUR

- VILLAGE -

COUNCIL MEMORANDUM

TO: Honorable Mayor and Village Council

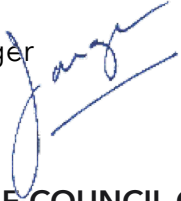
FROM: Jorge M. Gonzalez, Village Manager 

DATE: November 19, 2024

SUBJECT: **AN ORDINANCE OF THE VILLAGE COUNCIL OF BAL HARBOUR VILLAGE, FLORIDA, AMENDING CHAPTER 12 "OFFENSES" OF THE CODE OF ORDINANCES TO CREATE SECTION 12-11 "PUBLIC CAMPING OR SLEEPING" TO ESTABLISH DEFINITIONS AND REGULATIONS; PROVIDING FOR CONFLICTS; PROVIDING FOR SEVERABILITY; PROVIDING FOR INCLUSION IN THE CODE; AND PROVIDING FOR AN EFFECTIVE DATE.**

ADMINISTRATIVE RECOMMENDATION

I am recommending approval of this Ordinance.

BACKGROUND

During the 2024 Florida Legislative Session, Florida House Bill (HB) 1365 passed, and Governor DeSantis signed it into law. HB 1365 prohibits counties and municipalities from authorizing or allowing individuals to regularly sleep or camp on public property, at public buildings or their grounds, or on public rights-of-way within their jurisdictions. The law includes two significant effective dates:

- October 1, 2024 - all municipalities and counties in Florida will be required to enforce this State requirement for local bans on camping or sleeping on public property within their jurisdictions, including the beach, sidewalks, bus stops and parks.
- January 1, 2025 - all municipalities and counties in Florida could face legal action from any resident or business owner within their jurisdictions or the Florida Attorney General for failing to comply with the new State Statute. Prior to filing any legal action against any municipality or county, five (5) business days' written notice must be provided to the respective legislative body of the corresponding jurisdiction. If the resident or business owner prevails, the court could find the jurisdiction in violation of the State Statute and award reasonable attorney's fees and costs, including investigative costs.

This new State law brings a renewed sense of urgency to humanely assist those on our streets who are homeless and serves as a call to action to strategically and compassionately tackle the issue of homelessness together as a community.

Given the potential impacts across Miami-Dade County, this State law could potentially overwhelm the County's corrections facilities, which are already struggling with overpopulation. Miami-Dade County operates a coordinated system of care responsive to those experiencing homelessness through the Miami-Dade County Homeless Trust. The Trust's Continuum of Care model (CoC) has successfully reduced unsheltered homelessness by nearly 90 percent over the past three decades even while many other communities across the state and nation have seen significant increases. Even so, the affordable housing crisis has compounded the challenge of homelessness, and more than 1,000 people remain on the streets of Miami-Dade County on any given night, and close to three times that number are in emergency shelters or other temporary settings. The Trust estimates that the fastest growing population of unsheltered people in Miami-Dade County are seniors 55 and over, and families with young children.

In October 2024, the Miami-Dade County Board of County Commissioners amended a County Ordinance which provides for the prohibition on overnight camping on County-owned facilities and properties. The County Ordinance does not interpret or intend to create an offense that can be cited on any municipal property, so therefore, is not applicable in Bal Harbour Village.

Section 17-82 of the Village Code prohibits "any Person to, in any Public Park, . . . (5) Erect, maintain or cause to be erected or maintained any tent, shelter or structure in a Public Park, except when approved in writing by the Village Manager;" The existing prohibition in Section 17-82 does not cover all public property in the Village, and is narrower in the scope of conduct prohibited than that contemplated by the new statute.

Therefore, for the Village to be in compliance with the new State law, the proposed amendment is recommended to be made to Chapter 12 "Offenses" of the Code of Ordinances to create Section 12-11 "Public Camping or Sleeping" to establish definitions and regulations, providing for conflicts, providing for severability, providing for inclusion in the Code, and providing for an effective date. Violations are deemed to be a public nuisance and may subject the violator to arrest. Convictions are punishable by a fine of up to \$500.00 or imprisonment in the County jail for up to 60 days or both.

ANALYSIS

Although public camping or sleeping has not generally been an issue in Bal Harbour Village and is not something that is often dealt with by our Police Officers, it is proposed that Section 12-11 "Public Camping or Sleeping" be added to Chapter 12 "Offenses" of the Code of Ordinances as follows:

Sec. 12-11. Public Camping or Sleeping. This section shall be known as the Public Camping or Sleeping Ordinance of Bal Harbour Village, Florida.

(a) Definitions and rules of construction. The following words, terms, and phrases, when used in this section, shall have the meanings ascribed to them in this section:

(1) "Public camping or sleeping" means:

- a. Lodging or residing overnight in a temporary outdoor habitation used as a dwelling or living space and evidenced by the erection of a tent or other temporary shelter, the presence of bedding or pillows, or the storage of personal belongings; or
- b. Lodging or residing overnight in an outdoor space without a tent or other temporary shelter.

(2) "Public camping or sleeping" does not include:

- a. Lodging or residing overnight in a motor vehicle that is registered, insured, and located in a place where it may lawfully be; or
- b. Camping for recreational purposes on property designated for such purposes.

(b) Prohibitions; Penalties.

- (1) No person may regularly engage in public camping or sleeping on any public property, including, but not limited to, any public building or its grounds and any public right-of-way under the jurisdiction of or located within the Village.
- (2) If the person refuses to be taken to a shelter, and/or leave the area, the violation shall constitute a public nuisance, and may subject the violator to arrest and shall, upon conviction, be punishable either by a fine up to \$500.00, imprisonment in the county jail up to 60 days, or both.

(c) Policies and Procedures. The Village Manager or designee shall promulgate policies and procedures to guide the implementation of this section in compliance with state law.

Staff will develop the policies and procedures to guide the implementation of this section in compliance with State law and include them in the second reading of this Ordinance.

THE BAL HARBOUR EXPERIENCE

This Ordinance addresses several pillars of *The Bal Harbour Experience*, including providing for the safety of our residents and community and contributing to the beautiful environment of our Village.

CONCLUSION

The Administration recommends the adoption of the Ordinance on First reading.

ORDINANCE NO. 2024____

AN ORDINANCE OF THE VILLAGE COUNCIL OF BAL HARBOUR VILLAGE, FLORIDA, AMENDING CHAPTER 12 "OFFENSES" OF THE CODE OF ORDINANCES TO CREATE SECTION 12-11 "PUBLIC CAMPING OR SLEEPING" TO ESTABLISH DEFINITIONS AND REGULATIONS; PROVIDING FOR CONFLICTS; PROVIDING FOR SEVERABILITY; PROVIDING FOR INCLUSION IN THE CODE; AND PROVIDING FOR AN EFFECTIVE DATE.

WHEREAS, during its 2024 legislative session, the Florida Legislature enacted House Bill 1365, codified as Section 125.0231, F.S., which prohibits counties or municipalities from authorizing or otherwise allowing "any person to regularly engage in public camping or sleeping on any public property, including, but not limited to, any public building or its grounds and any public right-of-way under the jurisdiction of the county or municipality, as applicable"; and

WHEREAS, Section 17-82 of the Village Code prohibits "any Person to, in any Public Park, . . . (5) Erect, maintain or cause to be erected or maintained any tent, shelter or structure in a Public Park, except when approved in writing by the Village Manager;" and

WHEREAS, the existing prohibition in Section 17-82 does not cover all public property in the Village, and is narrower in the scope of conduct prohibited than that contemplated by the new statute; and

WHEREAS, the Village Council finds it appropriate to therefore enact this Ordinance to ensure compliance with state law; and

WHEREAS, the Village Council conducted a duly noticed first and second reading of this Ordinance, as required by law, and after having received input from and participation by interested members of the public and staff, the Village Council has determined that this Ordinance is in the best interest of the public health, safety, and welfare.

NOW, THEREFORE, BE IT ORDAINED BY THE VILLAGE COUNCIL OF BAL HARBOUR VILLAGE, FLORIDA, AS FOLLOWS:

Section 1. Recitals Adopted. That the above stated recitals are hereby adopted and confirmed.

Section 2. Village Code Amended - Chapter 12. That Chapter 12 "Offenses" of the Code of Bal Harbour Village, Florida, is hereby amended to create Section 12-11 "Public Camping or Sleeping" to read as follows:¹

CHAPTER 12. - OFFENSES

* * *

Sec. 12-11. Public Camping or Sleeping. This section shall be known as the Public Camping or Sleeping Ordinance of Bal Harbour Village, Florida.

(a) Definitions and rules of construction. The following words, terms, and phrases, when used in this section, shall have the meanings ascribed to them in this section:

(1) "Public camping or sleeping" means:

- a. Lodging or residing overnight in a temporary outdoor habitation used as a dwelling or living space and evidenced by the erection of a tent or other temporary shelter, the presence of bedding or pillows, or the storage of personal belongings; or
- b. Lodging or residing overnight in an outdoor space without a tent or other temporary shelter.

(2) "Public camping or sleeping" does not include:

- a. Lodging or residing overnight in a motor vehicle that is registered, insured, and located in a place where it may lawfully be; or
- b. Camping for recreational purposes on property designated for such purposes.

¹ Additions to existing Village Code text are shown by underline; deletions from existing Village Code text are shown by ~~strikethrough~~. Any changes between first and second reading are shown by highlighted double underline and ~~double strikethrough~~ font.

(b) Prohibitions; Penalties.

- (1) No person may regularly engage in public camping or sleeping on any public property, including, but not limited to, any public building or its grounds and any public right-of-way under the jurisdiction of or located within the Village.
- (2) If the person refuses to be taken to a shelter or leave the area, the violation shall constitute a public nuisance, and may subject the violator to arrest and shall, upon conviction, be punishable either by a fine up to \$500.00, imprisonment in the county jail up to 60 days, or both.

(c) Policies and Procedures. The Village Manager or designee shall promulgate policies and procedures to guide the implementation of this section in compliance with state law.

* * *

Section 3. Severability. That the provisions of this Ordinance are declared to be severable and if any section, sentence, clause or phrase of this Ordinance shall for any reason be held to be invalid or unconstitutional, such decision shall not affect the validity of the remaining sections, sentences, clauses, and phrases of this Ordinance but they shall remain in effect, it being the legislative intent that this Ordinance shall stand notwithstanding the invalidity of any part.

Section 4. Inclusion in the Code. That it is the intention of the Village Council, and it is hereby ordained that this Ordinance shall become and be made a part of the Bal Harbour Village Code; that the sections of this Ordinance may be renumbered or relettered to accomplish such intention; and that the word "Ordinance" shall be changed to "Section" or other appropriate word.

Section 5. Conflict. That all Sections or parts of Sections of the Code of Ordinances, all ordinances or parts of ordinances, and all resolutions, or parts of resolutions, in conflict with this Ordinance are repealed to the extent of such conflict.

Section 6. Effective Date. That this Ordinance shall become effective upon adoption on second reading.

PASSED AND ADOPTED on first reading this 19th day of November, 2024.

PASSED AND ADOPTED on second reading this ___ day of _____, 2024.



Mayor Jeffrey P. Freimark

ATTEST:

Dwight S. Danie, Village Clerk

APPROVED AS TO FORM AND LEGAL SUFFICIENCY:

Village Attorney
Weiss Serota Helfman Cole & Bierman P.L.

BAL HARBOUR

- VILLAGE -

COUNCIL ITEM SUMMARY

Condensed Title:

A RESOLUTION APPROVING THE EXPENDITURE OF LANDSCAPE AND SECURITY ASSESSMENT FUNDS FOR CERTAIN LEGAL EXPENDITURES IN THE ASSESSMENT DISTRICT IN AN AMOUNT NOT TO EXCEED FIFTY THOUSAND (\$50,000) DOLLARS; PROVIDING FOR IMPLEMENTATION; PROVIDING FOR AN EFFECTIVE DATE.

Issue:

Should the Village Council approve the BHCA engagement of the law firm of Robert Scheffel Wright, and fund legal fees from the landscape and security assessment to represent the board of directors related to FPL electrical reliability?

The Bal Harbour Experience:

Beautiful Environment Safety Modernized Public Facilities/Infrastructure
 Destination & Amenities Unique & Elegant Resiliency & Sustainable Community

Item Summary / Recommendation:

FPL has identified the need to replace and upgrade a large portion of the underground Florida Power and Light (FPL) service lines within the Gated Residential Community. While the proposed FPL Power Upgrades Project is not a Village managed project, the Village administration is participating on a limited basis while acting as an advocate and coordinating design conflict considerations related to our ongoing utility improvements. In furtherance, of the FPL power system upgrades, the BHCA Board of Directors has requested the Council commit to fund future legal fees related to existing FPL power reliability and safety issues from the landscape and security assessment funds in an amount not to exceed Fifty Thousand (\$50,000), to the law firm of Robert Scheffel Wright.

THE ADMINISTRATION RECOMMENDS THE APPROVAL OF THIS RESOLUTION.

Financial Information:

	Amount	Account	Account #
	\$50,000	Legal - Security and Landscape	11-29-503101

Sign off:

Director Public Works & Beautification Department	Chief Financial Officer	Village Manager
John Oldenburg	Claudia Dixon	Jorge M. Gonzalez

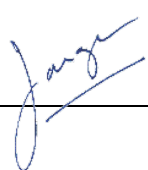

BAL HARBOUR

- VILLAGE -

COUNCIL MEMORANDUM

TO: Honorable Mayor and Village Council

FROM: Jorge M. Gonzalez, Village Manager 

DATE: November 19, 2024

SUBJECT: **A RESOLUTION OF THE VILLAGE COUNCIL OF BAL HARBOUR VILLAGE, FLORIDA; APPROVING THE EXPENDITURE OF LANDSCAPE AND SECURITY ASSESSMENT FUNDS FOR CERTAIN LEGAL EXPENDITURES IN THE ASSESSMENT DISTRICT IN AN AMOUNT NOT TO EXCEED FIFTY THOUSAND (\$50,000) DOLLARS; PROVIDING FOR IMPLEMENTATION; PROVIDING FOR AN EFFECTIVE DATE.**

ADMINISTRATIVE RECOMMENDATION

I am recommending approval of this Resolution.

BACKGROUND

The underground Florida Power and Light (FPL) service lines within the Gated Residential Community, have been identified by FPL for replacement and upgrades. This equipment is outdated, subject to flooding and in many cases, inaccessible due to heavy vegetation. FPL has developed a Project to address the identified power grid deficiencies.

FPL has completed preliminary designs to replace the existing power grid within the community and has shared these plans during several community meetings. To begin this project, FPL is required to obtain easements for the new transformer locations in front of the affected properties. The BHCA has committed to coordinating with FPL to obtain the needed easements.

In this instance, the proposed FPL Power Upgrades Project is not a Village managed project. The Bal Harbour Civic Association (BHCA), and FPL representatives are communicating directly. The Village administration is participating on a limited basis while acting as an advocate and coordinating design conflict considerations related to our existing and planned utility improvements.

Following the FPL development of a power grid upgrade project, outreach by the BHCA to the affected residents has not produced the desired outcomes. Obtaining the required FPL easements to locate the new transformers at the front of homes is projected to take several years.

The current trend of new homes construction which are twice or greater in size compared to the original home on the same site, creates greater strain on the existing aged FPL

power grid and development and amplifies the need to create an environment to systematically obtain the needed easements and enable the FPL power grid upgrades.

A Discussion Item was heard during the October 29, 2024, Council meeting related to a request of the BHCA Board of Directors, for the Council's adoption of an Ordinance to require the granting of utility easements when an owner in the gated community wants to construct a new home or redevelop a home, construct an addition to the existing home, or conduct a major home renovation.

As requested, the proposed Ordinance is scheduled to be placed on the January 2025, Village Council meeting agenda for a first reading review and discussion. The Ordinance if adopted could assist in the Gated Communities' efforts to obtain the envisioned FPL power grid upgrades in the long term.

ANALYSIS

In the interim, the BHCA Board of Directors has determined the engagement of legal representation to provide the board with advice and counsel regarding existing FPL power reliability and safety issues is in the best interest of the Community.

The BHCA has requested the Council approval of the engagement of the law firm of Gardner, Bist, Bowden, Dee, LaVia, Wright, Perry & Harper, P.A., to represent the Bal Harbour Civic Association for the envisioned services, as detailed within the attached legal representation letter from the proposed firm dated, November 04, 2024. Specifically, they seek the Village's approval to cover the legal fees associated with this representation through the landscape and security assessment funds up to \$50,000.

THE BAL HARBOUR EXPERIENCE

This action is aligned with the Village's stated mission through the *Bal Harbour Experience*. The BHCA engagement of a law firm to provide the board with advice and counsel regarding existing FPL power reliability and safety issues, corresponds directly to the goals of Safety and Modernized Public Facilities and Infrastructure.

CONCLUSION

FPL has identified the need to replace and upgrade a large portion of the underground Florida Power and Light (FPL) service lines within the Gated Residential Community. The current trend of new home construction which are significantly greater in size compared to the original home on the same site, creates greater strain on the existing aged FPL power grid and development and amplifies the need to create an environment to systematically obtain the needed easements and enable the FPL power grid upgrades.

While the proposed FPL Power Upgrades Project is not a Village managed project, the Village administration is participating on a limited basis while acting as an advocate and coordinating design conflict considerations related to our existing and planned utility improvements.

The BHCA has requested the Council approval of the engagement of the law firm of Gardner, Bist, Bowden, Dee, LaVia, Wright, Perry & Harper, P.A., to provide the board of directors with advice and counsel regarding existing FPL power reliability and safety issues as detailed within the attached legal representation letter from the proposed firm dated November 04, 2024.

I have reviewed the requested engagement letter and consider the proposed fees to be appropriate for the legal services requested. Consequently, I am recommending the approval of reimbursement of fees for the BHCA's engagement of this law firm as detailed within their Letter of Engagement, at a cost not to exceed \$50,000.

Attachments:

1. Letter of Engagement Dated November 04, 2024, law firm of Gardner, Bist, Bowden, Dee, LaVia, Wright, Perry & Harper, P.A.

RESOLUTION NO. 2024-____

A RESOLUTION OF THE VILLAGE COUNCIL OF BAL HARBOUR VILLAGE, FLORIDA; APPROVING THE EXPENDITURE OF LANDSCAPE AND SECURITY ASSESSMENT FUNDS FOR CERTAIN LEGAL EXPENDITURES IN THE ASSESSMENT DISTRICT IN AN AMOUNT NOT TO EXCEED FIFTY THOUSAND (\$50,000) DOLLARS; PROVIDING FOR IMPLEMENTATION; PROVIDING FOR AN EFFECTIVE DATE.

WHEREAS, the underground Florida Power and Light (FPL) service lines within the Gated Residential Community, have been identified by FPL for replacement and upgrades; and

WHEREAS, on November 4, 2024, the Village received correspondence directed to the Bal Harbour Civic Association ("BHCA") from Robert Scheffel Wright confirming the engagement of his law firm and obligating the BHCA to pay of future legal fees in connection with the reliability and safety of electric service provided by Florida Power and Light to customers located within the Assessment district; and

WHEREAS, the BHCA has requested Council approval of the engagement of the law firm to provide the board of directors with the legal representation regarding electric service;

WHEREAS, the Village Council has determined that it is in the best interest of the Village to commit to fund future legal fees for these activities from the landscape and security assessment funds in an amount not to exceed Fifty Thousand (\$50,000).

NOW, THEREFORE, BE IT RESOLVED BY THE VILLAGE COUNCIL OF BAL HARBOUR VILLAGE, FLORIDA, AS FOLLOWS:

Section 1. Recitals Adopted. That the above stated recitals are hereby adopted and confirmed.

Section 2. Authority to Approve Future Expenditures. That the Village Manager is hereby authorized to approve future, properly supported requests for payment of legal fees from the Landscape and Security Assessment to the BHCA for services in connection with the reliability and safety of electric service provided by Florida Power and Light to

customers located within the Assessment district only, in an amount not to exceed Fifty Thousand (\$50,000) Dollars.

Section 3. Implementation. That the Village Manager is hereby authorized to take all actions necessary to implement the purposes of this Resolution.

Section 4. Effective Date. That this Resolution shall take effect immediately upon the adoption hereof.

PASSED AND ADOPTED this 19th day of November 2024.



Mayor Jeffrey P. Freimark

ATTEST:

Dwight S. Danie, Village Clerk

APPROVED AS TO FORM AND LEGAL SUFFICIENCY:

Village Attorney
Weiss Serota Helfman Cole & Bierman P.L.



Gardner, Bist, Bowden, Dee, LaVia,
Wright, Perry & Harper, P.A.
Attorneys at Law

Michael P. Bist***
Gavin B. Bowden**
David S. Dee***
Charles R. Garbarino**
Robert A. "Gus" Harper III
John T. LaVia III
Timothy J. Perry**
Robert Richard "Eitel" Wright

1300 Thousand Oaks Drive
Tallahassee, Florida 32309
Telephone: 904.265.0020
Facsimile: 904.265.2414
www.gpwh.com

*Equal Opportunity Employer
**Not a law firm in Florida
***Not a law firm in Florida

November 7, 2024

Neca Logan, President
Bal Harbour Civic Association
Bal Harbour, Florida 33154

Re: Engagement Regarding Underground Utility Issues

Dear Ms. Logan:

As we have discussed, this letter will confirm the engagement of my law firm, Gardner, Bist, Bowden, Dee, LaVia, Wright, Perry & Harper, P.A. ("Firm") to represent the Bal Harbour Civic Association ("Association") in connection with issues relating to the reliability of electric service provided by Florida Power & Light Company ("FPL") to customers in Bal Harbour Village ("Bal Harbour" or "Village"). Those issues relate to the reliability and safety of FPL's service provided from underground electric distribution facilities, and correspondingly, issues relating to remedies and cost responsibility for ensuring the safety and reliability of electric service in the Village.

This engagement letter sets forth our understanding as to the nature and scope of the services that the Firm will provide in connection with this matter, our agreement regarding fees for the contemplated services, and the terms on which fees and costs will be charged in the course of the proposed engagement.

Scope of Representation and Services to be Provided

As we discussed, this engagement will involve our providing advice and counsel to the Bal Harbour Civic Association regarding the reliability and safety issues that we have discussed. The engagement will also likely involve negotiating with FPL toward a mutually acceptable resolution of the issues. While the Firm and I will do everything possible to achieve a negotiated resolution acceptable to the Association, we cannot guarantee such an outcome, and therefore, it is possible that the engagement could potentially involve litigation on behalf of the Association directed toward obtaining favorable results.

As we discussed, within the Firm, I will have primary responsibility for this representation. In my work on utility matters, I frequently involve two of my partners, John T. "Jay" LaVia and Timothy J. "Tim" Perry. Jay and I have been law partners for 30 years. Tim joined our Firm three years ago, but I have known and worked with him on related matters (for clients with aligned interests) for 20 years. During the course of the representation, we will expect to receive direction primarily from you and from any other Association personnel designated by you.

Fees for Services and Cost Reimbursement

The Firm will charge the Bal Harbour Civic Association for actual time expended in connection with this matter. Our rates for this representation, which represent substantial discounts from our normal rates, are set forth on the attached schedule. These rates will not be increased before January 1, 2027.

To the extent necessary, the Firm will also charge for reimbursement of certain out-of-pocket costs and expenses, together with applicable taxes, if any, including: photocopying costs, telecopying costs, all reasonable travel expenses (coach class for domestic air flights and mileage reimbursement at the then-current rate authorized by the U.S. Internal Revenue Service or by Florida Statutes, whichever is less), express courier service (e.g., Federal Express) charges, extraordinary postage (e.g. Express Mail or postage expenses for a large-volume mailing), computer research charges, court reporting fees, filing fees, and recording costs. In the event unusually large costs or expenses are anticipated, we may either request an advance deposit to cover such expenditures or request that you pay for such items directly. With respect to experts, our normal practice is to assist clients in identifying and recruiting such experts, but to have the experts enter separate contracts with you and bill you separately and directly for their services. We understand that the Association may have specific billing protocols and requirements as to documentation that must accompany our invoices, and we agree to conform to and abide by all reasonable protocols and related requirements.

We are sensitive to the cost of legal services and we understand that every client wishes to avoid unnecessary expenses. Accordingly, we will use our best efforts to ensure that our work for the Association is performed as efficiently and cost-effectively as possible.

Estimated Cost for This Representation

As we discussed, and as I stated above, the Firm and I will do everything possible to reach a negotiated resolution of all of the Association's issues with FPL, without having to resort to litigation. Pursuant to your request for a cost estimate in your email of October 3, 2024, I believe that our fees and costs to negotiate such a resolution, if both the Association

and FPL are able to agree on the terms thereof, should be in the range of \$20,000 to \$50,000. I would hope for a figure on the lower end of that range, but the potential costs involved may involve more meetings and more exchanges of draft agreements than I would hope, and thus I provide the higher figure as a reasonable estimate of our fees to reach a negotiated resolution. If litigation were to be required, the costs could be much more, because of the need for expert engineering and economic witnesses and the additional efforts on our part required to prosecute any such litigation. Of course, the Association will be free to direct us to cease work at any time, and we would provide an estimate of potential litigation costs if negotiations with FPL were to reach an impasse.

Conflict Identification Policy and Practices

Of course, our firm strictly adheres to the requirements of The Florida Bar regarding conflicts of interest. At this time, we have not identified any conflicts with our representation of the Bal Harbour Civic Association. Further, considering the specific subject matter of this engagement, we do not anticipate that we would encounter any conflicts of interest in the course of our representation concerning the Association's issues relating to obtaining and ensuring safe and reliable service from FPL at a reasonable cost.

Payment of Fees and Costs

No initial retainer payment is required for this representation. Invoices for fees and costs will be submitted to you monthly, shortly after the first of each month, and we expect payment within 30 days. If you have any problem with any bill at any time, please call me and we will resolve it.

Commencement of Representation

Our engagement with respect to this matter will commence upon your confirmation and acceptance of this engagement letter by signing in the space indicated below and returning one copy of this engagement letter to me. My signature below confirms the Firm's agreement to the engagement on the terms set forth above.

Thank you again for the opportunity to be of service. We look forward to working with you and the Civic Association on this matter.

Cordially yours,

GARDNER, BIST, BOWDEN, DEE, LaVIA,
WRIGHT, PERRY & HARPER, P.A.

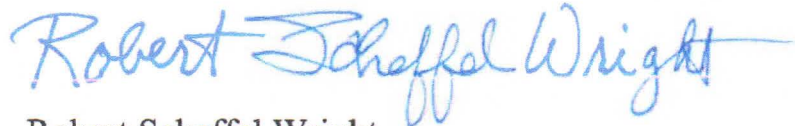

Robert Scheffel Wright
For the Firm

Engagement accepted and agreed to this 8th day of NOVEMBER 2024.

BAL HARBOUR CIVIC ASSOCIATION

By: Neen M Roga

Title: PRESIDENT,

**GARDNER, BIST, BOWDEN, DEE, LaVIA,
WRIGHT, PERRY & HARPER, P.A.**

**SCHEDULE OF 2024-2026 BILLING RATES FOR THE
BAL HARBOUR CIVIC ASSOCIATION**

<u>ATTORNEY/SERVICE PROVIDER</u>	<u>HOURLY RATE</u>
ROBERT SCHEFFEL WRIGHT	\$ 375
JOHN T. LAVIA, III	\$ 375
TIMOTHY J. PERRY	\$ 375
OTHER ATTORNEYS *	\$350-\$500

* **ONLY WITH SPECIFIC PRIOR AUTHORIZATION**

BAL HARBOUR

- V I L L A G E -

COUNCIL ITEM SUMMARY

Condensed Title:

**A RESOLUTION OF THE VILLAGE COUNCIL OF BAL HARBOUR VILLAGE, FLORIDA;
AMENDING THE FY 2024 OPERATING AND CAPITAL BUDGET.**

Issue:

Should Council approve the Resolution amending the FY 2024 Budget?

The Bal Harbour Experience:

- Beautiful Environment Safety Modernized Public Facilities/Infrastructure
 Destination & Amenities Unique & Elegant Resiliency & Sustainable Community
 Other: Organizational Priorities and Internal Infrastructure

Item Summary / Recommendation:

In accordance with Florida Statutes Section 166.241(4), the Village's final FY 2024 budget amendment should be adopted within 60 days following the end of the Fiscal Year. Budget amendments are required to adjust for unanticipated revenues and expenditures that have occurred since the adoption of the original budget.

THE ADMINISTRATION RECOMMENDS APPROVAL OF THIS RESOLUTION.

Advisory Board Recommendation:

N/A

Financial Information:

	Amount	Account	Account #
	\$500,000	Various	01-XX-5XXXXX
	\$255,000	Various	10-XX-5XXXXX

Sign off:

	Chief Financial Officer Claudia Dixon	Village Manager Jorge M. Gonzalez
--	---	---



BAL HARBOUR

- VILLAGE -

COUNCIL MEMORANDUM

TO: Honorable Mayor and Village Council

FROM: Jorge M. Gonzalez, Village Manager 

DATE: November 19, 2024

SUBJECT: **A RESOLUTION OF THE VILLAGE COUNCIL OF BAL HARBOUR VILLAGE, FLORIDA; AMENDING THE FY 2024 BUDGET BY REVISING THE 2024 FISCAL YEAR OPERATING AND CAPITAL BUDGET AS OUTLINED IN EXHIBIT "A" ATTACHED HERETO; AUTHORIZING THE VILLAGE MANAGER TO DO ALL THINGS NECESSARY TO CARRY OUT THE AIMS OF THIS RESOLUTION; AND PROVIDING FOR AN EFFECTIVE DATE.**

ADMINISTRATIVE RECOMMENDATION

It is recommended that the Council adopt the end of year budget amendment for Fiscal Year (FY) 2024 Operating and Capital Improvement Program Budget.

BACKGROUND

In accordance with Florida Statutes Section 166.241(4), the Village's final FY 2024 budget amendment should be adopted within 60 days following the end of the Fiscal Year. Budget amendments are required to adjust for unanticipated revenues and expenditures that have occurred since the adoption of the original budget.

The budget is the key fiscal document which determines how the Village obtains its resources and how it allocates them. It encapsulates most key decisions of consequence made by the organization, and is the expression of public policy priorities and legally authorizes the purposes for which public resources may be spent. Local governments must maintain an accounting system that assures that restricted resources are not inadvertently expended for inappropriate purposes. In practice, these requirements have led to a system of 'fund' accounting and reporting.

The Village has four primary funds, the General Fund, Tourism Fund, Security and Landscape Assessment Fund, and the Water & Sewer Fund. The General Fund is the Village's primary operating fund. It is used to account for the financial resources of the general government and operating departments except those required to be accounted for in another fund. The Tourism Fund, Security and Landscape Assessment Fund, and the Water & Sewer Fund, serve to isolate discrete revenue and expenditures for these specific purposes; they are proprietary in nature. The State Forfeiture Fund is restricted, the use of revenue within this fund must follow an approval process required by State Statute with subsequent approval by the Village Council.

The Village maintains budgetary controls to ensure compliance with legal provisions embodied in the annual appropriated budget that the Village Council approves. The level of budgetary control is established at the department level. Annual operating budgets are adopted for all Governmental Funds. Budgetary control for Capital Projects is achieved on a project-by-project basis when funding sources become available.

ANALYSIS

The following items are included in the final FY 2024 budget amendment Exhibit A:

General Fund (01)

Revenues (\$500,000 adjustment): Represents a conservative estimate of excess revenue received than anticipated to cover budget adjustments.

- Investment Interest Income Revenue: Increase of \$500,000 more investment interest revenue received than anticipated.

Expenditures (\$500,000 adjustment):

- Capital Construction: During FYE 2024, the Village non-Utility related capital programs had 3 active programs, which were the New Waterfront Park project, the Harbourfront Park - Jetty/Cutwalk construction project and the Village Hall project. \$100,000 Increase results from additional staffing needed to support the Village non-Utility related capital programs, including the grant function which is outsourced.
- Legal Support Services: \$400,000 related to legal and related defense costs incurred in connection with the two Bal Harbour Shops (BHS) cases and review of the Live Local Act application; as well the litigation with the contractor over the New Waterfront Park project. To date the Village has incurred approximately \$325,000 related to the two Bal Harbour Shops Live Local Act Litigation Cases; and \$100,000 related to the New Waterfront Park Litigation Case against the construction company, and related interaction with the architect over the defects. For the upcoming year, the Village has established a BHS Processing and Defense Fund. The costs associated with the two Shops cases to date, and any additional litigation or processing costs that may result in the future, will be covered by the BHS Processing and Defense Fund.

Resort Tax Fund (10)

Revenues (\$255,000 adjustment): Represents a conservative estimate of excess revenue received than anticipated to cover budget adjustments.

- Resort Tax Revenue: Increase of \$255,000 more resort tax revenue received than anticipated.

Expenditures (\$255,000 adjustment):

- Professional Services: \$235,000: During FYE 2024, Village Council approved a Resolution authorizing an agreement with EY in the amount of \$235,000 for the development of the Tourism Strategic Plan for Bal Harbour Village. This is a one-time cost to be paid for by Resort Tax Revenue.
- Law Enforcement Overtime Expenses: \$20,000: Overtime costs incurred for marine patrol section related activities.

This item is simply to adjust revenue and budget authority at the end of the FY. As a current year, FY 2025 mid-year budget amendment, I will bring forward for your approval a separate agenda item to carryforward the balance of the funds for ongoing projects or projects planned in FY 2024 which will be undertaken or completed during FY 2025. The mid-year amendment is consistent with best practices for municipal governance, and will provide for the allocation of funding for the completion of ongoing projects occurring in the current fiscal year. As in prior years, we anticipate having an operating surplus which has been programmed in the past to grow our reserves with a goal of maintaining one hundred percent of operating expenditures, the other half would be designated toward a capital reserve fund balance for future capital projects. Given the continued strong and stable financial position of the General Fund, this year and given the Village Council's recent endorsement of the five-year capital improvement program, I will again propose that we waive this policy by allocating the excess FY 2025 General Fund surplus at year end toward the Capital Projects Reserve.

THE BAL HARBOUR EXPERIENCE

Florida Statutes Section 166.241(4) requires final budget amendments to be adopted within 60 days following the end of the Fiscal Year.

CONCLUSION

The approval of the FY 2024 end of year budget amendment modifies the appropriation for the General Fund. This establishes a best practice which the Village will continue with the close-out of future fiscal years by formally amending the Budget appropriation by fund consistent with State Statute, for inclusion in the Village financial statements.

Attachments:

1. Exhibit A - Final Budget Amendment

RESOLUTION NO. 2024-__

A RESOLUTION OF THE VILLAGE COUNCIL OF BAL HARBOUR VILLAGE, FLORIDA; AMENDING THE FY 2024 BUDGET BY REVISING THE 2024 FISCAL YEAR OPERATING AND CAPITAL BUDGET AS OUTLINED IN EXHIBIT "A" ATTACHED HERETO; AUTHORIZING THE VILLAGE MANAGER TO DO ALL THINGS NECESSARY TO CARRY OUT THE AIMS OF THIS RESOLUTION; AND PROVIDING FOR AN EFFECTIVE DATE.

WHEREAS, upon the periodic review and analysis of current budgetary commitments and obligations, and based upon the projected needs and requirements of the Village and upon the recommendations of the Village Manager (and the concurrence of the Chief Financial Officer as to Accounting Principles); it is deemed necessary to adjust, amend and implement the FY 2024 Operating and Capital Budget as set forth in Exhibit "A" attached hereto and made a part hereof.

NOW, THEREFORE, BE IT RESOLVED BY THE VILLAGE COUNCIL OF BAL HARBOUR VILLAGE, FLORIDA, AS FOLLOWS:

Section 1. **Recitals Adopted.** That the above stated recitals are hereby adopted and confirmed.

Section 2. **Amendment Approved.** That the Village Council hereby approves the amendment of the FY 2024 Operating and Capital Improvement Program Budget as set forth on the attached Exhibit "A" which exhibit is deemed incorporated by reference as though set forth in full herein.

Section 3. **Manager Authorized.** That the Village Manager is hereby authorized to do all things necessary to carry out the aims of this Resolution.

Section 4. Effective Date. That this Resolution shall take effect immediately upon the adoption hereof. That this Resolution shall take effect immediately upon the adoption hereof and shall be applicable retroactively from and after October 1, 2023.

PASSED AND ADOPTED this 19th day of November, 2024.



Mayor Jeffrey P. Freimark

ATTEST:

Dwight S. Danie, Village Clerk

APPROVED AS TO FORM AND LEGAL SUFFICIENCY:

Village Attorney
Weiss Serota Helfman Cole & Bierman P.L.

BAL HARBOUR

- VILLAGE -

General Fund - Revenues and Expenditures Summary

	FY 2024 Adopted	FY 2024 Amended	FY 2024 Proposed Budget Amendments	FY 2024 Proposed Budget Amended
GENERAL FUND				
REVENUE:				
Ad Valorem Taxes	\$ 11,727,100	\$ 11,727,100	\$ -	\$ 11,727,100
Delinquent Ad Valorem Taxes	-	-	-	-
Utility Service Tax	999,800	999,800	-	999,800
Franchise Fee	853,400	853,400	-	853,400
Intergovernmental Revenue	939,300	939,300	-	939,300
Permits & Licenses	3,312,500	3,312,500	-	3,312,500
Fines & Forfeitures	935,000	935,000	-	935,000
Miscellaneous	1,245,100	1,315,000	500,000	1,815,000
Solid Waste Assessments	918,200	918,200	-	918,200
Subtotal Operating Revenue	20,930,400	21,000,300	500,000	21,500,300
Suntrust/Truist Rent	722,300	722,300	-	722,300
Grants - Capital Related	1,559,400	15,243,500	-	15,243,500
Appropriation of Fund Balance - Capital	573,500	6,516,200	-	6,516,200
Developer Contributions	3,900,000	3,900,000	-	3,900,000
Ad Valorem Taxes - BHS Processing & Defense Fund	-	-	-	-
TBD	-	-	-	-
TOTAL GENERAL FUND REVENUE	\$ 27,685,600	\$ 47,382,300	500,000	\$ 47,882,300
EXPENDITURES:				
LEGISLATIVE				
Salaries & Benefits	\$ 292,600	\$ 292,600	-	\$ 292,600
Other Operating	123,100	123,100	-	123,100
Operating Capital	-	-	-	-
TOTAL LEGISLATIVE	415,700	415,700	-	415,700
ADMINISTRATION				
Salaries & Benefits	1,497,900	1,497,900	-	1,497,900
Other Operating	136,900	136,900	-	136,900
Operating Capital	-	-	-	-
TOTAL ADMINISTRATION	1,634,800	1,634,800	-	1,634,800
FINANCE				
Salaries & Benefits	711,900	711,900	-	711,900
Other Operating	241,300	241,300	-	241,300
Operating Capital	-	-	-	-
TOTAL FINANCE	953,200	953,200	-	953,200
GENERAL GOVERNMENT				
Salaries & Benefits (Primarily Worker's Compensation)	146,600	146,600	-	146,600
Other Operating	1,694,600	1,694,600	-	1,694,600
Operating Capital	3,349,800	3,349,800	-	3,349,800
Non-Operating - BHS Processing & Defense Fund	-	-	-	-
TOTAL GENERAL GOVERNMENT	5,191,000	5,191,000	-	5,191,000
LAW ENFORCEMENT				
Salaries & Benefits	7,473,600	7,473,600	-	7,473,600
Other Operating	894,000	894,000	-	894,000
Operating Capital	560,000	975,800	-	975,800
TOTAL LAW ENFORCEMENT	8,927,600	9,343,400	-	9,343,400
BUILDING & PERMITTING				
Salaries & Benefits	1,793,000	1,793,000	-	1,793,000
Other Operating	415,100	415,100	-	415,100
Operating Capital	-	58,300	-	58,300
TOTAL BUILDING & PERMITTING	2,208,100	2,266,400	-	2,266,400

	FY 2024 Adopted	FY 2024 Amended	FY 2024 Proposed Budget Amendments	FY 2024 Proposed Budget Amended
PUBLIC WORKS & BEAUTIFICATION				
Salaries & Benefits	661,100	661,100	-	661,100
Other Operating	1,620,900	1,620,900	-	1,620,900
Operating Capital	2,263,000	6,487,600	-	6,487,600
TOTAL PUBLIC WORKS & BEAUTIFICATION	4,545,000	8,769,600	-	8,769,600
RECREATION, ARTS AND CULTURE				
Salaries & Benefits	642,600	642,600	-	642,600
Other Operating	770,100	770,100	-	770,100
Operating Capital	-	74,300	-	74,300
TOTAL RECREATION, ARTS AND CULTURE	1,412,700	1,487,000	-	1,487,000
INFORMATION TECHNOLOGY				
Salaries & Benefits	136,900	136,900	-	136,900
Other Operating	309,100	379,100	-	379,100
Operating Capital	93,500	99,700	-	99,700
TOTAL INFORMATION TECHNOLOGY	539,500	615,700	-	615,700
CAPITAL CONSTRUCTION				
Salaries & Benefits	386,000	386,000	-	386,000
Other Operating	30,000	30,000	100,000	130,000
Operating Capital (Capital Projects Only)	1,000,000	15,847,500	-	15,847,500
TOTAL CAPITAL CONSTRUCTION	1,416,000	16,263,500	100,000	16,363,500
LEGAL SUPPORT SERVICES (General Fund Only)				
Salaries & Benefits	-	-	-	-
Other Operating	442,000	442,000	400,000	842,000
Operating Capital	-	-	-	-
TOTAL LEGAL SUPPORT SERVICES	442,000	442,000	400,000	842,000
GENERAL FUND TOTAL - EXPENDITURES	\$ 27,685,600	\$ 47,382,300	\$ 500,000	\$ 47,882,300
ALL DEPARTMENTS EXPENDITURES				
Salaries & Benefits	\$ 13,742,200	\$ 13,742,200	\$ -	\$ 13,742,200
Other Operating	6,677,100	6,747,100	500,000	7,247,100
Operating Capital (Including Capital Projects)	7,266,300	26,893,000	-	26,893,000
Non-Operating - BHS Processing & Defense Fund	-	-	-	-
TOTAL ALL DEPARTMENTS EXPENDITURES	\$ 27,685,600	\$ 47,382,300	\$ 500,000	\$ 47,882,300

BAL HARBOUR

- V I L L A G E -

Resort Tax Fund - Revenues and Expenditures Summary

	FY 2024 Adopted	FY 2024- Amendment	FY 2024 Amended	FY 2024 Proposed Budget Amendments	FY 2024 Proposed Budget Amended
RESORT TAX FUND					
REVENUE:					
Operating Revenue	5,185,400	\$ -	\$ 5,185,400	\$ 255,000	\$ 5,440,400
Appropriation of Fund Balance/Carryover	245,000	4,356,700	4,601,700	-	4,601,700
TOTAL RESORT TAX REVENUE	\$ 5,430,400	\$ 4,356,700	\$ 9,787,100	\$ 255,000	\$ 10,042,100
EXPENDITURES - RESORT TAX ELIGIBLE FUNCTIONS:					
TOURISM & MARKETING					
Salaries & Benefits	\$ 394,000	\$ -	\$ 394,000	\$ -	\$ 394,000
Other Operating *	1,414,800	-	1,414,800	235,000	1,649,800
Operating Capital	150,000	69,500	219,500	-	219,500
TOTAL TOURISM & MARKETING	1,958,800	69,500	2,028,300	235,000	2,263,300
BEAUTIFICATION/GREENSPACE					
Salaries & Benefits	456,500	-	456,500	-	456,500
Other Operating	1,545,300	-	1,545,300	-	1,545,300
Operating Capital	-	37,200	37,200	-	37,200
TOTAL BEAUTIFICATION/GREENSPACE	2,001,800	37,200	2,039,000	-	2,039,000
LAW ENFORCEMENT					
Salaries & Benefits	338,200	-	338,200	20,000	358,200
Other Operating	9,800	-	9,800	-	9,800
Operating Capital	-	-	-	-	-
TOTAL LAW ENFORCEMENT	348,000	-	348,000	20,000	368,000
RECREATION, ARTS & CULTURE					
Salaries & Benefits	439,100	-	439,100	-	439,100
Other Operating *	682,700	-	682,700	-	682,700
TOTAL RECREATION, ARTS & CULTURE	1,121,800	-	1,121,800	-	1,121,800
CAPITAL PROGRAM					
Operating Capital	-	4,250,000	4,250,000	-	4,250,000
TOTAL CAPITAL PROGRAM	-	4,250,000	4,250,000	-	4,250,000
TOTAL RESORT TAX FUND - EXPENDITURES	\$ 5,430,400	\$ 4,356,700	\$ 9,787,100	\$ 255,000	\$ 10,042,100
(*) - Effective FYE 2023, Special Events is reflected under the Recreation, Arts & Culture Department. Prior year amounts are included under the Tourism and Marketing Department.					
ALL DEPARTMENTS EXPENDITURES					
Salaries & Benefits	\$ 1,627,800	\$ -	\$ 1,627,800	\$ 20,000	\$ 1,647,800
Other Operating	3,652,600	-	3,652,600	235,000	3,887,600
Operating Capital (Including Capital Projects)	150,000	4,356,700	4,506,700	-	4,506,700
TOTAL ALL DEPARTMENTS EXPENDITURES	\$ 5,430,400	\$ 4,356,700	\$ 9,787,100	\$ 255,000	\$ 10,042,100

BAL HARBOUR

- VILLAGE -

COUNCIL ITEM SUMMARY

Condensed Title:

A RESOLUTION OF THE VILLAGE COUNCIL OF BAL HARBOUR VILLAGE, FLORIDA; APPROVING THE VOLUNTARY CONTRIBUTION AGREEMENT REGARDING RIVAGE WITH CARLTON TERRACE OWNER, LLC.

Issue:

Should the Village Council approve the Voluntary Contribution Agreement proffered by Carlton Terrace Owner, LLC for the Rivage condominium?

The Bal Harbour Experience:

- | | | |
|---|--|---|
| <input checked="" type="checkbox"/> Beautiful Environment | <input checked="" type="checkbox"/> Safety | <input checked="" type="checkbox"/> Modernized Public Facilities/Infrastructure |
| <input checked="" type="checkbox"/> Destination & Amenities | <input type="checkbox"/> Unique & Elegant | <input checked="" type="checkbox"/> Resiliency & Sustainable Community |

Item Summary / Recommendation:

In 2022, the Village Architectural Review Board (ARB) approved, and the Village Council upheld, the ARB approval of the proposed redevelopment of the former Carlton Terrace condominium in the (OF) Oceanfront District (the "Rivage" condominium) by a development group led by The Related Group, known as Carlton Terrace Owner, LLC ("Owner"). Following an appeal to Village Council, which upheld the grant of the Certificate of Appropriateness ("COA"), and three separate challenges by the neighboring Bellini Condominium Association, Inc., all litigation has been resolved in favor of the approval of the COA or voluntarily dismissed with prejudice. The Rivage is nearing issuance of its principal building permit, and the Owner desires to proffer a Voluntary Contribution Agreement to implement the conditions of the ARB approval and enhance the proffered contribution in light of the increased scope of the jetty improvement, which is located close to and benefits the Rivage as well as all of the Village residents and visitors.

THE ADMINISTRATION RECOMMENDS THE APPROVAL OF THIS RESOLUTION.

Financial Information:

Amount	Account	Account #
X	X	X

Sign off:

Director Building Department	Chief Financial Officer	Village Manager
Eliezer Palacio	Claudia Dixon	Jorge M. Gonzalez

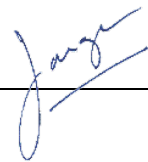

BAL HARBOUR

- V I L L A G E -

COUNCIL MEMORANDUM

TO: Honorable Mayor and Village Council

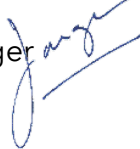
FROM: Jorge M. Gonzalez, Village Manager 

DATE: November 19, 2024

SUBJECT: **A RESOLUTION OF BAL HARBOUR VILLAGE, FLORIDA; APPROVING THE VOLUNTARY CONTRIBUTION AGREEMENT REGARDING RIVAGE WITH CARLTON TERRACE OWNER, LLC; PROVIDING FOR IMPLEMENTATION; PROVIDING FOR AN EFFECTIVE DATE.**

ADMINISTRATIVE RECOMMENDATION

I am recommending approval of this Resolution.

BACKGROUND

In 2022, the Village Architectural Review Board (ARB) approved, and the Village Council upheld, the ARB approval of the proposed redevelopment of the Carlton Terrace condominium in the (OF) Oceanfront District (the "Rivage") by a development group led by The Related Group, known as Carlton Terrace Owner, LLC ("Owner"). Following an appeal to Village Council, which upheld the grant of the Certificate of Appropriateness ("COA"), and three (3) separate challenges by the neighboring Bellini Condominium Association, Inc., all litigation has been resolved in favor of the approval of the COA or voluntarily dismissed with prejudice. The Rivage is nearing issuance of its principal building permit, and it is therefore time to address implementation of the conditions of the ARB approval.

The Rivage has proffered a Voluntary Contribution Agreement to implement Condition 20 of the Certificate of Appropriateness, which states:

20. The Applicant voluntarily proffers as a public benefit to the Village, a donation to the Village of \$2,000,000.00 to be used toward the funding of the Village Jetty improvement, to be applied in the sole discretion of the Village towards any expense related to that improvement, including but not limited to the installation of artwork on the new jetty if the Village so desires. The voluntary donation shall be made in two installments:

- a. \$1,000,000 prior to the issuance of the full master permit for the project (this shall not preclude the issuance of demolition, site work and foundation permits prior to that time); and
- b. \$1,000,000 prior to the issuance of the Temporary Certificate of Occupancy for floors that contain at least twelve dwelling units for the main building of the Project.

The Applicant shall work with the Village and its manager and attorney on any documentation or approvals necessary or desirable for the Village's acceptance of the voluntary donation to the Village Jetty improvement.

Following approval of the COA and application for the master building permit, the Owner learned that the cost and scope of the program for the Jetty Improvement has been expanded by the Village to include additional improvements (the "Updated Jetty Improvement"). Because the Updated Jetty Improvement will further benefit the Rivage, its residents and the Village residents generally, the Owner now wishes to increase the Voluntary Contribution to \$3,000,000.00 in recognition of the increased program and expense of the Updated Jetty Improvement. Rivage will pay \$2,000,000.00 in the first installment and \$1,000,000.00 in the second installment.

THE BAL HARBOUR EXPERIENCE

By approving this Agreement, the Village would continue to "implement smart policies and strategic solutions to address the challenges of today and to ensure that we remain a Resilient and Sustainable community able to protect our future."

CONCLUSION

It is recommended that the Village Council adopt the proposed Resolution approving the Agreement.

Attachments:

1. Voluntary Contribution Agreement

RESOLUTION NO. 2024-____

A RESOLUTION OF THE VILLAGE COUNCIL OF BAL HARBOUR VILLAGE, FLORIDA; APPROVING THE VOLUNTARY CONTRIBUTION AGREEMENT REGARDING RIVAGE WITH CARLTON TERRACE OWNER, LLC; PROVIDING FOR IMPLEMENTATION; PROVIDING FOR AN EFFECTIVE DATE.

WHEREAS, in 2022, the Village Architectural Review Board approved, and the Village Council upheld, the ARB approval of the proposed redevelopment of the Carlton Terrace condominium in the OF Oceanfront District (the "Rivage" condominium) by a development group led by Related, known as Carlton Terrace Owner, LLC ("Owner"); and

WHEREAS, following an appeal to Village Council, which upheld the grant of the Certificate of Appropriateness ("COA"), and three separate challenges by the neighboring Bellini Condominium Association, Inc., all litigation has been resolved in favor of the approval of the COA or voluntarily dismissed with prejudice; and

WHEREAS, the Rivage is nearing issuance of its principal building permit, and the Owner desires to proffer a Voluntary Contribution Agreement to implement the conditions of the ARB approval and enhance the proffered contribution in light of the increased scope of the jetty improvement, which is located close to and benefits the Rivage as well as all of the Village residents and visitors; and

WHEREAS, the Village Council finds that this Resolution is in the best interest and welfare of the residents of the Village.

NOW, THEREFORE, BE IT RESOLVED BY THE VILLAGE COUNCIL OF BAL HARBOUR VILLAGE, FLORIDA, AS FOLLOWS:

Section 1. Recitals Adopted. That the above stated recitals are hereby adopted and confirmed.

Section 2. Approval of the Agreement. That the Voluntary Contribution Agreement between the Owner and Bal Harbour Village, Florida, attached as Exhibit "A," together with such non-material changes as may be acceptable to the Village Manager and approved as to form and legality by the Village Attorney, is approved.

Section 3. Implementation. That the Village Manager and Village Attorney are

authorized to take all actions necessary to implement the terms and conditions of the Voluntary Contribution Agreement.

Section 4. Effective Date. That this Resolution shall take effect immediately upon the adoption hereof.

PASSED AND ADOPTED this 19th day of November, 2024.



Mayor Jeffrey P. Freimark

ATTEST:

Dwight S. Danie, Village Clerk

APPROVED AS TO FORM AND LEGAL SUFFICIENCY:

Village Attorney
Weiss Serota Helfman Cole & Bierman P.L.

VOLUNTARY CONTRIBUTION AGREEMENT

This Voluntary Contribution Agreement (“Agreement”) is made this ___ day of _____, 2024, between Carlton Terrace Owner, LLC, a Delaware limited liability company (the “Owner”) and Bal Harbour Village, Florida (the “Village”), a municipal corporation.

RECITALS

WHEREAS, the Owner is the fee simple owner of the property in Miami-Dade County, Florida, legally described on Exhibit “A”, having a street address of 10245 Collins Avenue, Bal Harbour, Florida (the “Property”); and

WHEREAS, on October 6, 2022, the Architectural Review Board (“ARB”) unanimously approved a Certificate of Appropriateness for the development of the Rivage, Bal Harbour on the Property, based upon the plans presented to the ARB as part of Application. The project is a 24-story mixed use ultra-luxury condominium project containing up to 61 residential units, a medical office and various luxury accessory uses, for residents and guests only, including but not limited to: cabanas, card and social rooms, a gym and spa facilities, a private dining room, pools, sports courts, gardens, and beachfront amenities and food and beverage services (the “Project”). The ARB Certificate of Appropriateness 2022-1006 was rendered on October 10, 2022 (“the Certificate”); and

WHEREAS, on October 25, 2022 the Village Council heard the Appeal of the ARB approval of the Certificate, filed by the Bellini Condominium Association (the “Bellini”) and, by Resolution 2022-1503 filed of record, on October 31, 2022 the Village Council unanimously affirmed the decision of the ARB; and

WHEREAS, subsequent to the Village Council affirmation, on November 30, 2022 the Bellini filed a petition for a Writ of Certiorari challenging Village Council affirmation of the Certificate as issued by the ARB on numerous grounds, including but not limited to: denial of due process, its mixed use character, the inclusion of the medical office, the validity of the ARB composition and membership, construction seaward of the coastal construction control line, and a claim of contract zoning due to a voluntary contribution to the Village toward the jetty renovation project, which is highly visible from the Property and the two properties north of the Property; and

WHEREAS, on June 27, 2023 after briefing and oral argument before a three-judge panel, the Circuit Court Appellate Division issued its Opinion denying the Bellini petition addressing each of the Bellini arguments and finding no merit to any of the arguments raised by the Bellini. The Circuit Court opinion became final and binding on July 27, 2023; and

WHEREAS, prior to the time of the ARB hearing and review of the Certificate, the Owner learned of a Village plan to renovate and beautify the south Haulover jetty to transform it from a more or less utilitarian, but very important protective structure, into a true community asset with recreational, aesthetic and artistic improvements (the “Jetty Improvement ”); and

WHEREAS, as a major property owner in the Village located in close proximity to the Jetty Improvement, which will be in clear view of the Property and will benefit the future residents of the Project in addition to the Village Residents generally, the Owner offered to voluntarily contribute to the Jetty Improvement to help ensure its success (the “Voluntary Contribution”); and

WHEREAS, the Owner’s offer to make the Voluntary Contribution was reduced to writing in the form of Condition 20 of the Certificate as follows:

20. The Applicant voluntarily proffers as a public benefit to the Village, a donation to the Village of \$2,000,000.00 to be used toward the funding of the Village Jetty improvement, to be applied in the sole discretion of the Village towards any expense related to that improvement, including but not limited to the installation of artwork on the new jetty if the Village so desires. The voluntary donation shall be made in two installments:

- a. \$1,000,000 prior to the issuance of the full master permit for the project (this shall not preclude the issuance of demolition, site work and foundation permits prior to that time); and
- b. \$1,000,000 prior to the issuance of the Temporary Certificate of Occupancy for floors that contain at least twelve dwelling units for the main building of the Project.

The Applicant shall work with the Village and its manager and attorney on any documentation or approvals necessary or desirable for the Village’s acceptance of the voluntary donation to the Village Jetty improvement.

; and

WHEREAS, the Bellini challenged this condition as being contract zoning, but the Circuit Court in its opinion determined that argument was without merit; and

WHEREAS, on or about July 17, 2023 the Owner applied for the master building permit for the Project pursuant to the Certificate, paid all required processing fees and was issued building permit process number BON-23-07-001. The Owner and design and construction team have been working with the Village building and other departments and the numerous reviewing agencies and trades responding to comments and making revisions as required by the Village and other reviewers. On or about September 13, 2024, the Village Building department informed the Owner and design team that the Master Building Permit Plans for the Project have been approved as being substantially in compliance with the Certificate, the Village Code and the Florida Building Code and other applicable codes, and the permit is ready to be issued upon payment of the balance of the permit and other fees along with the first installment of the Voluntary Contribution; and

WHEREAS, subsequent to the application for the master building permit, the Owner has learned that the cost and scope of the program for the Jetty Improvement has been expanded to include other improvements (the “Updated Jetty Improvement”); and

WHEREAS, because the Updated Jetty Improvement will further benefit the Property, the Project, its residents and the Village residents generally, the Owner now wishes to increase the

Voluntary Contribution in recognition of the increased program and expense of the Updated Jetty Improvement.

TERMS

NOW THEREFORE, for and in consideration of the mutual covenants contained herein, it is hereby understood and agreed:

1. **Recitals Adopted.** The above stated recitals are true and correct and are hereby adopted and confirmed.
2. The Village acknowledges and agrees that it and its various departments, along with numerous other County and state departments not controlled by the Village, have reviewed the Master Building Permit Plans for the Project, as described in Exhibit "B", and determined that the plans are substantially in compliance with the Certificate, the Village Code, and the Florida Building Code and other applicable codes such that the Master Building permit will be issued upon payment of all applicable fees and payment of the first installment of the Voluntary Contribution.
3. The Owner desires to increase its Voluntary Contribution to help implement the Updated Jetty Improvement and the Village wishes to accept such increased contribution. Therefore the Voluntary Contribution shall be increased to \$3,000,000 and the first installment shall be increased to \$2,000,000, to otherwise be made in accordance with Condition 20 of the Certificate.
4. **Severability.** Invalidation of any of these covenants, by judgment of court in any action initiated by a third party, in no way shall affect any of the other provisions of this Agreement, which shall remain in full force and effect.
5. **Successor(s), Assigns, and Designees.** The covenants and obligations set forth in this Agreement shall extend to the Owner, its successor(s) and/or assigns. Nothing contained herein shall be deemed to be a dedication, conveyance or grant to the public in general nor to any persons or entities except as expressly set forth herein.
6. **Construction of Agreement.** The provisions of this Agreement shall be strictly construed against the Owner. In construing this Agreement, the singular shall be held to include the plural, the plural shall be held to include the singular, and reference to any particular gender shall be held to include every other and all genders.

[Execution blocks on following pages]

IN WITNESS WHEREOF, these presents have been executed this 11th day of November, 2024.

Carlton Terrace Owner, LLC,
a Delaware limited liability company

[Signature]

Print Name Elvia Arquez

[Signature]

Print Name Eric Ferdin

[Signature]

By: Ben Coerber

Its: VP

STATE OF Florida)
) SS
COUNTY OF Miami-Dade)

The foregoing instrument was acknowledged before me this 11th day of November, 2024 by Ben Coerber, the VP, Carlton Terrace Owner, LLC, a Delaware Limited Liability Company who is () personally known to me or () produced a valid driver's license as identification.

Notary Public: [Signature] HH 310549
Sign Name: [Signature]
Print Name: Jessica Viaros

My Commission Expires:
10/18/2026

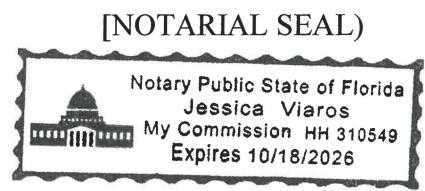

ACKNOWLEDGMENT AND ACCEPTANCE
BY BAL HARBOUR VILLAGE

KNOW ALL MEN BY THESE PRESENTS that:

Bal Harbour Village acknowledges and accepts the foregoing Voluntary Contribution Agreement and each and all of the terms and provisions contained therein.

DATED this ____ day of _____ 2024.

BAL HARBOUR VILLAGE

By: _____
VILLAGE MANAGER

ATTEST:

VILLAGE CLERK

EXHIBIT "A"

LEGAL DESCRIPTION

Lot 16, Ocean Front Section Of Bay Harbor, according to the plat thereof, as recorded in Plat Book 44, Page 27, of the Public Records of Miami-Dade County, Florida, and that area between the Easterly line of Lot 16 as shown on the aforementioned plat and the Erosion Control Line Easterly thereof; bordered on the North by the Northerly line of said Lot 16 extended Easterly to the Erosion Control Line; bordered on the South by the Southerly line of said Lot 16 extended Easterly to the Erosion Control Line.

EXHIBIT "B"

Approved Master Permit Plans

Architectural Plans by Cohen, Freedman, Encinosa & Associates entitled The Residences of Bal Harbour, inclusive of the following sheets:

<u>Drawing No.</u>	<u>Title</u>	<u>Digitally Signed</u>
A0-005	SURVEY	9/12/2024
A0-006	SITE / DATA	9/12/2024
A0-008	GROUND LEVEL - SITE	9/12/2024
A0-013	GARAGE BASEMENT PARKING 1ST LEVEL	9/9/2024
A0-014	GARAGE BASEMENT PARKING 2ND LEVEL	9/9/2024
A0-016	GARAGE BASEMENT 1ST LEVEL - PARTIAL 2	9/9/2024
A0-018	GARAGE BASEMENT 2ND LEVEL - PARTIAL 2	9/9/2024
A1-100	GROUND LEVEL - CABANAS	9/9/2024
A1-101	GROUND LEVEL - TOWER FLOOR PLAN	9/9/2024

BAL HARBOUR

- V I L L A G E -

COUNCIL ITEM SUMMARY

Condensed Title:

A RESOLUTION OF THE VILLAGE COUNCIL OF BAL HARBOUR VILLAGE, FLORIDA, RATIFYING THE EXECUTION OF THE GRANT AGREEMENT WITH THE FLORIDA INLAND NAVIGATION DISTRICT (FIND) FOR THE HARBOURFRONT PARK PHASE III STRUCTURAL PROJECT (SEGMENT B) IN THE AMOUNT OF THREE MILLION DOLLARS (\$3,000,000); AUTHORIZING THE VILLAGE MANAGER TO IMPLEMENT THE TERMS AND CONDITIONS OF THE AGREEMENT.

Issue:

Should the Village Council ratify the execution of the FIND Waterways Assistance Program grant agreement?

The Bal Harbour Experience:

- | | | |
|---|--|---|
| <input checked="" type="checkbox"/> Beautiful Environment | <input checked="" type="checkbox"/> Safety | <input checked="" type="checkbox"/> Modernized Public Facilities/Infrastructure |
| <input checked="" type="checkbox"/> Destination & Amenities | <input checked="" type="checkbox"/> Exclusivity & Access | <input checked="" type="checkbox"/> Resiliency & Sustainable Community |

Item Summary / Recommendation:

The Village Council is asked to ratify the execution of a grant agreement with the Florida Inland Navigation District (FIND) under the Waterways Assistance Program. This grant provides \$3,000,000 in funding for Segment B of the Harbourfront Park project, an expansive and complex coastal revetment and seawall structure that extends from the jetty bulkhead to the tip of the hook-shaped curve. This portion of the project, which requires significant structural improvements, is critical for enhancing coastal resiliency, protecting against erosion, and providing community access to the waterfront. The FIND grant represents the largest award in Miami-Dade County and the third-largest statewide.

With the grant agreement fully executed on October 28, 2024, this Resolution also authorizes the Village Manager and/or designee to manage all aspects of the grant's implementation, including compliance with funding requirements, reporting obligations, and expenditure of grant funds as specified. The funding will support key structural elements, including reinforced concrete, rip rap, and a living shoreline to support marine habitats. Approval of this Resolution ensures that Bal Harbour Village has the necessary resources and authority to move forward with this landmark project.

THE ADMINISTRATION RECOMMENDS THE APPROVAL OF THIS RESOLUTION.

Financial Information:

Amount	Account	Account #
X	X	X

Sign off:

Capital Program Director Matilde E. Reyes	Chief Financial Officer Claudia Dixon	Village Manager Jorge M. Gonzalez
---	---	---

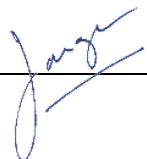

BAL HARBOUR

- V I L L A G E -

COUNCIL MEMORANDUM

TO: Honorable Mayor and Village Council

FROM: Jorge M. Gonzalez, Village Manager 

DATE: November 19, 2024

SUBJECT: **A RESOLUTION OF THE VILLAGE COUNCIL OF BAL HARBOUR VILLAGE, FLORIDA, RATIFYING THE EXECUTION OF THE GRANT AGREEMENT WITH THE FLORIDA INLAND NAVIGATION DISTRICT (FIND) FOR THE HARBOURFRONT PARK PHASE III STRUCTURAL PROJECT (SEGMENT B) IN THE AMOUNT OF THREE MILLION DOLLARS (\$3,000,000); AUTHORIZING THE VILLAGE MANAGER TO IMPLEMENT THE TERMS AND CONDITIONS OF THE AGREEMENT; PROVIDING FOR IMPLEMENTATION; PROVIDING FOR AN EFFECTIVE DATE.**

ADMINISTRATIVE RECOMMENDATION

I am recommending approval of this Resolution.

BACKGROUND

On April 9, 2024, the Village Council approved Resolution No. 2024-1631, which authorized the submission of a grant application to the Florida Inland Navigation District (FIND) under its Waterways Assistance Program (WAP) for Phase III of the Harbourfront Park project. This phase focuses on Segment B, which requires structural marine-related improvements. This area not only enhances community access to coastal amenities but also serves as a critical barrier against coastal erosion, sea-level rise and flooding.

In September 2024, at FIND's Final Tax Hearing, the Board approved grant funding allocations for the 2024-2025 cycle, with awards effective as of October 1, 2024. Out of 70 statewide applications, 54 projects were awarded funding, with Bal Harbour Village receiving the highest grant award in Miami-Dade County and the third-largest award statewide. The Village's \$3,000,000 award represents a significant endorsement of the project's value in enhancing regional resilience and community access.

In October 2024, the Village received the draft grant agreement from FIND. The FIND grant agreement (Agreement No. DA-BHV-24-293), attached as Exhibit A, was fully executed by FIND and the Village on October 28, 2024. The agreement specifies an end date of September 30, 2026, with an option for a one-year extension through September 30, 2027.

ANALYSIS

Segment B of the Harbourfront Park project is an expansive and complex coastal revetment and seawall structure extending from the jetty bulkhead to the tip of the hook-shaped curve. This segment represents one of the most technically challenging portions of the entire project, demanding sophisticated engineering and an intricate construction approach. The structural designs for Segment B are currently being revised by the subconsultant Moffatt & Nichol, working under Charles Benson Architects, the newly appointed Architect of Record. This structural engineering process is critical to ensuring that the revetment and seawall can withstand the demanding coastal environment.

Segment B's design includes reinforced concrete, rip rap, stem walls, lateral walls, and a concrete cap, creating a resilient infrastructure that not only fortifies the coastline but also enhances ecological sustainability. A task order will soon be issued to Cummins Cederberg to provide additional services specific to Segment B, including the integration of a living shoreline component. This living shoreline will support the relocation of essential coral and grasses, preserving critical marine habitats affected by construction activities.

To manage this unprecedented project, Bal Harbour Village has engaged a Construction Manager at Risk (CMAR), Whiting-Turner Company, along with their specialized subconsultant, Ebsary Foundation. The collaboration of these industry leaders, along with the Village's own project management team, reflects the extensive expertise and resources required to realize this ambitious structure.

This project sets a groundbreaking precedent, demonstrating what coastal infrastructure can achieve in terms of both resilience and ecological integration. The Village is navigating uncharted territory by constructing a multi-functional coastal structure unlike any other globally. This innovative approach not only meets the Village's coastal protection needs but also sets a new standard for integrating structural resilience with environmental stewardship.

Through the approval of this Resolution, the Village will formally ratify the FIND grant agreement, ensuring that the necessary funding, oversight, and compliance mechanisms are in place to complete this historic project. This Resolution empowers the Village Manager, or his designee, to coordinate these efforts, driving forward a project that redefines what is possible in coastal infrastructure and environmental integration.

THE BAL HARBOUR EXPERIENCE

The Segment B revetment and seawall structure exemplifies the Village's commitment to the Bal Harbour Experience by blending resilient infrastructure with environmental stewardship and coastal beauty. This section of the Harbourfront Park not only protects our shoreline but also offers an engaging and accessible waterfront for residents and visitors

alike. Integrating a living shoreline to preserve coral and marine grasses aligns with our dedication to sustainability, while the innovative design sets a global standard for coastal infrastructure. This project reflects the Village's core values: resilience, exclusivity, natural beauty, and a forward-thinking approach to public spaces that enhance both community and environmental well-being.

CONCLUSION

The Village's ambitious Harbourfront Park project, particularly the expansive and complex Segment B, reflects a commitment to advancing coastal resilience, environmental preservation, and enhanced public accessibility. By ratifying the FIND grant agreement, this Resolution secures essential funding to support Segment B's extensive structural and ecological components, establishing it as a landmark project in coastal infrastructure. This project sets new standards in shoreline protection, involving collaboration with industry leaders and an innovative design that integrates a living shoreline. Approval of this Resolution authorizes the Village Manager and/or designee to move forward with implementing and overseeing these efforts, ensuring that Bal Harbour remains at the forefront of resilient, sustainable, and beautiful coastal environments that protect our community and natural assets for generations to come.

Attachments:

1. Exhibit A - FIND Waterway Assistance Program Grant Agreement - DA-BHV-24-293

RESOLUTION NO. 2024-____

A RESOLUTION OF THE VILLAGE COUNCIL OF BAL HARBOUR VILLAGE, FLORIDA, RATIFYING THE EXECUTION OF THE GRANT AGREEMENT WITH THE FLORIDA INLAND NAVIGATION DISTRICT (FIND) FOR THE HARBOURFRONT PARK PHASE III STRUCTURAL PROJECT (SEGMENT B) IN THE AMOUNT OF THREE MILLION DOLLARS (\$3,000,000); AUTHORIZING THE VILLAGE MANAGER TO IMPLEMENT THE TERMS AND CONDITIONS OF THE AGREEMENT; PROVIDING FOR IMPLEMENTATION; PROVIDING FOR AN EFFECTIVE DATE.

WHEREAS, on April 9, 2024, the Village Council approved Resolution No. 2024-1631, authorizing the submission of a grant application to the Florida Inland Navigation District (FIND) for Phase III of the Harbourfront Park Project, specifically for Segment B structural improvements; and

WHEREAS, Segment B of the Harbourfront Park Project is a critical coastal revetment and seawall structure that provides resilience against coastal erosion, sea-level rise, and flooding while enhancing public access to the waterfront; and

WHEREAS, FIND's Board of Commissioners approved the Village's grant application, awarding Bal Harbour Village the sum of three million dollars (\$3,000,000) as part of the 2024-2025 Waterways Assistance Program, representing the largest award in Miami-Dade County and the third-largest statewide; and

WHEREAS, the Village received and executed the FIND grant agreement (Agreement No. DA-BHV-24-293) on October 28, 2024, attached hereto as Exhibit "A," which provides funding through September 30, 2026, with an option for a one-year extension through September 30, 2027; and

WHEREAS, the Village Council desires to ratify the execution of the grant agreement and authorize the Village Manager and/or designee to implement all terms and conditions required by the grant, including compliance with reporting and funding requirements.

NOW, THEREFORE, BE IT RESOLVED BY THE VILLAGE COUNCIL OF BAL HARBOUR VILLAGE, FLORIDA, AS FOLLOWS:

Section 1. Recitals Adopted. That the above recitals are hereby adopted and confirmed as true and correct and are incorporated herein by this reference.

Section 2. Ratification of Grant Agreement. The Village Council hereby ratifies the execution of the Florida Inland Navigation District (FIND) Grant Agreement No. DA-BHV-24-293, attached hereto as Exhibit "A," for the Harbourfront Park Phase III Structural Project (Segment B) in the amount of three million dollars (\$3,000,000).

Section 3. Expenditures Approved. The Village Council hereby approves the expenditure of funds as specified in the grant agreement, authorizing the Village Manager and/or designee to receive and expend grant funds in accordance with the agreement's terms and for the purposes outlined therein.

Section 4. Implementation. The Village Council hereby authorizes the Village Manager and/or designee to take all necessary actions to implement the terms and conditions of the grant agreement, including coordinating with FIND, ensuring compliance with all funding requirements, managing reporting obligations, and executing any further documents, agreements, or amendments related to this grant, provided that such actions do not impose any additional fiscal impact on the Village.

Section 5. Effective Date. That this Resolution shall take effect immediately upon the adoption hereof.

PASSED AND ADOPTED this 19th day of November, 2024.



Mayor Jeffrey P. Freimark

ATTEST:

Dwight S. Danie, Village Clerk

APPROVED AS TO FORM AND LEGAL SUFFICIENCY:

Village Attorney
Weiss Serota Helfman Cole & Bierman P.L.

**FLORIDA INLAND NAVIGATION DISTRICT
PROJECT AGREEMENT**

PROJECT NO. DA-BHV-24-293

This PROJECT AGREEMENT ("AGREEMENT") made and entered into this 28th day of October, 2024 by and between the Florida Inland Navigation District (hereinafter the "DISTRICT"), and the Bal Harbour Village, (hereinafter the "PROJECT SPONSOR").

In consideration of the mutual promises and covenants contained herein, the parties agree as follows:

1. **PROJECT** - Subject to the provisions of this AGREEMENT and Rule 66B-2 of the Florida Administrative Code (a current copy of which is attached as Exhibit "B"), the DISTRICT has approved assistance funding to the PROJECT SPONSOR in furtherance of an approved project ("PROJECT") consisting of the Village Jetty and Cutwalk Segment B. Said PROJECT is more specifically described in the PROJECT SPONSOR'S Waterways Assistance Application, which is on file at the DISTRICT's headquarters.

Any modifications to the PROJECT'S scope of work shall require written advance notice and justification from the PROJECT SPONSOR and the prior written approval of the DISTRICT.

2. **TERM** - The PROJECT SPONSOR shall not commence work on the PROJECT prior to the execution of this AGREEMENT unless specifically authorized by the DISTRICT Board and **shall complete the PROJECT and submit all required payment reimbursement information on or before September 30, 2026 ("PROJECT PERIOD")**, unless the PROJECT PERIOD has been extended with the prior written approval of the DISTRICT. Any request for an extension of the PROJECT PERIOD shall require submittal by the PROJECT SPONSOR of a request for extension to the DISTRICT no later than 60 days prior to the original expiration date of the PROJECT PERIOD. This request will then be considered by the DISTRICT Board, whose decision shall be final. In no event other than a declared state of emergency that affects the project completion shall the PROJECT be extended beyond September 30, 2027. The PROJECT SPONSOR acknowledges this is the only provision to carry over the DISTRICT assistance funding under this AGREEMENT beyond September 30, 2026, and that any extension of funding beyond this date shall be at the sole discretion of the DISTRICT.

3. **ASSISTANCE AMOUNT** - The DISTRICT shall contribute ("ASSISTANCE AMOUNT") no more than twenty-seven percent (27%) ("MATCHING PERCENTAGE") of the PROJECT SPONSOR'S eligible out-of-pocket costs for completion of this PROJECT ("PROJECT AMOUNT"). Payment of funds by the DISTRICT to the PROJECT SPONSOR (the "ASSISTANCE AMOUNT") will be on a reimbursement basis only, and only for those authorized out of pocket costs as shown in Exhibit A, Project Cost Estimate ("PROJECT COSTS") and meeting the requirements of Section 5 below and shall not, in any event, exceed \$3,000,000.00.

Any modifications to the PROJECT's Cost Estimate (Exhibit A) shall require written advance notice and justification from the PROJECT SPONSOR and the prior written approval of the DISTRICT.

4. **MATCHING FUNDS** - The PROJECT SPONSOR warrants and represents that it has the PROJECT SPONSOR Match Amount (the PROJECT AMOUNT less the ASSISTANCE AMOUNT) available for the completion of the PROJECT and shall, prior to the execution of this AGREEMENT, have provided the DISTRICT with suitable evidence of the availability of such funds using the DISTRICT's Form #95-01 (Exhibit C, Matching Funds Certification) and, upon request, providing the DISTRICT with access to applicable books and records, financial statements, and bank statements.

5. **PROJECT COSTS** - To be eligible for reimbursement under this AGREEMENT, PROJECT COSTS must be necessary and reasonable for the effective and efficient accomplishment of the PROJECT and must be directly allocable thereto. PROJECT COSTS are generally described in Exhibit B, Chapter 66B-2, F.A.C.. PROJECT COSTS must be incurred, and work performed within the PROJECT PERIOD, with the exception of pre-AGREEMENT costs, if any, consistent with Section 6 below, which are also eligible for reimbursement by the DISTRICT.

If the PROJECT SPONSOR receives additional funding for the PROJECT COSTS from another source that was not identified in the original application and that changes the AGREEMENT MATCHING PERCENTAGE, the PROJECT SPONSOR shall proportionately reimburse the DISTRICT's program funds equal to the MATCHING PERCENTAGE in this AGREEMENT. The PROJECT SPONSOR shall promptly notify the DISTRICT of any project payments it receives from a source other than the DISTRICT.

6. **PRE-AGREEMENT COSTS** - The DISTRICT and the PROJECT SPONSOR fully understand and agree that there shall be no reimbursement of funds by the DISTRICT for any

obligation or expenditure made prior to the execution of this AGREEMENT unless previously delineated in Exhibit A, consistent with Exhibit B, and previously approved by the DISTRICT Board during the grant review process.

7. **REIMBURSEMENT PROCEDURES** - PROJECT COSTS shall be reported to the DISTRICT and summarized on the Payment Reimbursement Request Form (Form #90-14) attached as Exhibit D. Supporting documentation including bills and canceled payment vouchers for expenditures shall be provided to the DISTRICT by the PROJECT SPONSOR or LIAISON AGENT with any payment request. All records in support of the PROJECT COSTS included in payment requests shall be subject to review and approval by the DISTRICT or by an auditor selected by the DISTRICT. Audit expenses shall be borne by the PROJECT SPONSOR.

Project funds may be released in installments, at the discretion of the DISTRICT, upon submittal of a payment request by the PROJECT SPONSOR or LIAISON AGENT. The DISTRICT shall retain ten percent (10%) of each installment payment until the completion of the PROJECT.

The following costs, if authorized in the attached Exhibit B, shall be reimbursed only upon completion of the PROJECT to the reasonable satisfaction of the DISTRICT and in accordance with Exhibit B: personnel, equipment, project management, administration, inspection, and design, permitting, planning, engineering, and/or surveying costs. Assuming the PROJECT SPONSOR has otherwise fully complied with the requirements of this AGREEMENT, reimbursement for a PROJECT approved as Phase I project will be made only upon commencement of construction of the PROJECT for which the Phase I planning, designing, engineering and/or permitting were directed, which may or may not involve further DISTRICT funding. Procedures set forth below with respect to reimbursement by the DISTRICT are subject to this requirement of commencement of construction.

The DISTRICT shall have the right to withhold any payment hereunder, either in whole or part, for non-compliance with the terms of this AGREEMENT.

8. **FINAL REIMBURSEMENT** - The PROJECT SPONSOR, upon completion of the PROJECT, shall submit to the DISTRICT a request for final reimbursement of the ASSISTANCE AMOUNT less any prior installment payments. The payment amounts previously retained by the DISTRICT shall be paid upon (1) receipt of the Final Audit report of expenses incurred on the PROJECT by the DISTRICT, (2) full completion of the PROJECT to the reasonable satisfaction of the DISTRICT, (3) submission of Project Completion Certification Form No. 90-13 (Exhibit E), (4) submission of a photograph of the PROJECT showing the sign required by Section 18, and (5) a Final

Project Report as described in Exhibit G, Assistance Project Schedule. As part of the documentation accompanying the request for final reimbursement, PROJECT SPONSOR shall provide proof of payment of all contractors, material suppliers, engineers, architects, and surveyors with whom PROJECT SPONSOR has directly contracted (each a "DIRECT PROVIDER") to provide services or materials for the PROJECT. The final reimbursement amount shall be adjusted as necessary such that neither the total ASSISTANCE AMOUNT nor the MATCHING PERCENTAGE is exceeded. Unless otherwise determined by the DISTRICT, the final reimbursement check shall be presented by a DISTRICT representative to the PROJECT SPONSOR during a public commission meeting or public dedication ceremony for the PROJECT.

9. **RECORDS RETENTION** - The PROJECT SPONSOR shall retain all records supporting the PROJECT COSTS for three (3) years after the end of the fiscal year in which the Final Payment is released by the DISTRICT, except that such records shall be retained by the PROJECT SPONSOR until final resolution of matters resulting from any litigation, claim, or special audit that starts prior to the expiration of the three-year retention period.

10. **DEFAULT AND REMEDIES** – In the event of a breach of any of the terms of this AGREEMENT by the PROJECT SPONSOR, the DISTRICT shall provide written notice to the PROJECT SPONSOR, which shall have sixty (60) days in which to cure the breach. If the PROJECT SPONSOR fails to cure the breach within the cure period, the DISTRICT shall have the right, but not the obligation, to demand that the PROJECT SPONSOR immediately refund the ASSISTANCE AMOUNT to the extent paid. PROJECT SPONSOR shall refund to the DISTRICT the full amount of the ASSISTANCE AMOUNT paid to PROJECT SPONSOR, whereupon this AGREEMENT, and all further rights thereunder, shall be terminated. If the DISTRICT does not demand reimbursement as aforesaid, the DISTRICT may exercise any and all other remedies available at law or in equity. With respect to the PROJECT SPONSOR's obligations under Sections 15, 17, and 20, PROJECT SPONSOR acknowledges that breach by the PROJECT SPONSOR of one or more of its obligations under said sections might cause the DISTRICT to suffer irreparable harm, namely harm for which damages would be an inadequate remedy. PROJECT SPONSOR further acknowledges that the DISTRICT might suffer irreparable harm due to delay if, as a condition to obtaining an injunction, restraining order, or other equitable remedy with respect to such a breach, the DISTRICT was required to demonstrate that it would suffer irreparable harm. The parties therefore intend that if the PROJECT SPONSOR breaches one or more of its obligations under Sections 15, 17, or 20, the DISTRICT, in addition to such other remedies which may be available, shall have the right to seek specific

performance and injunctive relief, and for purposes of determining whether to grant an equitable remedy any court will assume that the breach would cause the DISTRICT irreparable harm. The provisions of this section shall survive completion of the PROJECT.

11. **DISTRICT PROJECT MANAGER** - The Executive Director, or his designee, is hereby designated as the DISTRICT's Project Manager for the purpose of this AGREEMENT and shall be responsible for monitoring performance of its terms and conditions and for approving all reimbursement requests prior to payment.

12. **PROJECT SPONSOR'S LIAISON AGENT** - The PROJECT SPONSOR shall appoint a LIAISON AGENT, whose name and title shall be submitted to the DISTRICT upon execution of this AGREEMENT, to act on behalf of the PROJECT SPONSOR relative to the provisions of this AGREEMENT.

13. **STATUS REPORTS** - The PROJECT SPONSOR or LIAISON AGENT shall submit to the DISTRICT project status reports during the PROJECT term. These Quarterly Reports are to be on Form #95-02 (Exhibit F, Assistance Program Project Quarterly Status Report). Project design drawings, engineering drawings, and a copy of the Project bid award construction item cost list will be submitted as available. Photographs shall be submitted when appropriate to reflect the work accomplished. NON-COMPLIANCE by the PROJECT SPONSOR with the reporting schedule in Exhibit G, Assistance Project Schedule, may result in revocation of this AGREEMENT.

14. **LAWS** - The PROJECT SPONSOR agrees to obtain and to abide by all federal, state, and local permits and proprietary authorizations, and all applicable laws and regulations in the development of the PROJECT. The PROJECT SPONSOR agrees that all PROJECT facilities shall be designed and constructed in compliance with applicable state and federal statutory requirements for accessibility by handicapped persons, as well as all other federal, state and local laws, rules, and requirements.

15. **NON-DISCRIMINATION** - The PROJECT SPONSOR agrees that when completed, the PROJECT shall be readily accessible, on a non-exclusive basis, to the general public without regard to age, sex, race, physical handicap, or other condition, and without regard to residency of the user in another political subdivision.

16. **PARKING FACILITIES** - Adequate parking shall be made available by the PROJECT SPONSOR to accommodate vehicles for the number of persons for which the PROJECT is being developed.

17. **SITE DEDICATION** - The PROJECT SPONSOR also agrees that the PROJECT site shall be dedicated for the public use for a minimum period of thirty-five (35) years from the completion of the PROJECT, such dedication to be in the form of a deed, lease, management AGREEMENT or other legally binding document. Any change in such dedication shall require the prior approval of the DISTRICT. The PROJECT SPONSOR shall record evidence of such dedication within the Public Records of the County in which the PROJECT is located.

18. **ACKNOWLEDGMENT** – For construction projects, the PROJECT SPONSOR shall erect a permanent sign, approved by the DISTRICT, in a prominent location such as the PROJECT entrance of the completed PROJECT, which shall indicate that the DISTRICT contributed funds for the PROJECT. The wording of the sign required by this section shall be approved by the DISTRICT's staff before construction and installation of said sign. This sign shall contain the DISTRICT logo (Exhibit H) unless otherwise stipulated by the DISTRICT. In the event that the PROJECT SPONSOR erects a temporary construction sign, it shall also indicate the DISTRICT's participation. For all other types of projects, the PROJECT SPONSOR shall acknowledge the DISTRICT where feasible, in concurrence with the DISTRICT staff's recommendations.

19. **PROJECT MAINTENANCE** - When and as applicable, the PROJECT SPONSOR agrees to operate, maintain, and manage the PROJECT for the life of the PROJECT improvements and will pay all expenses required for such purposes. The PROJECT improvements shall be maintained in accordance with the standards of maintenance for other local facilities owned and operated by the PROJECT SPONSOR, and in accordance with applicable health standards. PROJECT facilities and improvements shall be kept reasonably safe and in reasonable repair to prevent undue deterioration and to encourage public use. The PROJECT SPONSOR warrants and represents that it has full legal authority and financial ability to operate and maintain said PROJECT facilities and improvements.

20. **FEES** – Any fees charged for this PROJECT shall be reasonable and the same for the general public of all member counties. The PROJECT SPONSOR must demonstrate that a minimum of fifty percent (50%) of the PROJECT fees will be utilized for project maintenance and improvements throughout the anticipated life of a development project or the design life of other project types, as applicable.

21. **SOVEREIGN IMMUNITY** - Each party hereto agrees that it shall be solely responsible for the wrongful acts of its employees, contractors, and agents. However, nothing contained herein shall constitute a waiver by either party of its sovereign immunity under Section

768.28, Florida Statutes. The PROJECT SPONSOR acknowledges that the DISTRICT, its employees, commissioners, and agents are solely providing funding assistance for the PROJECT and are not involved in the design, construction, operation, or maintenance of the PROJECT.

22. **INSPECTIONS** - The DISTRICT reserves the right, upon reasonable request, to inspect said PROJECT and any and all records related thereto at any time.

23. **RIGHTS AND DUTIES** - The rights and duties arising under this AGREEMENT shall inure to the benefit of and be binding upon the parties hereto and their respective successors and assigns, and shall, unless the context clearly requires otherwise, survive completion of the PROJECT. The PROJECT SPONSOR may not assign this AGREEMENT nor any interest hereunder without the express prior written consent of the DISTRICT.

24. **WAIVERS** - Waiver of a breach of any provisions of this AGREEMENT shall not be deemed a waiver of any other breach of the same or different provision.

25. **NOTICE** - Any notice required to be given pursuant to the terms and provisions of this AGREEMENT shall be in writing, postage paid, and shall be sent by certified mail, return receipt requested, to the DISTRICT or PROJECT SPONSOR at the addresses below. The notice shall be effective on the date indicated on the return receipt.

To the DISTRICT at:

Florida Inland Navigation District
1314 Marcinski Road
Jupiter, Florida 33477-9498

To the PROJECT SPONSOR at:

Bal Harbour Village
Attention: Grant Administrator, Capital Programs
655 96th Street
Bal Harbour Village, FL 33154

26. **NO JOINT VENTURE** - The DISTRICT's role with respect to the PROJECT is that of a funding assistance authority only and the DISTRICT is not, and shall not be considered to be, an agent, partner, or joint venturer with the PROJECT SPONSOR.

27. **GOVERNING LAW** - The validity, interpretation, and performance of this AGREEMENT shall be controlled and construed according to the laws of the State of Florida.

28. **TRANSFERENCE** - It is the intent of the DISTRICT to issue this funding assistance to the PROJECT SPONSOR who has made application for this assistance. In the event the PROJECT SPONSOR transfers ownership or management of the PROJECT to a party or parties not now a part of this AGREEMENT, other than another governmental entity that agrees to assume, in writing, PROJECT SPONSOR'S obligation hereunder, the DISTRICT retains the right to full reimbursement from the PROJECT SPONSOR to the full extent of the funding assistance provided by the DISTRICT including, but not limited to, any costs and reasonable attorney's fees (regardless of whether litigation ensues) incurred by the DISTRICT in collecting said reimbursement.

29. **ENTIRE UNDERSTANDING** - This AGREEMENT, including any exhibits made a part hereof, embodies the entire AGREEMENT and understanding of the parties and supersedes all prior oral and written communications between them. The terms hereof may be modified only by a written amendment signed by both parties hereto.

IN WITNESS WHEREOF, the parties hereto have caused these presents to be executed the day, month and year aforesaid.

FLORIDA INLAND NAVIGATION DISTRICT

By: _____

Executive Director

Date: _____

10/28/24

Bal Harbour Village

By: _____

Title: _____

Date: _____

Village Manager
10/25/2024

Exhibit A

PROJECT COST ESTIMATE

WATERWAY ASSISTANCE PROGRAM FY 2024

(See Rule Section 66B-2.005 & 2.008 for eligibility and funding ratios)

Project Title:	Village Jetty and Cutwalk Segment B
Applicant:	Bal Harbour Village

Project Elements <i>(Please list the MAJOR project elements and provide general costs for each one. For Phase I Projects, please list the major elements and products expected)</i>	Total Estimated Cost	Applicant's Cost <i>(To the nearest \$50)</i>	FIND Cost <i>(To the nearest \$50)</i>
Mobilization/Demolition	290,000.00	290,000.00	0.00
Structural work to include, concrete, rip rap and related for reinforcement and elevation	10,000,000.00	7,000,000.00	3,000,000.00
Lighting, railing, benches, and related safety surface features	1,000,000.00	1,000,000.00	0.00
**TOTALS =	\$ 11,290,000.00	\$ 8,290,000.00	\$ 3,000,000.00

Exhibit B 2024
CHAPTER 66B-2
WATERWAYS ASSISTANCE PROGRAM

66B-2.001	Purpose
66B-2.002	Forms
66B-2.003	Definitions
66B-2.004	Policy
66B-2.005	Funds Allocation
66B-2.006	Application Process
66B-2.0061	Emergency Applications
66B-2.007	Application Form (Repealed)
66B-2.008	Project Eligibility
66B-2.009	Project Administration
66B-2.010	Project Agreement (Repealed)
66B-2.011	Reimbursement
66B-2.012	Accountability
66B-2.013	Acknowledgement
66B-2.014	Small-Scale Spoil Island Restoration and Enhancement Projects
66B-2.015	Small-Scale Derelict Vessel Removal Projects
66B-2.016	Waterways Cleanup Events

66B-2.001 Purpose.

Recognizing the importance and benefits of inland navigation channels and waterways, as well as noting problems associated with the construction, continued maintenance and use of these waterways, the Florida Legislature created Section 374.976, F.S. This law authorizes and empowers each inland navigation district to undertake programs intended to alleviate the problems associated with its waterways. The purpose of this rule is to set forth the District's policy and procedures for the implementation of an assistance program under Section 374.976, F.S., for local governments, member counties and navigation related districts within the District. This program will be known hereafter as the Florida Inland Navigation District's Waterways Assistance Program.

Rulemaking Authority 374.976(2) FS. Law Implemented 374.976(1) FS. History—New 12-17-90, Formerly 16T-2.001.

66B-2.002 Forms.

All forms for the administration of this program are available from the District office located at 1314 Marcinski Road, Jupiter, Florida 33477.

Rulemaking Authority 374.976(2) FS. Law Implemented 374.976(1) FS. History—New 12-17-90, Formerly 16T-2.002.

66B-2.003 Definitions.

The basic terms utilized in this rule are defined as follows:

- (1) "APPLICANT" means an eligible governmental agency submitting an application through this program.
- (2) "APPLICATION" means a project proposal with the required documentation.
- (3) "AUTHORIZED SUBMISSION PERIOD" means the established period for submitting applications to the District.
- (4) "BEACH RENOURISHMENT" means the placement of sand on a beach for the nourishment, renourishment or restoration of a beach.
- (5) "BOARD" means the Board of Commissioners of the Florida Inland Navigation District.
- (6) "DISTRICT" means the Florida Inland Navigation District (FIND).
- (7) "ELIGIBLE GOVERNMENTAL AGENCY" means member counties, local governments and navigation related districts within the taxing boundaries of the District.
- (8) "ENVIRONMENTAL PERMITS" means those permits, proprietary authorizations, exemptions, or general

permits for construction below mean high water line of a navigable waterway required and issued by or on behalf of the U.S. Army Corps of Engineers, the Florida Department of Environmental Protection, and the South Florida or the St. Johns River Water Management Districts or their successors.

(9) "EXECUTIVE DIRECTOR" means the Executive Director of the Florida Inland Navigation District.

(10) "LIAISON AGENT" means the contact person officially designated to act on behalf of the applicant or the project sponsor.

(11) "LOCAL GOVERNMENTS" means municipalities, cities, or consolidated county governments, which are located within the member counties.

(12) "MARITIME MANAGEMENT PLAN" means a written plan containing a systematic arrangement of elements specifically formulated to identify, evaluate and promote the benefits of eligible waterway accessibility and enjoyment, with consideration and respect to the physical, environmental and economic parameters of the planning area.

(13) "MATCHING FUNDS" means those funds provided by the local sponsor to the project.

(14) "MEMBER COUNTY" means a county located within the taxing boundaries of the District which includes Nassau, Duval, St. Johns, Flagler, Volusia, Brevard, Indian River, St. Lucie, Martin, Palm Beach, Broward and Miami-Dade Counties.

(15) "NAVIGATION RELATED DISTRICTS" means port authorities, inlet districts or any other agency having legally authorized navigation related duties in waterways of the District.

(16) "PRE-AGREEMENT COSTS" means project costs approved by the District Board which have occurred prior to the execution of the project agreement.

(17) "PROGRAM" means the Florida Inland Navigation District Waterways Assistance Program.

(18) "PROGRAM FUNDS" means financial assistance awarded by the Board to a project for release to the project sponsor pursuant to the terms of the project agreement.

(19) "PROJECT" means a planned undertaking consisting of eligible program facilities, improvements or expenses for the use and benefit of the general public.

(20) "PROJECT AGREEMENT" means an executed contract between the District and a project sponsor setting forth mutual obligations regarding an approved project.

(21) "PROJECT MAINTENANCE" means any usual action, activity, expense, replacement, adjustment or repair taken to retain a project or grant item in a serviceable, operational or normal condition, or the routine efforts and expenses necessary to restore it to serviceable or normal condition, including the routine recurring work required to keep the project or grant item in such condition that it may be continuously used at its original or designed capacity and efficiency for its intended purpose.

(22) "PROJECT MANAGER" means the District employee who is responsible for monitoring the performance of the Project and compliance with the project agreement.

(23) "PROJECT PERIOD" means the approved time during which costs may be incurred and charged to the funded project.

(24) "PROJECT SPONSOR" means an eligible governmental agency receiving program funds pursuant to an approved application.

(25) "PUBLIC BUILDING" means a building or facility on government owned property that is owned or operated by a governmental entity, or operated by a third party operator. The building or facility must provide waterway related information, public meeting space, or educational services and be open to members of the public on a continual basis without discrimination.

(26) "PUBLIC MARINA" means a harbor complex used primarily for recreational boat mooring or storage, the services of which are open to the general public on a first come, first served basis without any qualifying requirements such as club membership, stock ownership, or differential in price.

(27) "PUBLICLY OWNED COMMERCIAL OR INDUSTRIAL WATERWAY ACCESS" means any publicly owned area specifically designed to be used for staging, launching, or off-loading by commercial or industrial waterway users on a first come, first served, short-term basis, to gain entry to or from the District's waterways to serve the infrastructure needs of the District's waterway users.

(28) "WATERWAYS" means the Atlantic Intracoastal Waterway, the Okeechobee Waterway, the Barge Canal in Brevard County west of the Port Canaveral Locks, those portions of the Dania Cut-Off Canal and the Hillsboro Canal

east of the water control structures, all navigable natural rivers, bays, creeks or lagoons intersected by said waterways and all navigable natural creeks, rivers, bays or lagoons entering or extending from said waterways.

(29) "WATERWAY RELATED ENVIRONMENTAL EDUCATION" means an interdisciplinary holistic process by which the learner: develops an awareness of the natural and manmade environments of waterways; develops knowledge about how the environment of the waterways works; acquires knowledge about the technological, social, cultural, political, and economic relationships occurring in waterway related environmental issues; and, becomes motivated to apply action strategies to maintain balance between quality of life and quality of the environment of waterways.

Rulemaking Authority 374.976(2) FS. Law Implemented 374.976(1) FS. History—New 12-17-90, Amended 9-2-92, 2-6-97, Formerly 16T-2.003, Amended 5-17-98, 3-21-01, 3-20-03, 3-3-04, 4-21-05, 4-24-06, 4-15-07, 3-25-08, 3-7-11, 3-25-21.

66B-2.004 Policy.

The following constitutes the policy of the District regarding the administration of the program:

(1) Financial Assistance Eligibility: Financial assistance, support and cooperation may be provided to eligible governmental agencies for approved projects as follows:

(a) Member counties may be provided financial assistance, support or cooperation in planning, acquisition, development, construction, reconstruction, extension, improvement, operation or the maintenance of public navigation, local and regional anchorage management, beach renourishment, public recreation, inlet management, environmental education, maritime management plans, and boating safety projects directly related to the waterways.

(b) Eligible local governments may also be provided financial assistance, support and cooperation in planning and carrying out public navigation, local and regional anchorage management, beach renourishment, public recreation, inlet management, environmental education, and boating safety projects directly related to the waterways.

(c) Navigation related districts may be provided with financial assistance to pay part of the costs of the planning and acquisition of dredge material management sites if the Board finds that the site is required for the long-range maintenance of the Atlantic Intracoastal Waterway channel. All such sites must meet the development and operational criteria established by the District through a long-range dredge material management plan for that county. Navigation related districts may also be provided with assistance for waterway related access projects, environmental mitigation projects associated with waterway improvement related activities, and inlet management projects if the Board finds that the project benefits public navigation in the Atlantic Intracoastal Waterway. All navigation related districts shall contribute at least equal matching funds to any District financial assistance provided. Seaports may also be furnished assistance and support in planning and carrying out environmental mitigation projects. All seaport projects shall benefit publicly maintained channels and harbors. Each seaport shall contribute matching funds for funded projects.

(d) Eligible projects shall include the acquisition and development of public boat ramps and launching facilities, including those in man-made, navigable waterways contiguous to "waterways" as defined in Rule 66B-2.003, F.A.C.

(2) Notification: The District will notify by direct mail, email and/or advertised public notice all eligible governmental agencies of the program and the upcoming authorized submission period.

(3) Project Approval: Approval of projects by the District shall be in accordance with these rules.

(4) Project Accessibility: Facilities or programs funded in whole or in part by program funds shall be made available to the general public of all of the member counties on a non-exclusive basis without regard to race, color, religion, age, sex or similar condition. Additionally, facilities funded in whole or in part by program funds, shall not require a paid membership for the general public of all of the member counties as a condition to use the facilities. User or entrance fees may be charged for the use of facilities funded in whole or in part by program funds, however such fees shall be reasonable and shall be the same for the general public of all of the member counties.

(5) Waterway Impacts: All development projects must be designed so as not to impact navigation along the District's waterways through the placement of structures, attendant uses, or the necessity of a boating speed zone for safety purposes. Before applying for boating speed zone designation in District waterways because of a project funded by this program, the sponsor shall first receive approval from the Board. The Board will use the criteria found in Section 327.46(1), F.S., in determining whether to approve the proposed boating speed zone.

(6) Project Maintenance: The project sponsor shall be responsible for the operation, maintenance, and management of the project for the anticipated life of the project and shall be responsible for all expenses required for such purposes.

The project shall be maintained in accordance with the standards of maintenance for other similar local facilities and in accordance with applicable health standards. Project facilities and improvements shall be kept reasonably safe and in reasonable repair to prevent undue deterioration and to encourage public use. The project sponsor shall have full legal authority and financial ability to operate and maintain the project facilities.

(7) Education Facilities and Programs: Waterways related environmental education facilities and programs sponsored by the District shall occur at specially designated environmental education facilities located adjacent and contiguous to the waterways. It is the District's intent to consolidate its environmental education efforts in the least number of facilities within an area that will adequately serve the education needs of that area of the District.

(8) Public Information Availability: Public information produced with assistance from this program shall not be copyrighted and shall be provided free of cost, except for the cost of reproduction, to the public.

(9) Third-Party Project Operators: Projects that are being operated by a third party shall have sufficient oversight by the eligible project sponsor as determined by the Board. Such oversight, at a minimum, will include a project liaison that is a staff member of the eligible project sponsor, and oversight of the operating hours and admission fees of the facility by the eligible project sponsor through a legal agreement. All third party projects shall be open to the public in accordance with this rule.

(10) Non-compliance: The District shall terminate a project agreement and demand return of program funds disbursed to the project sponsor for non-compliance with any of the terms of the project agreement or this rule, if such non-compliance calls into question the ability of the applicant to complete the project. Failure of a project sponsor to comply with the provisions of this rule or the project agreement shall result in the District declaring the project sponsor ineligible for further participation in the program until such time as compliance has been met to the satisfaction of the District.

(11) Fees: Any public project eligible for District program funds that charges a fee or will charge a fee must create and maintain an enterprise fund for the public project that shall plan for and retain at all times sufficient funds for the ongoing maintenance of the facility during its project life. Accounting records of the previous five years of the public project's enterprise fund will be submitted as part of any subsequent assistance program application to the District.

Rulemaking Authority 374.976(2) FS. Law Implemented 374.976(1), (2) FS. History—New 12-17-90, Amended 2-3-94, 2-6-97, Formerly 161-2.004, Amended 5-18-98, 3-31-99, 5-25-00, 3-21-01, 7-30-02, 3-3-04, 4-21-05, 4-1-09, 2-22-10, 3-7-11, 3-7-12, 1-27-14, 2-17-15.

66B-2.005 Funds Allocation.

The Board will allocate funding for this program based upon the District's overall goals, management policies, fiscal responsibilities and operational needs for the upcoming year. Funding allocations to navigation related districts, member counties and local governments shall be based upon the proportional share of the District's ad valorem tax collections from each county. If funds are determined to be available for the program, the District will notify potential eligible governmental agencies of the availability of program funding. Applications will be reviewed by the Board utilizing District Forms No. 91-25 and 91-25 (A) through (F) Waterways Assistance Program Application and Evaluation Worksheet (effective date 1/2014), hereby incorporated by reference and available at: <http://www.flrules.org/Gateway/reference.asp?No=Ref-03568>, and available from the District office or by download from the District's webpage at: www.aicw.org.

(1) Funding Assistance Availability: In as much as the District has other fiscal responsibilities and operational needs, financial assistance to eligible government agencies shall not exceed an amount equal to eighty (80) percent of the proportional share of the District's ad valorem tax collections from each county in which such agencies are located. The District may make an exception to this funding limitation, if funds are determined to be available based upon the District's overall goals, management policies, fiscal responsibilities and operational needs, or in counties that are recovering from a state of emergency declared under Chapter 252, F.S.

(2) Project Funding Ratio: All financial assistance and support to eligible governmental agencies shall require, at a minimum, equal matching funds from the project sponsor, with the exception of public navigation projects that meet the provisions of subsection 66B-2.005(6), F.A.C., land acquisition projects in accordance with subsection 66B-2.005(7), and Rule 66B-2.008, F.A.C., small-scale spoil island restoration and enhancement projects that meet the provisions of Rule 66B-2.014, F.A.C., derelict vessel projects consistent with Rule 66B-2.0015, F.A.C., and Waterway Cleanup Projects approved under Rule 66B-2.0016, F.A.C., and projects approved in counties recovering from a state of emergency.

Applicant's in-house costs are limited pursuant to paragraph 66B-2.008(1)(c), F.A.C. All financial assistance to seaports shall require equal matching funds. The District shall contribute no more than fifty percent (50%) of the local share of the cost of an inlet management or beach renourishment project. The District shall not contribute funding to both the state and local shares of an inlet management or beach renourishment project.

(3) Pre-agreement Expenses: The project sponsor shall not commence work on an approved project element prior to the execution of the project agreement unless authorized by the Board during the review and funding approval process. Board authorization of pre-agreement expenses will be given for the commencement of work prior to the execution of a project agreement if the Board determines that there is a benefit to the District, its waterways or its constituents. All project costs must be incurred and work performed within the project period as stipulated in the project agreement unless pre-agreement costs are approved by the Board. Pre-agreement expenses will be approved if they are consistent with the provisions of Rule 66B-2.008, F.A.C., and occur within the fiscal year of the grant application submission (October 1st to September 30th). Pre-agreement expenses, except for projects approved by the Board as multi-year projects, will be limited to fifty (50) percent of the project's total cost and if the expenses are eligible project expenses in accordance with this rule. Only one-half (1/2) or less of the approved pre-agreement expenses will be eligible for reimbursement funding from the District, except for projects approved by the Board as multi-year projects. The Board shall consider a waiver of the limitation on pre-agreement expenses for Small-Scale Derelict Vessel grants and land acquisition projects when the applicant demonstrates a direct need and benefit and the project is in accordance with the applicable provisions of Chapter 66B-2, F.A.C.

(4) Multi-Year Funding: The construction phase of projects that are large scale, involve multiple phases, have a construction time line of one year or longer, or are requesting a significant amount of assistance funding in relation to the total assistance available for the county where the project is located, will be reviewed and approved by the District Board for a multiple year period subject to budgeting and allocation pursuant to the provisions of Chapter 200, F.S. The determination by the Board to provide assistance funding on a multi-year basis can be made at any time during the application review process. All approved multi-year projects are limited to a maximum of two (2) additional funding requests.

(5) Inlet Management and Beach Renourishment: Projects and project elements in the categories of inlet management and beach renourishment shall be subject to the following provisions. The District shall contribute no more than fifty percent of the local share of the cost of the project. The District shall not contribute funding to both the state and local shares of an inlet management or beach renourishment project. Funding for the construction phase of an inlet management or beach renourishment project may be approved by the District Board for a multiple year period subject to budgeting and allocation pursuant to the provisions of Chapter 200, F.S. Additionally the following provisions shall be met for inlet management or beach renourishment projects:

(a) Inlet Management: Inlet management projects shall benefit public navigation within the District and shall be consistent with Department of Environmental Protection approved inlet management plans and the statewide beach management plan pursuant to Section 161.161, F.S. Prior to funding any inlet management project, the Board shall make a finding that the project is a benefit to public navigation in the District. Inlet management projects that are determined to be consistent with Department of Environmental Protection approved inlet management plans are declared to be a benefit to public navigation.

(b) Beach Renourishment: All projects in this category shall be consistent with the statewide beach management plan. Beach renourishment projects shall only include those beaches that have been adversely impacted by navigation inlets, navigation structures, navigation dredging, or a navigation project. Prior to funding any beach renourishment project, the Board shall make a finding that the beaches to be nourished have been adversely impacted by navigation inlets, navigation structures, navigation dredging or a navigation project. The determination of beach areas that are adversely impacted by navigation for the purposes of this program shall be made by Department of Environmental Protection approved inlet management plans. If state funding is not provided for a beach project, public access with adequate parking must be available in accordance with Chapter 161, F.S.

(6) Public Navigation: Projects or project elements in the category of public navigation that will qualify for up to seventy-five percent (75%) program funds must be within the Intracoastal Right-of-Way (ROW), or provide public navigation channel access to two or more publicly accessible launching, mooring or docking facilities. In addition, the following shall apply:

(a) Navigation channel dredging: The project sponsor must demonstrate that the source of channel sedimentation has been identified and is in the process of, or has been controlled, or that the frequency and amount of shoaling is such that dredging will provide an improvement to the channel that will last for twenty (20) years or more and therefore is more cost effective than identifying and correcting the cause of shoaling, or that the cost of identifying the source of channel sedimentation exceeds the cost of the dredging project.

(b) Navigation channel lighting and markers must be located on primary or secondary public navigation channels. Navigation projects or project elements that have one facility open to the public will qualify for up to fifty percent (50%) program funding. Dredging that is associated or ancillary to another use (such as a boat ramp, marina or pier) will be prioritized according to the associated use.

(7) Land Acquisition: Land acquisition projects shall qualify for a maximum of fifty (50) percent funding. All pre-agreement expenses for land acquisition must be completed within one-year of the date of application for funding. Except for acquisition of publicly owned spoil disposal site, all funded land acquisition projects must construct the required boating access facility within 7 years of completion of the land acquisition, or the District may require the applicant to refund the program funding. Immediately upon acquiring title to the land, the applicant shall record a declaration of covenants in favor of the District stating that if the required boating access facility is not constructed within 7 years and dedicated for the public use as a boating access facility in perpetuity after completion of construction, the District shall require the applicant to refund the program funding.

(8) Seaport Funding Eligibility: Financial assistance to seaports may exceed the proportional share of the District's ad valorem tax collections as set forth in subsection 66B-2.005(1), F.A.C., from the county in which such seaport is located if the seaport can demonstrate that a regional benefit occurs from the port's activities. Financial assistance to a seaport project that demonstrates a regional benefit shall not exceed an amount equal to (i) the proportional share of the District's ad valorem tax collections as set forth in subsection 66B-2.005(1), F.A.C., from the counties where the benefit is demonstrated less (ii) funding allocated in the same fiscal year to all other local government projects funded in those counties.

Rulemaking Authority 374.976(2) FS. Law Implemented 374.976(1), (3) FS. History--New 12-17-90, Amended 6-24-93, 9-5-96, 2-6-97, Formerly 16T-2.005, Amended 5-17-98, 8-26-99, 3-21-01, 7-30-02, 3-3-04, 4-21-05, 4-24-06, 4-15-07, 3-25-08, 4-1-09, 3-7-11, 3-7-12, 4-10-13, 1-27-14, 5-15-16, 3-25-21.

66B-2.006 Application Process.

(1) Application Period: With the exception of eligible Disaster Relief Projects, eligible Small-Scale Spoil Island Restoration and Enhancement Projects eligible Small-Scale Derelict Vessel Applications and Waterway Cleanup Events, all applications for assistance through this program will be submitted during the authorized submission period that shall be established by vote of the Board at a scheduled meeting.

(2) Application Forms: Florida Inland Navigation District Waterways Assistance Program Project Application FIND Form Number 90-22 (effective date 4-24-06) and the Waterway Assistance Program Application and Evaluation Worksheet No. 91-25 and 91-25 (A) through (F) (effective date 1/2014) are hereby incorporated by reference and available from the District office. With the exception of projects eligible under the Small-Scale Spoil Island Restoration and Enhancement program, the Small-Scale Derelict Vessel program, and eligible Waterway Cleanup Events, all applications for financial assistance and support through this program from member counties and local governments shall be made on Form Number FIND 90-22 and the Waterway Assistance Program Project Application and Evaluation Worksheet No. 91-25 and 91-25 (A) through (F) and shall include a detailed cost estimate submitted on FIND Form No. 90-25, Florida Inland Navigation District Assistance Program Project Cost Estimate, (effective date 4-24-06), hereby incorporated by reference and available from the District office. In addition, all applicants shall submit a complete and detailed Project Timeline (FIND FORM No. 96-10) (effective date 4-15-07).

(3) Sponsor Resolution: The project sponsor shall approve the submission of an application by official resolution from its governing board or commission. Said resolution shall be made on FIND Form No. 90-21, Resolution for Assistance Under the Florida Inland Navigation District Waterways Assistance Program (effective date 10-14-92), hereby incorporated by reference and available from the District office.

(4) Attorney's Certification: If the application is for a project that is a land based development project the applicant shall submit an Attorney's Certification of Title, FIND Form Number 94-26 (effective date 5-25-00), hereby incorporated

by reference and available from the District office.

(5) Maps and Geographic Information: All applicants shall be required to submit, at minimum, the following geographic information: A County location map, a project location map, a project boundary map, and a clear and detailed site development map for land development projects.

(6) Application Review: Applicants shall obtain the local FIND Commissioner's initials on Form No. 90-26 prior to submitting the application to the District office. It is the applicant's responsibility to make timely arrangements for the local FIND Commissioner's review. In the absence of extenuating circumstances outside of the applicant's control as determined by the Board of Commissioners, an application shall not be considered complete if it does not include the local FIND commissioner's initials on Form No. 90-26. Upon receipt in the District office, staff will review the applications for completeness of the informational requirements identified in the Application Checklist, FIND Form Number 90-26 (effective date 7-30-02), and for compliance with the eligibility requirements of this rule. When an application is determined by staff to be incomplete or ineligible, staff will immediately inform the applicant by mail. The applicant will then have until the date established by the Board in the application package to bring the application into compliance. If the applicant fails to provide a complete application in compliance with these rules, the application will not be considered for funding. In order to have a complete application, the applicant shall not only submit the forms required under Rule 66B-2.006, F.A.C., and any other information requirements identified in the Application Checklist (FIND Form Number 90-26), but such forms and other submitted information must be completely filled out, executed as applicable, and also establish compliance with Chapter 66B-2, F.A.C.

(7) Interlocal Agreements: Applications that the Board determines will directly benefit the maintenance of the Atlantic Intracoastal Waterway channel as documented by the District's long range dredged material management plans, will directly benefit the maintenance of the Okeechobee Waterway channel as documented by the District's long range dredged material management plan, will directly benefit the maintenance or improvement of District property, right-of-way or navigation interests, or have multiple funding partners including the Corps of Engineers as the project manager can qualify for project assistance through an interlocal agreement pursuant to Chapter 163 or Section 374.984(6)(a), F.S. District staff will identify these applications and present them to the Board for their determination as to funding. Interlocal agreement projects shall comply with all other provisions of this rule, except for pre-agreement expenses, permitting and property control requirements.

(8) Application Presentations: Applications determined to be complete and in compliance with this rule will be forwarded to the Board for review and then scheduled for presentation to the Board at a scheduled meeting of the Board. Applicants can decline to make a presentation to the Board by submitting a written request.

(9) Application Evaluation and Rating Score: Following the presentations, the Board will review the applications and evaluate them using the Waterways Assistance Program Application and Evaluation Worksheets No. 91-25 (A) through (F) for Waterways Assistance Program applications. The total points awarded to each application by the Commissioners will be averaged to determine an application's final rating score. The final rating score for each application must equal or exceed 35 points for the application to be considered for funding assistance. Reconsideration of any application with a final rating score of less than 35 points will only occur if the majority of the Commissioners evaluating the project rated the project equal to or exceeding 35 points and two-thirds of the Commissioners vote for reconsideration of the application. Only Applicants that are eligible under Rule 66B-2.0061, F.A.C., "Disaster Relief Applications," shall complete FIND Form No. 91-25F Emergency Re-Construction (effective date 4-24-06, 1/2014).

(10) Funding Determination: The Board will hold a funding allocation meeting at which time the Board will determine the allocation of funds, if any, to each project and the projects will be ranked by overall average score to facilitate final funding decisions by the Board. Allocations will be based in part upon the cumulative score of the applications as calculated from the Project Evaluation and Rating Form. Allocations will also be based upon the specific needs of the individual counties.

Rulemaking Authority 374.976(2) FS. Law Implemented 374.976(1) FS. History--New 12-17-90, Amended 9-2-92, 6-24-93, 4-12-95, Formerly 16T-2.006, Amended 5-25-00, 3-21-01, 7-30-02, 3-20-03, 4-21-05, 4-24-06, 4-15-07, 3-25-08, 3-7-11, 1-27-14.

66B-2.0061 Disaster Relief Applications.

Disaster Relief applications may be submitted to the District and considered by the Board at any time during the year to provide assistance to an eligible applicant for the removal of navigation obstructions and repair or replacement of

waterway facilities damaged by a declared natural disaster. Applicants for Disaster Relief shall use the same forms listed in subsection 66B-2.006(2), F.A.C. The District shall consider these applications in accordance with these rules.

Rulemaking Authority 374.976(2) FS. Law Implemented 374.976(1) FS. History—New 6-24-93, Amended 2-6-97, Formerly 16T-2.0061, Amended 4-24-06, 3-25-21.

66B-2.007 Application Form.

Rulemaking Authority 374.976(2) FS. Law Implemented 374.976(1) FS. History—New 12-17-90, Amended 6-24-93, 2-3-94, 4-12-95, Formerly 16T-2.007, Repealed 7-30-02.

66B-2.008 Project Eligibility.

(1) Eligible Projects: Financial assistance and support through this program shall be used to plan or carry out public navigation and anchorage management, public recreation, environmental education, boating safety, acquisition and development of spoil sites and publicly owned commercial/industrial waterway access directly related to the waterways, acquisition and development of public boat ramps, launching facilities and boat docking and mooring facilities, inlet management, maritime management planning, environmental mitigation and beach renourishment.

(a) Program funds may be used for projects such as acquisition, planning, development, construction, reconstruction, extension, or improvement, of the following types of projects for public use on land and water. These project types will be arranged into a priority list each year by vote of the Board. The priority list will be distributed to applicants with the project application.

1. Public navigation channel dredging,
2. Public navigation aids and markers,
3. Inlet management projects that are a benefit to public navigation in the District,
4. Public shoreline stabilization directly benefiting the District's waterway channels,
5. Acquisition and development of publicly owned spoil disposal site and public commercial/industrial waterway access,
6. Waterway signs and buoys for safety, regulation or information,
7. Acquisition, dredging, shoreline stabilization and development of public boat ramps and launching facilities,
8. Acquisition, dredging, shoreline stabilization and development of public boat docking and mooring facilities,
9. Derelict Vessel Removal,
10. Waterways related environmental education programs and facilities,
11. Public fishing and viewing piers,
12. Public waterfront parks and boardwalks and associated improvements,
13. Maritime Management Planning,
14. Waterways boating safety programs and equipment,
15. Beach renourishment on beaches adversely impacted by navigation inlets, navigation structures, navigation dredging, or a navigation project; and,
16. Environmental restoration, enhancement or mitigation projects; and,
17. Other waterway related projects. Waterway projects that do not meet specific criteria in subsection 66B-2.005(5) or (6) or subparagraphs 66B-2.008(1)(a)1.-16., F.A.C., but are located on eligible waterways shall be considered for funding under the priority listing of "other waterway related project" and eligible for 25% funding.

(b) Ineligible Projects or Project Elements. Project costs ineligible for program funding or matching funds will include: contingencies, miscellaneous, reoccurring personnel related costs, irrigation equipment, ball-courts, park and playground equipment, and any extraneous recreational amenities not directly related to the waterway such as the following:

1. Landscaping that does not provide shoreline stabilization or aquatic habitat,
2. Restrooms for non-waterway users,
3. Roadways providing access to non-waterway users,
4. Parking areas for non-waterway users,
5. Utilities for non-waterway related facilities,
6. Lighting for non-waterway related facilities,

7. Project maintenance and maintenance equipment,
8. Picnic shelters and furniture for non-waterway related facilities,
9. Vehicles to transport vessels; and,
10. Operational items such as fuel, oil, etc.
11. Office space that is not incidental and necessary to the operation of the main eligible public building; and,
12. Conceptual project planning, including: public surveys, opinion polls, public meetings, organizational conferences; and,
13. Inlet maintenance.

(c) Project Elements with Eligibility Limits: Subject to approval by the Board of an itemized expense list:

1. The following project costs will be eligible for program funding or as matching funding if they are performed by an independent contractor:
 - a. Project management, administration and inspection,
 - b. Design, permitting, planning, engineering or surveying costs for completed construction project,
 - c. Restoration of sites disturbed during the construction of an approved project,
 - d. Equipment costs.

Before reimbursement is made by the District on any of the costs listed in subparagraph 1., above, a construction contract for the project, approved and executed by the project sponsor and project contractor must be submitted to the District.

2. Marine fire-fighting, Marine law enforcement and other vessels are eligible for a maximum of \$125,000 in initial District funding. All future replacement and maintenance costs of the vessel and related equipment will be the responsibility of the applicant.

3. Waterway related environmental education facility funding will be limited to those project elements directly related to the District's waterways.

(d) Phasing of Projects: Applications for eligible waterway projects may be submitted as a phased project where Phase I will include the design, engineering and permitting elements and Phase II will include the construction of the project. A description and cost estimate of the Phase II work shall be submitted along with the Phase I application for Board review.

(2) Property Control: The site of a new proposed land-based development project, with the exception of those projects requesting Small-Scale Spoil Island Restoration and Enhancement funding, shall be dedicated for the public use for which the project was intended for a minimum period of 35 years after project completion. Such dedication shall be in the form of a deed, lease, management agreement or other legally binding document and shall be recorded in the public property records of the county in which the property is located. This property control requirement also applies to a project site owned by another governmental entity. The governmental entity that owns the project site may be joined as a co-applicant to meet this property control requirement. Existing land based development projects that are being repaired, replaced or modified must demonstrate that the project site has been dedicated for public use for at least 25 years with at least 10 years remaining on the dedication document. Property shall also be deemed dedicated for public use if:

(a) The property has been designated for the use for which the project is intended (even though there may have been no formal dedication) in a plat or map recorded prior to 1940, or

(b) The project sponsor demonstrates that it has had exclusive control over the property for the public use for which the project is intended for a period of at least 30 years prior to submission of the application, or

(c) There is no ongoing litigation challenging the designated use of the property as shown on the plat or map, nor has there been any judicial determination contrary to the use by the public for the use shown on the plat or map.

(3) Permits: The project sponsor is responsible for obtaining and abiding by any and all federal, state and local permits, laws, proprietary authorizations and regulations in the development and operation of the project. Applicants for construction projects that include elements that require state or federal environmental permits or proprietary authorizations will demonstrate that all required environmental permitting and authorizations will be completed by the third Monday in September. This demonstration will be by submission of the required environmental permit(s) and authorizations, or by submission of a letter from the agency(s) stating that a permit or authorization is not required. Failure to timely submit the required environmental permits and authorizations or letters stating such permits or authorizations are not required shall result in the application not being considered for funding.

(4) Public Marina Qualifications: All public marina projects funded through this program shall include sewage

pumpout facilities for vessels, unless the applicant can demonstrate that inclusion of such a facility is physically, operationally or economically impracticable. All public marina projects funded through this program shall have at least ten percent (10%) of their slips or mooring areas available for transient vessels. Public marina dockage rates shall be within market comparison of the dockage rates of other area marinas. The public marina will be required to establish and maintain an accounting of the funds for the facility and shall plan for and retain at all times sufficient funds for the on-going maintenance of the facility during its project life.

(5) The District may assist eligible local governments with efforts to prepare and implement a comprehensive maritime management plan. The plan shall be utilized by the eligible government to promote and maximize the public benefit and enjoyment of eligible waterways, while identifying and prioritizing the waterway access needs of the community. The plan should not duplicate any existing or ongoing efforts for the same waterway or water shed, nor shall the District participate in any effort that does not address the basic maritime needs of the community.

(a) Existing plans may be updated at reasonable intervals or amended to include waterway areas previously not included in the original effort. Public, government, environmental, industry and other pertinent interest groups shall be solicited and included for input in the planning process.

(b) The plan shall be utilized as a tool to provide a minimum 5-year planning analysis and forecast for the maritime needs of the community, and shall include, at minimum, the following:

1. Public boat ramp and ramp parking inventory and analysis.
2. Public mooring and docking facility analysis, including day docks and transient slips.
3. Commercial and working waterfront identification and needs analysis.
4. The identification, location, condition and analysis of existing and potential navigation channels.
5. An inventory and assessment of accessible public shorelines.
6. Public Waterway transportation needs.
7. Environmental conditions that affect boat facility siting, a current resource inventory survey, and restoration opportunities.
8. Economic conditions affecting the boating community and boating facilities.
9. Acknowledgment and coordination with existing data and information, including an emphasis on the Intracoastal Waterway.

(c) Projects requested for assistance program funding shall be consistent with the applicant's maritime management plan. The applicant should utilize the plan to assist in prioritizing waterway improvement projects.

(6) All eligible environmental restoration, enhancement or mitigation projects as well as the environmental restoration, enhancement or mitigation components of other types of projects shall be required to pursue and assign any available mitigation credits to the District for that share of the project funded through the District's Assistance Program. All eligible environmental restoration, enhancement or mitigation projects shall provide public access where possible.

(7) Final Decisions: The Board will make all final decisions on the eligibility of a Project or specific project costs.

Rulemaking Authority 374.976(2) FS. Law Implemented 374.976(1)-(3) FS. History--New 12-17-90, Amended 9-2-92, 6-24-93, 2-3-94, 4-12-95, 9-5-96, 2-6-97, Formerly 16T-2.008, Amended 5-17-98, 3-31-99, 5-25-00, 3-21-01, 7-30-02, 3-20-03, 3-3-04, 4-15-07, 3-25-08, 4-1-09, 2-22-10, 3-7-11, 3-7-12, 1-27-14, 2-17-15, 2-21-16, 3-25-21, 3-9-23, 3-11-24.

66B-2.009 Project Administration.

The District will appoint a project manager who shall be responsible for monitoring the project and the project agreement. The project manager shall also be responsible for approving all reimbursement requests. The project sponsor shall appoint a liaison agent, who will be a member of the eligible applicant's staff, to act on its behalf in carrying out the terms of the project agreement. Administration of the project will be as follows:

(1) Project Agreement: For each funded project, the District and the project sponsor will enter into a project agreement. The project agreement shall be executed and returned by the project sponsor within six (6) months of the approval of the project funding and prior to the release of program funds, setting forth the mutual obligations of the parties concerning the project. The project agreement shall incorporate the applicable policies and procedures of the program as outlined in this rule. Project agreements will be for a two-year period with the possibility for one, one-year extension. Any request for a one-year extension of funding shall require submittal by the PROJECT SPONSOR of a request for extension to the DISTRICT no later than July of fiscal year two of the approved project. This request will then be

considered by the DISTRICT Board, whose decision shall be final. In review of these requests, the Board will take into consideration the current status and progress of the project and the ability of the applicant to complete the project within one additional year.

(2) Matching Funds: The project sponsor shall clearly identify and enumerate the amount and source of the matching funds it will be using to match the program funds supplied by the District for an approved project. The project sponsor shall provide suitable evidence that it has the matching funds available at the time the project agreement is executed.

(3) Agreement Modification: All proposed changes to the project agreement must be submitted to the District in writing by the project sponsor accompanied by a statement of justification for the proposed changes. All project agreement amendments shall be approved by the District Board, except that the Executive Director may approve a minor project agreement amendment for a project within a county with the local District commissioner's concurrence. A minor project amendment shall not change the approved project's category, result in a reallocation of more than 35% of the approved funding of the project among project elements, nor allow for a greater than 35% change in the project scale or scope of work. Project agreement amendments will not include a change to the approved project's location or a change in the approved project's purpose or project type. Agreed changes shall be evidenced by a formal amendment to the project agreement and shall be in compliance with these rules.

(4) Project Reporting: The liaison agent will submit quarterly reports to the project manager summarizing the work accomplished since the last report, problems encountered, percentage of project completion and other appropriate information. These reports shall continue throughout the length of the project period until completion of the project. The report shall be submitted on Form 95-02, "Assistance Program Project Quarterly Status Report," dated 7-30-02, hereby incorporated by reference and available at the District office. A Final Project Report shall be submitted at the completion of the project and shall at minimum include: project summary, photo of completed project, final cost, project benefits to the waterway and location address.

(5) Reimbursement Requests: The liaison agent may submit periodic reimbursement requests during the project period in accordance with Rule 66B-2.011, F.A.C. The project manager will approve or disapprove all reimbursement requests. The final payment of program funds will be made upon certified completion of the project by the District.

(6) Project Inspection: Upon reasonable request, the project manager shall have the right to inspect the project and any and all records relating to the project.

(7) Project Completion: The project shall be completed within three (3) years of the date of the beginning of the District's first fiscal year for which the project was approved. If the completion of a project is impacted by a declared state of emergency and the Board waives this rule section, the extension of time granted shall not exceed one additional three (3) year period.

(8) Project Completion Requirements: Upon completion of the project, the liaison agent shall provide the following to the project manager:

(a) A Project Completion Certificate, FIND Form No. 90-13 (effective date 7-30-02), hereby incorporated by reference and available from the District office, which certifies that the project was completed in accordance with the project agreement and the final project plans.

(b) A final reimbursement request accompanied by all required billing statements and vouchers.

(c) Photograph(s) showing the installation of the sign required by Rule 66B-2.013, F.A.C.

(d) Photograph(s) of the completed project clearly showing the program improvements.

(9) Project Completion Review: The project manager will review the project completion package and will authorize or reject the final reimbursement payment which will include all retained funds from previous requests.

Rulemaking Authority 374.976(2) FS. Law Implemented 374.976(1) FS. History—New 12-17-90, Formerly 16T-2.009, Amended 3-21-01, 7-30-02, 3-7-11, 1-27-14, 3-25-21.

66B-2.010 Project Agreement.

Rulemaking Authority 374.976(2) FS. Law Implemented 374.976(1) FS. History—New 12-17-90, Amended 9-5-96, Formerly 16T-2.010, Amended 3-21-01, Repealed 7-30-02.

66B-2.011 Reimbursement.

The District shall release program funds in accordance with the terms and conditions set forth in the project agreement.

This release of program funds shall be on a reimbursement only basis. The District shall reimburse the project sponsor for project costs expended on the project in accordance with the project agreement. Project funds to be reimbursed will require the submission of a Reimbursement Request Form and required supporting documents, FIND Form No. 90-14 (effective date 7-30-02) hereby incorporated by reference and available from the District office.

(1) Authorized Expenditures: Project funds shall not be spent except as consistent with the project agreement cost estimate that was approved by the Board, which shall be an attachment to the project agreement. This cost estimate will establish the maximum funding assistance provided by the District and the percentage of funding provided by each party to the project. The District will pay the lesser of:

- (a) The percentage total of project funding that the Board has agreed to fund, or
- (b) The maximum application funding assistance amount.

(2) Phase I Reimbursement: In accordance with these rules, reimbursement cannot be made on a Phase I application until a construction contract is executed by the applicant for the construction phase of the project. If the Phase I project is completed but a construction contract is not executed by the three (3) year project deadline, then the District shall only allow one (1) year from the Phase I project deadline to enter into the required construction contract before the Phase I funding is cancelled.

(3) Reimbursement Requests: All project costs shall be reported to the District and summarized on the Reimbursement Request Form. All requests for reimbursement shall include supporting documentation such as billing statements for work performed and cancelled payment vouchers for expenditures made.

(4) Retainage: The District shall retain ten percent (10%) of all reimbursement payments until final certification of completion of the project. The District shall withhold any reimbursement payment, either in whole or part, for non-compliance with the terms of this agreement.

(5) Check Presentations: A District representative shall present the final reimbursement check to the project sponsor during a public commission meeting or public dedication ceremony for the project facility.

(6) Recovery of Additional Project Funding: If the project sponsor receives additional funding for the project costs from another source that was not identified in the original application and that changes the agreement cost-share percentage, the project sponsor shall proportionately reimburse the District's program funds equal to the cost-share percentage in the approved project agreement. The project sponsor shall promptly notify the District of any project payments it receives from a source other than the District.

Rulemaking Authority 374.976(2) FS. Law Implemented 374.976(1) FS. History--New 12-17-90, Amended 6-24-93, Formerly 16T-2.011, Amended 3-31-99, 7-30-02, 3-7-11.

66B-2.012 Accountability.

The following procedures shall govern the accountability of program funds:

(1) Accounting: Each project sponsor is responsible for maintaining an accounting system which meets generally accepted accounting principles and for maintaining such financial records as necessary to properly account for all program funds.

(2) Quarterly Reports: The project sponsor shall submit quarterly project status reports to FIND in accordance with subsection 66B-2.009(4), F.A.C.

(3) Completion Certification: All required final completion certification documents and materials as outlined in subsection 66B-2.009(8), F.A.C., of this rule shall be submitted to the District prior to final reimbursement of program funds.

(4) Auditing: All project records including project costs shall be available for review by the District or by an auditor selected by the District for 3 years after completion of the project. Any such audit expenses incurred shall be borne entirely by the project sponsor.

(5) Project Records: The project sponsor shall retain all records supporting project costs for three years after either the completion of the project or the final reimbursement payment, whichever is later, except that should any litigation, claim, or special audit arise before the expiration of the three year period, the project sponsor shall retain all records until the final resolution of such matters.

(6) Repayment: If it is found by any State, County, FIND, or independent audit that program funds have not been used in accordance with this rule and applicable laws, the project sponsor shall repay the misused program funds to the

District.

Rulemaking Authority 374.976(2) FS. Law Implemented 374.976(1) FS. History--New 12-17-90, Formerly 16T-2.012, Amended 7-30-02.

66B-2.013 Acknowledgement.

The project sponsor shall erect a permanent sign, approved by the District, at the entrance to the project site which indicates the District's participation in the project. This sign shall contain the FIND logo. In the event that the project sponsor erects a temporary construction sign, this sign shall also recognize the District's participation. If the final product of the project is a report, study or other publication, the District's sponsorship of that publication shall be prominently indicated at the beginning of the publication. If the project results in an educational display, the District's logo and a statement of the District's participation in the project shall be contained in the display.

Rulemaking Authority 374.976(2) FS. Law Implemented 374.976(1) FS. History--New 12-17-90, Formerly 16T-2.013, Amended 2-22-10.

66B-2.014 Small-Scale Spoil Island Restoration and Enhancement Projects.

Proposals shall be accepted for the restoration or enhancement of spoil islands and natural islands within the District's waterways for recreational, navigational, educational, and environmental purposes. The applicable provisions of this rule apply to these applications with the following additions or exceptions:

(1) Application Procedure – A Request for Proposals procedure will be used to request proposals for consideration. Proposals shall follow the format described in FIND Document #03-02, Call for Proposals – Small-Scale Spoil Island Restoration and Enhancement Program (effective date 7-30-02), hereby incorporated by reference and available from the District office. Proposals may be submitted to the District and considered by the Board at any time during the year.

(2) Matching Funds: Small-scale spoil island restoration and enhancement may qualify for up to ninety percent (90%) program funds. The applicant's ten percent (10%) matching funds may include in-kind contribution pursuant to paragraph 66B-2.014(4)(b), F.A.C.

(3) Eligibility: All proposals must meet the following eligibility criteria to be considered for funding:

(a) Management Plan Compliance: Projects shall be in compliance with the provisions of any Spoil Island Management Plans or other management plans that govern the Project site.

(b) Property Control: The Project Sponsor must have written property rights on the Project site to construct and maintain the Project for a minimum of five years. Such property rights can be in the form of a lease, interlocal agreement, use agreement or other legal form approved by the District. The applicant shall include a map clearly delineating the location of all proposed work included in the application.

(4) Funds Allocation: Funds shall be allocated pursuant to Rule 66B-2.005, F.A.C., subject to the exceptions identified in this rule, and with the following additions:

(a) The District shall fund a maximum of up to \$10,000 per project, not to exceed \$30,000 per County, per fiscal year.

(b) The Project Sponsor may contribute in-kind construction labor; such in-kind construction labor costs will be valued at the Independent Sector estimated national value of each volunteer hour. No administrative costs can be incorporated into the Project as Project costs.

(c) The funding provided by the District shall only be allocated for specific Project expenses such as construction materials, trash removal and management, sign installation, plant materials, herbicides, etc. The funding provided by the District shall not be allocated for parties, food or beverages.

Rulemaking Authority 374.976(2) FS. Law Implemented 374.976(1) FS. History--New 7-30-02, Amended 4-24-06, 3-7-11, 3-25-21, 3-11-24.

66B-2.015 Small-Scale Derelict Vessel Removal Projects.

Proposals shall be accepted for financial assistance for the removal of derelict vessels within the District's waterways. The applicable provisions of this rule apply to these applications with the following additions or exceptions:

(1) Application Procedure – Applications shall be submitted on a completed FIND Form No. 05-01 (Small-Scale

Derelict Vessel Removal Program) (effective date 4-24-06), and FIND Form No. 01-06 (Small-Scale Derelict Vessel Removal Program – Project Cost Estimate), (effective date 4-24-06), hereby incorporated by reference and available from the District office. Applications may be submitted to the District and considered by the Board at any time during the year.

(2) The District shall only fund applicants that have identified derelict vessels to be removed and have a current bid for removal for such vessels, or have completed the removal of such vessels within the 6 months preceding the application, subject to eligibility under these program rules.

(3) The program must be sponsored by an eligible government agency or not-for-profit organization.

(4) District funding shall be limited to \$150,000.00 per county, per year, provided on a reimbursement basis only. The limitation on pre-agreement expenses may be waived by the Board in accordance with subsection 66B-2.005(3), F.A.C.

(5) The eligible applicant must provide the remaining matching funds for project completion. In no case shall the District's cost-share contribution exceed 75% of the total project costs. In-house project management or administration costs are not eligible costs or matching costs.

(6) The derelict vessel must be located in the District's Waterways, as defined in Rule 66B-2.003, F.A.C. The applicant shall include a map clearly delineating the location of all vessels included in the application.

(7) The District shall be recognized when possible in all written, audio or video advertising and promotions as a participating sponsor of the program.

(8) The funding provided by the District shall only be allocated for removal of derelict vessels. The District is providing program reimbursement funds only and shall be held harmless with regards to the activities initiated by the applicant.

(9) The applicant shall be responsible for all maintenance, management, disposal and operating expenses associated with the program.

(10) Funds derived from the sale of any derelict vessels or vessel parts removed through this grant program must be reinvested into the applicant's derelict vessel removal program.

(11) The District Board shall make all final decisions concerning the provision of funding for this program.

Rulemaking Authority 374.976(2) FS. Law Implemented 374.976(1) FS. History--New 4-24-06, Amended 4-15-07, 3-25-08, 3-7-11, 1-27-14, 3-25-21, 3-9-23, 3-11-24.

66B-2.016 Waterways Cleanup Events.

Proposals shall be accepted for financial assistance for the organized removal of refuse within the District's waterways. The applicable provisions of this rule apply to these applications with the following additions or exceptions:

(1) Application Procedure: Prior to the event, a request for funding shall be submitted to the District by means of a cover letter detailing the occurrence of the cleanup, contact information, a map of the cleanup locations and the general parameters of the event. In addition, the Applicant will submit a detailed budget clearly delineating the expenditure of all District funds, as well as the overall general budget of the event. Proposals may be submitted to the District and considered by the Board at any time during the year.

(2) Availability: The District shall fund a maximum of one clean-up program per waterway, per year within a county, with exception to the provisions of subsections (8) through (10), below.

(3) Applicant Eligibility: The clean-up program must be sponsored by a government agency or a registered not-for-profit corporation.

(4) Funding: District funding shall be limited to \$5,000 per waterway, per county, except for the provisions of subsections (8) through (10), below.

(5) The District shall be recognized in all written, online, audio or video advertising and promotions as a participating sponsor of the clean-up program.

(6) Funding Eligibility: The funding provided by the District shall only be allocated to reimburse the applicant for out of pocket expenditures related to specific cleanup program expenses such as trash bags, trash collection, haul and landfill fees, gloves, advertising, T-shirts, and related expenses. The funding provided by the District shall not be allocated for parties, meetings, food or beverages.

(7) The District Board shall make all final decisions concerning the provision of funding for a clean-up program. In addition to the requirements stated above, a cleanup program implementing all of the following additional incentives

will qualify for up to additional \$5,000 in clean up funds.

(8) The clean-up program budget must provide equal or greater matching funds for all Navigation District funding.

(9) The applicant shall tally and report the composition and location of the waterway-related debris, with the goal to show definitive progress in the amount of refuse collected, a reduction in the overall debris in the waterway, or an increase in the number of additional waterway areas included in the clean up.

(10) For each additional \$1,000 in Navigation District funding, the applicant shall coordinate a minimum of one waterway collection point or clean up area, or an applicant can conduct an additional waterway cleanup program for the waterway areas.

Rulemaking Authority 374.976(2) FS. Law Implemented 374.976(1) FS. History--New 3-7-11.

EXHIBIT C

FLORIDA INLAND NAVIGATION DISTRICT

ASSISTANCE PROGRAM

Matching Funds Certification

Sponsor: Bal Harbour Village

Project Title: Village Jetty and Cutwalk Segment B Project #: DA-BHV-24-293

Source of Matching Funds: Village budgeted funds

Amount of Matching Funds: \$8,290,000

I hereby certify that the above referenced project Sponsor, as of October 01, ~~2023~~²⁰²⁴, has the required matching funds for the accomplishment of the referenced project in accordance with the Waterways Assistance Program Project Agreement between the Florida Inland Navigation District and the Sponsor, dated _____.*

Project Liaison Name: Kristina Brown

Project Liaison Signature: 

Date: 10/25/2024

*S. 837.06 Florida Statutes, False official statements. - Whoever knowingly makes a false statement in writing with the intent to mislead a public servant in the performance of his or her official duty shall be guilty of a misdemeanor of the second degree, punishable as provided in s. 775.082 or s. 775.083 F.S.

EXHIBIT D

**FLORIDA INLAND NAVIGATION DISTRICT
ASSISTANCE PROGRAM
PAYMENT REIMBURSEMENT REQUEST FORM**

PROJECT NAME: _____ PROJECT #: _____

PROJECT SPONSOR: _____ BILLING #: _____

Amount of Assistance A. _____
 Less Previous Total Disbursements B. _____
 and Less Previous Total Retainage _____
 Held Balance Available = _____

Funds Requested This Disbursement

Funds Requested C. _____
 Less Retainage (-10% unless final) D. _____
 Check Amount = _____

Amount of Assistance _____
 Less Total Prior and Current _____
 Payments Including all retainage _____
 held (B+C) = _____
 = Balance Remaining

SCHEDULE OF EXPENDITURES

Expense Description (Should correspond to Cost Estimate Sheet Categories in Exhibit "A")	Vendor Name and Date	Check No.	Total Cost	Applicant Cost	FIND Cost
---	----------------------	-----------	---------------	-------------------	--------------

EXHIBIT D (CONTINUED)
SCHEDULE OF EXPENDITURES

Expense Description (Should correspond to Cost Estimate Sheet Categories in Exhibit "A")	Vendor Name	Check No. and Date	Total Cost	Applicant Cost	FIND Cost
---	--------------------	-------------------------------	-----------------------	---------------------------	----------------------

Certification for Reimbursement: I certify that the above expenses were necessary and reasonable for the accomplishment of the approved project and that these expenses are in accordance with Exhibit "A" of the Project Agreement. *

Project Liaison

Date

*S. 837.06 Florida Statutes. False official statements. - Whoever knowingly makes a false statement in writing with the intent to mislead a public servant in the performance of his or her official duty shall be guilty of a misdemeanor of the second degree, punishable as provided in s. 775.082 or s. 775.083 F.S.

EXHIBIT E

FLORIDA INLAND NAVIGATION DISTRICT ASSISTANCE PROGRAM

Project Completion Certification

Sponsor: _____

Project Title: _____ Project #: _____

I hereby certify that the above referenced project was completed in accordance with the Assistance Program Project Agreement between the Florida Inland Navigation District and _____, dated _____, 20____, and that all funds were expended in accordance with Exhibit "A" and Paragraph 1 of the Project Agreement. *

Project Liaison Name: _____

Project Liaison Signature: _____

Date: _____

*S. 837.06 Florida Statutes, False official statements. - Whoever knowingly makes a false statement in writing with the intent to mislead a public servant in the performance of his or her official duty shall be guilty of a misdemeanor of the second degree, punishable as provided in s. 775.082 or s. 775.083 F.S.

FIND Form No. 90-13
(Effective Date: 12-17-90, Revised 7-30-02)

EXHIBIT F

**ASSISTANCE PROGRAM PROJECT
QUARTERLY STATUS REPORT**

PROJECT NO. _____

PROJECT TITLE: _____

PROJECT SPONSOR: _____

REPORT PERIOD (Please place an " **X** " in front of the report period and complete the year in the table below.)

___ Oct-Dec 20 ___	___ Jan-Mar 20 ___	___ April-June 20 ___	___ July-Sept 20 ___
Report Due: (Dec 30)	(March 30)	(June 30)	(Sept 30)

WORK ACCOMPLISHED:

PROBLEMS ENCOUNTERED:

PERCENTAGE COMPLETION:

OTHER NOTABLE ITEMS:

Form No. 95-02
(Effective Date: 7-30-02)

EXHIBIT G
ASSISTANCE PROJECT SCHEDULE

OCTOBER 2024-	Project Agreement Executed, Project Initiates.
DECEMBER 30, 2024-	First Quarterly Report Due. - Use Quarterly Status Report Form Exhibit F http://www.aicw.org/assistance_programs/waterway_assistance_programs/index.php
MARCH 30, 2025-	Second Quarterly Report Due.
JUNE 30, 2025-	Third Quarterly Report Due.
SEPTEMBER 30, 2025-	Fourth Quarterly Report Due.
DECEMBER 30, 2025-	Fifth Quarterly Report Due.
MARCH 30, 2026-	Sixth Quarterly Report Due.
JUNE 30, 2026-	Seventh Quarterly Report Due.

NOTE: If the project will not be completed and all close out paperwork submitted by September 30th, a request for a 1-year extension of the completion date of the project should be submitted with the June 2026 quarterly report.

SEPTEMBER 1-30, 2026- Work on Closeout paperwork
Closeout paperwork consists of :

1. Project Completion Certificate, FIND Form No. 90-13 (effective date 7-30-02), which certifies that the project was completed in accordance with the project agreement and the final project plans.
2. A final reimbursement request accompanied by all required supporting documentation including bills and canceled payment vouchers for expenditures.
3. Photograph(s) showing the installation of the sign required by Rule 66B-2.013, F.A.C.
4. Photograph(s) of the completed project clearly showing the program improvements. (jpg or tif format)
5. A Final Project Report (1-2 pages) that shall at minimum include: project name and address, project summary, final cost, and project benefits to the waterway.

SEPTEMBER 30, 2026 - End of Grant. All work must be complete closeout paperwork submitted.
October 2026- finish processing closeout paperwork, perform project inspection and submit final reimbursement check and coordinates check presentation with sponsor.

NOTE: ANY MODIFICATIONS to the PROJECT shall require advance notice and prior written approval of the District. The appropriate timing for modifications to the project cost estimate, Exhibit A, would be after receipt of bids.

***NON-COMPLIANCE by the PROJECT SPONSOR with the reporting schedule in Exhibit G may result in revocation of this agreement pursuant to Section 13 of the project agreement.**

EXHIBIT H

http://www.aicw.org/studies_and_information/bids_files/plans_logos/logos.php#revize_document_center_rz617

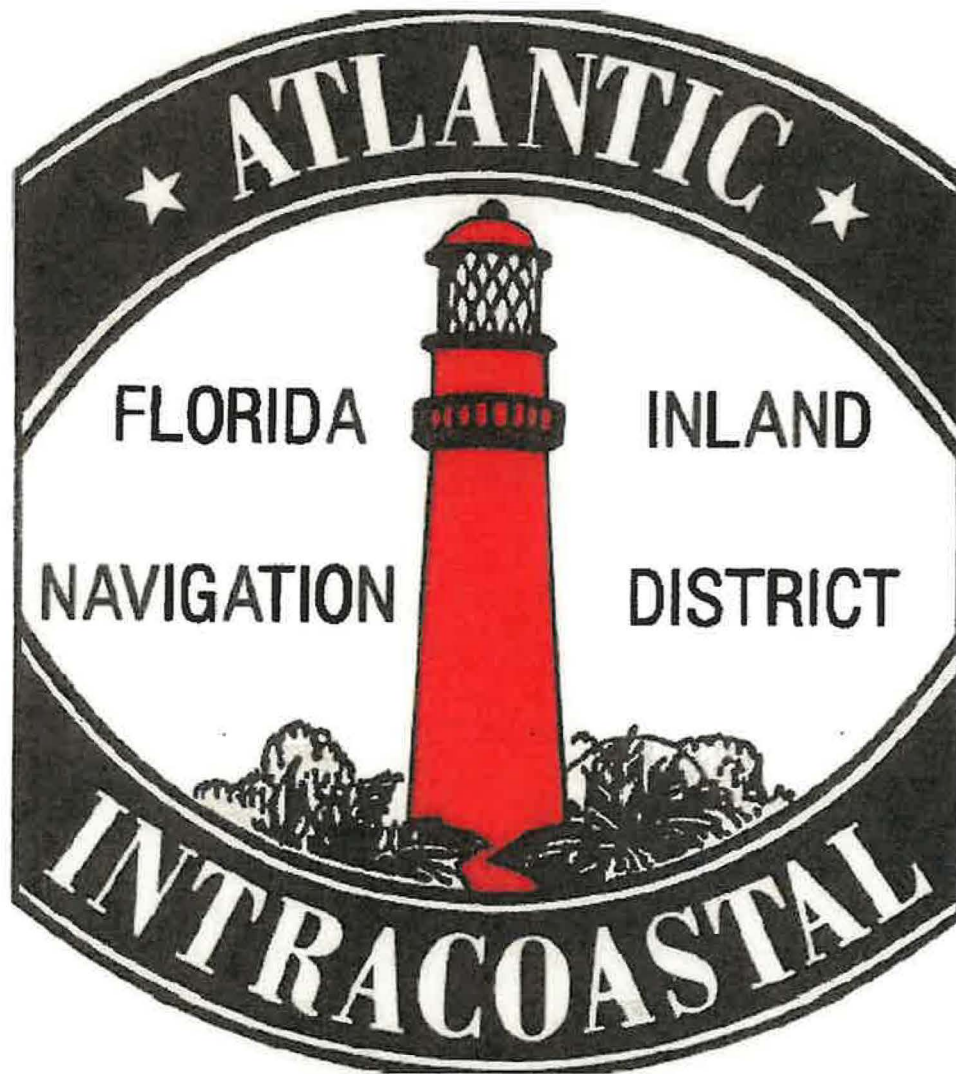

BAL HARBOUR

- V I L L A G E -

COUNCIL ITEM SUMMARY

Condensed Title:

A RESOLUTION OF THE VILLAGE COUNCIL APPROVING ADDITIONAL SERVICES TO THE PROFESSIONAL SERVICES AGREEMENT WITH CHARLES H. BENSON & ASSOCIATES ARCHITECTS FOR THE PROVISION OF ADDITIONAL STRUCTURAL ENGINEERING SERVICES WITH MOFFATT & NICHOL, IN AN AMOUNT NOT TO EXCEED ONE HUNDRED SEVENTY-SEVEN THOUSAND EIGHT HUNDRED DOLLARS (\$177,800).

Issue:

Should the Village Council approve additional services for Moffatt & Nichol for the Harbourfront Park, Jetty & Cutwalk project?

The Bal Harbour Experience:

Beautiful Environment Safety Modernized Public Facilities/Infrastructure
 Destination & Amenities Unique & Elegant Resiliency & Sustainable Community

Item Summary / Recommendation:

This item requests Council approval for additional services from Moffatt & Nichol under the Professional Services Agreement with Charles H. Benson & Associates Architects. These additional services, in an amount not to exceed one hundred seventy-seven thousand, eight hundred dollars (\$177,800), are required to address structural design revisions identified during constructability and value engineering reviews conducted in collaboration with the Construction Manager at Risk (CMAR) firm, their marine sub-contractor and the project team. The revisions will ensure the Harbourfront Park, Jetty & Cutwalk project remain constructable, cost-effective, and compliant with project goals, environmental permits and the FIND and FDEP grant requirements. Approval of this resolution will authorize Moffatt & Nichol to proceed with refining the structural plans and preparing the necessary construction documents to support the CMAR with their Guaranteed Maximum Price (GMP) submission.

Moffatt & Nichol (M&N) has been a critical partner in the Harbourfront Park, Jetty & Cutwalk project, bringing extensive marine and structural engineering expertise to the team. Their prior involvement in significant projects, such as the Bakers Haulover Inlet Management Plan, has demonstrated their ability to deliver innovative, cost-saving solutions in complex marine environments. Their continued involvement is essential to ensure the project progresses efficiently, meets high-quality standards, and aligns with the Village's financial obligations.

THE ADMINISTRATION RECOMMENDS THE APPROVAL OF THIS RESOLUTION.

Financial Information:

	Amount	Account	Account #
	\$177,800	Harbourfront Jetty Capital Outlay - General Fund	01-73-506405

Sign off:

Capital Programs Director	Chief Financial Officer	Village Manager
Matilde E. Reyes, RA	Claudia Dixon	Jorge M. Gonzalez

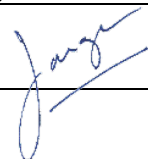

BAL HARBOUR

- VILLAGE -

COUNCIL MEMORANDUM

TO: Honorable Mayor and Village Council

FROM: Jorge M. Gonzalez, Village Manager

DATE: November 19, 2024

SUBJECT: **A RESOLUTION OF THE VILLAGE COUNCIL OF BAL HARBOUR VILLAGE, FLORIDA; APPROVING ADDITIONAL SERVICES TO THE PROFESSIONAL SERVICES AGREEMENT WITH CHARLES H. BENSON & ASSOCIATES ARCHITECTS FOR THE PROVISION OF ADDITIONAL STRUCTURAL ENGINEERING SERVICES WITH MOFFATT & NICHOL, IN AN AMOUNT NOT TO EXCEED ONE HUNDRED SEVENTY-SEVEN THOUSAND EIGHT HUNDRED DOLLARS (\$177,800); PROVIDING FOR IMPLEMENTATION; PROVIDING FOR AN EFFECTIVE DATE.**

ADMINISTRATIVE RECOMMENDATION

I am recommending approval of this Resolution.

BACKGROUND

On October 22, 2018, Bal Harbour Village issued Request for Qualifications (RFQ) No. 2018-03 for landscape architecture services for the Harbourfront Park, Jetty & Cutwalk project.

On March 19, 2019, the Village Council awarded the RFQ to Mikyoung Kim Design (MYKD), whose proposal was deemed in the best interest of the Village. MYKD was contracted on May 21, 2019, under Resolution No. 2019-1225, to lead the landscape architecture and engineering services for the project.

During their contract, MYKD successfully completed the schematic design and advanced the design development phase. By early 2024, the project had achieved partial design development with several environmental permits secured. However, as the project progressed, it became evident that, according to Florida Statutes 481.301 and 481.303, MYKD, as a landscape architecture firm, could not submit for permits due to the project's extensive structural components. In compliance with these statutes, the Village determined that a licensed Florida architect must lead the project to oversee the completion of Construction Documents for solicitation of Village Building Department and Miami Dade County permits and ensure compliance with the conditions of the environmental agencies' requirements.

On July 16, 2024, the Village Council approved the transfer of MYKD's contractual obligations to Charles H. Benson & Associates Architects (CBA) under an Assignment of Agreement. This ensured that the project remained compliant with the statutes while

allowing MYKD to continue serving as the lead designer. CBA now oversees the A/E project team, with Moffatt & Nichol (M&N), continuing their role as structural engineers within that project team.

In September 2024, the Village contracted The Whiting-Turner Contracting Company (WT) as the Construction Manager at Risk firm (CMAR) for the Harbourfront Park, Jetty & Cutwalk project. Since then, multiple meetings have been held in August, September and October between M&N, the CMAR, CBA, and the Village to discuss constructability, value engineering, and alignment with the requirements of the recently awarded FDEP (\$8 million) and FIND (\$3 million) grants.

ANALYSIS

The addition of WT as the CMAR has brought valuable insights during their preconstruction phase of the Harbourfront Park, Jetty & Cutwalk project. Their role is central in helping the Village explore constructability and value engineering options to optimize the project's design, delivery date and reduction of construction cost. Through collaboration between the CMAR, CBA, M&N, and the Village, the team has been able to dive deeper into the work previously advanced by MYKD. This collaborative approach ensures that the project benefits from practical, cost-saving strategies while maintaining its design integrity.

During recent team meetings and site walkthroughs with the CMAR and Ebsary, the marine subcontractor, several key constructability matters were identified. These include potential conflicts between the cantilevered platform beams and existing underground utilities, deep injection wells, and planters. Additionally, the investigative work on the existing seawall tiebacks, the cantilever length of the scalloped platforms on the beach side, and the structural reconfiguration of the jetty's walking surface raised the need for structural plan modifications. We also discussed the sequencing of the construction because the site is very narrow. The solutions discussed identified the need for site built structural components allowing for implementing the construction sequencing starting at the tip and backtracking towards the west. This solution will not require waterside construction via a barge or with over the water trestles. As a result, M&N's scope of work will increase over the coming months to address these structural changes and ensure the project remains both cost-effective and constructible.

Moffatt & Nichol, a firm with an excellent reputation for marine and structural engineering, was brought on board to replace the original structural engineer and has been integral to the project's progress. They have already demonstrated their expertise through their involvement in the Bakers Haulover Inlet Management Plan and their alternative design approaches for the Jetty & Cutwalk project, which included cost-saving solutions such as constructing certain elements from the landside rather than the waterside to improve storm surge survivability.

Now, with the additional insights from the CMAR, M&N will need to revise the structural plans further, incorporating the adjustments discussed in recent meetings. This includes

refining the foundation packages, updating the structural designs for the jetty, seawall and ensuring that key elements such as the living shoreline and scalloped platforms align with both design goals, grant requirements and budgetary constraints.

To ensure that the Village can proceed with the most cost-efficient and structurally sound design, additional services from M&N are required. These services will enable M&N to collaborate with the project team in revising the design development phase, preparing construction documents, and supporting the CMAR in generating a Guaranteed Maximum Price (GMP) for the project. Their continued involvement is essential to delivering a high-quality project that aligns with both the Village's expectations and the recently awarded grants that make up approximately 50% of the estimated project costs.

Approval of these additional services will ensure the timely progression of the project, with constructable construction documents that are aligned with the Village's financial and design goals while ensuring that the project remains on track for its upcoming construction phase.

THE BAL HARBOUR EXPERIENCE

The Harbourfront Park, Jetty & Cutwalk project is integral to the Village's vision of creating a resilient, safe, and visually stunning environment for residents and visitors. The collaboration between Charles H. Benson & Associates Architects, Moffatt & Nichol, and Whiting-Turner as the Construction Manager at Risk ensures that every element of the project is aligned with Bal Harbour's high standards of design, construction, and sustainability. The project will enhance key community spaces, offering both beauty and utility while prioritizing long-term resilience and modernized infrastructure.

This project aligns with Bal Harbour's broader goals to:

- *Strengthen community resilience and sustainable design.*
- *Elevate public safety by improving infrastructure.*
- *Enhance amenities and destination appeal.*
- *Deliver modernized public facilities that cater to both residents and visitors.*
- *Uphold exclusivity and access to Bal Harbour's unique environment.*
- *Create a beautiful, functional environment that blends with the Village's overall aesthetic.*

As the project progresses, the Village's commitment to ensuring quality and maintaining the "Bal Harbour Experience" will be reflected in every design decision, structural adjustment, and construction phase.

CONCLUSION

I recommend the approval of the Resolution to authorize additional services for Moffatt & Nichol (M&N) under the professional services agreement led by Charles H. Benson & Associates Architects for the Harbourfront Park, Jetty & Cutwalk project. These additional services, in an amount not to exceed one hundred seventy-seven thousand, eight hundred

dollars (\$177,800), are essential for addressing key constructability and value engineering solutions identified during recent site reviews and ensuring the project progresses efficiently while maintaining cost-effectiveness.

M&N's continued involvement will ensure that the structural plans are refined to meet the Village's high standards, aligning with both financial goals and grant requirements. Their expertise, combined with the collaborative efforts of the CMAR and the Village, will ensure that the Harbourfront Park, Jetty & Cutwalk project continues to embody the values of resilience, beauty, and safety that define the *Bal Harbour Experience*.

Council's approval of this Resolution will help support the Village with ensuring the project remains on schedule and within budget while delivering the modernized and sustainable public facilities envisioned for the community.

Attachments:

1. Exhibit A - Moffatt & Nichol - Additional Services Fee Proposal

RESOLUTION NO. 2024-____

A RESOLUTION OF THE VILLAGE COUNCIL OF BAL HARBOUR VILLAGE, FLORIDA; APPROVING ADDITIONAL SERVICES TO THE PROFESSIONAL SERVICES AGREEMENT WITH CHARLES H. BENSON & ASSOCIATES ARCHITECTS FOR THE PROVISION OF ADDITIONAL STRUCTURAL ENGINEERING SERVICES WITH MOFFATT & NICHOL, IN AN AMOUNT NOT TO EXCEED ONE HUNDRED SEVENTY-SEVEN THOUSAND EIGHT HUNDRED DOLLARS (\$177,800); PROVIDING FOR IMPLEMENTATION; PROVIDING FOR AN EFFECTIVE DATE.

WHEREAS, Moffatt & Nichol (M&N) was retained as the structural engineering subconsultant for the Harbourfront Park, Jetty & Cutwalk Project (the "Project") and has provided critical expertise in marine and structural design throughout the Project; and

WHEREAS, following the reassignment of M&N's structural engineering services from Mikyoung Kim Design (MYKD) to Charles H. Benson & Associates Architects ("Benson") in October 2024, M&N has continued to play a pivotal role in advancing the Project's structural design; and

WHEREAS, the Village has engaged The Whiting-Turner Contracting Company, as the Construction Manager at Risk (CMAR) for the Project, and recent constructability and value engineering reviews have identified necessary structural design revisions to address construction efficiencies and cost savings for the Project; and

WHEREAS, additional services from M&N are required to refine the structural plans and develop revised contract documents, ensuring that the Project remains constructable, cost-effective, and compliant with both Project goals and grant requirements; and

WHEREAS, the Village Council has determined that it is in the best interest of the Village to approve these structural engineering additional services in an amount not to exceed \$177,800 to ensure the timely progression of the Project and alignment with financial and structural objectives.

NOW, THEREFORE, BE IT RESOLVED BY THE VILLAGE COUNCIL OF BAL HARBOUR VILLAGE, FLORIDA, AS FOLLOWS:

Section 1. Recitals Adopted. That the above stated recitals are hereby adopted and confirmed.

Section 2. Approval of Additional Services. That the additional structural engineering services by Moffatt & Nichol, under the Professional Services Agreement with Charles H. Benson & Associates Architects, in an amount not to exceed one hundred seventy-seven thousand, eight hundred dollars (\$177,800), are hereby approved, and the Village Manager is authorized to execute any necessary documents on behalf of the Village.

Section 3. Implementation. That the Village Manager is hereby authorized to take all actions necessary to implement the additional services and the purposes of this Resolution.

Section 4. Effective Date. That this Resolution shall take effect immediately upon the adoption hereof.

PASSED AND ADOPTED this 19th day of November, 2024.



Mayor Jeffrey P. Freimark

ATTEST:

Dwight S. Danie, Village Clerk

APPROVED AS TO FORM AND LEGAL SUFFICIENCY:

Village Attorney
Weiss Serota Helfman Cole & Bierman P.L.



3150 SW 38thth Avenue, Suite 1050
Miami, Florida 33146
305-230-1924
www.moffattnichol.com

November 8, 2024

201960-A4

Village of Bal Harbour

655 96th Street
Bal Harbour, FL 33154

Attn: Ms. Mattie Reyes, Capital Program Director

RE: Marine Engineering Services for the Bal Harbour Cutwalk and Jetty, Village of Bal Harbour, Florida

Dear Mattie:

Moffatt & Nichol (M&N) has compiled this letter proposal to summarize the background and next steps relative to the Bal Harbour Cutwalk and Jetty Project (Project) located in the Village of Bal Harbour (Village), Miami-Dade County, Florida. The letter is organized with the background, Fee Budget Summary, and Next Steps relative to the Project. The remainder of the letter is the scope of services to complete the marine engineering components of the Project.

Background

M&N was retained by the prime consultant for the Project, Mikyoung Kim Design (MYKD), to provide marine engineering services for the Project as outlined in the agreement for services dated September 24, 2021 (revised April 1, 2022). M&N worked as part of the architectural/engineering (A/E) team to complete the marine works engineering design and support the environmental permitting through the local, state and federal regulatory agencies with jurisdiction. The A/E drawing packages were compiled by other consultants, and due to the complexities of the Project implementation and the overall schedule, the Village retained a Construction Manager at Risk (CMAR) to deliver the Project. The CMAR has completed initial construction budgets, and based on their review there needs to be substantial cost reductions, in the order of \$6M - \$7M, to reduce the Project scope and complexity to meet budget and funding grant constraints. Value engineering (VE) options have been discussed and circulated during a series of meetings with the CMAR that will reduce costs and risk to the marine works construction. In addition, the Village retained an architect, Charles H Benson and Associates (Benson), in August, 2024 to take over the prime consultant responsibility from MYKD. Benson will lead the A/E team to redesign the Project to meet the budget constraints and to maintain as much of the Project vision and programming as originally provided by MYKD. In addition, Benson will be responsible for preparing coordinated construction documents for the CMAR. The CMAR project delivery also facilitates early contractor involvement (ECI) to encourage reviews of progress sets of drawings relative to budget constraints and to provide feedback on constructability. Based on initial reviews of the drawing sets to date, the CMAR has outlined several alternative design approaches that the Village is reviewing in an effort to reduce the Project budget, and M&N will need to work with the A/E team to refine the marine structural design after Benson provides updated base files that modify the Project design and programming.

M&N Fee Budget Summary

M&N has reviewed accounting and Project files to date, and the last invoice submitted to MYKD under

that agreement was for work completed through May 31, 2024. Three tasks were not fully billed pending completion of design tasks, and M&N has not invoiced for the following tasks with remaining budgets:

- Task 8: \$8265
- Task 10: \$5475
- Task 12: \$2551.70

Total Unbilled: \$16,291.70

Upon review and approval of this updated scope of services, this remaining budget will be applied by the Village. M&N will terminate the existing agreement with MYKD.

Scope of Services

Based on the meetings over the past two months with Benson, the Village, and the CMAR, M&N has compiled this scope of services with work tasks numbered sequentially from the previous work orders under contract with MYKD.

Part 13 – Marine Structural Design – Additional Services

The Village has requested structural design modifications to eliminate specialty engineering requirements during construction. M&N and Benson have coordinated on scope items that require additional structural design services that were not scoped in the original scope of services. M&N will complete the structural design for the modifications and additional detailing for the components in the below table. The construction drawings will be updated and additional sheets compiled as needed for the detailing associated with these elements. The structural calculations will also be updated and/or modified.

*Deliverables: Design Development and Construction Drawings for the Components (a-k)
 Structural Calculations*

a	Provide details on wood decking connections including framing	\$7,100
b	Provide details on railing and associated connections to platform concrete, including removable railings	\$6,700
c	Provide structural connections detail of flood gate to seawall. (fabricator design assist)	\$2,900
d	Provide connection details for grating, including removable grating	\$4,800
e	Provide details at existing jetty edge	\$4,000
f	Provide Canopy design including guard rail connections	\$5,700
g	Provide details on wood cladding on edge of platforms	\$5,400
h	Provide details for stairs on platforms	\$3,400
i	Provide details for ramps on platforms	\$2,900
j	Provide connection details for custom wood benches	\$6,200
k	Provide railing and connection design/details for beach steps	\$2,300

Fees for Part 13 services are lump sum at..... \$51,400

Part 14 – Additional Technical Specifications

M&N will prepare and compile additional technical specifications, using the UFGS templates, for the additional structural materials and components as outlined in Part 13 services. These additional specifications will be incorporated into the Project technical specifications.

Deliverables: Additional Technical Specifications (UFGS format, PDF)

Fees for Part 14 services are lump sum at..... \$4,900

Part 15 - Segment A – Marine Structural Refinement

During workshops in August, the CMAR working with M&N developed an alternative marine structural configuration for Segment A which is the section of the Project from the beach west. This component of the Project is primarily a sheet pile configuration replacement seawall along sections of overwater decking. The Project team worked closely to maintain the original programming, and the marine foundation modifications will be primarily underground and not visible from the finished Cutwalk. The refinements consist of the following (see below sketch):

- Raise the support cap above the water table; this revision accounts for the realignment of tree planters by the landscape architect for locations between pile bent caps
- Modify the anchor pocket and sleeve structural connection detailing
- Modify the precast beam to reduce the crane pick load
- Change to domestic combi-wall sheet piling (to meet grant requirements)
- Adjust spacing and pile bent configuration for the combi-wall sheet piling; modify plan and pile bent spacing

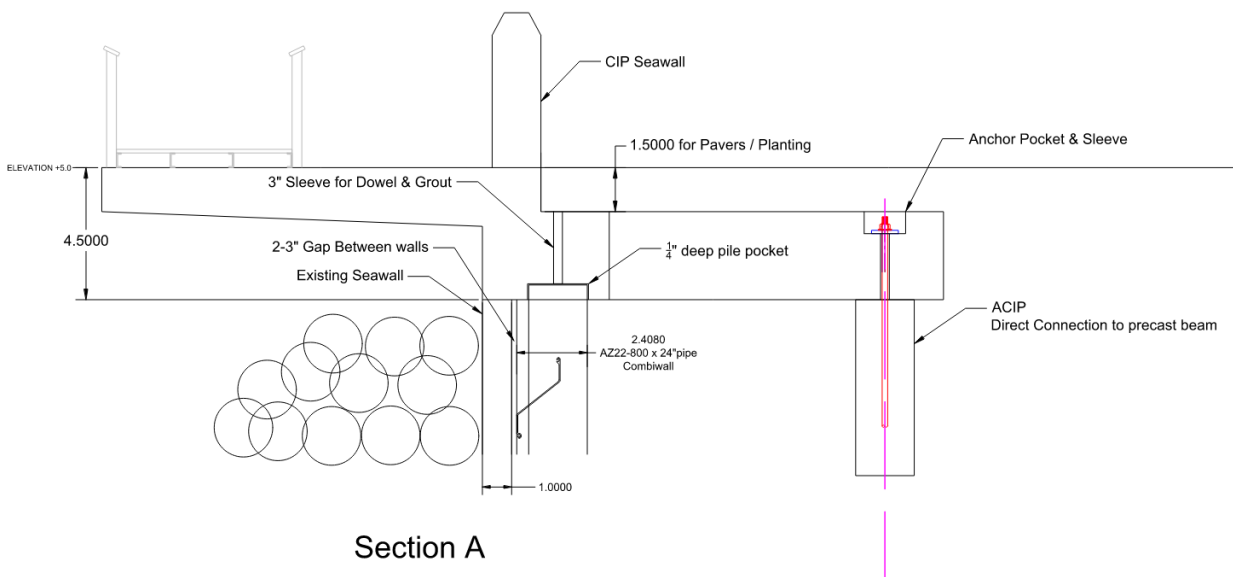

This Segment A will be compiled as a “foundation set” of drawings to facilitate ordering of long lead time materials, and this marine works component of the Project will also be utilized to meet the grant

deadlines. Under Part 12 services of the previous agreement, the marine works drawings were separated, and this set of Segment A drawings will remain separate to facilitate the building permit processing. The engineering design will be refined, and updated engineering calculations prepared along with construction drawings that will be coordinated with Benson. Two deliverables will be compiled; one at Design Development (DD) and the other at Construction Document (CD) level of completion for review by the CMAR and by the Village. The CMAR will provide an updated construction budget at the DD level of design to ensure no further redesign or reduction in scope is required.

*Deliverables: Design Development and Construction Drawings for Segment A
Structural Calculations*

Fees for Part 15 services are lump sum at..... \$27,000

Part 16 - Segment B – Marine Structural Refinement

During the meetings in August at the Village with Benson and the CMAR, significant design revisions were developed to reduce costs and to facilitate constructability over the previous designs developed for the jetty components of the Project. The design developed by MYKD had extensive cantilevered sections of deck over water that would be subject to high coastal engineering loads. The design had complexities that did not warrant any repetition or efficient methods for construction. The marine foundation system of the jetty represents a large portion of the overall construction budget. The CMAR and M&N developed the typical cross section that reduces the overall finished grade elevations and jetty footprint. The design also “standardizes” the construction method while accommodating the Project programming in the cast-in-place topping slab. See below sketch.

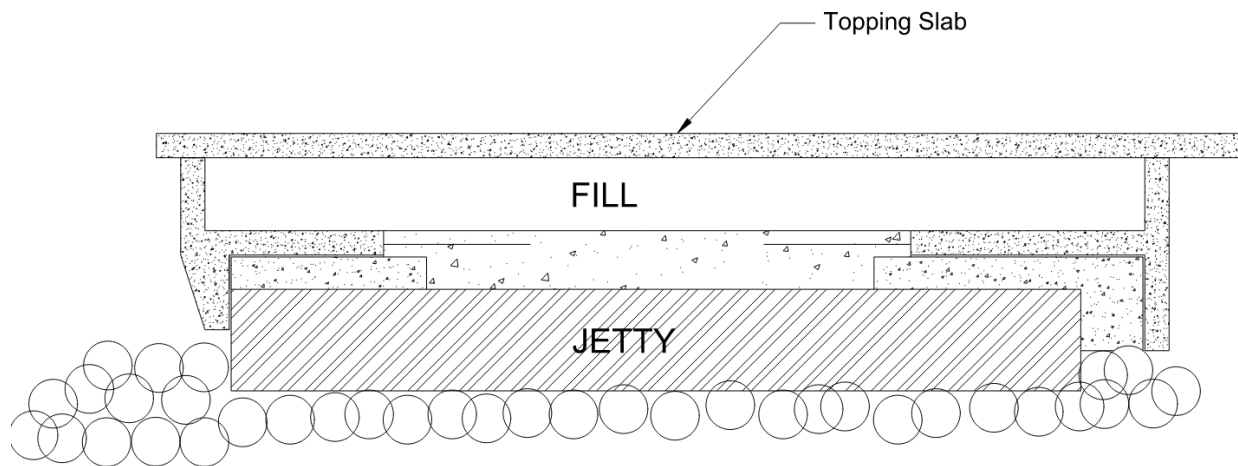

This design concept will require a complete redesign, and Benson will provide updated base files with the overall Project footprint and updated finished grade elevations. The previous design accommodated precast elements to the extent possible, however this design approach facilitates the “top down” approach with equipment working from on top the jetty. M&N’s responsibility will be for the marine foundation systems to the topping slab (based on finished grade elevations established by Benson). Benson and the A/E team will be responsible for the landscape and hardscape elements of the Project

from the concrete slab “up” that would include all Mechanical/Electrical/Plumbing (MEP) as well as site/civil engineering. M&N will coordinate the design with Benson.

Components of the jetty were modified throughout the permitting process with the U.S. Army Corps of Engineers as part of the formal Section 404 review process. These elements, such as the concrete cap geometry for wave deflection, etc. will need to remain in the design so as to remain in compliance with the permitted design.

The CMAR will provide an updated construction budget at the DD level of design to ensure no further redesign or reduction in scope is required.

*Deliverables: Design Development and Construction Drawings for Segment B
Structural Calculations*

Fees for Part 16 services are lump sum at \$71,000

Part 17 – Progress Meetings

M&N will participate in bi-weekly progress meetings, anticipated to be conducted virtually. Depending on the meeting agenda, 1-2 engineers from M&N will participate through the design coordination with Benson, the CMAR, and the A/E team. Over the estimated 6-month period for this design refinement of both Segments A and B, M&N anticipates attending approximately twenty (20) meetings. Each meeting is anticipated to be between 1-2 hours. M&N has already participated in several Project meetings since June, 2024.

Fees for Part 17 services are lump sum \$21,000

Part 18 – Building Permit Processing Support

M&N will coordinate with the CMAR and Village and provide technical consulting support during the Village building permit processing of the Segment A foundation permit drawings. Approximately fifteen (15) hours of consulting support is anticipated that would include addressing building permit department comments. The Village will be advised if additional budget is required for any reason. The CMAR will be responsible for expediting and processing the building permit.

Fees for Part 18 services are lump sum \$2,500

Schedule

Part 15 – completed within 2 months of Notice to Proceed

Part 16 – will commence concurrent with Part 15, and will be completed within 4 months of NTP

Parts 13 and 14 services – completed concurrently with Part 16 services

Parts 17 and 18 – concurrent with Parts 15 and 16 services

A formal schedule will be compiled with more detailed tasks and milestones upon authorization of the scope of services.

GENERAL

Environmental Permitting

Services are excluded and will be provided by others on the A/E team.

Construction Administration

M&N will compile a separate scope of services to provide construction administration once updated Project schedules are compiled by the CMAR. Components of Segment A may be initiated for construction while design is still progressing for Segment B.

Contract

Based on discussions with the Village, M&N understands the Village will assign a prime consulting agreement in the same format and with the same terms as the agreement utilized for MYKD. M&N has reviewed this agreement in the past, and the subconsultant agreement between MYKD and M&N referenced the prime agreement with the Village. This scope of services is subject to this assigned contract with mutually agreed upon terms.

Payment

M&N will invoice the Village each month on a percent complete basis for lump sum tasks. Expenses will be invoiced separately at cost. Payment is in U.S. dollars, and ACH payment/wire transfer information can be provided. Moffatt & Nichol will stop work if any undisputed invoice is more than 30 days past due, unless arrangements are made in advance with management.

We look forward to continuing the working relationship with the Village of Bal Harbour. Should you have any questions regarding this proposal, please do not hesitate to contact Tim Blankenship, P.E., at 786-725-4180 or tblankenship@moffattnichol.com.

Sincerely,

Moffatt & Nichol, Inc.



T. K. Blankenship, PE
Vice President

TKB:kt

BAL HARBOUR

- VILLAGE -

COUNCIL ITEM SUMMARY

Condensed Title:

A RESOLUTION OF THE VILLAGE COUNCIL OF BAL HARBOUR VILLAGE, FLORIDA, AUTHORIZING BAL HARBOUR VILLAGE TO ACT AS THE FISCAL AGENT FOR ALL SUBCONSULTANT ARCHITECTURE AND ENGINEERING AGREEMENTS ASSOCIATED WITH THE HARBOURFRONT PARK, JETTY, AND CUTWALK PROJECT; AUTHORIZING THE VILLAGE MANAGER TO EXECUTE ADDENDUMS AS FISCAL AGENT TO THE SUBCONSULTANT CONTRACTS FOR SERVICES AS REQUIRED BY CHARLES H. BENSON & ASSOCIATES, ARCHITECTS, P.A.

Issue:

Should the Village Council approve the authorization for Bal Harbour Village to act as the fiscal agent for subconsultant agreements associated with the Harbourfront Park, Jetty, and Cutwalk Project, and authorize the Village Manager to execute necessary addendums to formalize this role?

The Bal Harbour Experience:

- | | | |
|---|--|---|
| <input checked="" type="checkbox"/> Beautiful Environment | <input checked="" type="checkbox"/> Safety | <input checked="" type="checkbox"/> Modernized Public Facilities/Infrastructure |
| <input checked="" type="checkbox"/> Destination & Amenities | <input checked="" type="checkbox"/> Unique & Elegant | <input checked="" type="checkbox"/> Resiliency & Sustainable Community |

Item Summary / Recommendation:

This item requests Council approval for Bal Harbour Village to assume the role of fiscal agent for subconsultant architecture and engineering agreements associated with the Harbourfront Park, Jetty, and Cutwalk Project. This authorization includes permitting the Village Manager to execute addendums that formalize the Village's fiscal oversight and payment processing for subconsultants, following the assignment of project responsibilities from Mikyoung Kim Design (MYKD) to Charles H. Benson & Associates, Architects, P.A. By acting as fiscal agent, the Village ensures timely payments to subconsultants and maintains a clear financial management structure. Approval of this item will support seamless project continuity, uphold financial accountability, and reinforce the Village's commitment to the efficient execution of public projects. It is recommended that the Council approve this resolution to support effective financial management and continuity for the Harbourfront Park, Jetty, and Cutwalk Project.

THE ADMINISTRATION RECOMMENDS APPROVAL OF THIS RESOLUTION.

Financial Information:

	Amount	Account	Account #
	X	X	X

Sign off:

Capital Programs Director	Chief Financial Officer	Village Manager
Matilde E. Reyes, RA	Claudia Dixon	Jorge M. Gonzalez

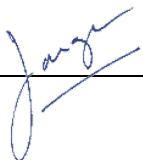

BAL HARBOUR

- VILLAGE -

COUNCIL MEMORANDUM

TO: Honorable Mayor and Village Council

FROM: Jorge M. Gonzalez, Village Manager 

DATE: November 19, 2024

SUBJECT: **A RESOLUTION OF THE VILLAGE COUNCIL OF BAL HARBOUR VILLAGE, FLORIDA, AUTHORIZING BAL HARBOUR VILLAGE TO ACT AS THE FISCAL AGENT FOR ALL SUBCONSULTANT ARCHITECTURE AND ENGINEERING AGREEMENTS ASSOCIATED WITH THE HARBOURFRONT PARK, JETTY, AND CUTWALK PROJECT; AUTHORIZING THE VILLAGE MANAGER TO EXECUTE ADDENDUMS AS FISCAL AGENT TO THE SUBCONSULTANT CONTRACTS FOR SERVICES AS REQUIRED BY CHARLES H. BENSON & ASSOCIATES, ARCHITECTS, P.A., FOLLOWING THE ASSIGNMENT OF SERVICES FROM MIKYOUNG KIM DESIGN; PROVIDING FOR IMPLEMENTATION; AND PROVIDING FOR AN EFFECTIVE DATE.**

ADMINISTRATIVE RECOMMENDATION

I am recommending approval of this Resolution.

BACKGROUND

On May 21, 2019, Bal Harbour Village entered into a Professional Services Agreement with Mikyoung Kim Design (MYKD) for landscape architecture and engineering services related to the Harbourfront Park, Jetty, and Cutwalk project. MYKD engaged several subconsultants to provide essential architectural and engineering (A&E) services for the Project.

As of July 17, 2024, the Village, MYKD, and Charles H. Benson & Associates Architects, P.A. (Benson) executed an Assignment of Agreement (attached), transferring MYKD's responsibilities for architectural design and construction administration to Benson. On August 9, 2024, this role was formalized through a 2024 Master Owner-Architect Professional Services Agreement with Benson, establishing Benson as the Architect of Record with oversight of all MYKD-engaged subconsultants.

To support this transition, Benson will retain each original subconsultant under an addendum to the existing contracts, designating Bal Harbour Village as the fiscal agent. As the fiscal agent, the Village will facilitate direct payment processing to subconsultants on behalf of Benson, ensuring continuity and timeliness in managing financial obligations for the Project.

ANALYSIS

The addendum includes multiple provisions to ensure clarity in responsibilities, fiscal oversight, and streamlined project continuity. The addendum's primary purpose extends beyond establishing Bal Harbour Village as the fiscal agent; it also formalizes the official retention of each subconsultant by Benson under the original MYKD contract terms. This retention is achieved through the addendum's clause specifying that Benson, now the Architect of Record, has assumed all responsibilities related to subconsultant services for the Harbourfront Park, Jetty, and Cutwalk project. By preserving the initial scope of services and enabling mutually agreed modifications as needed, the addendum solidifies Benson's authority to oversee subconsultant work, ensuring a cohesive approach to project continuity and accountability.

Through its fiscal agent role, the Village supports this transition by managing direct payments, streamlining financial administration, and providing clear boundaries around payment responsibilities. The waiver of claim clause protects the Village from past financial liabilities while offering subconsultants a formal process to address any unpaid work directly with the Village. This provision strengthens transparency and clarity for all parties involved, eliminating ambiguity regarding financial responsibilities.

The addendum also incorporates a structured "Status Reporting Requirement," which mandates that subconsultants submit a comprehensive update on completed work and any unresolved issues from their previous agreements with MYKD. This reporting mechanism allows the Village and Benson to gain a thorough understanding of the Project's current state, ensuring that no critical details are overlooked in the transition to Benson's management.

Furthermore, the future invoicing framework in the addendum outlines a clear process for submitting, approving, and disbursing payments. By requiring all invoices to be reviewed by both Benson and the Village, the addendum ensures that each payment is analyzed for accuracy and alignment with the Project's financial framework. Collectively, these provisions establish an integrated approach that maintains project integrity, upholds financial accountability, and facilitates seamless coordination between the Village, Benson, and subconsultants.

The Resolution authorizes Bal Harbour Village to act as the fiscal agent for all subconsultant agreements associated with the Harbourfront Park, Cutwalk, and Jetty project, empowering the Village Manager to execute necessary addendums to facilitate this role. By approving this Resolution, the Village Council formalizes the Village's responsibilities in managing direct payments to subconsultants, ensuring financial continuity and accountability throughout the project. Additionally, the resolution affirms Benson's authority to retain and oversee subconsultants under the original MYKD contract terms, solidifying the project management structure.

THE BAL HARBOUR EXPERIENCE

By assuming the role of fiscal agent for subconsultant agreements, Bal Harbour Village reinforces its commitment to project accountability and transparency. This role ensures timely payments to subconsultants, which supports the Village's objective of delivering high-quality public projects efficiently. In doing so, the Village enhances the overall Bal Harbour Experience, demonstrating its dedication to excellent public amenities, responsible financial stewardship, and well-managed project oversight.

CONCLUSION

Based on my review, I am seeking Council approval of this resolution, which authorizes the Village Manager to execute addendums as fiscal agent for all subconsultant architecture and engineering agreements associated with the Harbourfront Park, Jetty, and Cutwalk project. This authorization enables Bal Harbour Village to act as fiscal agent for subconsultant contracts, ensuring streamlined payment processing and maintaining project oversight. Formalizing this role aligns with our commitment to responsible financial management and project accountability. I recommend approval of this item to support efficient financial administration and uphold the Village's dedication to high standards in managing and delivering public projects.

Attachment:

1. Assignment of Agreement - Charles Benson and Associates Executed
2. Exhibit A - Draft Template for Addendum to Subconsultant Contract for Services Attachment - executed Assignment of Agreement

RESOLUTION NO. 2024-____

A RESOLUTION OF THE VILLAGE COUNCIL OF BAL HARBOUR VILLAGE, FLORIDA, AUTHORIZING BAL HARBOUR VILLAGE TO ACT AS THE FISCAL AGENT FOR ALL SUBCONSULTANT ARCHITECTURE AND ENGINEERING AGREEMENTS ASSOCIATED WITH THE HARBOURFRONT PARK, JETTY, AND CUTWALK PROJECT; AUTHORIZING THE VILLAGE MANAGER TO EXECUTE ADDENDUMS AS FISCAL AGENT TO THE SUBCONSULTANT CONTRACTS FOR SERVICES AS REQUIRED BY CHARLES H. BENSON & ASSOCIATES, ARCHITECTS, P.A., FOLLOWING THE ASSIGNMENT OF SERVICES FROM MIKYOUNG KIM DESIGN; PROVIDING FOR IMPLEMENTATION; AND PROVIDING FOR AN EFFECTIVE DATE.

WHEREAS, on May 21, 2019, Bal Harbour Village (the "Village") entered into a Professional Services Agreement with Mikyoung Kim Design ("MYKD") for landscape architecture and engineering services for the Harbourfront Park, Cutwalk, and Jetty project ("Project"); and

WHEREAS, MYKD retained several subconsultants to provide specific architecture and engineering services for the Project; and

WHEREAS, on July 17, 2024, the Village, MYKD, and Charles H. Benson & Associates, Architects, P.A. ("Benson") executed an Assignment of Agreement, transferring MYKD's responsibilities under the existing professional services agreement to Benson, who is now responsible for providing architectural design and construction administration services for the Project; and

WHEREAS, on August 9, 2024, the Village entered into the 2024 Master Owner-Architect Professional Services Agreement with Benson to formalize Benson's role as the Architect of Record, including oversight of all architecture and engineering (A&E) subconsultants previously retained by MYKD; and

WHEREAS, as part of this transition, Benson intends to retain the services of each subconsultant through an Addendum (Exhibit "A") to the original subconsultant agreements, which incorporates terms specifying the Village's role as fiscal agent to facilitate direct payment processing to subconsultants on behalf of Benson; and

WHEREAS, any future agreements executed by Benson with additional subconsultants for the Project shall include language specifying that the Village will continue to serve as the fiscal agent; and

WHEREAS, the Village’s involvement in these agreements and addendums is limited to its fiscal agent role, ensuring timely and direct payment to subconsultants and incorporating provisions that outline the Village’s oversight responsibilities as project owner; and

WHEREAS, the Village Council finds that acting as the fiscal agent for all subconsultant A&E agreements for the Project, including processing payments and maintaining oversight, is in the best interest of the Village and supports the Project’s objectives.

NOW, THEREFORE, BE IT RESOLVED BY THE VILLAGE COUNCIL OF BAL HARBOUR VILLAGE, FLORIDA, AS FOLLOWS:

Section 1. Recitals Adopted. That the above recitals are hereby adopted and confirmed as true and correct and are incorporated herein by this reference.

Section 2. Authorization of Fiscal Agent Role. That the Village is hereby authorized to act as the fiscal agent specifically for all subconsultant architecture and engineering agreements associated with the Harbourfront Park, Jetty, and Cutwalk Project, processing direct payments to subconsultants in accordance with the terms of the Addendums to the Subconsultant Contracts for Services and/or future Subconsultant Contracts for Services prepared by Benson.

Section 3. Authorization for Village Manager to Execute Addendums as Fiscal Agent. That the Village Manager is hereby authorized to execute, on behalf of the Village, all necessary Addendums to the Subconsultant Contracts for Services as fiscal agent, as required by Benson for the continuation of the Project. This authority includes signing addendums that outline the Village’s role in payment processing, as well as communication, oversight, and reporting requirements involving the Village.

Section 4. Implementation. That the Village Manager, or his designee, is hereby authorized to take all necessary actions to implement this Resolution, including

coordinating with Benson and subconsultants on payment processing, communication, and oversight requirements as outlined in the Addendums and future Subconsultant Contracts for Services related to the Project.

Section 5. Effective Date. That this Resolution shall take effect immediately upon the adoption hereof.

PASSED AND ADOPTED this 19th day of November, 2024.



Mayor Jeffrey P. Freimark

ATTEST:

Dwight S. Danie, Village Clerk

APPROVED AS TO FORM AND LEGAL SUFFICIENCY:

Village Attorney
Weiss Serota Helfman Cole & Bierman P.L.

ASSIGNMENT OF AGREEMENT

This Assignment of Contract (the "Assignment") is effective as of **July 17, 2024** (the "Effective Date") by and between MIKYOUNG KIM DESIGN, a Massachusetts, corporation ("Assignor") and CHARLES BENSON AND ASSOCIATES, a Florida, corporation ("Assignee"), and BAL HARBOUR VILLAGE, Village, a municipal corporation, ("Village"). The above-referenced parties may be collectively referred to herein as the "Parties."

WHEREAS, Assignor and Village are parties in the Landscape, Architectural and Engineering Services agreement dated June 28, 2019 (the "Agreement") for the development of the Jetty and Adjacent Village Public Spaces Project (the "Project").

WHEREAS, as of the Effective Date, Assignor (and assignor's sub-consultants) have completed schematic design, design development, construction documents and partial permitting phase services in addition to partial work completed included in miscellaneous additional services no. 1-22 .

WHEREAS, as of the Effective Date, the Village has paid to Assignor all compensation and reimbursable expenses then due under the Agreement except for two hundred, ninety-six thousand, six hundred three dollars and .74 cents (**\$296,603.74**). Effective Date of this Agreement, all outstanding invoices for the assignor and assignor's sub-consultants, for service not yet performed, will be transmitted to the Assignee for processing of payments by the Village under the Village's payment schedule.

WHEREAS, pursuant to Section 11.5.1 of the Agreement, the Village retains the right to engage the services of additional third-party Consultants or assign responsibilities to a Village employee to perform the same of similar services provided by Assignor under the Agreement and to assign work to such parties at its sole discretion.

WHEREAS, under Section 11.5.2 of the Agreement, Assignor grants to the Village a nonexclusive and irrevocable license ("License") to use the Assignor's Instruments of Services for purposes of constructing, using, maintaining, altering and adding to the Project and to make future alterations or additions to the Project.

WHEREAS, the License shall permit the Assignor to authorize other Design Professionals to reproduce and to make changes, corrections and additions to the Instruments of Services for purposes of completing construction, using and maintaining the Project, as well as making future additions to the Project.

WHEREAS, the Village may assign the License to any party, such that the assignee may use the reproduction of the Instruments of Services to construct, use and maintain the Project, including making further additions or alterations.

WHEREAS, the Village uses the Instruments of Services directly, or by contracting with a third party, without retaining the authors of the Instruments of Service, the Village and the Assignee release the Assignor and its subconsultants from all claims and causes of action arising from uses.

WHEREAS, pursuant to Section 9.2 of the Agreement between the Parties, the Village consents to this Assignment.

WHEREAS, Assignee and Village will enter into a subsequent agreement for additional services performed by Assignee with the intent to retain Assignor and retain certain subconsultants currently engaged under the original Agreement or secure other subconsultants in furtherance of this Project.

NOW, THEREFORE, in consideration of the mutual covenants and agreements hereinafter set forth and for other good and valuable consideration, the receipt and sufficiency of which are hereby acknowledged, the Parties hereto agree as follows:

1. **ASSIGNMENT:** Assignor hereby assigns to Assignee of all of the interests, rights and title held by Assignor in and to the Agreement, and the Village hereby consents to such assignment and grants to Assignee a sublicense to use of the Assignor's design. Assignee hereby accepts such assignment and agrees to perform the Assignor's/Consultant's duties under the Agreement. Notwithstanding the foregoing, the provisions of Section 11.5 shall survive the assignment and continue in effect with respect to the Assignor, including without limitation, the terms of the license in

subsection 11.5.2 and the release and indemnification in subsection 11.5.4

2. **ASSUMPTION OF OBLIGATIONS:** Assignee acknowledges that Assignor will continue to perform services under the assignment limited to design work as enumerated in a subsequent agreement entered into between the Village and the Assignee and a subconsultant agreement between Assignee and Assignor. Further, the Assignor will relinquish any and all supervisory and oversight responsibilities of other subcontractors and subconsultants heretofore reporting to Assignor.

As of the date of this Assignment, Assignee hereby assumes all of Assignor's interests, rights, duties and obligations remaining in the Agreement.

As of the date of this Assignment, Assignee agrees to comply with all the terms, make all payments, from the date of the Assignment, and perform all conditions and covenants in the Agreement as if Assignee were an original party therein.

3. **ASSIGNOR'S REPRESENTATIONS:** Assignor warrants that the contract rights transferred in this Assignment are free of lien, encumbrance or adverse claim.
4. **INDEMNIFICATION:** Assignee agrees to indemnify and hold harmless the Village and its officers, employees, agents and contractors, from and against any and all third-party actions (whether at law or in equity), claims, liabilities, losses, judgments, costs and expenses, including, but not limited to, attorneys' fees and costs for personal or bodily injury, wrongful death, or loss of or damage to property, which may have arisen or be alleged to arise from the negligent acts, errors, omissions or the willful or intentional conduct of the Assignee, its officers, employees, agents, subcontractors or any other person or entity acting under Assignee's control or supervision, arising from the Assignor's performance of the Services pursuant to the original agreement between the Assignor and the Village prior to the effective date of the Assignment.

Assignee agrees to indemnify and hold harmless the Assignor and its officers, employees, agents and contractors, from and against any and all third party actions (whether at law or in equity), claims, liabilities, losses, judgments, costs and expenses, including, but not limited to, attorneys' fees and costs for personal or bodily injury, wrongful death, or loss of or damage to property, which may arise or be alleged to arise from the negligent acts, errors, omissions or the willful or intentional conduct of the Assignor, its officers, employees, agents, subcontractors or any other person or entity acting under Assignor's control or supervision upon commencement of this Assignment

Nothing in this Assignment shall be deemed or treated as a waiver by the Village of any immunity to which it is entitled by law, including but not limited to the Village's sovereign immunity as set forth in Section 768.28, Florida Statutes.

5. **BINDING EFFECT:** The covenants and conditions contained in the Assignment shall apply to and bind the Parties and their heirs, legal representatives, successors and permitted assigns.
6. **GOVERNING LAW:** This Assignment shall be governed by and construed in accordance with the laws of the State of Florida not including its conflict of laws rules that would refer to the laws of another jurisdiction.
7. **WAIVER:** The failure of either Party to enforce any provisions of this Assignment shall not be deemed a waiver or limitation of that Party's right to subsequently enforce and compel strict compliance with every provision of this Assignment.
8. **COUNTERPARTS:** This Assignment may be executed in any number of counterparts, each of which shall be deemed an original, and all of which together shall constitute one and the same document. In the event that any signature hereof is delivered by facsimile transmission or by e-mail as an attached, scanned document such signature shall create a valid and binding obligation of the Party or Other Party executing the same with the same force and effect as if such e-mailed or facsimile signature page were an original thereof.

IN WITNESS WHEREOF, the authorized representatives of the Parties have caused this Assignment to be executed effective as of the Effective Date.

ASSIGNOR: Mikyoung Kim Design



Name

Principal

Title

ASSIGNEE: Charles Benson and Associates

Name



Title

PRESIDENT.

OTHER PARTY CONSENT:

The undersigned, which is the Other Party to the Agreement, hereby consents to the foregoing Assignment and releases Assignor from its obligations and liabilities arising under the Agreement and accepts Assignee as a party to the Agreement in place of the Assignor.

BAL HARBOUR VILLAGE

Name

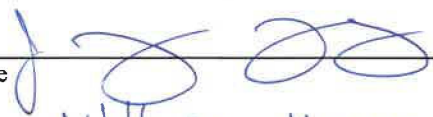

Title

Village Manager

ATTEST:

Name



Title

Village Clerk

APPROVED AS TO FORM AND LEGAL SUFFICIENCY:



Village Attorney

Weiss Serota Helfman Cole & Bierman P.L.

Exhibit "A"

**ADDENDUM TO THE SUBCONSULTANT CONTRACT FOR SERVICES
BETWEEN MIKYOUNG KIM DESIGN
(NOW ASSIGNED TO CHARLES H. BENSON & ASSOCIATES, ARCHITECTS, P.A.)
AND**

This Addendum to the Subconsultant Contract for Services between Mikyoung Kim Design, a Massachusetts for-profit corporation ("MYKD"), now assigned to, Charles H. Benson & Associates, Architects, P.A., a Florida for-profit corporation ("Benson"), and _____, a Florida for-profit corporation ("Subconsultant" or "_____"), is made and entered into this ___ day of ____, 2024.

WITNESSETH:

WHEREAS, on May 21, 2019, the Bal Harbour Village ("Village") entered into a Professional Services Agreement with MYKD for landscape architecture and engineering services for the Harbourfront Park, Jetty, and Cutwalk project ("Project");

WHEREAS, MYKD retained _____ as a subconsultant to provide _____ services on the Project;

WHEREAS, on July 17, 2024, the Village, MYKD, and Benson executed an Assignment of Agreement (Attachment "A" - Assignment), transferring MYKD's responsibilities under the then existing professional services agreement to Benson; and on August 9, 2024, the Village entered into a formal agreement with Benson (Attachment "B" - 2024 Master Owner-Architect Professional Services Agreement), assigning Benson the remaining duties to provide architectural design and construction administration services for the Project;

WHEREAS, this agreement and assignment grant Benson the authority to retain MYKD's subconsultants, engage additional third-party consultants as needed for the Project, and permit Benson and the subconsultants to mutually agree on modifications to the scope of services originally established in the subconsultant contracts with MYKD;

WHEREAS, via this Addendum to the Subconsultant Contract for Services, Benson intends to retain the services of the above-mentioned subconsultant, and both parties hereby agree to honor the original scope of services as well as the modifications specified herein;

IN CONSIDERATION OF THE MUTUAL COVENANTS AND CONDITIONS HEREIN EXPRESSED AND THE FAITHFUL PERFORMANCE OF ALL SUCH COVENANTS AND CONDITIONS, THE PARTIES AGREE AS FOLLOWS:

1. Each and every WHEREAS clause set forth above is a true and correct recital and representation and is incorporated herein as if set forth in full.
2. The original Subconsultant Contract for Services shall be modified as follows to include the following terms and revisions:

BASIC SERVICE FEES AND AMENDMENTS

The Village will honor the basic services fees, and any approved amendments enumerated in the assignment to Benson (Exhibit “A”). Any additional scope of work not included in the original scope of services and requiring an amendment shall be submitted to the Village and Benson for review and approval. Subconsultant shall not undertake such work until written approval from the Village and Benson is obtained.

STATUS REPORTING REQUIREMENT

The Subconsultant acknowledges that a status report (“Report”) must be provided to both the Village and Benson, detailing work completed to date and including PDFs of all finalized drawings. This Report must be submitted within seven (7) days of the execution of this Addendum. The Report should include any comments, recommendations, or unresolved concerns previously reported to MYKD. The Subconsultant shall specify whether such comments or concerns were documented in writing, the date they were initially raised with MYKD, and any responses received from MYKD.

CLARIFICATION OF PRIOR PAYMENTS (WAIVER OF CLAIM)

The subconsultant shall certify that all work previously performed under the agreement with MYKD has been completed and that the subconsultant has been fully compensated for these services. To the extent that the subconsultant has received full compensation for said services, the parties will execute a waiver of claim (Exhibit “B”). For any outstanding invoices previously unpaid by MYKD, the subconsultant shall provide written evidence that the unpaid work was completed and that an invoice was submitted for payment.

FUTURE INVOLICES AND PAYMENTS

The subconsultant agrees to submit future invoices to both Benson and the Village for review and approval. Upon approval, the Village, acting as fiscal agent, will issue payment directly to the subconsultant to ensure timely processing. While Benson will continue to oversee and manage the subconsultant’s work, Benson's financial obligation regarding compensation is nullified due to the Village’s direct payment responsibility.

In the event of any dispute or delay in payment from the Village, the subconsultant shall address the matter directly with the Village. Benson may assist in facilitating communication between the subconsultant and the Village to resolve any issues but will not be responsible for payments owed by the Village. For any additional work the subconsultant believes is beyond the scope of this Agreement, or work performed under protest at the Village's direction, as well as any offsets or deductions imposed by the Village related to the subconsultant’s work, the subconsultant shall work directly with the Village to resolve such matters.

CONFLICT BETWEEN AGREEMENTS OR FORMER DISCUSSIONS

In case of a conflict between this contract for services or any previous agreements or discussions between the parties and/or previous parties related to this Project, the 2024 Master Owner-Architect Professional Services Agreement (Attachment “B”) between Benson and the Village shall govern.

GOVERNING LOCATION

This Contract Addendum, along with all agreements arising from work related to this Project, shall be governed by the laws of the State of Florida. Any claims, disputes, or other proceedings, including mediation, shall be handled exclusively in Miami-Dade County, which shall have jurisdiction over all matters.

COMMUNICATION BETWEEN THE PARTIES

To ensure transparency and effective coordination, all communication between subconsultants and Benson or other parties outside of the Village, whether by phone, in-person meeting, or otherwise, shall be followed up with a written summary of the discussion via email within 72 hours. This email should include a copy to the Village's Capital Programs Director and any designee assigned by the Director. As the entity directing the contractor and overseeing project activities, the Village requires this notification to stay informed and support coordinated project execution.

3. This Addendum and the Subconsultant Contract for Services are solely between Benson and the subconsultant. The Village is included solely in the capacity of fiscal agent to facilitate the transition from MYKD to Benson and will now process direct payments to the subconsultants on behalf of Benson. This arrangement does not alter the contractual relationship, which remains exclusively between Benson and the subconsultant.
4. This Addendum to the Subconsultant Contract for Services shall be effective upon the signature of all parties.
5. Except as amended herein, all other provisions of the Subconsultant Contract for Services shall remain in full force and effect.

IN WITNESS WHEREOF, the parties hereto have accepted, made and executed this Addendum to the Subconsultant Contract for Services upon the terms and conditions above stated on the day and year first above written.

Subconsultant: _____

AOR: Charles H. Benson & Associates, Architects

Signature

Signature

Print Name

Charles H. Benson
Print Name

Title

Owner and Architect of Record
Title

Bal Harbour Village

Signature

Jorge M. Gonzalez, Village Manger
Print Name and Title

Exhibit A

BASIC SERVICES FEES AND APPROVED AMENDMENTS

Basic Fees allotted under Resolution 2019-1225 for	:	\$		
Amendment/Additional Service	:	\$		
Amendment/Additional Service	:	\$		
Amendment/Additional Service	:	\$		
Amendment/Additional Service	:	\$		
Total for	:	\$		
			Budgeted by Task:	Billed to Date
			Schematic Design:	Remaining to Bill
			Design Development:	
			Construction Documents:	
			Permitting:	
			Construction Administration:	
			Closeout:	
			Other:	
			Total:	

Exhibit B

WAIVER OF CLAIM FORM

Project Name: Harbourfront Park, Jetty and Cutwalk

Subconsultant: _____

Original Subconsultant Agreement Date: _____

Owner: Bal Harbour Village (“Village”)

Architect: Charles H. Benson & Associates Architects, P.A. (“Benson”)

I. Certification of Prior Payments

By signing this Waiver of Claim form, the undersigned subconsultant certifies that:

1. All work previously performed under the agreement with Mikyong Kim Design (“MYKD”) as of the date of this waiver has been completed in accordance with the terms of the agreement.
2. The subconsultant has received full and final compensation for all services rendered under the agreement with MYKD up to the date of this waiver.
3. Any outstanding amounts due for services rendered by the subconsultant remain unpaid solely due to MYKD’s failure to submit payment, and not for any lack of performance on the part of the subconsultant.

II. Waiver of Claim

To the extent that full payment has been received, the subconsultant hereby waives any and all claims against Benson, the Village as the Owner, and any other parties associated with this project, arising from or related to prior unpaid invoices or services performed under the agreement with MYKD.

III. Evidence of Outstanding Invoices

For any outstanding invoices that remain unpaid by MYKD, the subconsultant shall attach to this form:

- Written evidence, including copies of invoices and any relevant correspondence, demonstrating that the work associated with these invoices was completed in accordance with the agreement terms and submitted for payment.
- Confirmation that copies of the attached documentation have been provided to both the Village and Benson for record-keeping and verification purposes.

IV. Acknowledgment

The subconsultant acknowledges that, by signing this Waiver of Claim form, they have reviewed all prior payments received under the agreement with MYKD and affirm that they are waiving any claim or right to seek further compensation from Benson, the Village as the Owner, or any associated parties, except for any outstanding amounts that remain documented and unpaid as specified above.

Executed this ____ **day of** _____, **2024**

Subconsultant Signature: _____

Print Name: _____ **Title:** _____

BAL HARBOUR

- VILLAGE -

DISCUSSION ITEM

TO: Honorable Mayor and Village Council

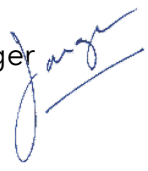
FROM: Jorge M. Gonzalez, Village Manager 

DATE: November 19, 2024

SUBJECT: **Discussion Regarding Upcoming Meeting Dates**

BACKGROUND

Section 22 of the Village Charter requires that the Village Council meet at least once each month, with the exception of August. For several years, the Village Council has opted to meet on the third Tuesday of each month at 6:30 p.m.

Should it be your pleasure to continue with this practice, in 2025, there are a few conflicts in the months of January, April, and December. The third Tuesday of January falls during the Winter recess for some of the local schools, the third Tuesday in April falls in the middle of Passover, and the third Tuesday of December falls during the Chanukah festivities. Therefore, I propose January 14, April 22, and December 9, as our meeting dates for these months.

Since September requires two meetings for the adoption of the fiscal year budget, the date of September 16 is highlighted as the monthly Village Council meeting and the second Budget Hearing date, with a First Budget Hearing date tentatively set for September 9 pending the Miami-Dade County and Miami Dade Public Schools setting their Budget Hearing schedule.

CONCLUSION

I therefore propose the following meeting schedule for 2025 for general discussion and consensus a 2025 Calendar of Potential Meeting Dates is attached as well.

- January 14, 2025
- February 18, 2025
- February 27 & 28, 2025 - Council Retreat
- March 18, 2025
- April 22, 2025
- May 20, 2025
- June 17, 2025
- July 15, 2025

- **(August Recess)**
- September 9, 2025 - First Budget Hearing
- September 16, 2025 - Second Budget Hearing & Village Council Meeting
- October 21, 2025
- November 19, 2025
- December 9, 2025

JANUARY

M	T	W	T	F	S	S
		1	2	5	4	5
6	7	8	9	10	11	12
13	14	15	16	17	18	19
20	21	22	23	24	25	26
27	28	29	30	31		

FEBRUARY

M	T	W	T	F	S	S
					1	2
3	4	5	6	7	8	9
10	15	12	13	14	15	16
17	18	19	20	21	22	23
24	27	26	27	28		

MARCH

M	T	W	T	F	S	S
					1	2
3	4	5	6	7	8	9
10	11	12	13	14	15	16
17	18	19	20	21	22	23
24	25	26	27	28	29	30
31						

APRIL

M	T	W	T	F	S	S
					5	6
7	8	9	10	11	12	13
14	15	16	17	18	19	20
21	22	23	24	25	26	27
28	30	30				

MAY

M	T	W	T	F	S	S
			1	2	3	4
5	6	7	8	9	10	11
12	13	14	15	16	17	18
19	20	21	22	23	24	25
26	27	28	29	30	31	

JUNE

M	T	W	T	F	S	S
						1
2	3	4	5	6	7	8
9	10	11	12	13	14	15
16	17	18	19	20	21	22
23	24	25	26	27	28	29
30						

JULY

M	T	W	T	F	S	S
		1	2	3	4	5
7	8	9	10	11	12	13
14	15	16	17	18	19	20
21	22	23	24	25	26	27
28	29	30	31			

AUGUST

M	T	W	T	F	S	S
					1	2
4	5	6	7	8	9	10
11	12	13	14	15	16	17
18	19	20	21	22	23	24
25	26	27	28	29	30	31

SEPTEMBER

M	T	W	T	F	S	S
1	2	3	4	5	6	7
8	9	10	11	12	13	14
15	16	17	18	19	20	21
22	23	24	25	26	27	28
29	30					

OCTOBER

M	T	W	T	F	S	S
		1	2	3	4	5
6	7	8	9	10	11	12
13	14	15	16	17	18	19
20	21	22	23	24	25	26
27	28	29	30	31		

NOVEMBER

M	T	W	T	F	S	S
					1	2
3	4	5	6	7	8	9
10	11	12	13	14	15	16
17	18	19	20	21	22	23
24	25	26	27	28	29	30

DECEMBER

M	T	W	T	F	S	S
1	2	3	4	5	6	7
8	9	10	11	12	13	14
15	16	17	18	19	20	21
22	23	24	25	26	27	28
29	30	31				

JANUARY

1st • New Years Day
20th • Dr. Martin Luther King's Birthday

FEBRUARY

17th • Presidents Day
27th & 28th • Village Council Retreat

MARCH

13rd & 14th • Purim

APRIL

12nd & 20th • Passover
29th • Good Friday

MAY

26th • Memorial Day

JUNE

1th - 3rd • Shavuot
19th • Juneteenth

JULY

4th • Independence Day

AUGUST

Council Recess

SEPTEMBER

1th • Labor Day
9th • First Budget Hearing
22nd-24th • Rosh Hashanah

OCTOBER



1sh & 2nd • Yom Kippur
6th - 13th • Sukkot
13th - 15th • Shmini Atzeret/Simchat





NOVEMBER

11th • Veterans Day
27th & 28th • Thanksgiving

DECEMBER

14th-22nd • Chanukah
25th • Christmas Day

 Proposed Village Council Meeting Dates
 Council Retreat Dates
 Tentative Second Budget Date
 Holidays - Village Hall Open Dates

 Weekend Dates
 Village Hall Observed Holidays
 N/A Village Election Date
 N/A Village Induction Date

BAL HARBOUR

- VILLAGE -

MEMORANDUM

TO: Honorable Mayor and Council

FROM: Dwight S. Danie, Village Clerk *OSD*

DATE: November 13, 2024

RE: Lobbyist Registration Report

Name of Lobbyist	Principal Represented	Date Registered
John Shubin	Mathew Whitman Lazenby	01/09/24
Ian DeMello	Mathew Whitman Lazenby	01/09/24
Darrell Payne	Saks Fifth Avenue LLC	01/16/24
Maria A. Gralia	Saks Fifth Avenue LLC	01/16/24
Seth P. Robert	Saks Fifth Avenue LLC	01/16/24
Previn R. Patel	Saks Fifth Avenue LLC	01/16/24
Mathew Lazenby	Bal Harbour Shops LLC	01/16/24
Benjamin Elias	Bal Harbour Shops LLC	01/16/24
Ivor Nicholas Massey	Bal Harbour Shops LLC	01/16/24
Caroline Travis	Bal Harbour Shops LLC	01/16/24
Nicholas Noto	LK Hotel, LLC	01/19/24
Carter McDowell	LK Hotel, LLC	01/19/24
Michael Marrero	1800 LLC	05/15/24
Melissa Tapanes Llahues	1800 LLC	05/15/24

BAL HARBOUR

- VILLAGE -

MEMORANDUM

TO: Honorable Mayor and Council

FROM: Susan L. Trevarthen *SLT*

DATE: November 12, 2024

RE: Monthly Report of Village Attorney for October Activities

Here is the monthly report on the Village Attorney's activities. While we attend to Village business and confer with Village officials continuously, this report highlights specific tasks and projects for the month. Please contact me or Robert Meyers if you have any questions about this report.

Retainer Services

Within the fixed fee retainer in October (104), we completed our work for the October Council meeting, and began to review, advise, and prepare documents for agenda items for the November Council meetings. We attended the weekly staff meetings and the monthly agenda review.

Specific additional matters included:

- We conferred with staff, reviewed correspondence and prepared response regarding building concerns at St. Regis.
- We drafted an easement re One Bal Harbour.
- We reviewed the declaration and termination of emergency related to storm, and advised re Code requirements.
- We worked with staff and counsel for Rivage on developing the voluntary contribution agreement and addressing other matters related to their permitting.
- We reviewed numerous correspondence and attended several conferences regarding Waterfront Park settlement and warranties.
- We examined case law concerning the factors to justify imposition of fines in code enforcement cases. We reviewed and analyzed case law on takings defense in code enforcement cases.
- We reviewed and analyzed various sections of the Village Charter and Attorney General Opinions regarding Charter amendment processes.
- We drafted correspondence regarding meeting procedures, and conferred re public records inquiry.

- We conferred with staff and reviewed multiple correspondence concerning prosecution agreements with State Attorney's Office and defense of municipal ordinance violations. We reviewed and approved driver's license civil citation agreement. We reviewed correspondence and conferred with Police Department concerning odor + one marijuana possession.
- We conferred with staff, reviewed and finalized Coaches' Code of Conduct.
- We reviewed and analyzed impact of proposed amendments to County Ethics Ordinance. We prepared materials for an ethics workshop with Village Manager's Office.

Additional Services

For the Dade County PBA Collective Bargaining matter, we reviewed and responded to various correspondence concerning bargaining strategy; prepared for and attended bargaining sessions; reviewed and responded to FMLA paperwork and reviewed and responded to correspondence concerning continued negotiations.

For NV2A Group Construction Litigation matter, we conferred with client, attended meetings and reviewed correspondence concerning settlement; followed up on status of close out agreement; conferred with client; and reviewed correspondence concerning warranties in connection with settlement.

For Bellini Condominium Association matter, we reviewed and drafted correspondence regarding settlement and discovery deadlines and prepared agreed order on discovery obligations; reviewed court order of voluntary dismissal with prejudice and finalized update to Council regarding settlement/dismissal.

For Bal Harbour Shops (Live Local Act) matter, we conferred with litigators regarding noise complaints and other litigation matters; reviewed, analyzed and prepared comments on filed versions of answers to complaints; reviewed counterclaims and drafted language for Letter to Council; conferred with client regarding settlement discussions and strategy; analyzed issues and conferred with litigators concerning public records exemptions and litigation privileges.

For Security/Landscape Assessment matter, we reviewed and drafted correspondence regarding review of expenses and retention of utility attorney, worked with staff and reviewed Kimley Horn gated community agreement, and conferred with staff concerning proposed FPL easement ordinance.