



**TOWN GRAY**  
**GRAY TOWN COUNCIL**  
**AGENDA • JANUARY 19, 2021**

---

Gray Town  
Council Regular  
Meeting

Online Via Microsoft Teams  
Link Posted to graymaine.org Day of Meeting

7:00 PM

---

**I.**

**OPENING STATEMENT:**

Due to the Governor's latest Executive Order, the Town Council meeting will NOT take place in person. The meeting will be held online with the link provided the day of the meeting.

**For the Public Hearing, Residents can click in to participate or call in using the number provided the day of - during the times detailed below. Public Comment are only allowed during the Public Hearing as detailed in the agenda.**

**II. ROLL CALL**

**III. PLEDGE OF ALLEGIANCE TO THE FLAG**

**IV. MINUTES FROM PREVIOUS MEETINGS**

1. To Review and Approve the Minutes from the Town Council Executive Session of December 14, 2020. **5 MINS (3 ES)**

Proposed motion:

**Ordered, The Gray Town Council Approves the Minutes from the Gray Town Council Executive Session of December 14, 2020.**

2. To Review and Approve the Minutes from the Town Council Executive Session of December 16, 2020.

Proposed motion:

**Ordered, the Gray Town Council Approves the Minutes from the Town Council Executive Session of December 16, 2020.**

3. To Review and Approve the Minutes from Town Council Executive Session of January 5, 2021.

Proposed motion:

**Ordered, the Gray Town Council Approves the Minutes from the Town Council Executive Session of January 5, 2021.**

4. To Review and Approve the Minutes from the Town Council Meeting of January 5, 2021. **5 MINS**

Proposed motion:

**Ordered, the Gray Town Council Approves the Town Council Meeting Minutes of January 5, 2021.**

5. To Review and Approve the Minutes from the Town Council Executive Session of January 8, 2021. **5 MINS**

Proposed motion:

**Ordered, the Gray Town Council Approves the Minutes from the Town Council Executive Session of January 8, 2021.**

**V. PUBLIC COMMENTS OF NON-AGENDA ITEMS (LIMIT 3 MINUTES PER PERSON). **10 MINS****

COMMENTS IN EXCESS OF 3 MINUTES ARE WELCOME AT THE END OF THE AGENDA PRIOR TO ADJOURNMENT. (FOR INFORMATION SHARING, NOT DISCUSSION.)

**VI. PRESENTATION(S)**

1. Stillwater Subdivision Contract Zone Agreement **15 MINS + 10 MINS Q&A**

**VII. PUBLIC HEARING(S)**

1. Second Reading - To Review and Act Upon Approving an Amendment to the Zoning Ordinance (Chapter 402) for the Town of Gray to Add Farmer's Market as a New Use and Associated Standards. **5 MINS (8:15pm)**

Proposed motion:

**Be it Ordained, the Gray Town Council Approves an Amendment to the Zoning Ordinance (Chapter 402) for the Town of Gray to Add Farmer's Market as a New Use and Associated Standards. 5 MINS**

2. Second Reading - to Review and Act Upon an Amendment to the Fireworks Ordinance for the Town of Gray to Allow Fireworks for the Lunar New Year. **5 MINS (8:25pm)**

Proposed motion:

**Be it Ordained, the Gray Town Council Approves an Amendment to the Fireworks Ordinance for the Town of Gray to Allow Fireworks for the Lunar New Year. 5 MINS**

**VIII. REPORT FROM THE COUNCIL CHAIR (Items VIII - XI 20 MINS TOTAL)**

**IX. REPORT FROM THE TOWN MANAGER**

1. GPCOG Stimulus Grants - Project Recommendations

**X. COMMITTEE REPORTS**

**XI. COUNCIL CORRESPONDENCE/ACTIVITIES**

**XII. ACTION ITEMS**

1. To Review and Approve any RFP Submissions for the Yarmouth Road Pocket Park. **10 MINS**

Proposed motion:

**Ordered, the Gray Town Council Approves the RFP Submission of \_\_\_\_\_ for the Yarmouth Road Pocket Park.**

**XIII. COUNCIL BUSINESS**

1. Senior Rebate Ordinance – Dan **15 MINS**
2. Tracking Worksheet & Workshop Schedule **10 MINS**

**XIV. ADJOURNMENT**

1. Motion to Adjourn – **9:05pm**

*\* The Town of Gray is an equal opportunity employer and complies with all applicable equal access to public accommodations law. If you are planning to attend a Town Council or Town committee or board meeting and need assistance with a physical disability, please contact the Town Manager's office at least 48 hours in advance of the meeting to have the Town assist you. 657-3339. TTY 657-3931.*

**TOWN GRAY**  
**GRAY TOWN COUNCIL**  
**MINUTES • December 14, 2020**

**Gray Town  
Council Special  
Workshop**



**4:30 PM**

Due to the Governor's latest Executive Order, the Town Council meeting will NOT take place in person. The meeting will be held online with the link provided the day of the meeting.

**ROLL CALL**

Attendee Name	Title	Status
Sandra Carder	Chair	Present
Bruce Foshay	Councilor	Present
Dan Maguire	Councilor	Present
Sharon Young	Councilor	Present
Anne Gass	Vice Chair	Present

**The Council Will Go into Executive Session, Pursuant to Title 1, Chapter 13, Subchapter 1, Section 405, Subsection 6-A: “Discussion or Consideration of the Employment, Appointment, Assignment, Duties, Promotion, Demotion, Compensation, Evaluation, Disciplining, Resignation or Dismissal of an Individual or Group of Public Officials...”, specifically to consider employment of a new Town Manager.**

<b>RESULT:</b>	<b>ADOPTED [UNANIMOUS]</b>
<b>MOVER:</b>	Bruce Foshay, Councilor
<b>SECONDER:</b>	Anne Gass, Councilor
<b>AYES:</b>	Gass, Young, Foshay, Maguire, Carder

Additional members in attendance at the Executive Session – Donald Gerrish, Consultant from Eaton-Peabody. The Council exited executive session around 5:20 pm. No action was taken on the matter.

**ADJOURNMENT - Motion to Adjourn at 5:30 pm.**

<b>RESULT:</b>	<b>ADOPTED [UNANIMOUS]</b>
<b>MOVER:</b>	Dan Maguire, Vice Chair
<b>SECONDER:</b>	Anne Gass, Councilor
<b>AYES:</b>	Gass, Young, Foshay, Maguire, Carder

**TOWN GRAY**  
**GRAY TOWN COUNCIL**  
**MINUTES • December 16, 2020**

**Gray Town  
Council Special  
Workshop**



**4:30 PM**

Due to the Governor's latest Executive Order, the Town Council meeting will NOT take place in person. The meeting will be held online with the link provided the day of the meeting.

**ROLL CALL**

Attendee Name	Title	Status
Sandra Carder	Chair	Present
Bruce Foshay	Councilor	Present
Dan Maguire	Councilor	Present
Sharon Young	Councilor	Present
Anne Gass	Vice Chair	Present

**The Council Will Go into Executive Session, Pursuant to Title 1, Chapter 13, Subchapter 1, Section 405, Subsection 6-A: “Discussion or Consideration of the Employment, Appointment, Assignment, Duties, Promotion, Demotion, Compensation, Evaluation, Disciplining, Resignation or Dismissal of an Individual or Group of Public Officials...”, specifically to consider employment of a new Town Manager.**

<b>RESULT:</b>	<b>ADOPTED [UNANIMOUS]</b>
<b>MOVER:</b>	Anne Gass, Councilor
<b>SECONDER:</b>	Bruce Foshay, Councilor
<b>AYES:</b>	Gass, Young, Foshay, Maguire, Carder

Additional members in attendance at the Executive Session – Donald Gerrish, Consultant from Eaton-Peabody. The Council exited executive session around 5:20 pm. No action was taken on the matter.

**ADJOURNMENT - Motion to Adjourn at 5:30 pm.**

<b>RESULT:</b>	<b>ADOPTED [UNANIMOUS]</b>
<b>MOVER:</b>	Sharon Young, Vice Chair
<b>SECONDER:</b>	Anne Gass, Councilor
<b>AYES:</b>	Gass, Young, Foshay, Maguire, Carder

**TOWN GRAY**  
**GRAY TOWN COUNCIL**  
**MINUTES • JANUARY 5, 2021**

**Gray Town  
Council Special  
Workshop**



**4:00 PM**

Due to the Governor's latest Executive Order, the Town Council meeting will NOT take place in person. The meeting will be held online with the link provided the day of the meeting.

**ROLL CALL**

Attendee Name	Title	Status
Sandra Carder	Chair	Present
Bruce Foshay	Councilor	Present
Dan Maguire	Councilor	Present
Sharon Young	Councilor	Excused
Anne Gass	Vice Chair	Present*
Deborah Cabana	Town Manager	Present

**The Council will go into Executive Session. Pursuant to Title 1, Chapter 13, Subchapter 1, Section 405, Subsection 6-C "Discussion or consideration of the condition, acquisition of the use of real or personal property or interests therein or disposition of publicly held property or economic development only if premature disclosures of the information would prejudice competitive or bargaining position of the body or agency" and Subsection 6-E "Consultation between a body or agency and its attorney concerning the legal rights and matters where the duties of the public body's or agency's counsel to the attorney's client pursuant to the code of professional responsibility clearly place the State, municipality or other public agency or person at a substantial disadvantage".**

<b>RESULT:</b>	<b>ADOPTED [UNANIMOUS]</b>
<b>MOVER:</b>	Dan Maguire, Councilor
<b>SECONDER:</b>	Bruce Foshay, Councilor
<b>AYES:</b>	Gass, Young, Foshay, Maguire, Carder

Additional members in attendance at the Executive Session – Kathy Tombarelli, Douglas Webster and Attorney Natalie Burns. The Council existed executive session around 5:17 pm. Chair Carder reported that Council directed staff to continue to work on a proposed contract zone for Stillwater Subdivision. No action was taken on the second matter.

**ADJOURNMENT - Motion to Adjourn at 7:18 pm.**

<b>RESULT:</b>	<b>ADOPTED [UNANIMOUS]</b>
<b>MOVER:</b>	Sharon Young, Vice Chair
<b>SECONDER:</b>	Dan Maguire, Councilor
<b>AYES:</b>	Gass, Young, Foshay, Maguire, Carder

**TOWN GRAY**  
**GRAY TOWN COUNCIL**  
**MINUTES • JANUARY 5, 2021**

**Gray Town  
Council Special  
Workshop**



**4:00 PM**

Due to the Governor's latest Executive Order, the Town Council meeting will NOT take place in person. The meeting will be held online with the link provided the day of the meeting.

**ROLL CALL**

Attendee Name	Title	Status
Sandra Carder	Chair	Present
Bruce Foshay	Councilor	Present
Dan Maguire	Councilor	Present
Sharon Young	Councilor	Excused
Anne Gass	Vice Chair	Present*
Deborah Cabana	Town Manager	Present

**The Council will go into Executive Session. Pursuant to Title 1, Chapter 13, Subchapter 1, Section 405, Subsection 6-C "Discussion or consideration of the condition, acquisition of the use of real or personal property or interests therein or disposition of publicly held property or economic development only if premature disclosures of the information would prejudice competitive or bargaining position of the body or agency" and Subsection 6-E "Consultation between a body or agency and its attorney concerning the legal rights and matters where the duties of the public body's or agency's counsel to the attorney's client pursuant to the code of professional responsibility clearly place the State, municipality or other public agency or person at a substantial disadvantage".**

<b>RESULT:</b>	<b>ADOPTED [UNANIMOUS]</b>
<b>MOVER:</b>	Dan Maguire, Councilor
<b>SECONDER:</b>	Bruce Foshay, Councilor
<b>AYES:</b>	Gass, Young, Foshay, Maguire, Carder

Additional members in attendance at the Executive Session – Kathy Tombarelli, Douglas Webster and Attorney Natalie Burns. The Council existed executive session around 5:17 pm. Chair Carder reported that Council directed staff to continue to work on a proposed contract zone for Stillwater Subdivision. No action was taken on the second matter.

**ADJOURNMENT - Motion to Adjourn at 7:18 pm.**

<b>RESULT:</b>	<b>ADOPTED [UNANIMOUS]</b>
<b>MOVER:</b>	Sharon Young, Vice Chair
<b>SECONDER:</b>	Dan Maguire, Councilor
<b>AYES:</b>	Gass, Young, Foshay, Maguire, Carder

**TOWN GRAY**  
**GRAY TOWN COUNCIL**  
**MINUTES • January 8, 2021**

**Gray Town  
Council Special  
Workshop**



**3:30 PM**

Due to the Governor's latest Executive Order, the Town Council meeting will NOT take place in person. The meeting will be held online with the link provided the day of the meeting.

**ROLL CALL**

Attendee Name	Title	Status
Sandra Carder	Chair	Present
Bruce Foshay	Councilor	Present
Dan Maguire	Councilor	Joined during Executive Session
Sharon Young	Councilor	Present
Anne Gass	Vice Chair	Present

**The Council Will Go into Executive Session, Pursuant to Title 1, Chapter 13, Subchapter 1, Section 405, Subsection 6-A: “Discussion or Consideration of the Employment, Appointment, Assignment, Duties, Promotion, Demotion, Compensation, Evaluation, Disciplining, Resignation or Dismissal of an Individual or Group of Public Officials...”, specifically to consider employment of a new Town Manager.**

<b>RESULT:</b>	<b>ADOPTED [UNANIMOUS]</b>
<b>MOVER:</b>	Anne Gass, Councilor
<b>SECONDER:</b>	Bruce Foshay, Councilor
<b>AYES:</b>	Gass, Young, Foshay, Carder

Additional members in attendance at the Executive Session – Donald Gerrish, Consultant from Eaton-Peabody. Council gave instructions to their Consultant and exited Executive Session around 7:00 pm.

**ADJOURNMENT - Motion to Adjourn at 7:07 pm.**

<b>RESULT:</b>	<b>ADOPTED [UNANIMOUS]</b>
<b>MOVER:</b>	Sharon Young, Vice Chair
<b>SECONDER:</b>	Anne Gass, Councilor
<b>AYES:</b>	Gass, Young, Foshay, Maguire, Carder

Wednesday 13<sup>th</sup> January 2021

Deb Cabana, Town Manager  
Town of Gray  
24 Main Street  
Gray, ME 04039

**RE: Contract Zone Agreement – Stillwater Pines, Gray, Maine**

Dear Deb,

On behalf of the property owner, Allen Hamilton and Ben Grover, we are writing to provide the terms for a Contract Zone Agreement to be presented to the Town Council. The items at the center of the agreement are an adjusted road section and an approximately 15-acre parcel of land to be used for municipal recreation field(s). The Contract Zone will extend over the entire parcel and include any future phases of the subdivision.

The benefits provided the Town will include the following:

- Approximately 14.8 acres located in the southeast corner of the subject property (see attached Sketch Plan) will be deeded to the Town. The property and included site improvements will be provided no later than 3-years after the approval of Phase 1 of the Stillwater Pines Subdivision. Owner will be permitted to remove material from the parcel prior to transferring it to the Town. A swing gate will be placed on the gravel access road just after the stream crossing.
- A 150-foot by 300-foot multi-use field will be built along with twenty parking. (Dean Bennet will be asked to weigh in on the dimensions and layout of the multi-use field). The field will be loamed and seeded until full grass coverage has occurred.
- A twenty-foot (20') wide gravel road for access to the ballfield (See Figure 1). The gravel road will start at the end of the Woodcock Drive extension. This will include any permitting required to access the property (stream crossing, stormwater, etc).
- A Right of Way to allow Woodcock Drive to loop back to Route 115 (Yarmouth Road) in the future.
- The existing trail system will be maintained (with minimal rerouting) and open to the public.
- An easement over Woodcock Drive will be given to the Town to provide winter and road maintenance.
- All current residence of Woodcock Drive will be given the opportunity to connect to public water at their expense.
- Once the grading of the site is complete an eight-foot (8') berm will be placed along the abutting property lines. The berm will be placed at a three to one (3:1) slope with two/three-yard boulders across the top. The boulders will be placed further than 6 feet apart.

- Electrical conduit and public water will be stubbed to the property line for the Town to tie onto at their convenience.

The adjustments to the required road section are as follows (See Figure 1):

For the existing portion of Woodcock Drive

- 18' Travel Lane
- 2' Paved Shoulder
- 5' Paved Sidewalk (flush with shoulder)

For the extension of Woodcock Drive

- 18' Travel Lane
- 2' Paved Shoulder
- 5' Paved Sidewalk (with curbing and a 4' esplanade).

Additional details:

- A grading easement will be provided over the 14.8 acres to allow the Owner to grade the site level with the abutting gravel pits.

Please contact me with any questions you may have about the project, or the attached information.

Regards,

*Charlie Burnham*

Atlantic Resource Consultants  
Charlie Burnham, PE  
Senior Engineer  
Mobile: 207.712.6990  
Email: [charlie@arc-maine.com](mailto:charlie@arc-maine.com)

**GENERAL NOTES:**

- OWNERS OF RECORD ARE BIRCHPOINT PROPERTIES, LLC AND A. H. GROVER, INC. BY DEED RECORDED IN THE CUMBERLAND COUNTY REGISTRY OF DEEDS IN BOOK 36,348 PAGE 165.
- AREA RETAINED FOR FUTURE PHASES CANNOT BE SOLD OR DEVELOPED WITHOUT A SITE LOCATION OF DEVELOPMENT PERMIT FROM THE MAINE DEPARTMENT OF ENVIRONMENTAL PROTECTION.
- ALL BEARINGS ARE REFERENCED TO MAGNETIC NORTH OF THE YEAR 1988 AS PER THE PLAN IN REFERENCE 5 AND CALCULATED FROM ANGLES OF AN ACTUAL ON THE GROUND SURVEY.
- THIS PROPERTY IS SHOWN AS LOT 32-112 ON TAX MAP 44 AND IS IN THE MEDIUM DENSITY (MD) AND THE RURAL RESIDENTIAL AND AGRICULTURAL (RRA) ZONING DISTRICTS.
- THIS PLAN REFERENCES A PLAN BY WAYNE WOOD AND CO. GRAY, MAINE 04039. PLAN TITLE: PLAN OF LAND ON WOODCOCK DRIVE FOR GRAY, MAINE ALLEN HAMILTON 170 SHAKER ROAD - GRAY, MAINE 04039. APRIL 2020, JOB NO. 22002, BY: WTW/KLW SCALE: 1" = 100' DRAWING NO. 1 OF 1
- ALL WETLANDS WILL BE PROTECTED AS FORESTED BUFFERS, INCLUDING SIGNS PROHIBITING ANY CLEARING OR DISTURBANCE BEYOND THE WETLAND LIMITS.
- EACH BUILDABLE LOT IS ALLOCATED 12,000 SQUARE FEET FOR DISTURBANCE.
- EXISTING CONTOURS ARE FROM LIDAR. CONTRACTOR IS REQUIRED TO CONFIRM THE TOPOGRAPHY IN THE VICINITY OF THE UDSP'S IS ALIGNS WITH THE LIDAR AND PROVIDE EVIDENCE TO THE TOWN ENGINEER THAT THE SYSTEM WILL WORK PROPERLY.

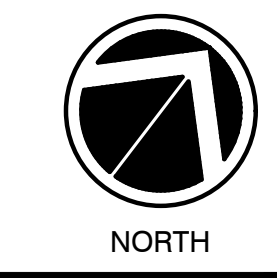

PROPOSED MULTI-USE FIELDS

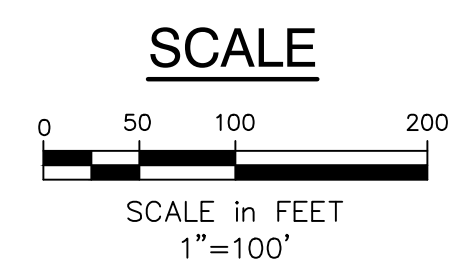

REV	DATE	DESCRIPTION

STILLWATER PINES SUBDIVISION  
WOODCOCK DRIVE, MAINE 04261  
CONCEPT  
BALL FIELD  
ALLEN HAMILTON & BEN GROVER  
170 SHAKER ROAD  
GRAY, MAINE 04039

Atlantic Resource Consultants  
541 US Route One  
Freeport, ME 04032  
Tel: 207.869.9050

DRAWN: MPV/CEB	DATE: APRIL 2020
DESIGNED: CEB/MPV	SCALE: 1"=100'
CHECKED: JAV/CEB	JOB NO. 20-012
FILE NAME:	
SHEET: SK-1	

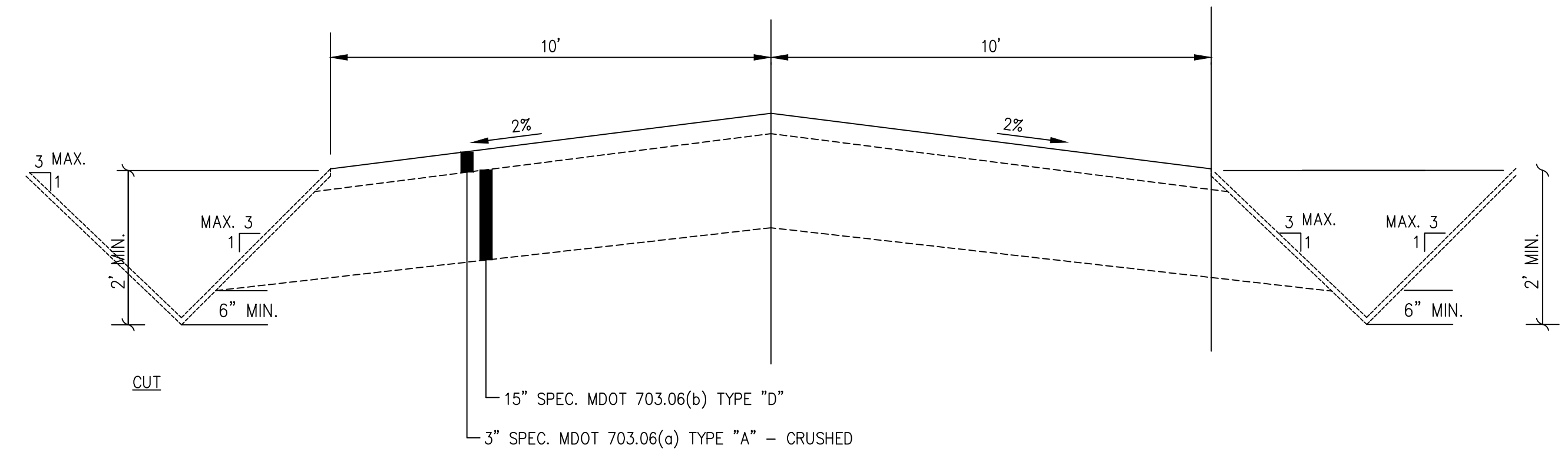

**(A) GRAVEL ROAD**  
N.T.S.

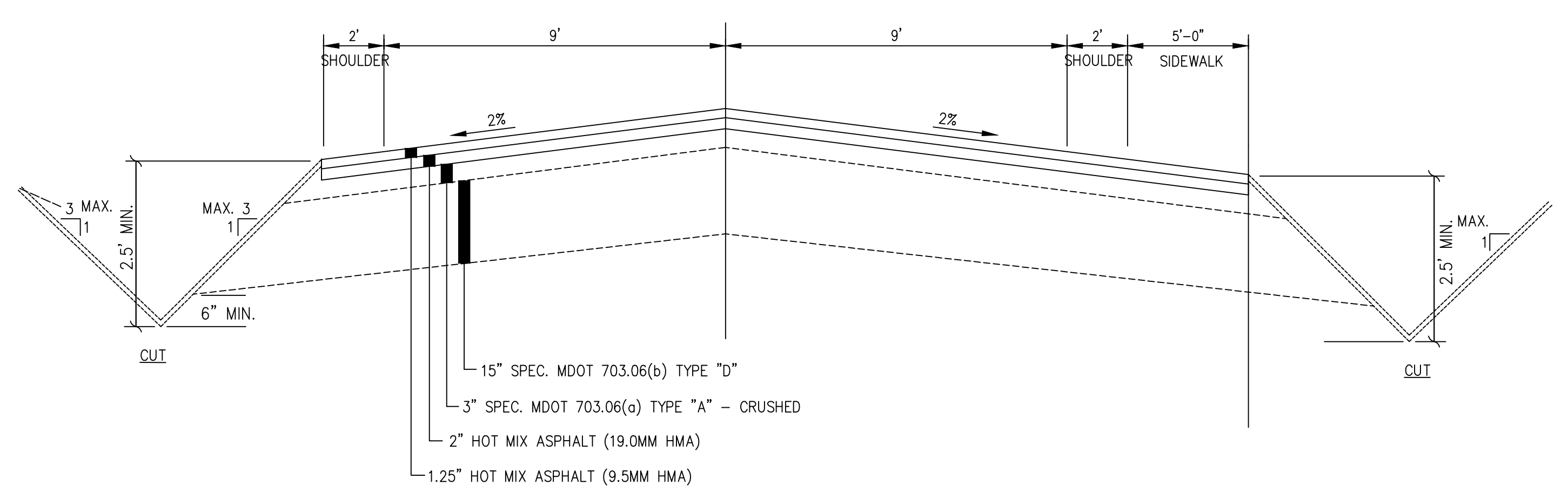

**(B) EXISTING WOODCOCK DRIVE IMPROVEMENT**  
N.T.S.

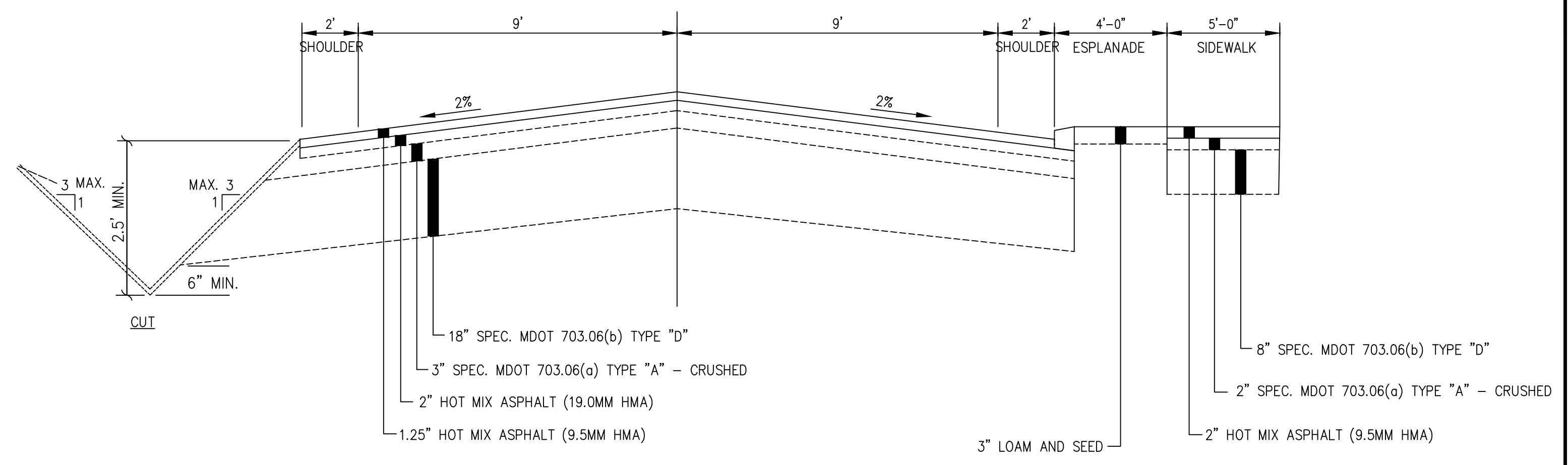

**(C) WOODCOCK DRIVE EXTENSION**  
N.T.S.

C. TABLE 401.13.16-2

ITEM	Sub-collector Streets	Village Public Street	Rural Public Street	Rural Public Easement Street	Minor Rural Street
A. Minimum width right of way <sup>1</sup>	60 ft	60 ft	50 ft	50 ft <sup>5</sup>	50 ft
B. Minimum grade	.5 percent <sup>2</sup>	.5 percent <sup>2</sup>	1 percent	1 percent	1 percent
C. Maximum grade	8 percent	8 percent	10 percent	10 percent <sup>3</sup>	10 percent <sup>3</sup>
D. Maximum grade within 75 ft of intersection	3 percent	3 percent	3 percent	3 percent	3 percent
E. Width of shoulders on each side	4 ft (paved)	4 ft (paved)	4 ft (paved)	2 ft (gravel)	2 ft (gravel)
F. Minimum travel way width	22 ft	20 ft	20 ft	18 ft	16 ft
G. Aggregate sub-base course gravel	15 inches	15 inches	15 inches	15 inches	15 inches
H. Aggregate upper base crushed gravel	3 inches	3 inches	3 inches	3 inches	3 inches
I. Bituminous paving	3-1/4 inches	3-1/4 inches	3-1/4 inches	3-1/4 inches	
J. Sidewalks (one side min.):					
Minimum width	5 ft	5 ft			
Aggregate sub-base course gravel	8 inches	8 inches			
Aggregate upper base crushed gravel	2 inches	2 inches			
Bituminous paving	2 inches	2 inches			
K. Minimum curb radii:					
90 degree intersections	40 ft	25 ft	25 ft	15 ft	15 ft
Less than 90 degrees	40 ft	30 ft	30 ft	20 ft	20 ft
L. Minimum dwelling units	51	4	26	11	2
M. Maximum dwelling units	100 <sup>4</sup>	50	50	25	10

REV	DATE	DESCRIPTION
REVISIONS		

STILLWATER PINES SUBDIVISION  
WOODCOCK DRIVE, MAINE 04261  
ROAD SECTION  
SCHEMATIC  
ALLEN HAMILTON & BEN GROVER  
170 SHAKER ROAD  
GRAY, MAINE 04039

**Atlantic Resource Consultants**  
541 US Route One  
Freeport, ME 04032  
Tel: 207.869.9050

DRAWN: MPV	DATE: JANUARY 2021
DESIGNED: CEB/MPV	SCALE: N.T.S.
CHECKED: JAV/CEB	JOB NO. 20-012
FILE NAME:	
SHEET: SK-1	

**01/05/2020 Town Council Meeting  
Proposed Farmers' Market Ordinance Amendments**

**402.2.2 Definitions (Add the following definitions)**

Farm and Food Products: Any agricultural, horticultural, forest or other product of the soil or water, including, but not limited to, fruits, vegetables, eggs, dairy products, meat and meat products, poultry and poultry products, fish and fish products, grain and grain products, honey, nuts, maple products, apple cider, fruit juice, malt liquor, wine, ornamental or vegetable plants, nursery products, fiber or fiber products, firewood and Christmas trees.

Farmer: A person who produces farm products.

Farmers' Market: A seasonal public market at which two (2) or more local farmers have raised and/or prepared farm and food products for direct sale to consumers.

**Table 402.5.3 (Add Farmers' Market to USE table)**

TABLE 402.5.3 TABLE OF PERMITTED USES AND CONDITIONAL USES															
		RRA	LD	MD	BD-1	BD-2	C	VC	VCP	BT-1	BT-2	WH-1	WH-2	LMOD	CSESOD
22	<u>Farm Stand++</u>	P	P	P	P	P	P	P	P	P	P		P		
<b>23</b>	<b><u>Farmers' Market ++</u></b>	<u>P</u>	<u>P</u>	<u>P</u>	<u>P</u>	<u>P</u>	<u>P</u>	<u>P</u>	<u>P</u>	<u>P</u>	<u>P</u>		<u>P</u>		
<b>24</b>	<b>(change subsequent numbering in rest of table)</b>														

++ Subject to performance standards in Article 7

**402.7.21 FARMERS' MARKET (New Section)**

A. The purpose of this ordinance is to regulate the temporary use of land for the establishment of farmers' markets as defined by 7 M.R.S. §415, where the primary purpose of the market is to make local farm and food products available to the public.

B. Administration and Enforcement: This ordinance shall be administered by the Community Development Department and enforced by the Code Enforcement Officer.

C. Farmers' Market on Town Property: The Town Council may authorize the Town Manager to enter into a lease or license agreement for the use of Town property for the purpose of operating a Farmers' Market. No license for the sale at a Farmers' Market of any items shall be issued by the Town Clerk until the applicant has filed with the Town Clerk a certificate evidencing liability coverage at the minimum amount recommended by Maine Municipal Association at the time of the event and naming the Town as an additional insured. The licensee shall maintain such insurance at all times while engaged in sales at a farmers' market, and the licensee shall provide the Town Clerk with not less than ten (10) days' advance written notice of the cancellation, expiration or non-renewal of said insurance.

D. Farmers' Market on Private Property: Farmers' Markets may take place on private property, where allowed as a permitted or conditional use under Chapter 402 with written consent of the property owner.

E. Prohibitions

1. A person may not use the terms "Farm and Food Products", "Farmer", or "Farmers' Market" to describe a market or other sales that does not meet the terms of the definitions set forth in 402.2.2.
2. A person may not sell farm and food products at a market labeled "farmers' market" unless at least 50% of the farm products offered by that person were grown, processed, or prepared by that person or under that person's direction.
3. A product not grown, processed, or prepared by the farmer or under that farmer's direction must have been grown, processed, or prepared by and purchased directly from another farmer and the name and location of the farm must be identified on the product or on a sign in close proximity to the displayed product.
4. Invasive terrestrial plants, weapons, fireworks, tobacco or tobacco products, and marijuana, marijuana products or tobacco/marijuana paraphernalia are prohibited. Hemp-based Cannabidiol (CBD) products are allowed if locally sourced and prepared by the farmer.
5. Live animals offered for sale are prohibited.

F. Additional Conditions for Farmers' Markets

1. Sufficient off-street parking, not within a public way, must be provided for both the Farmers' Market vendors and their patrons. One space per 400 sf of stalls/tables is required.
2. The items to be sold at the Farmers' Market are intended to be local farm products. Craft items made by the farmers/vendors are allowed but limited to 25% of the products offered for sale by the market.
3. Mobile, temporary, and non-permanent stationary food vending units, and mobile ice cream vendors, are prohibited from participating in duly approved Farmers' Market locations without a Mobile Vendor or Food Truck license issued by the Town of Gray.
4. The term of a license shall not extend beyond a 12-month period. Annual renewals may be permitted in the same manner as an initial license agreement.
5. Farmers' Markets that exceed 20 farmers and/or tables/stalls require Staff Review Committee or Planning Board approval as applicable.
6. Farmers' Markets are limited to two days a week between the hours of 8:00 am and 6:00 pm.
7. All Farmers' Markets must adhere to State standards including Title 7, Part 2, Chapter 101, Subchapter 1-A, subsection 415 which specifies produce and products eligible to be sold.

8. All Farmers' Markets must adhere to applicable Town standards, specifically including the Local Food Ordinance and Zoning Ordinance provisions.
9. This section does not prohibit a market from imposing more stringent requirements on its sellers than those imposed by the Town.
10. This section does not prohibit individual Farmers' Markets to charge their own table/stall fees in addition to the fees the Town charges pursuant to the Town Council approved Fee Schedule.
11. Signage for Farmers' Markets must comply to Chapter 406 Town of Gray Sign Ordinance.

#### G. Permitting Procedure

1. Application Submittal: Applicants shall submit an application packet in a manner specified by the Town and shall include such fees as established by the Town Council.
2. Staff Review: The Community Development Department shall circulate the application to Gray Fire Rescue and Public Works Department within 3 business days of receipt of a complete application. The Community Development Department shall submit any written comments within 5 business days to the Town Manager.
3. Farmers' Market with  $\leq$  20 farmers and/or tables/stalls: Subsequent to the receipt by the Town Manager of the staff recommendation and prior to the issuance of a license agreement, the Town Council shall hold a Public Hearing at the first available Town Council Meeting. In addition to general notice, notice of the public hearing shall be mailed to immediate abutters no later than 7 days prior to the hearing.
4. Farmers' Markets with  $>$  20 farmers and/or tables/stalls: Subsequent to receipt of staff recommendations and all applicable materials for Site Plan Review are received by the Town Planner, the application shall be placed on the next available Staff Review Committee or Planning Board agenda as applicable for Site Plan Review and a Public Hearing. In addition to general notice, notice of the public hearing shall be mailed to abutters within 250' of the parcel on which the Farmers' Market is to be located no later than 7 days prior to the hearing.

Notes to Council – changes made to the ordinance since 12/1/2020 Meeting:

1. Section E. Prohibitions – separated E.2 into E.2 & E.3 (run-on). Added “or prepared by” to language based on Rachel Lyn comments about baked goods.
2. Deleted F.1 as pointed out by Sharon as repetitive and re-numbered section.
3. Moved the old F.4 up to section E as E.4 as it fit better in prohibitions. Clarified CBD language.
4. Added E.5 to prohibitions.
5. Re-worded F.2 to allow market to self-regulate the 25% craft threshold by market in aggregate and not individual vendors.
6. Combined sections G & H into one section.

**Town of Gray**  
**Chapter 209**  
**Fireworks Ordinance**  
**Adopted June 14, 2018**  
**Amended January 5, 2021**

Section 1. Purpose

This Ordinance regulates the use of professional fireworks and consumer fireworks to ensure the safety of the residents and property owners of the Town of Gray and the general public.

Section 2. Title and Authority

This Ordinance shall be known as the "Town of Gray Fireworks Ordinance." It is adopted pursuant to the enabling provisions of the Maine Constitution, the provisions of 30-A M.R.S.A. Section 3001, and the provisions of 8 M.R.S.A. Section 223-A, and the Town Charter for the Town of Gray.

Section 3. Definitions

The following words, terms and phrases, when used in this Chapter, shall have the meanings ascribed to them in this section, except where the context clearly indicates a different meaning:

- A. Consumer Fireworks: "Consumer Fireworks" has the same meaning as in 27 Code of Federal Regulations, Section 555.11 or subsequent provision, but includes only products that are tested and certified by a 3rd-party laboratory as conforming with United States Consumer Product Safety Commission standards, in accordance with 15 United States Code, Chapter 47. Consumer Fireworks does not include the following products:
1. Missile-type rockets, as defined by the Office of the State Fire Marshal by rule;
  2. Helicopters and aerial spinners, as defined by the Office of the State Fire Marshal by rule; and
  3. Sky rockets and bottle rockets. For purposes of this definition, "sky rockets and bottle rockets" means cylindrical tubes containing not more than 20 grams of chemical composition, as defined by the Office of the State Fire Marshal by rule, with a wooden stick attached for guidance and stability that rise into the air upon ignition and that may produce a burst of color and/or sound at or near the height of flight.
- B. The term "Fireworks" does not include consumer fireworks or toy pistols, toy canes, toy guns, or other devices in which paper caps or plastic caps containing 25/100 grains or less of explosive compound are used if they are constructed so that the hand cannot come in contact with the cap when in place for the explosion,

toy pistol, paper caps, or plastic caps that contain less than 20/100 grains of explosive mixture, or sparklers that do not contain magnesium chlorates or perchlorates.

- C. Fireworks Display: An entertainment feature where the public or a private group is admitted or permitted to view the display of fireworks or consumer fireworks or special effects.
- D. Fireworks: The same meaning as that term defined under State Law, 8 M.R.S.A. Section 221-A(4), as may be amended from time to time.
- E. Person: Any individual, partnership, limited liability company, corporation, governmental entity, association, or public or private organization of any character.
- F. Town: The Town of Gray, Maine.

#### Section 4. Use of Consumer Fireworks Restricted

A person shall not use, display, fire, or cause to be exploded (collectively "Setting Off") consumer fireworks within the Town of Gray or in or from any watercraft within waters of the Town except upon the following conditions:

- A. No fireworks shall be set off on any day with a Fire Danger Class of 3 (high), 4 (very high), or 5 (extreme), as determined by the Maine Forest Service. Any person(s) setting off fireworks shall be responsible for verifying the Fire Danger Class on any day that consumer fireworks are set off.
- B. No person shall set off, use, display, throw, drop or cause to set off any consumer fireworks or fireworks within any public way or within 50 feet of a public way.
- C. Consumer Fireworks may only be set off during the following days/times:
  - Summer:
    - 1. July 3<sup>rd</sup>: 12:00 P.M. until 10:00 P.M.
    - 2. July 4<sup>th</sup>: 12:00 P.M. until 11:00 P.M.
    - 3. From 6:00 P.M. to 10:00 P.M. for the following days:
      - a. Saturday preceding July 4<sup>th</sup>
      - b. Saturday following July 4<sup>th</sup>
      - c. Saturday preceding Labor Day weekend
      - d. Labor Day weekend Saturday
    - New Year's: 4. 9:00 AM on December 31st until 12:30 A.M. on January 1st
  - 5. January 1st from 12:00 P.M. until 10:00 P.M. Other:
    - 6. Lunar New Year (Chinese New Year), as denoted on any officially published calendar: 12:00 midnight until 1:00 A.M.

- D. No person shall set off, use, display, throw, drop or cause to set off any consumer fireworks or fireworks within 75 feet of any building or structure.

#### Section 5. Professional Fireworks Standards

Pursuant to 8 M.R.S.A. Section 227-B, this section establishes standards for the use, display, or setting off fireworks, as defined in 8 M.R.S.A. Section 221-A(4), that require a permit from the Maine Commissioner of Public Safety or designee.

- A. No fireworks shall be set off on any day with a Fire Danger Class of 3 (high), 4 (very high), or 5 (extreme), as designated by the Maine Forest Service. The person or entity setting off fireworks shall be responsible for verifying the Fire Danger Class on any day that fireworks are set off.
- B. Any person that is required to obtain a fireworks display permit from the Maine Commissioner of Public Safety under 8 M.R.S.A, Sections 221-237 and 227-A shall also be required to obtain a permit from the Gray Department of Public Safety. The applicant shall submit the following information to the Gray Fire Chief at least 14 days in advance of the scheduled event:
  - 1. Location of the event including a plan showing the area where the display is to occur.
  - 2. Responsible party including contact information both prior to and during the event.
  - 3. Commencement time and ending time.
  - 4. Description and listing, including approximate quantity, of the fireworks to be displayed.
  - 5. Detailed description of safety and security measures to be taken.
- C. The professional fireworks display shall not occur unless the Gray Department of Public Safety has duly issued the Town permit.
- D. No permit for professional fireworks display shall be issued between May 10th and June 20th on any property or location within 2000 feet of a body of water in excess of 10 acres.
- E. The party or entity setting off the fireworks display shall be responsible for ensuring that all fireworks stored on the site before the display are sufficiently secured and protected including having appropriately trained personnel staying on site.

#### Section 6. Administration and Enforcement

- A. Copy to State Fire Marshal: Per Title 8 M.R.S.A. Section 223, the Town Clerk shall file a copy of this Ordinance, any amendments thereto, with the State Fire Marshal within 30 days of adoption or amendment.

- B. Any State or County Law Enforcement official may enforce the provisions of this Ordinance specifically including duly-authorized representatives from Cumberland County Sherriff, Maine State Police, Maine Department of Inland Fisheries & Wildlife, and Maine Department of Public Safety (State Fire Marshal's Office).

#### Section 7. Seizure and Disposal

The Town or any person authorized to enforce this Ordinance may seize fireworks that it has probable cause to believe are to be used in violation of this Ordinance. All fireworks lawfully seized under this Ordinance shall be forfeited to the State per 8 M.R.S.A. Section 237(2).

#### Section 8. Violation(s) and Penalties

- A. Use of fireworks in violation of this Ordinance shall be subject to a fine of not less than \$100 nor more than \$250 plus attorney costs for the first offence, or a fine not less than \$250 nor more than \$750 plus attorney costs for each subsequent offence within any previous two (2) year period.
- B. Injunction: In addition to any other remedies available at law or equity, the Town of Gray, acting through its Town Manager, may apply to any court of competent jurisdiction to enjoin any planned, anticipated, or threatened violation of this Ordinance.

#### Section 9. Appeals

Appeals with respect to this Ordinance including fines shall be taken within 30 days to the Gray Town Council who shall be the final authority.

#### Section 10. Savings Clause

In the event that any provision of this Ordinance is found by a court of competent jurisdiction to be invalid, this finding shall not affect the remainder of this Ordinance.

#### Section 11. Effective Date

This Ordinance shall be effective on June 14, 2018.

# 2071 permaculture

connecting people, places and patterns in maine

## Contract Proposal Yarmouth Road Pocket Park

### Gray Urban Food Forest

5 Yarmouth Road, Gray, Maine

Elevation +308'  
Magnetic Declination 15° West  
43° 53'7" North 70° 19'47" West

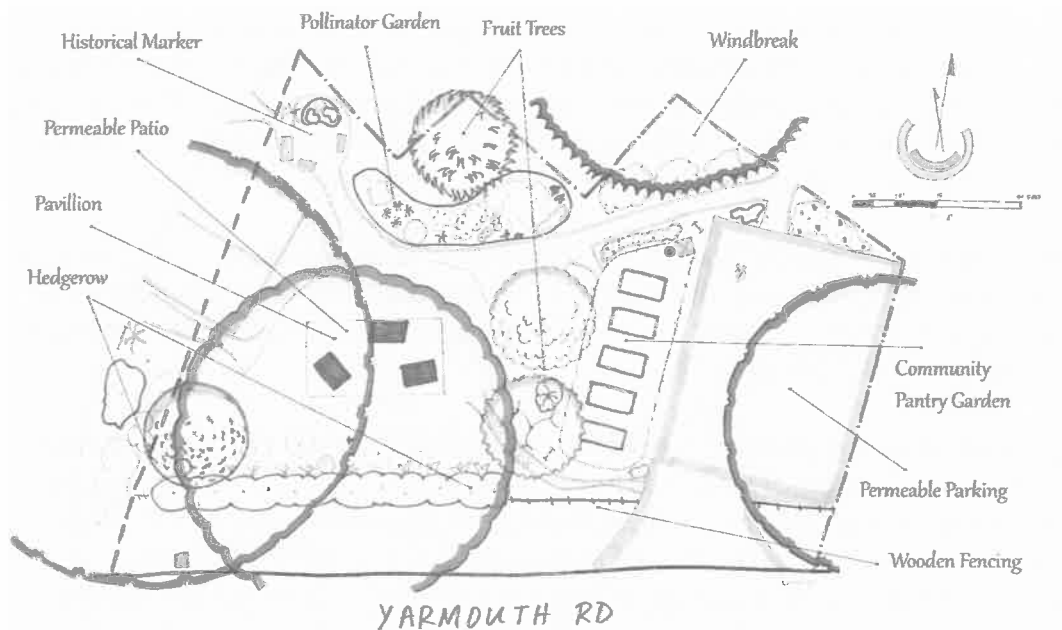

*Edible Landscape / Stormwater Management / Community Garden / Gathering Place*

Submitted by:  
Rachel Lyn Rumson  
8 George Perley Rd  
Gray, Maine USA  
+1 207 332-7224  
[www.207permaculture.com](http://www.207permaculture.com)

“Soil, not oil, holds the future for humanity.” -Vandana Shiva

January 9, 2020

Dear Gray Town Councilors,

It has come to my attention that you are seeking proposals for .2 acres of green space at Gray Corner. As you know I am intimately familiar with this project. I would like the opportunity to be considered for the design work going forward, however I welcome collaboration with other permaculture designers, should you decide to go in another direction.

Permaculture design weaves together the imaginations and input of many people in a community into a shared plan for ecological, and social resilience. (It is a lot like a comprehensive plan process actually.) The design process must be iterative because there are many voices to consider, among them, yourselves, abutters, municipal staff, residents, local teachers, volunteers, and youth. We permaculture designers often say that site plans are “implemented as time, money, and energy allow”. The energy comes from the spirit of community, generated in the hearts and minds of many people along the way, and harvested by data collection and conversation.

The sponsor-designer relationship is the foundation relationship for any permaculture design, the soil, if you will, and the quality of which will have both tangible, and intangible impact on the outcome. It is for that reason that I especially appreciate your call for collaboration in the RFP.

A sponsor has unique authority in a system to invite the participation of multiple stakeholders, and groups of stakeholders. Invitations to participate in a survey, a workshop, an interview, a permaculture class, and site walks, are all missing sponsorship currently, however this RFP requires collaboration of multiple stakeholders in the planning process. As a designer, it is my preference to negotiate agreements about an entire process including scope of work, goal of project, timeline, budget, including both in-kind donations and paid service. That has not been our collaborative process so far. This RFP segregates a piece of work out from the whole process. Therefore, if you decide to accept my design proposal, I humbly request your leadership as sponsor, to endorse a process to maximize engagement in the planning conversation by approving of the engagement strategy and inviting participation in it.

Please let me know if this requires adjustment to match your understanding and expectations.

**Project Goals/Objectives:**

The collaborative design process may illuminate even more considerations, however it

is my understanding that you are interested specifically in the following:

- Accessible Seating area(s)
- Designated location for Historical Monumentation
- On-site stormwater management
- Edible hedging and raised planter beds
- Native planting schedule
- Utilize low maintenance materials
- Design & included design elements must meet grant budget
- Incorporate urban permaculture methods
- Standard dimensions for parking features if included

**Suggested Project Scope February 01, 2021 - June 15, 2021**

<i>Work Item</i>	<i>Estimated Hours</i>
<b>Part 1: Site Work</b> <ul style="list-style-type: none"> <li>● Review of existing conceptual plans</li> <li>● Basemap creation and measurement</li> <li>● Site walk</li> </ul>	3 h
<b>Part 2: Assessment and Analysis</b> <ul style="list-style-type: none"> <li>● Document site summary and review for all collaborators</li> <li>● Joint analysis of site assets and challenges, inputs and outputs with all collaborators</li> <li>● Soil Test Analysis and recommendations for biological amendment</li> <li>● Public feedback integration</li> </ul>	9 h
<b>Part 3: Conceptual Design and Permitting</b> <ul style="list-style-type: none"> <li>● Site plan with narrative and 2 detail perspectives, and plant list, and budget and timeline</li> </ul>	12h
<b>Part 4: Permitting</b> <ul style="list-style-type: none"> <li>● Two public presentations</li> </ul>	2 h
<b>Estimated Total Work under this scope of work</b>	<b>Approx 27 h</b>
Rate:	\$1800.00
\$65.00/hour	

The Client understands that the time noted above is an estimated time budget only and is based on the scope of work requested by the Client to date. Changes in the scope of work, terms, or conditions, may affect the time devoted by the Consultant, and will be agreed upon by both parties in writing.

**About Rachel Lyn Rumson**

Rachel Lyn has been practicing the ethics of permaculture in Maine for nine years. She completed her Permaculture Design Certificate (PDC) course, and an Advanced PDC with The Resilience Hub 2011 and 2013 respectively. Her design portfolio includes three different community-scale designs for school systems with curriculum layers and six private residences. She is often in the garden with dirty hands and a happy heart, learning how to have a more caring relationship with the land through plant and soil work and her community through food systems and ecological restoration work.

Rachel Lyn served as Program Director of Social Permaculture at the Resilience Hub for three years where she developed a permaculture design consulting team, a community tool library, a community land trust, and created the “Cooperative Design Lab” using her background in leadership and organizational development. She co-hosted several regional permaculture events including a Permaculture Educators Gathering in 2011, the 2012 New England Transition Gathering and the 2014 Northeast Permaculture Convergence. She is a member of the Permaculture Women’s Guild and teaches permaculture with them internationally, as well as locally with the Center for an Ecology Based Economy, Cumberland County Soil and Water Conservation District and Community and Adult Education in Cumberland and Gray.

**Terms**

Confidentiality and Privacy	This proposal and any conversations leading up to it are considered private and confidential by Rachel Lyn Rumson. She adheres to a strict privacy policy regarding work performed for clients and data belonging to clients. In the course of our work, we may come in contact with proprietary or confidential information. This information will not be communicated, shared, or exposed to security risks at any time, to the best ability of our staff.
Validity	This quotation is valid for 90 days and for work completed within 4 months. Additional work beyond the scope of this quotation can be added to the project at any time by mutual written agreement.
Standard Rates	The billable rate for this type of work is \$65/hr.
Standard Payment Terms (for finite projects)	<ul style="list-style-type: none"><li>● <i>To be paid in installments.</i></li><li>● <i>1/2 to begin work</i></li><li>● <i>Billable hours monthly until completion.</i></li></ul>
Travel Fees	Within a 3-hour drive of Portland, Maine, USA standard mileage rates (per the IRS web site) will be charged for inbound and outbound travel for each team member. Every effort will be made to carpool..  Travel beyond a three-hour drive time from Portland will be subject to the standard hourly rate for inbound travel time from PWM, and any costs associated with travel to/from your designated work site (air/train/car rental, lodging, expenses).

	Within a 30 minute drive of my design studio, no travel charges are incurred.
Incidental Expenses	Expenses such as printing fees, incurred as a result of performing work under this quote will be included on your invoice for reimbursement at cost.
Deviation from Estimates	Time estimates are based on my experience with various permaculture projects over the years. If unforeseen issues arise requiring additional hours, they will be raised for discussion and a course of action will be agreed before additional work is performed.
Amendment to Quotation	If any of the contents of this document differ from your understanding of the proposed work or terms, please notify us at once so that we can establish a proper mutual understanding prior to commencement of work. The terms and conditions stated herein override any other terms unless otherwise agreed in writing.
Scheduling Constitutes Agreement	Written (including fax or email authorization) or verbal scheduling of work described in this document constitutes acceptance of the terms and conditions of engagement and "authorization to proceed."

If you agree that this letter correctly states your understanding of the nature and scope of this engagement, please sign two copies of this letter and return one to me.

Respectfully Submitted,

*RL Rumson*

Rachel Lyn Rumson

I agree that this letter accurately describes the agreement between Rachel Lyn Rumson and Kathy Tombrelli, Town Planner, Town of Gray.

Client Signature \_\_\_\_\_

Title: \_\_\_\_\_ Date: \_\_\_\_\_



Draft Conceptual Plan Submitted with Proposal to the Town of Gray on 1/11/2021 by Rachel Lyn Rumson

# Gray Urban Food Forest: A Micro Park

Elevation +308'  
Magnetic Declination 15° West  
43° 53' 7" North 70° 19' 47" West

5 Yarmouth Road, Gray, Maine



Edible Landscape / Stormwater Management / Community Garden / Gathering Place



**CHAPTER 305**  
**SENIOR PROPERTY TAX ASSISTANCE**  
**TOWN OF GRAY MAINE**

*Adopted January 21, 2020, Effective February 20, 2020*

~~This Ordinance shall be known and may be cited as the Active Duty Military Excise Tax Exemption Ordinance of the Town of Gray, Maine.~~

**SECTION 305.1 –PURPOSE**

The purpose of this article is to establish a program to provide property tax assistance to persons ~~seventy (70) years of age and over~~ who reside in the Town of Gray. Under this program, the Town of Gray will provide refund payments to those individuals who maintain a homestead in the Town of Gray and meet the criteria established by this article. The money will be repaid to the Town upon the sale or transfer of ownership of the property.

**SECTION 305.2 –DEFINITIONS**

As used in this article, the following terms shall have the meanings indicated:

~~BENEFIT~~ **REFUND BASE:** Property taxes paid by a qualifying applicant during the tax year on the qualifying applicant's homestead or rent constituting property taxes paid by the resident individual during the tax year on a homestead not exceeding \$3,500.

**HOMESTEAD:** For purposes of this article, "homestead" shall have the same meaning as defined in 36 M.R.S.A. § 5219-KK(1)(C). Generally, a homestead is a dwelling owned or rented by the person seeking tax assistance under this article or held in a revocable living trust for the benefit of that person. The dwelling must be occupied by that person and that person's dependents as a home.

**QUALIFYING APPLICANT:** A person who is determined by the Town Manager or his designee, after review of a complete application under § 4 of this chapter, to be eligible for a refund payment under the terms of this article.

**HOUSEHOLD INCOME:** Total household income as determined by the total adjusted gross income reported on the applicant's most recent income tax return, plus the total adjusted gross income of each additional adult member of the household if filing separately.

**RENT CONSTITUTING PROPERTY TAX:** Fifteen percent (15%) of the gross rent actually paid in cash or its equivalent during the tax year solely for the right of occupancy of a homestead. For the purposes of this article, "gross rent" means rent paid at arm's length solely for the right of occupancy of a homestead, exclusive of charges for any utilities, services, furniture, furnishings or personal property appliances furnished by the landlord as part of the rental agreement, whether or not expressly set out in the rental agreement.

### SECTION 305.3 – CRITERIA FOR PARTICIPATION

In order to participate in the property tax assistance program, an applicant shall demonstrate all of the following:

- A. ~~The applicant shall be 70 years of age or more at the time of application.~~
- B. The applicant shall have a homestead in the Town of Gray at the time of the application and for the entire year prior to the date of application.
- C. The applicant has been a resident of the Town of Gray for at least 10 years immediately preceding the date of application for participation in the Program.
- D. The applicant shall own no more than one property at the time of application.
- E. The applicant shall meet the application and eligibility criteria set forth in §§ 4 and 5 of this chapter.
- F. The applicant must have applied for and received the State of Maine Property Tax Fairness Credit.

The applicant agrees to repay the tax when their property is sold or the ownership is transferred.

### SECTION 305.4 – APPLICATION AND PAYMENT PROCEDURES

- A. Persons seeking to participate in the property tax assistance program shall submit an application to the Town Manager no later than August 1 of the year for which the refund is requested. Applications are required for every year the applicant seeks to participate in this program. The application form for the program shall be made available upon request in the Town Manager's office and shall include, at a minimum, the applicant's name, homestead address and contact information. Attached to all applications shall be proof of household income.
- B. Applicants shall also submit proof of property taxes paid or rent constituting property taxes paid during the tax year on the individual's homestead in the Town of Gray.
- C. The Town Manager or his/her designee shall review and determine if the application is complete and accurate and if the applicant is otherwise eligible to participate in the program. The Town Manager or designee shall notify an applicant if an application is determined to be incomplete. The Town Manager's decision on eligibility to participate in the program shall be final.

### SECTION 305.5 – DETERMINATION OF ELIGIBILITY AND AMOUNT

If the Town Manager or designee determines that the applicant is eligible to participate in the program, he/she shall determine the total amount of such eligibility in accordance with the following formula. Eligibility under this article shall be proportional to the applicant's income in relation to the

applicant's rebate benefit base.

For purposes of calculating eligibility under this article, the applicant's income shall include total household income, and the rebate benefit base shall not exceed \$3,500, regardless of actual property taxes accrued or rent constituting property taxes accrued. Applicants with household income greater than an amount equal to 50% of the current U.S. Department of Housing and Urban Development metropolitan area median family income shall not be eligible for a rebate benefits under this article.

Notwithstanding the following formulas, the maximum rebate benefit allowed under this article shall be \$500. Eligibility shall be the lesser of the following amounts:

- A. Fifty percent of the amount by which the refund benefit base (not to exceed \$3,500) exceeds 5% of the applicant's household income (not to exceed 50% of the current HUD MFI for the Portland metropolitan area). (Note: 2019 HUD median family income (MFI) for the Portland is \$93,000 which would make the maximum income limit for eligibility \$46,500.)
- B.  $(\text{Rebate Benefit base} - 5\% \text{ of Income}) / 2 = \text{Rebate Benefit Amount}$

An amount proportional to the available monies as approved by the Town Council in the Town's annual budget and the applications received for that application year, calculated as a percentage of the refund benefit amount for which the applicant is eligible in § 5(A)(1).

#### **SECTION 305.6 – LIMITATIONS ON PAYMENTS**

- A. The Town Manager shall report to the Town Council for its approval each year the projected payments and number of eligible applicants requesting assistance from the program fund. This report shall be no later than at its second meeting following the August 1<sup>st</sup> application deadline.

Payments under this article shall be conditioned upon the existence of sufficient monies in the program fund the year in which participation is sought. If there are not sufficient monies in the program fund to pay all qualifying applicants under this article, payments shall be limited to the amounts available in the fund and may be prorated accordingly. In the event that a lack of funding results in no payment or less than the full payment to a qualifying applicant, the request will not carry over to the next year.

#### **SECTION 305.7 – CREATION OF PROGRAM FUND**

The program fund from which payments shall be made under the terms of this article shall be created as follows:

- A. As funds are available, the Town Council shall annually appropriate monies from the general fund or other sources to support this program.
- B. Any surplus monies available after all payments have been made shall be carried forward within the fund to the next fiscal year.

additional funds that may be received by dedication, gift, donation, or by supplemental

appropriation as may be approved.

#### **SECTION 305.8 – TIMING OF PAYMENTS**

A person who qualifies for payment under this program shall be mailed a check for the rebate benefit amount for which he/she is eligible under § 5 no later than ~~fourteen (14)~~ Thirty (30) calendar days from the date of Council approval of the applications for the year in which participation is sought.

#### **SECTION 305.9 – ONE APPLICANT PER HOUSEHOLD**

Only one qualifying applicant per household shall be entitled to payment under this program each year. Eligibility shall be determined based on total household income. The right to file an application under this article is personal to the applicant and does not survive the applicant's death, but the right may be exercised on behalf of an applicant by the applicant's legal guardian or attorney in fact. If an applicant dies after having filed a timely complete application that results in a determination of qualification, the amount determined by the Town Manager shall be disbursed to another member of the household as determined by the Town Manager. If the applicant was the only member of a household, then no payment shall be made under this article.

#### **LINKS and other considerations**

This is not an exhaustive list, but here are some other communities tax rebate programs that are different from ours.

##### **Saco Seniors work off the tax credit by volunteering**

[https://www.sacomaine.org/departments/assessor/senior\\_tax\\_relief.php#:~:text=Recipient%20of%20a%20Maine%20Property%20Tax%20Fairness%20Credit.,September%201%2C%202020%20for%20the%202019%20Tax%20year.](https://www.sacomaine.org/departments/assessor/senior_tax_relief.php#:~:text=Recipient%20of%20a%20Maine%20Property%20Tax%20Fairness%20Credit.,September%201%2C%202020%20for%20the%202019%20Tax%20year.)

##### **Falmouth has more criteria regarding income to qualify**

<https://www.falmouthme.org/home/pages/senior-tax-relief-program-0>

---

Pivot

\*O/F/C

(All)

OPEN

Count of Description	Column Labels			
Row Labels	H	L	M	Grand Total
Administrative	4	1	2	7
Budget	1			1
Committee			1	1
Comp. Plan Implementation	1			1
Economic Development		1		1
Open Space / Conservation Plan	1			1
Ordinance		1	17	18
Policy			1	1
Recreation			1	1
Residential		1		1
TIF Goal / Budget	1			1
Traffic	1		3	4
<b>Grand Total</b>	<b>9</b>	<b>4</b>	<b>25</b>	<b>38</b>

\*O/F/C

(All)

CLOSED

Count of Description	Column Labels			
Row Labels	H	L	M	Grand Total
Administrative	3	3	5	11
Budget			2	2
Comp. Plan Update	1			1
Comp. Plan Update - breakout of tasks for Item 11	3			3
Comp. Plan Update/ Conservation Plan	1			1
Joint Leaders	1		2	3
Ordinance	6	1	9	16
TIF Goal / Budget	2			2
Traffic - MTA			1	1
Traffic - MTA - break out tasks for Item 24B			1	1
<b>Grand Total</b>	<b>17</b>	<b>4</b>	<b>20</b>	<b>41</b>

Open

*Status: O = Open C = Closed F = Future		Priority: **H = 1-3 months M = 4-9 months L = 10+ months - Guideline			Last Update: 01/05/21							
No	Goal/Category	O/ F/C	** Pty	P No.	Target Date	Description	Sub by:	Owner:	Assigned to:	Dated Logged	Last Update	Comments
27	Open Space / Conservation Plan	O	H	1	02/01/21	During the Libby Hill Trails clean-up after the October storm, the Community Endowment communicated concerns regarding the longevity of the current ad hoc agreements used to create Libby Hill Trails. Council agreed a full review and updates are needed to protect this asset as part of Open Space Plan.	Sandy Carder	Deb Cabana	Dan Maguire	03/20/18	01/05/21	TC discussed at 3/20 meeting based on feedback received from Community Endowment. Deb advised the agreements just "came together" and are in need of review/update. Deed research - who has access to which pieces of land, how large of an geographic area is involved, how deep does the research need to go, consultation from a conservation expert - will all be needed and cost money. Council agreed to log with a target of year end, for Staff to review & determine what is needed with an estimated cost, for consideration in next year's budget. Carl Holmquist is willing to provide some names of conservation experts who can assist the Town. (12/20) Issue came up in Open Space Staff meeting - Deb working on pulling together cost estimate for budget meetings. (2/5) TC agreed to move up & tie to H2.1 Open Space. (3/21) est provided at budget meeting. Council agreed to add to budget (6/11) Residents approved budget. (10/15) Community Endowment has requested an info sharing meeting with Town Staff, 1 Councilor and an MSAD representative to start process of long term maintenance agreement. Council appointed Dan to attend. (11/12) 1st meeting went very well - 3 parties agreed preserving is paramount. (12/3) Council agreed to add annual maintenance to budget spreadsheet. (12/17) 2nd meet focused on budget - MSAD 15 conducting full audit of usage to determine impact - some easement discussion. (1/21) Deb followed up with MSAD15. No update. (2/4) Carl present to School board this week, Craig has some initial data on usage (3/10) Meet held to continue discussion - working through maintenance/budget needs. Council agreed to add the Homestead Acres issues submitted by residents on this private road - to ensure we keep them in the loop as the agreement moves forward. (6/16) Deb will check with Dr. King on next meeting after the election. (8/4) Dan adv MSAD15 lawyer provided framework agreement for review. (10/6) Dan shared a worksheet created to gather input from stakeholders. Council provided gen feedback on form. (10/20) Council prov feedback on worksheet (10/22) Meeting held to compile worksheet info. Next Step: Follow up meeting set for 1/6.
24C	Traffic	O	H	2	12/31/20	Route 26/North Raymond Road Intersection project has reached "project design" status. Need to ensure Town's input & resident concerns are included in plan as it moves forward. Deb advised this is a different MDOT group than the 24A item. MDOT TASK = awaiting "plan impact complete" from consultant to proceed with title research / acquisition phase	MDOT	Deb Cabana	Deb Cabana	04/03/18	12/15/20	DOT forum was 9-16 delayed 2. Issue -Mill Bk culvert & miss sidewalks raised DOT see more \$\$ for culvert. Forum held 5-31 Council rev notes from Forum. Council id 4 top prior. Deb to req drop dead date for proj & target to prov into req. DOT prov initial feedback & ans final ques. 8/7/18 meet. Council conf their support of current plan w/ change to expand Mill Bk culvert for future sidewalks at an addtl cost of \$5,000. Doug asked DOT to put conduit under new inters to facilitate crosswalks - DOT adv easier now to add later when needed. Council reprior to monitor proj with follow-up Circle K issue & MDOT timeline. Doug adv transf easement from DOT to Town has been sugg as 1st step in Circle K resolution. 10/2 - Dan req a timeline/checklist for DOT proj to better understand overall approach to proj's. (11/27) Deb has req timelines & DOT resp. (1/22) Deb read resp from DOT-data lag, costs & proj safety all come into play in approach. decision-adv roundabout has not worked as well as expc. Dan advised he was talk about another one, but the process is the same. (2/5) Deb adv no progress has been made with Circle K access. (3/5) Sandy adv a resident had pointed out the green garage has some historical value, referred to the GIS. (3/21) Doug adv of a possible need to increase the size of the pipe at intersection in anticipation of a stormwater fix on N. Raymond Rd. Council wants verification that proposed correction is feasible and set on costs for increase size. (5/7) Council voted to use TRF funds for upgrade. (6/18) MDOT prov update & Council prov guidance. (9/3) Doug/Deb prov update on Circle K prop (10/1) Dan adv Circle K had rec'd apprvl for their plan new curbed with ques remain. (11/12) MDOT to accept lowest bid even with 20% overage. (12/3) Kathy agreed to fol up with Circle K - done 12/5. (12/17) Council dis note from resident regard detour routes on Marjberry. (1/7) Sandy ask Deb to reach out to MDOT to set meet present on construction phase. (3/10) Staff has inv Cir K & will follow-up (4/28) MDOT prov upd- Circle K Issue still in works (6/16) Proj underway. Circle K reach out to Town (9/1) weekly updates prov & new end date 10/15. Circle K has purchase agree for abut property. Vacant buildings need to be addressed. (9/15) Dan advised Pg ext curb cut date to 11/15 prov base paving is done by end of Oct (10/20) Issue with sh rd circle K entrance disc (11/17) Most const is done incl circle K (12/1) Council agreed to Thank You letter creation. (12/15) Council approved thank you letter. Deb also pointed out there is not much room for pedestrians on one side of Shaker - room for future sidewalks was part of the plan, but the Council will need to budget for those sidewalks. Next Steps: Awaiting sign control box, signage and final touches.

\*Status: O = Open C = Closed F= Future Priority: \*\*H = 1-3 months M = 4-9 months L = 10+ months - **Guideline** Last Update: 01/05/21

No	Goal/Category	*O/ F/C	** Pty	P No.	Target Date	Description	Sub by:	Owner:	Assigned to:	Dated Logged	Last Update	Comments
84	Comp. Plan Implementation	O	H	3	<a href="#">Detail Tab</a>	Identify steps/ create plan to implement newly approved <b>Comprehensive plan</b> . <b>SEE SEPARATE TAB - FOR DETAILS</b>	Council	Council	Council	12/01/20	<a href="#">01/05/21</a>	(12/1) Council agreed to close old item and create new implementation plan. Detailed tasks will be logged on detail tab pending schedule workshop to review them and come up with timeline/prioritization. Council agreed with Dan's suggestion to ask each Committee to review CP to ID what would inform their work, how they can support implem, what roadblocks exist, what resources will be needed, etc. with a one page summary due by 2/8 for Council to review at 2/16 meeting. <a href="#">See Detail tab for updates</a> . <b>Next Steps: Schedule TC workshop - review Comm summaries 2/16.</b>
34	TIF Goal / Budget	O	H	4	<a href="#">Detail Tab</a>	Work on <b>planning</b> associated with new <b>Village TIF</b> . <b>SEE SEPARATE TAB FOR DETAILS</b>	Council	Deb Cabana	Doug Webster	08/07/18	<a href="#">01/05/21</a>	Councils agreed to close 'TIF creation' task as it is now in approved. This new item will capture the planning and additional work associated with administering the new TIF. Project was discussed during 9/10 workshop & Mr. Lavallee advised video work was still outstanding, but felt he would be able to present at 2nd Oct meeting. 9/18 Deb advised that there was still one piece left to complete. Review of M/DOT/Town video work & analysis to be presented at Dec 4th meeting (as presentation was delayed from 11/13 meeting). (11/28) Council reviewed updated info on projects with Steve, as well as his priorities. Mixed Use options were discussed at length. (12/4) Will Haskell & M/DOT provided updated info on Main Str Project. (2/5) & (2/19) See new detail tab H3. M/DOT has advised change in Main Str project timeline. (7/2) Workshop held (8/6) 7/1 Workshop minutes approved (10/15) Council agreed time to set up another brainstorming session - likely on Route 115 road - agreed to wait until 10/28 workshop to schedule so Bruce would be included. (10/28) Public forum set 12/5. (11/12) Dan will facilitate - Council agreed to set up/format. <a href="#">See detail tab for updates</a> . <b>Next Steps: Doug to work up proposal on Zoning once time allows. Council discussion funding options.</b>
1	Budget	O	H	5	12/01/20	Installation of <b>LANDFILL Solar Arrays</b> on Town Property.	Sandy Carder	Sandy Carder	Revision	01/02/18	12/15/20	There are financial costs assoc with a solar array. Deb has obtained copies of 50 Po RFP and set up meeting with Cumberland & Town Staff to review (3/22/18). Also, Deb has advised Gray has a new 5 yr electricity contract - which was renewed in 2017. Deb provided Sandy with some info from Cumberland. Deb & Sandy along with Town Staff attended Solar Array tour in So. Portland. Sandy gave overview of some info provided by Cumberland & So. Portland & advised there are some IB students/readers willing to do some leg work for us. Also, So Po cost was approx \$17,000 up front. Sandy met with Steve Wystrom at HS on 11/15. (1/8) Sandy spoke to Tony Plante & he advised Windham has solar on fire station (and it has exceeded expectations) & is still working on landfill option C/ed person handling. In addition, SoPo is leading a community group to advocate for environ. changes & Council agreed to have Deb reach out on behalf of Gray. (1/22) Sandy advised Windham is interested in staying in the loop as they are at the same point as Gray & may be will to partner. (2/5) Deb & Sandy attended Kennebec Water Treatment Solar Array event - spoke to Revision Rep & advised they do Prelim review to ensure landfill meets minimum requirement and that they evaluate ALL Town property in their bids. (2/19) Sandy advised Revision has target date of end of Feb. (3/5) Nick provided options in meet w/ Town Staff & Sandy. (3/19) & (4/2) Addtl info prov (4/16) Sandy adv Windham is not able to participate at this time. S/AD rec'd material, await meet, RFP ex rec'd, reconpre not an issue. (6/4) updates prov (7/2) Options/updated rev at workshop. Maj of Council supports proceed with an array on the landfill. (8/6) Sandy prov updates from MSAD15 Facilities meeting. Straw poll taken with majority in support of intent with Revision in lieu of RFP - unless MSAD15 requires RFP. (9/3) MSAD meet 9/4 (9/17) Sandy advised MSAD needs more time. (10/1) LOI executed, site walk done. (10/15) Council voted to accept executive PPA summary & proceed with the project. (11/12) Council approved PPA contract. (12/17) Revision dropped KWH rate due to savings - Council approved PPA amendment. (3/10) PB req clarification on applicant status - Council appr Revision as agent of town. (4/21) Kathy expects sub 4/22 for next PB meet. (4/28) Kathy adv app rec'd & site walk set to address some minor issues. (8/4) Council appr easement. (10/6) prog shared & Sandy adv of new PUC app CMP/Telephone fees. (11/17) Council app PPA Amend (12/15) Deb advised she has officially signed the agreement with the new owner of the Solar Array - Wish Camper LLC. <b>Next Step: Construction is complete - awaiting CMP to turn on array.</b>

\*Status: O = Open C = Closed F = Future \*\*H = 1-3 months M = 4-9 months L = 10+ months - **Guideline** Last Update: 01/05/21

No	Goal/Category	*O/ F/C	** Pty	P No.	Target Date	Description	Sub by:	Owner:	Assigned to:	Dated Logged	Last Update	Comments
66	Administrative	O	H	6	12/31/20	Determine if "No Thru Trucks" restriction should be placed on a section of Mayall Rd	Dan Maguire	Council	Dan Maguire	11/22/19	01/05/21	Back in June, Kathy Taylor (Mayall Rd resident) had reached out to all Councilors regarding the state of her road and the heavy truck traffic. Dan spoke to her directly and agreed to manage the request. This road was set to be paved, but dropped from PW's schedule due to paving costs being substantially higher than anticipated. It will be at top of the list next cycle. Deb did some initial feedback - as this section of road is being considered for "state aid" designation (Depot Rd is a state aid road). This impacts cost sharing/responsibility with MDOT vs. local. MDOT was conducting vehicle counts for the road for Deb/Steve had req'd. Dan also advised Ms. Taylor that talking to her neighbors on the road to determine the level of support for posting "no thru trucks" would be helpful. (11/7) Dan rec'd an official petition signed by 24 Mayall Rd residents. (11/12) Council agreed to add to tracking spreadsheet - it was set to be discussed at 12/3 Council meeting already. (12/3) Sandy provided more info on options incl. weight limits. Deb advised of possible "State Aid" classification (12/17) Deb provided proposal from GRP - \$1,000 to determine if Mayall/Meymouth would even qualify - Council expressed concerns on impacts to road maintenance and residents. (1/21) After rev expenses & discuss control concerns, Council agreed NOT to pursue state aid status on either road. Can revisit at later date. Discussed possibly just putting up signs, but felt more info was needed & did not want to set up false sense of enforcement. (2/4) Dan notified resident & adv. it would take time before a workshop could be scheduled. Council agreed to send feedback on LD1498 in support of MMA testimony against bill to eliminate weight limits on rural roads. (2/18) Council app letter. (4/28) Dan adv. Resident checked in again, but understood delay. (6/16) Dan req. Council consider posting signs again (7/21) Council discussed & agreed need to pull in Depot Rd residents. (9/1) Council set 10/6 for workshop prior to TC meeting. (10/6) Public forum held with info sharing. (10/20) Council disc options (12/1) Dan has done some research to share with Sandy. MDOT has approved the 4 way stop. (12/15) Dan & Sandy held discussion. Dan updated Council. (1/5) Dan adv MDOT has sample ord see #77. <b>Next Step:</b> Construction underway. Dan will draft a letter to send to commercial businesses.
75	Administrative	O	H	7	03/01/21	Address ATV access issue on Long Hill Road	Deb Cabana	Anne Gass	Council	05/05/20	01/05/21	(5/5): Council designated Long Hill Road as a 1 year temporary ATV access road in Sept, 2018. Residents submitted complaints about the usage starting in Aug, 2019. Council rec'd additional feedback from residents at various meetings including the suggestion to reclaim an old ATV connection trail as a replacement to the LH use. The ATV Club presented the Council with their plan of action to mitigate the issues brought forward by the residents on 3/10/2020. Council discussed at the 4/28 meeting and agreed to log at 5/5 meeting. General consensus is a temporary access will be granted again while Councilor Gass works with the ATV Club to develop a plan to reclaim the old ATV trail and funding options. (5/19) Council agreed to temporary access with mitigating measures, develop of long term trail solution and monitoring of complaints. Anne agreed to take the lead to work with the Club to apply for a grant. (6/16) Anne adv that the grant program is the same that was used to build the tennis courts at the HS. Those courts were not maintained & eventually removed for add'l parking. The Town has been working to provide a comparable recreation facility to replace the tennis courts - but each has fallen through. The alternative is to pay back the original grant. The grant program is off limits to the Town until this is resolved. (8/4) Kathy T discussed status with State. Anne adv there is an outside chance some work in NG may help. She also adv there is another grant but not until Spring. Jan provided update from ATV - no new complaints. Council extended access through the end of the season. (11/17) Council disc with Doug Beck. (1/5) Anne has found alt grants - Apr/May deadline. <b>Next Steps:</b> Anne setting up meeting with John Powers from ATV Club.
55	Administrative	O	H	8	12/01/20	Review current legal agreement between MDOT, Water District and Town regarding the Route 26A winter maintenance and wellhead monitoring	Deb Cabana	Deb Cabana	Council	04/16/19	12/17/19	The MDOT has advised they intent to "NOT" renew the legal contract binding them to provide winter maintenance and wellhead monitoring on the Route 26A and wish to turn those responsibilities to the Town. Deb also advised that the last round of MDOT testing found elevated salt level in the testing wells. The current agreement clearly states the MDOT is responsible for addressing those elevated levels; however, they are disputing the cause. (9/3) Executive session held (12/17) add'l Executive session held - Council took no action. <b>Next Steps:</b> Future Executive Session to be scheduled.

\*Status: **O** = Open **C** = Closed **F** = Future **Priority:** **\*\*H** = 1-3 months **M** = 4-9 months **L** = 10+ months - **Guideline** Last Update: 01/05/21

No	Goal/Category	*O/ f/c	** Pty	P No.	Target Date	Description	Sub by:	Owner:	Assigned to:	Dated Logged	Last Update	Comments
56	Administrative	O	H	9	02/01/21	Develop official Job Description, Appraisal Form/process & Search Plan for the Town Manager position	Council	Sandy Carder	Council	04/16/19	01/05/21	Council agreed to outline of needed tasks to address the end of the Town Manager's current contract which expires in 2021. (6/18) Deb has been collecting some examples and working with Suzanna to create a list of current responsibilities. (7/2) Council discussed & agreed to each identify top 5 Responsibilities and top 5 Characteristics. (8/6) meeting ran long so Council agreed to send info to Sandy to consolidate for next meeting. (9/3) Sandy did not rec submissions from all councilors in time for discussion - would like by 9/6 to send to Deb for 9/9 deadline. (9/17) Sharon chose not to participate as she felt the header hunter the Council hires should inform the Council of the Resp & Char. The remaining Councilors reviewed the submissions and agreed to summarize. (10/1) Council had no issues with completed version - although Anne had some small edits. (10/15) Sandy advised Freeport has some salary survey info they are willing to share (via GPCOG meeting). (10/28) Sandy provided info from Freeport to Council. (12/3) Council agreed this needs to move up in priority and need to work on all three items. (2/18) Council discussed budget for search consultant. (6/16) Council set up workshop (7/21) Council did first review of tasks. Sandy to compile. LDI failure prevents search from starting. (8/4) Council rev outstanding ques. identified add'l changes, identified need for Charter changes, req quotes on search (9/15) Budget passed. Council rev 3 proposals - agreed that was plenty & id a couple add'l ques (10/6) Council voted to hire Eaton Peabody. (11/17) Ad app'r & posted. Applications being rec'd (12/1) public forum & dept. head interviews completed. App deadline is 12/3. Don to send binders to Sandy. (12/15) Council holding 1st round of interviews. (1/5) Council has selected 2 candidates to adv to 2nd round. Next Step: Don to facilitate interviews with Dept Heads (1/6) & Council will then hold 2nd interviews (1/8)
24A	Traffic	O	M	1.1	<a href="#">Detail Tab</a>	Based on TC meeting with State Representatives and Senator, identify action items to pursue both short term & long term. We will keep NG informed of our meetings/progress so they may attend, if they chose. <b>SEE SEPARATE TAB - FOR DETAILS</b> <b>MDOT Portion.</b>	Council	Council	Sandy Carder	02/22/18	01/05/21	Councilor Carder created meeting notes from Workshop (1/29), Councilor Foshay pulled action items to create list. Logging working list item to capture review/prioritization effort by Council. New individual items will be logged as needed. Council discussed at 3/6 meeting & agreed to set up separate meetings with MTA/MDOT - with a target date of end of April/beginning of May - MDOT - prior to a TC meeting 5:30pm start time. That will allow 90 minutes to discuss. TC agreed shaker - (1) old R226 vs by-pass (2) in village around island (no sign again) (3) Depot rd RR Xing would be priority 4. Kyle also advised he will look into signage (1) & (2). Deb requested target date & CC State Reps/Senator. Deb spoke to MDOT advising of RT 26 bridge closure - suggesting it may be a good time to consider remaining Route 26. Deb advised a MDOT/Staff meeting was held (1) traffic movement permit at 97 shaker (2) closing shaker rd bridge MTA work (3) village island (4) rt 26 routing were discussed. (12/4) MDOT provided some info at Council meeting (3/5) Sandy pulled down new workplan & sent to Councilors. (6/16) Rob Betz, Patrick Adams & Steve Cole from the MDOT attended a workshop with the Council to review various projects in process. in planning & on the future list. Patrick offered to come to Gray to do a walkthrough of all the various streets to obtain more information on the issues. (7/21) Walkthru set up 8/5. Next Step: See Detail tab for more info. Awaiting response from Rob Betz.

\*Status: O = Open C = Closed F= Future  
 Priority: \*\*H = 1-3 months M = 4-9 months L = 10+ months - **Guideline**

Last Update: 01/05/21

No	Goal/Category	*O/ F/C	** Pty	P No.	Target Date	Description	Sub by:	Owner:	Assigned to:	Dated Logged	Last Update	Comments
248	Traffic	O	M	1,2	<a href="#">Detail Tab</a>	Based on TC meeting with State Representatives and Senator, identify action items to pursue both short term & long term. We will keep NG informed of our meetings/progress so they may attend, if they chose. <b>MTA Portion.</b> <b>SEE SEPARATE TAB - FOR DETAILS</b>	Town Council	Town Council	Sandy Carder	02/22/18	<a href="#">01/05/21</a>	Councilor Carder created meeting notes from Workshop (1/29), Councilor Foshay pulled action items to create list. Logging working list item to capture review/prioritization effort by Council. New individual items will be logged as needed. Council discussed at 3/6 meeting & agreed to set up separate meetings with MTA/MDOT - with a target date of end of April/beginning of May -MTA - set up workshop in May - Peter Mills, Bruce Van Note - to open discussions based on Bruce's list. Added Dan's items - revenue sharing, gifting property & dual access curb cuts. Meeting held Mary 24th. See separate tab for details. Deb requested update and MTA has sent back initial feedback. Council discussed feedback & add'l info from Deb. Discussed possibly sending official letters to individual trucking companies regarding avoiding Village rd6, concerns from MTA about trucks not seeing closure signs and diversion study next steps. Council Maguire suggested inviting a MTA planner to future meetings: (12/4) MTA provided info on diversion study. <b>Next Step: Council to provide add'l feedback to Deb, MTA to reach out to other partners. See detail tab for more info.</b>
46	Ordinance	O	M	2	12/31/20	Develop <b>Growth Management</b> strategy - as part of Comprehensive Planning & to allow needed time for Open Space Planning	Sandy Carder	Deb Cabana	Doug Webster	02/05/19	09/01/20	(1/22) Dan advised PD does not feel any additional action is needed at this time. Growth Cap was discussed and Town Staff will look into with OAC and bring forward when ready. A growth cap has been discussed in various meetings for the last year (or more). Not having a robust growth plan and/or cap was one of the primary reasons the original Comprehensive Plan was not approved. (1/30) During the Open Space forum, Alan & Lucky both strongly encouraged a growth cap be discussed/implemented as soon as possible to provide Gray with more time to develop an Open Space plan. In addition, issues with current residential sub-division ordinances, duplex allowances, and limited safeguards against a large scale development need to be addressed. Kathy advised Town Staff have crunched annual data and Doug advised developing one would be rather straightforward & would be padded to avoid impacting wanted economic & residential development. (2/19) Council agreed this is a top priority now. (3/5) Doug reviewed steps (1) Verify current comp plan (2) check with legal ordinance (3) implement verifying data supports number selected & Council provided direction. (6/4) Doug provided some data and Arundui ordinance (left in 1977). Council agreed to proceed cautiously. (9/3) Doug advised best 1st step would be to discuss possible 'cap' number and process to apply caps. (10/1) Council workshop held - guidance provided to Doug. (1/21) Council would like to have some info to discuss by the 2/18 meet given the push on larger developments & Comp Plan process. (2/4) OAC looked at & were not in support - worried about administration of the process impacting staffing (2/18) Council discussed changing approach to be more comprehensive to focus on Growth MANAGEMENT vs just a cap. Need to coordinate with the comprehensive plan timeline as an approved plan is required to enforce growth permit systems. (3/10) OAC began work on this item. (5/5) OAC wants to coordinate with Comp Plan so work will not start now, however, due to the need for Council work as well, draft options still to be delivered by end of summer to stay in line with CP. (8/4) Council disc at 8/4 workshop to confirm a full workshop for this along with the duplex/OAC ordinance list can be discussed (9/1) Council disc OAC document cover duplexes, multi unit housing, growth & comp plan info - agreed add'l workshop to create workplan to complete all the work needed. <b>Next Step: Council needs to schedule follow-up workshop &amp; need to await voter approval of Comp Plan.</b>

*Status: O = Open C = Closed F = Future		Priority: **H = 1-3 months M = 4-9 months L = 10+ months - Guideline		Last Update: 01/05/21								
No	Goal/Category	*O/ F/C	** Prv/ No.	P	Target Date	Description	Sub by:	Owner:	Assigned to:	Dated Logged	Last Update	Comments
4	Traffic	O	M	3	06/01/21	Work to develop long term changes needed to address traffic, drainage, road conditions, pedestrian & cyclist safety and speed along Route 115 entering Gray from the hill thru connection to Brown Street.	Deb Cabana	Council	Council	01/02/18	01/05/21	During the June Council meeting, Town Staff advised they would be pursuing a M/P grant for reconstruction of this stretch of road in collaboration with the MDOT. It was advised that this would likely be a 2 year process with updates provided to the Council. Deb Cabana noted that this would be a 50/50 split for costs (not 25/75 Town/MDOT as previously stated) and includes replacement of the water main. Therefore, it may be included in the upcoming TIF creation, thus it should remain active (rather than 2 year target). Reference material: Pavement Conditions Study - Dec 2017. Project discussed in 9/10 & 11/28 TIF workshops, as well as in TC meetings. (12/4) TC would like to see a review of intersections done prior to committing to a 115 solution or as part of the engineering of that project - to ensure project does not hamstring options (5/7) Deb advised several communications received regarding pedestrian fatality on Rt 115 requesting sidewalks. (9/3) Sandy adv of outstanding question - need for possible budget consideration (9/17) Deb verified with Will that M/P does not require engineering completion - however - Ann verified the Town's piece of the budget must be approved & set aside to apply, Dan also advised a 50+ sub division (apartment buildings) is before the PB for this road & stormwater/sidewalks are being discussed. (10/15) Deb adv Stevie/Will met with DOT & have more info. (10/28) Council set up public forum 12/5. (11/12) Dan will facilitate & council discussed format (12/5) Public Forum held. (12/17) Council agreed 1st forum very successful, data compiled, next step is to work out starting point on proj. (1/21) Council held workshop with Water Distr about Route 100 TIF and this proj was select by both grps as the best proj. (2/4) Deb adv Alyssa said it is possible to amend rt 100 TIF for this proj but needs to talk details with us. (3/10) Council & WD agreed to amend TIF to ind this proj (4/28) Council rev warrant art (6/2) Council held public hearing & voted to approval TIF amend (7/21) Voters approved revision. (10/6) State submission done. (12/1) TIF amend appr. <b>Next Step: Council workshop set for 1/19</b>
61	Ordinance	O	M	4.1	12/31/20	Review gas station standard within Sign Ordinance	Doug Webster	Deb Cabana	Doug Webster	07/02/19	01/05/21	(7/2) Issue came up after the Cumberland Farms CZA negotiations and was swept into sign ordinance discussion for Maine Wildlife Park. Looking to update gas station sign standards to better address new technologies and ensure continuity within zones with aesthetics in mind. OAC has a meeting scheduled for 7/10. (3/10) OAC working on as add'l issue continue to come up. (6/16) Doug advised the amendments to the Sign Ordinance should be ready for Council discussion at the 7/21 meeting. (8/4) Doug adv OAC should be finalizing in next meeting. (9/1) Council reviewed some of sign ordinance changes - need workshop to finish. (10/6) Dan provided updates (10/20) Council prov feedback on good chunk of ordinance. <b>(1/5) Council finalized feedback. Next Step: Doug to update language. resolve illumination standard with goal of 2/16 for 1st reading &amp; public hearing.</b>
62	Ordinance	O	M	4.2	12/31/20	Review 'multi-tenant' standard within Sign Ordinance for Plaza (Village Zones)	Doug Webster	Deb Cabana	Doug Webster	07/02/19	01/05/21	(7/2) Issue came up with changes at the Plaza and was swept into sign ordinance discussion for Maine Wildlife Park. Looking to update multi tenant sign standards for Village Zones to help prepare for possible relocation to NGRH. OAC has a meeting scheduled for 7/10. (3/10) OAC working on as add'l issue continue to come up. (4/21) OAC asked Council for some guidance regarding possible light options and design standards. Council were open to considering changes. (6/16) Doug advised the amendments to the Sign Ordinance should be ready for Council discussion at the 7/21 meeting. (8/4) Doug adv OAC should be finalizing in next meeting. (9/1) Council reviewed some of sign ordinance changes - need workshop to finish. (10/6) Dan provided updates (10/20) Council prov feedback on good chunk of ordinance. <b>(1/5) Council finalized feedback. Next Step: Doug to update language. resolve illumination standard with goal of 2/16 for 1st reading &amp; public hearing.</b>

*Status: O = Open C = Closed F = Future		Priority: **H = 1-3 months M = 4-9 months L = 10+ months - Guideline			Last Update: 01/05/21							
No	Goal/Category	*O/ F/C	** Pty	P No.	Target Date	Description	Sub by:	Owner:	Assigned to:	Dated Logged	Last Update	Comments
72	Ordinance	O	M	5	12/31/20	Update Fireworks Ordinance to address Chinese Lunar New Year celebrations	Deb Cabana	Council	Deb Cabana	02/04/20	01/05/21	(1/21) Council reviewed request from local business to approve the use of Firecrackers to celebrate the Chinese New Year. Council approved but agreed if it is an annual event, the fireworks ordinance should be modified as needed. (2/4) Council agreed to add to tracking spreadsheet & Deb advise the correct terminology is Lunar New Year which can change dates. (7/21) a couple other issues were mentioned in 7/21 meeting - July 4th schedule, variance for CL Association to use propellant gun to address geese issue based on recommendation by IF&W. (9/1) Alyssa is checking to verify the propellant gun is actually consider a firearm. (10/6) Sharon shared info she obtained by contacting a State biologist about options for controlling geese and feedback on the propellant gun. (12/1) Council discussed submitted changes (1) Asian New Year addition - agreed (2) propellant gun use for geese control on CL - agreed likely not a firearm and thus not under Council purview, agreed Alyssa to finish research to confirm (3) reduction/change in July 4th dates - agreed to leave as is (4) Ban fireworks - did not support (5) new signage to assist with enforcement - agreed budget issue to be considered then, if brought forward. (1/5) Council held 1st reading/public hearing. Next Step: Deb to work with Alyssa on legal issue related to geese. 2nd reading set for 1/19.
77	Ordinance	O	M	6	TBD	Create a Traffic Ordinance to comply with MDOT standard for local signage	Sandy Carder	Council	Dan Maguire	05/05/20	01/05/21	(5/5) In reviewing the MDOT policy for posting local roads with weight limits or 'no thru truck' signs, one requirement is to have a Traffic Ordinance on the books. Council agreed to log and prioritize once more information is collected under item #66. (12/15) Dan has volunteered to draft an ordinance to help move short Mayvall Rd situation forward. (1/5) Dan adv MDOT has model ordinance. Next Step: Dan to research and bring to Council.
74	Administrative	O	M	7	12/31/20	Update Gray Historical Society lease with Town	Sandy Carder	Sandy Carder	Galen Morrison	02/18/20	01/05/21	(2/18) Sandy explained the Gray Historical Society would like to update the lease they hold with the Town. They are looking for the Town to assume utility expenses directly to allow them to do more robust fundraising/grant applications to focus on their historical work and to address more maintenance on the building itself. Right now, they are reimbursed up to \$6,000 annually - but have to pay monthly bills. (1/5) Sandy advise Galen is working on with Debi. Next Step: GHS will draft a proposed new lease and present to the Council.
83	Committee	O	M	8	07/01/21	Discuss additional requirements for quasi-judicial Boards - Planning and ZBA	Council	Council	Council	09/15/20	09/15/20	(9/15) Council discussed the need to ensure long term viability of quasi-judicial boards and ensure opportunities for new applicants - via new requirements which may or may not include term limits, application wait periods, chair rotation, mandatory MMA training, pre-training options for those thinking about joining, mentoring, rotation of alternates etc. There was also discussion related to possible changes in Council Rules once quasi-judicial rules are set.
49	Ordinance	O	M	9	01/01/21	Review current ordinances and zoning to determine if changes are needed for Duplexes	Dan Maguire	Dan Maguire	Doug Webster	02/19/19	09/01/20	Dan asked the Council to consider making changes to Duplexes to address sprawl growth and other unintended impacts to density bonus of allowing a duplex in lieu of a single unit of housing. Doug advised this issue has been researched in the past. Dan needs to talk to Kathy and then work through reviewing current ordinances. Then, bring to the OAC for possible proposal to the Council. (12/17) Deb advised of resident e-mail regarding the number of duplexes being built in Gray - Planning Board has also recently discussed. Council agreed this issue needs to be moved up in the priority list. (6/2) Council reviewed questions from OAC & provided direction. Generally speaking, there was support to make it more restrictive in certain zones and encourage them in others by making it less restrictive. It was agreed this is one tool in the growth mgmt plan. (8/4) Doug provided memo detailing OAC ques/disc points along with the growth plan disc and Comp Plan review. Council agreed a full workshop is needed to review. (9/1) Council disc OAC document cover duplexes, multi unit housing, growth & comp plan info - agreed add'l workshop to create workplan to complete all the work needed. Next Step: OAC to consider initial feedback - need another workshop.

*Status: O = Open C = Closed F = Future		Priority: **H = 1-3 months M = 4-9 months L = 10+ months - Guideline										
No	Goal/Categorv	*O/ F/C	** Prv	P No.	Target Date	Description	Sub by:	Owner:	Assigned to:	Dated Logged	Last Update	Comments
69	Recreation	O	M	10	04/01/21	Create a Pocket Park including Historical Marker at 5 Yarmouth Rd property	CEDC	Deb Cabana	Kathy Tombarelli	12/17/19	01/05/21	(12/17) CEDC representative Rachel Rumson presented plans for a new Pocket Park on the 5 Yarmouth Rd municipal property which would include a Historic Marker as part of a Historical Trail - which was presented by Galen Morrison. Council provided some initial feedback. Kathy Tombarelli advised there was a possible grant that may assist with phase 1 of the project - earthwork. (1/7) Kathy provided a draft grant application at meeting and Council provided feedback. Council agreed to add to tracking list as project is ongoing and will involve Town Staff and funding. (1/21) Council approved CDGB application. (3/10) Kathy advised the grant was recommended for funding & is moving onto the next phase. (4/21) Kathy will follow up on status of process. (7/21) Planning board reviewed & were very supportive. Abutter meeting held with great feedback. Council approved Rachel Rumson as agent for Planning board work. Due to LDI failure, grant funding now on hold. (9/1) Council discussed changes to Committee policy to address consultant work. (9/15) Council approved consultant changes to Committee rules (11/17) Council appor land exchange on site to clarify property line. (1/5) RFP has been posted. Next Step: Kathy to post for consultant for Council rev at 1/19 meeting.
37	Ordinance	O	M	11	TBD	Discrepancies between the existing Shoreland Ordinances and current State of Maine requirements/status have been identified and require updates.	Doug Webster	Deb Cabana	Doug Webster	09/04/18	01/05/21	Town Staff has identified several areas (1) DEP Bi-annual report is no longer required (2) functional needed structures are not compliant with current ordinances (3) existing set backs have some challenges. Ordinances need to be updated and brought before the Council. (4/21) Sandy advised several residents are asking the council to consider adopting the 2016 State Shoreland zoning statute (vs the existing 2005 and 1989 standards. Sandy advised Council will see on the 5/5 meeting for consideration. (4/28) Council discussed in some detail working this item in conjunction with the review of options related to the fact that Gray is currently working with the 1989 Shoreland Zoning - while 2005 & 2016 amendments have been created at the State level. Code is required to review all three, in some instances, to determine which one is most strict & apply accordingly. There are pros/cons related to all three - incl the 2005 is better for new builds, whereas teh 2016 is better for remodels/expansions. Doug also pointed out this work is the most time consuming for code enforcement & there may be a need to limit the number of applications in a given period of time to ensure resource availability. Much more work is needed. OAC to provide reprioritizing recommendations at the 5/5 meeting. (10/5) Scott D prov add'l info on differences and DEP recommendation to adopt 2015 standards. Doug adv will require some ordinance updates to implement and recommends DEP review. Council agreed to move up on priority list. Next Step: Deb is working with Scott on pulling info from other municipalities.

\*Status: O = Open C = Closed F= Future \*\*H = 1-3 months M = 4-9 months L = 10+ months - **Guideline** Last Update: 01/05/21

No	Goal/Category	*O/ F/C	** H/M/L	P No.	Target Date	Description	Sub by:	Owner:	Assigned to:	Dated Logged	Last Update	Comments
189	Ordinance	O	M	12	07/01/21	Update Current Zoning/Uses to allow Solar Arrays on Municipal property and land between by-pass and turnpike. See 188 under Medium for companion item.	Dan Maguire	Deb Cabana	Doug Webster	01/22/18	11/17/20	Several serious issues exist - traffic (MDOT major movement permit required at 100 peak hour vehicles & they have advised they will not grant) and environmental (increase costs substantially). Doug advised current tenants = 20-30 peak hour trips. After many discussions of possible options - recreational fields, self storage - no govt fits were identified (6/4) May be part of future community solar project discussion? (10/15) Town has rec'd req from commercial solar array company to use the property. (11/12) ISM Solar (Greg Lucini) presented his proposed SWM solar array project to Council with tech support from Chris Byers & Dale Knapp. CMP permit submitted, purchase agreements in place with both MDOT & private property owners. DEP, IWR&F and Gray Water Dept already brought into discussion. Issue is commercial array not permitted under current zoning/ordinances. Council recognized long term, we need a solar ordinance, but do not want to delay this project. Strong unanimous support for project from Council. Mr. Lucini is willing to work with town on any issues - including setting up an escrow account to guard against issues with decommissioning. (12/3) Kathy presented options of an overlay & Council discussed in comparison to CZA. (1/7) Kathy presented changes related to a new overlay for council feedback. (1/21) Council provided feedback on overlay proposal from Kathy/Doug. (2/4) Ph Bd has reviewed & was in support. OAC rev & had issue with set backs but was in support. Deb adv they were changed to 25 feet. Assessor will be attending day long training to obtain instructions on how to do valuations on commercial solar arrays. Deb also adv we rec'd notification of another commercial array on rt 100. (2/18) 1st Reading held. (3/24) 2nd read & public hearing held and voted as passed. (4/28) Kathy adv app rec'd and it looked almost fully completed. (5/19) Pre app app: 5/14 (8/4) Council agreed since overlay is done - now medium priority as it works through Pg/State. Item 188 policies & ordinances for solar arrays may need to move up as right now - they are not permitted anywhere outside overlay. (11/17) Kathy adv nego underway on assessment - complicated. <b>Next Step: Final application to PB</b>
70	Ordinance	O	M	13	TBD	Review current residential Subdivision Ordinance for necessary changes in Open Space	Doug Webster	Deb Cabana	Doug Webster	02/04/20	02/04/20	(2/5) Doug advised there were some critical issues that needed review within the current residential Subdivision ordinance. (3/5) OAC provided priority order of outstanding items & this was included. Also, identified "Fire Protection" adjustments and Open Space standards as items to be worked on. (7/2) OAC set for 7/10 & this is on agenda. (2/4) Originally logged as item 40 - Council agreed to split out the OPEN SPACE portion for the subdivision ordinance as a higher priority. Currently, developers are able to ID & use "unusable" property as open space to meet the standard to obtain the density bonuses. Ordinance needs to be updated to require the space meet OS standards to count towards density. <b>Next Step: OAC/Staff will provide suggested changes to Council.</b>
52	Ordinance	O	M	14	TBD	Develop local level Sidewalk Construction standards	Dan Maguire	Dan Maguire	Doug Webster	03/05/19	09/01/20	Dan brought up the possible need for local level construction standards for sidewalks after various discussions about status of existing or proposed sidewalks in budget & council meetings. (9/1) Anne provided Council with a "Green Streets Guide" shared by Lauren Meeks (Resident - MDOT engineer) who suggested it be considered when creating our sidewalk standards and during our infrastructure project planning. Dan suggested Lauren attend an OAC meeting in the future. <b>Next Step: Dan to bring to OAC for discussion - once OAC resources become available.</b>
76	Ordinance	O	M	15	TBD	Amend Subdivision Ordinance to strengthen Buffer Zone requirements & provide more autonomy to PB relating to internal roads	Dan Maguire	Deb Cabana	Dan Maguire	05/05/20	05/05/20	(5/5) Based on feedback from the Planning Board regarding the current Buffer Zone requirement being reduced from the 50 foot mandate due to the location of houses and other issues, they are asking the Council to strengthen the language in the ordinance. In addition, they would like more autonomy related to mandating internal roads vs shared driveways to reduce curbcuts and assist with the buffer zone issue. Council agreed to log. <b>Next Step: Dan to bring to the OAC for discussion.</b>

\*Status: O = Open C = Closed F = Future Priority: \*\*H = 1-3 months M = 4-9 months L = 10+ months - **Guideline** Last Update: 01/05/21

No	Goal/Category	*O/ F/C	** Pty	P No.	Target Date	Description	Sub by:	Owner:	Assigned to:	Dated Logged	Last Update	Comments
82	Policy	O	M	16	TBD	Need to review & update Town's Fiscal Policy in area of CIP funding	Dan Maguire	Council	Council	09/15/20	01/05/21	(4/9) Dan proposed we review & update the Town's fiscal policy to change CIP funding to include a bonding option for larger more long tail items (like the ladder truck) rather than attempt to include in annual payments to CIP - as long term - we will never be able to fund appropriately, nor does it make sense to pay cash for such large items. Council agreed. Needs to be brought to a Council meeting & logged on active list - after budget season. (12/15) Council discussed Budget planning at workshop. <b>Next Step: Council to discuss at 1/12 Workshops.</b>
78	Ordinance	O	M	12	TBD	Create Stormwater Standards for Watersheds	Doug Webster	Deb Cabana	Doug Webster	06/02/20	06/02/20	(6/2) Council agreed to log new item to create Stormwater standards for watersheds which will consist of (1) obtaining assistance from Cumberland County Soil & Water Conservation District (2) consideration of watershed overlay to zoning map (3) setting up add'l peer reviews for PB applications (4) creating ongoing stormwater maintenance inspections/verifications (5) creating procedure to document agreements to bind future owners to maintaining stormwater plans. <b>Next Step: OAC to provide target date and work on as resources become available.</b>
22	Ordinance	O	M	18	TBD	Review current ordinance governing stormwater drainage measurements to determine if updates are needed. Update ordinance to include licensing fee or other fee structure IF business wants access to stormwater system.	Council	Deb Cabana	Doug Webster	02/09/18	03/12/20	During the CZA process with Cumberland Farms, much discussion was centered around "peak flow" vs. "volume" of stormwater drainage & about possibly updating the existing ordinance to cover both measurements. TC discussed and need Staff direction on item, as well as priority/timeline. Doug Webster made presentation (3/6) of feedback from Town Engineer. Recommendation is update ordinance to specify licensing or fee structure to account for any future requests to hook up to Town's stormwater system. (2/5) Council discussed need to move this up to ensure work is done before MBOOT comes to redo Main Str and to ensure used in future development proposals. Doug also pointed out that results of Watershed study may impact regulations as stricter state statutes come into play. Study is awaiting Spring field work & will include detail to help. (3/5) OAC provided priority order of outstanding items & this was included. (5/21) OAC had prelim discussion at May meeting. (7/2) OAC started review - will continue at 7/10 meeting. (3/12) Staff recommend stormwater modeling be done to understand current infrastructure and recommendation for future - to anticipate add'l devel. That would inform the ordinance/fee work. <b>Next Steps: OAC/Town Staff will provide suggested changes to Council.</b>
60	Ordinance	O	M	19	TBD	Review current Kennel related ordinances, identify needed changes & update accordingly.	Deb Cabana	Deb Cabana	Doug Webster	06/04/19	12/03/19	(5/21) Council was made aware of issue via OAC meeting update. New Dog Officer has advised of conflicts between current ordinances and general residential practices. Gray also has existing Kennel businesses. There is also a State Statute involved. Everyone agreed identifying fixes to coincide with new licenses would be best way to communicate any changes. (6/4) Council agreed to move down the priority list - using license timeline as guide. (9/3) Dan advised being moved up due to timing for Dog Officer and Dog licenses. (10/1) Dan advised this one is almost complete. (12/3) Sandy suggested the OAC meet without Doug and work on what they can. Council & Deb discussed and agreed to give this approach a try with Doug reviewing work as needed. <b>Next Step: This one may be a good item for the OAC to test out new approach.</b>
188	Ordinance	O	M	20	TBD	Update Town's Ordinance to reflect long term Solar Array policies for commercial & residential, all sizes. See 18A under High Priority for companion item.	Kathy Tombarrelli	Deb Cabana	Kathy Tombarrelli	12/03/19	01/05/21	(12/3) Council agreed to split this task into two parts - the high priority to address current large scale solar array projects and the medium priority to address long term solar policies for both commercial & residential and for all size arrays. (2/4) Deb adv Mr. Boyle has entered into an agreement with Copp on Route 100 to use some of his land to build a commercial solar array. (2/18) Mr. Boyle made presentation (3/10) Council discussed next steps but will need more information from Mr. Boyle before a decision can be made on how to proceed. (12/15) Another Commercial solar array project is being proposed by Dynamic Energy on Route 115. Presentation done to Council. (1/5) Council discussed & there is consensus to move forward pending more information. <b>Next Step: Planning Dept to continue to track Mr. Boyle's project. Kathy/Doug to work on requested info with Dynamic Energy with goal to have updated presentation with recommendations at 1/19 meeting.</b>

*Status: O = Open C = Closed F = Future		Priority: **H = 1-3 months M = 4-9 months L = 10+ months - Guideline		Last Update: 01/05/21								
No	Goal/Category	*O/ F/C	** Pry	P No.	Target Date	Description	Sub by:	Owner:	Assigned to:	Dated Logged	Last Update	Comments
25	Ordinance	O	M	21	TBD	Review current ordinance governing stormwater drainage measurements to determine if updates are needed. Create stormwater performance standards for future development in Village and/or for businesses wishing to access Town's stormwater system.	Doug Webster	Deb Cabana	Doug Webster	03/06/18	02/04/20	During the CZA process with Cumberland Farms, much discussion was centered around "peak flow" vs. "volume" of stormwater drainage & about possibly updating the existing ordinance to cover both measurements. TC discussed and need Staff direction on item, as well as priority/timeline. Doug Webster made presentation (3/6) of feedback from Town Engineer. Recommendation is to memorialize Cumberland Farms discussions/approach to be used as a performance standard in conjunction with ordinance for future development. (2/5) Council discussed need to move this up to ensure work is done before MDOT comes to redo Main Str and to ensure used in future development proposals. (10/1) Dan advised OAC felt this one was easy to complete - moved up in priority. (2/4) Dan confirmed the OAC is back to meeting & has agreed to meet every other week to try to catch up. He advised they looked at Solar Overlay & Growth Cap and Duplex but need more guidance on the last. Priorities except for open space were unchanged. <b>Next Step: OAC to work on next.</b>
44	Ordinance	O	M	22	TBD	Review current residential Subdivision Ordinance for necessary changes all other areas (besides Open Space - see item 70)	Doug Webster	Deb Cabana	Doug Webster	02/05/19	02/04/20	(2/5) Doug advised there were some critical issues that needed review within the current residential Subdivision ordinance.(3/5) OAC provided priority order of outstanding items & this was included. Also, identified "Fire Protection" adjustments and Open Space standards as items to be worked on. (7/2) OAC set for 7/10 & this is on agenda. (2/4) Council agreed to split out Open Space (see item 70) to make a higher priority from other changes needed in ordinance. <b>Next Step: OAC/Staff will provide suggested changes to Council.</b>
36	Administrative	O	M	23	TBD	Review the current process for "Planned Unit Development" commercial subdivision to determine if routing the review & approval of commercial uses on lots in a PUD subdivision to the Staff Review Committee in lieu of the Planning Board.	Kathy Tombarrelli	Deb Cabana	Doug Webster	09/04/18	01/22/18	This item was brought up & discussed in the TC 8/7/18 meeting. Town Councilors agreed to consider the proposal, but could not determine whether support would be granted until some draft language was provided. Councilors expressed various concerns about the process which they would like addressed in that language. The Planning Board has also expressed some concerns with the change given PUDs are relatively new. (1/22) Dan advised Planning had is okay with change as Planning Bd Chair sits on Staff Review Committee <b>Next Step: Town Staff to draft language.</b>
67	Residential	O	L	1	06/01/21	To review the status Deer Acres property (private road)	Residents	Council	Council	12/03/19	10/06/20	(11/12) A group of residents gave a presentation to the Council regarding the current state of their private road - Deer Acres. The road is not actually a deeded private road, but private property with easements. The residents feel the road has been severely impacted by the status of Gore Rd, and the fact that it is used as a connector between Gore Rd and Lyons Point Rd. They are seeking a workshop with the Council to discuss further and develop possible options for solutions. (12/3) The Council expressed serious concerns with taking over a private road, but felt there could be other solutions and they needed more information. They agree to a workshop. (12/17) Bruce advised residents will not be ready to talk until at least April when seasonal residents arrive back in State. (10/6) Council recognized that the residents may be leaving for their winter homes and will push this forward until next spring. <b>Next Step: Bruce will let the residents know.</b>
81	Ordinance	O	L	2	TBD	Need to create a Water Extraction Ordinance	Sandy Carder	Deb Cabana	TBD	07/21/20	07/21/20	(7/21) Council was approached by Crystal Lake residents regarding many commercial vehicles from out of Town companies parking vehicles on the public boat ramp for long periods of time to extract water (pool, landscaping companies). Council discussed safety, access and water quality issues and agreed the activity should be prohibited. Deb spoke to the State and they advised we can put up signs right away - ordered. An ordinance should be created to ensure enforcement can be done properly. <b>Next Step: OAC to work time permitting.</b>

		*Status: O = Open C = Closed F= Future			Priority: **H = 1-3 months M = 4-9 months L = 10+ months - <a href="#">Guideline</a>			Last Update: 01/05/21				
No	Goal/Category	*O/ F/C	** Pty	P No.	Target Date	Description	Sub by:	Owner:	Assigned to:	Dated Logged	Last Update	Comments
39a	Administrative	O	L	3	06/01/21	Need to review//renegotiate <b>Cable TV Contract</b> sometime in 2019-2021.	Deb Cabana	Deb Cabana	Deb Cabana	09/18/18	09/15/20	Deb advised she has asked Alissa Tibbets, Town Attorney, to begin some research & that process can take up to 1 year. She also advised there is at least one resident willing to serve on a Cable TV Committee, if the Council choses to go that route. Council discussed briefly and confirmed either route will require legal review. Dan asked if there was a way for Alissa to provide a synopsis of the process/issues for council to better understand task. Deb advised significant changes have been made at the Federal level which will require more analysis before approach can be determined. (1/8 & 1/22) Feedback presented on item 42 Cable TV ordinance actually fit into the "contract" between parties. Will keep in mind for this item. (6/4) Legislature passed bill to roll back some of the changes (such as channel location, HD broadcast requirement, etc.) Deb advised GPCOG has sent out an RFP for the negotiator for the Towns involved. There was no interest in a pre-contract meeting. (8/6) Deb advised GPCOG is preparing contract with law firm (only one rec'd but highly qualified). (10/15) Deb/Brad provided updates from the negotiation meeting with GPCOG attorney. (1/7) Council agreed to separate contract and committee into two action items. (9/15) Audit by consultant resulted in identifying monies owed (\$18K+) to Gray. GPCOG est negotiations will begin in the fall. <b>Next Step: Randy/Brad to continue to work with GPCOG hired firm with regards to the negotiations.</b>

# H1-Comp Plan

*Status: O = Open C = Closed F = Future												
No	Goal/Category	*O/ F/C	** Pty	P No.	Target Date	Description	Sub by:	Owner:	Assigned to:	Dated Logged	Last Update	Comments
A	Comp Plan Imp - break out Item 84	O	H	3	02/08/21	Committee review of Comp Plan	Dan Maguire	Council	Council	12/01/20	12/01/20	(12/1) Dan suggested each Committee review CP to ID what would inform their work, how they can support implement, what roadblocks exist, what resources will be needed, etc. with a one page summary due by 2/8 for Council to review at 2/16 meeting. <b>Next Steps:</b> Council liaisons to bring to their assigned Committees.
B	Comp Plan Imp - break out Item 84	O	H	3	TBD	Consider New Committee to monitor, supervise, ensure Comp Plan implementation proceeds	Council	Council	Sandy Carder/ Deb Cabana	12/01/20	12/01/20	(12/1) Council agreed current Committee should be retired as their change is complete. Will send Thank You letters to Members and advise Council is considering a new Committee to assist with implementation - asking them to advise if they are interested in continuing on. New Committee needs further discussion. <b>Next Steps:</b> Sandy will update the Committee Policy to reflect retirement & work with Deb on letters.
C	Comp Plan Imp - break out Item 84	O	H	3	TBD	Department Heads review of Comp Plan	Anne Gass	Council	Council	12/01/20	12/01/20	(12/1) Anne suggested we either include Dept Heads on the Implementation Committee or at least ask them to review plan to create their own plans to help implement. Needs further discussion in context with new Committee. <b>Next Steps:</b> Set up workshop to discuss.
D	Comp Plan Imp - break out Item 84	O	H	3	TBD	Obtain information from Windham Town Council on their implementation plans	Sharon Young	Council	Sandy Carder	12/01/20	01/05/21	their newly approved plan and suggested we find out what steps they took to get from approved plan to where they are, how the Council is involved, etc. Sandy advised that the Windham Chair is on the GPCOG Executive Committee and she can reach out to him for information. (1/5) Sandy has sent a note to Jarod Maxfield 12/18. <b>Next Steps:</b> Sandy to follow up with Jarod.
E	Comp Plan Imp - break out Item 84	O	H	3	TBD	Create plan/timeline for Zoning changes & ordinance changes	Council	Council	Council	12/01/20	12/01/20	(12/1) Council needs to discuss/create a plan/timeline to update zoning to reflect zones in new plan and determine prioritization to ensure development adheres to new plan. Will be related to Item 46 (Growth Plan) and Item 49 (Duplex changes) for which initial discussions were held, but placed on hold pending Comp Plan approval. <b>Next Steps:</b> set up workshop to discuss.

Last Update: 01/05/2021

H3-TIF

*Status: O = Open C = Closed F = Future		Priority: **H = 1-3 months M = 4-9 months L = 10+ months			Target Date		Description		Sub By:	Owner:	Assigned to:	Dated Logged	Last Update	Comments
No	Goal/Category	*O/ F/C	** Pty	P No.	Target Date									
A	TIF Goal / Budget - break out tasks from Item 34	O	H	2	03/01/20	TIF - Mixed Use Zoning Discussion		Town Council	Town Council	Doug Webster		01/22/18	02/19/19	(11/28) Mixed Use options were discussed at length. Next workshop set for 2/19 6-7pm prior to scheduled TC Meeting. (2/19) Council discussed options and agreed having some type of proposed changes to consider would be helpful. Should focus on Village, but also on large undeveloped piece abutting Northbrook as owners req. inclusion to help develop. Doug will work on.
B	TIF Goal / Budget - break out tasks from Item 34	O	H	2	06/01/20	TIF - Shaker Rd Catch Basin/Sidewalk/Signage		Town Council	Deb Cabana	Town Council		02/22/18	01/05/21	Disc rt25 overlay proj, stormwater, sidewalks-would like to delay/coord all 3 into 1 proj. Steve/Will pres results of video work. Council agreed proj should not move forward, needs to be full replace. Report was rev with MDOT Dale Doughty, Kyle Hall, Deb & the Council (5/15/15) Steve pointed out full width paving was planned for some of Rt 26. Dale confirm catch basin upgrades will be done for those in that area. Sched a walkthru/meet w MDOT/Staff to rev of Rt 26 Vill to (1) Id what is incl in the upcoming overlay (2) dev a plan for the rest of the proj. Sub items: (a) G+P to prov key to their-fair, poor, good categ (b) Town to prov plans for swalks/sign. Based on MTA feedback reg bridge swalk/bike lane feedback-look at mak sure plans (if not fund/prior) immed) at least incl an ext of ped/bike lane down Skr to Str Bridge. It is the route to the M/HS from the Village. Results to be rev for budgetary imp by Council/Staff to create a partner agree plan. Overlay paving proj complete (1) slide to side to Wilson Funeral (2) reset catch basin in that area (3) travel lane only from there to bridge-sealant in break lanes. Steve pres PW rev at 9/10 TIF Wksp incl this item. Council swalk more infor on Main St proj for next steps. (11/28) Council disc possibly add sidewalk from Russell to Shaker Rd into eng of this proj and/or work with MSAD15 for poss trail thru their proj to sidewalk. May qualfor MDOT sidewalk fund. Eng for proj in budget. CIP-Council to disc 2/11. (2/19) Council agreed this is the top pri for fund. (6/11) Residents app budget+engn underway. (9/17) Will prov an update on engn, issues & Council prov feedback. (10/15) Will/Steve met with DOT will update council at 10/28 workshop. (10/28) Upd prov-Council agreed to submit MPI appl. (11/12) Council disc Gray Park sidewalk ait & agreed due to cost, it is not feasible. MPI should incl sidewalk on Gray Park Ericson side. Resol for park spaces imper. (2/4) Council held exe session-no act taken. (3/10) MPI app by MDOT. (4/21) Council has agreed to use \$100K from TIF + \$652K from Bond - ques to be put to residents. Public forum to be held on actual project once feasible (covid-19). (4/28) rev warrant art (6/2) Council app warrant art - go before voters 7/14/20. (7/21) Voters approved fund. Council to set up public forums. (9/1) Council set 9/29 for Public Forum - virtual meeting. Pre-planning meeting will need to be set up. (10/6) Sandy prov update from Public Forum. Alec/Will working on next steps. (11/17) Alec/Will will provide update 12/1 (12/1) Update prov - timeline appr - outstanding items ident - advertise by 12/11. <u>12/5 OUT to bid.</u>
C	TIF Goal / Budget - break out tasks from Item 34	O	H	2	TBD	TIF - Analyze future needs for Village Main Street to coordinate with MDOT project		Town Council	Town Council	Town Council		02/19/19	09/01/20	MDOT has agreed to cover the upgrade of the stormwater system and catch basins located along Main Street in the Village and down 202 towards the Cemetery. They advised the plan will likely come up in the next 5-7 years. Town needs to identify any other changes - such as - Increasing water line size, Increasing stormwater line size, adding conduit for underground utilities, adding piping for natural gas - so that funding can be budgetted and all items addressed at the same time (rip the road up once - saves money). (4/2) Doug provided 8-12 year windrow for work on Main Street as guide for Council - meaning analysis & planning should be done well beforehand. (4/16) MDOT advised the timeline for this project is being moved up. Council agreed to move up in priority at 5/7 meeting & set a stand alone TIF workshop - likely in June. Workshop held 7/2. (8/6) Minutes from 7/2 workshop approved. Council to set up another TIF workshop. (9/17) Sandy advised Stephanie Carver at GPCOG would like to see our minutes and join us for future brainstorming sessions - all infrastructure projects as a way to better understand Gray issues. (7/21) Council had workshop with MDOT & learned portion of road may be worked on in separate project for which engineering is underway. Awaiting more info from MDOT. (9/1) Village walkabout was done with Patrick Adams MDOT, Water District, and others to identify issues/solutions. Rob Betz is coordinating with Ernie Harris on current project from Town line to Cumby's. Council followed up to determine scope of 2nd project from MTA interchange to Brown Street? Can orphan piece be added to that project?

\*Status: O = Open C = Closed F= Future  
 Priority: \*\*H = 1-3 months M = 4-9 months L = 10+ months

Last Update: 01/05/2021

No	Goal/Category	*O/ F/C	** Pty	P No.	Target Date	Description	Sub By:	Owner:	Assigned to:	Dated Logged	Last Update	Comments
D	TIF Goal / Budget - break out tasks from Item 34	O	H	2	TBD	TIF - Center Rd / Bridge Redesign	Town Council	Town Council	Town Council	02/18/18	02/19/19	Town to evaluate possible changes to bridge and/or reconfiguration and/or completion of Turnpike Acres - to address Center Rd outlet just below 5 Rd intersection/left turn issues for tractor trailers in Village (possibly part of TIF workshop to determine plans/priorities for Village infrastructure upgrades). MTA advised that Bridge was recently refurbished & widened so there are no immediate plans for more work; however, they remain open to discussion a realignment. (12/4) Part of solution to address tractor trailers in the Village is to address inability to make right hand turn from 202 onto route 100 - which includes alternate route - maybe via turnpike acres/center rd bridge. (2/5) IC moving to TIF Planning umbrella (2/19) Deb to find out replacement year from MTA.
E	TIF Goal / Budget - break out tasks from Item 34	O	H	2	TBD	TIF - Rt 100/115/202 Intersection - related to Item 4 - Traffic - Low priority - Route 115 entering Gray from the hill thru connection to Brown Street	Town Council	Town Council	Town Council	02/05/19	10/15/19	Steve L is working on creating a project scope & plan for reconstruction of Route 115 leading into the Village with Will Haskell to submit to MDOT - in hopes of qualifying for 50/50 funding split (up to \$500,000). Council needs to develop options for the multi-road intersection in the Village to ensure whatever future configuration needs are considered in the Rt 115 project and the Rt 115 project helps facilitate the preferred future configuration. (2/19) Deb to find out if Haskell is working on any planning to prepare for proposal to MDOT - is engineering covered or will it need to be paid for - up front (10/15) Will/Steve have more info from DOT & will update Council at 10/28 workshop.
F	TIF Goal / Budget - break out tasks from Item 34	O	H	2	TBD	TIF - Evaluation of possible Sewer/Water treatment option for Village	Town Council	Town Council	Town Council	02/05/19	02/19/19	During TIF public forums, a specific piece of property (22 acres) was added to the map as it was considered a good candidate for a future water treatment / sewer facility - due to the soils and location (gravity my eliminate need for pumps). (2/19) Deb confirmed TIF funding can be used to purchase property; however, it can only be done once a full blown plan is created for usage. TIF funds cannot be used to buy property for recreation purposes. Council to discuss land acquisition C/P at 2/21 budget meeting. Council has agreed to set up a separate question on the warrant articles & will approve those articles at 5/7 meeting.
7	TIF Goal / Budget - break out tasks from Item 34	O	H	2	TBD	Develop possible Special Assessment Fees - handling as part of TIF discussions	Town Council	Deb Cabana	Town Council	01/22/18	02/05/19	The Planning staff provided high level information regarding possible use of a developed Special Assessment Fees which would be collected as part of new development to offset various costs. Council agreed they should be added to the tool box and requested more detailed information be pulled together for consideration. May be handled in conjunction with In Lieu Fees. 9/18 Council discussed reauthorizing, but decided to leave as is. Dan suggested that we identify other Towns using these fees and use their language as a base. (2/5) Council agreed to handle as part of TIF planning. Next Step: Determine when Staff has capacity to work on.
8	TIF Goal / Budget - break out tasks from Item 34	O	H	2	TBD	Develop possible In Lieu Fees - handling as part of TIF discussions	Town Council	Deb Cabana	Town Council	01/22/18	02/05/19	The Planning staff provided high level information regarding possible use of a developed In Lieu Fees which would be collected as part of new development to offset various costs. Council agreed they should be added to the tool box and requested more detailed information be pulled together for consideration. May be handled in conjunction with Special Assessment Fees. (2/5) Council agreed to handle as part of TIF planning. Next Step: Determine when Staff has capacity to work on.

**M1-1 MDOT & M1-2 MTA**

*Status: O = Open C = Closed F = Future		Priority: **H = 1-3 months M = 4-9 months L = 10+ months		Last Update: 01/05/2021								
No	Goal/Category	*O/ F/C	** Pty	P No.	Target Date	Description	Sub By:	Owner:	Assigned to:	Dated Logged	Last Update	Comments
A	Traffic - MDOT - break out tasks from Item 24A	O	M	1.1	06/01/21	Signage - Route 26 vs. Route 26A	Town Council	Deb Cabana	Deb Cabana	02/22/18	01/05/21	Village diversion/misdirection. Looking into eliminating/renaming route 26/26A to prevent Trucker from going the wrong way through the village. MTA committed to helping push for changes with MDOT at last night's meeting & advised a suggestion to remove Route 26 starting at Washington Ave (Portland) through to merge with 26A has been suggested in the past. Route 26A would just become Route 26. Also, Jason suggested using the Town sign by the Transfer station or other electronic signs. Note: Cathy Green had offered to check in with Garmin to obtain more information on GPS algorithms/process - follow-up? MTA will be closing bridge in summer 2019 - good time to coordinate removing "route 26" designation from Washington Ave to bridge. Keeping it from interchange - by-pass - north only. Deb is sending more 9/4, (12/4) MTA pointed out MDOT is not in agreement with full closure of the bridge due to lack of ability for rigs to turnaround if they miss detour signs. Also, not committed to changing route signs at this time - more discussion to follow. (9/17) Sandy advised she mentioned this issue to Rep Moriarty and he advised he would be willing to look into it to determine next steps on a formal request. (10/15) Rep Moriarty has established communication with DOT legislative liaison and they are willing to set up a meeting with DOT Staff that handle routes. Council discussed having pre-meeting but feel Rep Austin & Sen Breen are up to speed - Sandy will advise Rep Moriarty. (11/12) Sandy advised a meeting is set. (12/3) Sandy reviewed results of meeting & weight limit options. MDOT to provide info on costs for signs to change designation for just in Gray. Council agreed to coordinate weight limit with sidewalk project meeting & attempt to obtain approval. (1/21) Sandy sent follow-up on sign count/costs and asked for more info on weight limit process. (2/4) Sandy adv MDOT adv they were looking into (3/10) Sandy will follow up (8/4) Follow up done MDOT still needs to discuss before getting back to us. Council to set up public forums in Sept. (9/1) Public Forum set 9/29 - Sandy to follow up again. (9/29) MDOT sent resp hours before public forum. (11/17) Sandy will draft resp to MDOT letter. (12/15) Council approved response letter to be sent with alternate proposal to remove 26 & add to 26a while 26a remains. Weight limit work will continue via communication with residents/businesses. <a href="#">1/5/ Letter sent.</a>
B	Traffic - MDOT - break out tasks from Item 24A	O	M	1.1	04/01/21	Signage/Bollard Posts - Village Island	Sandy Carder	Deb Cabana	MDOT	02/22/18	06/04/19	MDOT will look at what they can do to make the island at the 5 lane intersection stand out so vehicles do not go the wrong way into head on traffic. Only current sign is "ENTER" provided by MTA. New striping is planned, but no response otherwise (9/4). 9/18 Council asked Deb to follow up with MDOT on their review - she advised she has meeting with MDOT on Wed 10/10. (12/4) Sandy asked MDOT at meeting about options. MDOT said they may have some flexible bollard type posts to try - will check their inventory. Steve noted it does make plowing more difficult. MDOT also may look at new signage - but that will require a full re-engineering of electric/posts at the intersection - see r115 listing on task list; (4/2) Dan advised at seeing another person drive into head on traffic in the wrong lane around the village island. (4/16) Deb advised MDOT is not willing to spend on permanent bollard due to history of destruction & costs. (6/4) Deb confirmed striping cannot be done before 7/1 (budget). Sandy asked if "ENTER" could be added to striping - may not be visible. <a href="#">Awaiting alternatives from MDOT.</a>

\*Status: O = Open C = Closed F = Future  
 Priority: \*\*H = 1-3 months M = 4-9 months L = 10+ months

Last Update: 01/05/2021

No	Goal/Category	# of F/C	** Ptny	P No.	Target Date	Description	Sub By:	Owner:	Assigned to:	Dated Logged	Last Update	Comments
C	Traffic - MDOT - break out tasks from Item 24A	O	M	1.1	TBD	Village Route 100 Catch Basins	Town Council	Deb Cabana	Town Council	02/22/18	09/01/20	MDOT requested the Town proceed with video work to determine status and wants to be involved in that process. In follow-up meetings with MDOT, Council would like to ensure MDOT planning dept. is represented. Steve advised video work not complete as of 9/10 TIF Workshop, but should have more information to present at 10/16 TC meeting. (12/4) Will Haskell's report showed system is better than anticipated with (3) items needing immediate attention - rest in 5-10 year category or 10-15 year category. Dan asked if rest of stormwater system has been evaluated - it has not. (12/4) MDOT confirmed they will be responsible for the stormwater system when they reconstruct Main street & will address any critical issues in the meantime. Council needs to determine what other items they may want - large water pipes, conduit for underground utilities, larger stormwater capacity, etc. MDOT has advised they are moving this project up in their timeline. Council moved up in priorities at 5/7 meeting - with TIF workshop projected in June. Workshop held 7/1. (6/16) During workshop with MDOT, an overlap was identified between this future project and a "rehabilitation" project currently in the engineering phase with a target for the 2023 construction season. Rob Betz will reach out to project manager to obtain additional information as any work done on the rehab project would not be -redone or tore up- with this future project. Town wants ability to have input in all stormwater/sidewalk/etc. work from just North of Colley Hill through the large intersection and onto Route 202 towards MTA interchange. (8/4) Rob advised he will coordinate with Ernie but also that another piece is being pitched next cycle. Council agreed we need to be involved in both. Walk around set for 8/5. (9/1) Walk about held - Sandy follow up with Rob to determine scope of 2nd project - can we include 'orphan' piece.
A	Traffic - MTA - break out tasks for Item 24B	O	M	1.2	12/31/20	Diversion Study	Town Council	Deb Cabana	Deb Cabana	02/22/18	01/05/21	Town to work define goals-study/permits/data set to capture as much data/results as possible related to exist prior traffic issues. need to determine partners-NG, Poland, Cumberland, Auburn, Windham? MTA had proposal 80% of fund, but suggest Muni commit would provide more control over study/ensure buy-in. Partners could share the costs of the 15-20% of likely need, more data added to study = high costs. Deb advised MTA is work on proposals, costs and part comm. & hopes to present at Oct TC meet. (12/4) MTA press new data capture/purchase that will include data while drop costs. Scope discussed with Councilors need to send additional feedback to Deb-changes may increase costs-but MTA commit to a good study rather than just a 'cheap' one. MTA will reach out to NG next to determine if they will participate. (12/8) Deb will reach out to MTA to obtain new contract (Bruce Van Note has been appointed to head the MDOT). (12/5) Mr. Mills resp, but provide no name. (12/19) Mr. Mills is taking a draft approval from Mr. Van Note-he is proposing MTA buy subject at March meet. (3/5) NG is not interested in participating. (4/2) Sandy provide PPH article and MTA, MDOT, PACTS and Portland Transport group have agreed to provide software. Await additional feedback from Mr. Mills. Residents approved budget. Deb sent email to Mr. Mills. (9/3) Mr. Mills advised they are still working on it. (9/17) Sandy advised COG has access to data & sent material to Steph Carver as they were interested to see if there was a role for COG to play. (11/12) Steph advised COG can provide info-Sandy to ob more info. (12/3) Sandy provide update - GPCOG to take leave & provide proposal for full council to consider. (1/7) Sandy provides scope from COG-Council request for MTA buy-in, but mail agreed to move forward. Sandy will follow up with Steph. Council will vote on engagement letter at 1/21 meet. (1/21) Council voted to approve engagement letter. (2/4) Sandy recap committee call with COG-ok with changes will look into phase 2 study to capture 'avoidance' vs. 'diversion' traffic with MDOT funding? (3/10) Sandy will follow up - Steph Carver is leaving GPCOG. Sen. Ned Claxton ask for info as his constituents in NG view this as a top issue. Sandy shared. (5/19) Study due end of June. (7/21) Delay but COG will add 'avoidance' analysis at no charge - target is Sept (9/1) Sandy advise draft report is done - final report should be received in a couple weeks. (9/15) Sandy advise final report has been received - will send to Council & set up discussion when time allows. (10/6) WTA/MDOT have provide feedback to GPCOG. They respond to MTA, incorporating changes for MDOT. NG has ask for copy. Deb to talk to NG Mgr. (11/17) GPCOG respond to MDOT & start work on updating. (12/15) Sandy has received updated study - will pull together all the material & send to Council. Will be placed on a future workshop agenda. (1/5) Diversion info shared - available WS

*Status: O = Open C = Closed F = Future		Priority: **H = 1-3 months M = 4-9 months L = 10+ months			Last Update: 01/05/2021							
No	Goal/Category	*O/ F/C	** Pty	P No.	Target Date	Description	Sub By:	Owner:	Assigned to:	Dated Logged	Last Update	Comments
B	Traffic - MTA - break out tasks for Item 24B	O	M	1,2	06/01/21	MTA Data - cash collection (vs EZPASS)	Town Council	Sandy Carder	Sandy Carder	02/22/18	03/10/20	MTA will prov data for cash (vs EZPASS) from the regl booths-Gray,NG,Falm - to better deter funds being collect by high tolls. Ident collect funds will prov base to deter alter in toll location prices. Toll Data was prov, but Sandy asked if classes could be split out (12/4) Some minor toll disc occur at meet with MTA confir they can prov addtl info. (2/19) Council disc opts for toll chgs and agreed to send letter to MTA with recom/feedback. (4/16) Sandy prov draft to Council. Dan prov feed to Sandy. Council prov feed to finalize letter in 5/7 meet & appr letter at 5/21 meet. Deb has sent. (8/6) Deb to follow up. Council agreed needed to follow-up before pull in Repres and/or Governor's office. (9/3) Mr. Mills resp as he has in the past. (9/17) Sandy met with Rep Moriarity & he agreed next step is a letter to Rep/Breen and Governor and perhaps they can meet to see what add pressure they can apply and the issue of Complete street policy. (10/15) Sandy proposed alter approach of asking Leg. Reps to submit the issue to the Governor's Blue Ribbon Commis for consid as several fund pieces related to both toll inequity and diversion. Dan pointed out use of 295 (or 95 north of Augusta) by commut vs those forced to use 95 (south) is an issue as well. Council agreed and also want to focus on ask Leg. Reps to consider a bill that would put more teeth in the MTA complete street policy and give muni more say. Sandy will draft for Council rev at 11/12 meet. (11/12) Letter rev with feed prov. Sharon expressed concerns with tone of letter. Maj of Council felt it needed to be strongly worded esp given news story where Mr. Mills was dismissive of issues. Sandy remind that it is to the legis team, not the MTA directly. Sandy to update and send. (12/3) Council approved letter. (2/4) Sandy adv committee contin work - follow up after session (2/18) Sandy prov update on status of comm and council agreed we should follow up now. (3/10) Sandy shared with Sen. Ned Claxton upon request

# FUTURE

\*Status: O = Open C = Closed F = Future  
 Priority: \*\*H = 1-3 months M = 4-9 months L = 10+ months

Last Update: 12/01/20

No	Goal/Category	*O/ F/C	** Pty	P No.	Target Date	Description	Sub By:	Owner:	Assigned to:	Dated Logged	Last Update	Comments
10	Administrative	F				Develop process to review status of Paper Streets	Town Council	N/A	N/A	01/22/18	01/16/18	During the Council discussion related to approving an extension to ROW access to paper streets, the Council inquired if there was a long term goal to create a process to review/identify streets which should be removed from the list. Resources/fining were discussed as hindrances. Council set this activity to "Future" given the renewal timeframe of 20 years has been reset. Future items will be reviewed annually, at a minimum.
21	Administrative	F				Develop a method to analyze & potentially rank Committee Volunteer applications when more than one received for one spot.	Dan Maguire	N/A	N/A	02/09/18		During a workshop discussion on Jan. 8th, the Council agreed there could be situations where a formal review/ranking system may be appropriate, but it is unlikely one needs to be used in most situations. The Council reviewed a variety of options, ideas, etc., but decided to table this issue for a later date. Will be considered a future item.
31	Ordinance	F				Review the issues and options surrounding Dock Lighting / Light pollution.	Deb Cabana	N/A	N/A	04/17/18	06/05/18	Town Staff has received a complaint/inquiry surrounding light pollution issues related to new LED dock lighting equipment. Given Councilor Fashay was absent at the Apr. 17th meeting, Council agreed to log (as it will be covered regardless - in closed, future or open) but to hold off discussion & prioritization until May 1st meeting review. Council discussed at June 5th meeting agreeing this would be considered a future item based on lack of available information. Possible OAC research item.
17	Economic Development / Budget	F				Research and compile data and options for a possible Community Center in Gray.	Town Council	N/A	N/A	01/22/18	05/07/19	During a Sept. TC Workshop discussing goals, the Recreation Dept. provided a proposal to realign funds collected by the Rec. programs under the Rec. Dept for use in maintaining/expanding programs. One major challenge identified was the lack of space to expand programs which create revenue streams for the Town. A new space (Community Center) was identified as a possible solution which could be paid for with current revenue streams. TC expressed support to obtain more information. Next Step: Rec. Dept. Staff will begin work to outline plan to obtain additional information. Council agreed this will be considered a "closed" Council item until the Rec. Dept. brings forth additional information. With availability of some land around the by-pass, this was discussed in 9/4 TC meeting. Deb stated \$62,000 is in the current fund. (11/13) Council agreed to move to Future list as the item continues to come up in discussions. (5/7) Concerns regarding current status vs. best practices were discussed during the 4/16 meeting - confirming programs exceed capacity at the Town facilities. See Closed Item #57. Manager advised it was Administrative and under her purview, council agreed to add to this item & close #57 with Manager bringing forward any necessary policy issues.
23	Ordinance	F				Review current ordinance governing noise for updates and research possible odor ordinance.	Town Council	Deb Cabana	Doug Webster	02/09/18	10/01/19	During the special amusement license renewal of the American Legion Hall, much discussion was centered around the current decibel restrictions for noise in the existing ordinance was set at a reasonable level, existing activities that may be above that level, how the level would be measured (by whom), and how complaints/enforcement would be handled. Doug Webster made presentation (3/6) of review/recommendations from Town Staff - raise limit to 60. TC discussed pros & cons of setting an actual decibel limit & enforcement. TC agreed to raise to 60, but also to add specific types of businesses/activities that would trigger limit. The Mfg Overlay/BD1/BD2 already have some type of noise restriction. Need to determine how complaints would be handled. (2/19) Council agreed to add "odor" to this item. (10/1) OAC feels due to lack of technology, other priorities and inability to enforce, this item should be moved to the future list. Council agreed.
80	Ordinance	F				To create rules for Chickens in the various zones in Gray	Anne Gass	TBD		07/21/20		(7/21) A couple issues have arisen regarding Chickens and understanding what is and is not allowed. No real defined information in Town ordinances. Should be addressed at some point.
83	Infrastructure	F				Identify Otisco Poles to be removed on short Shaker Road	Alec Dodd	TBD		12/01/20		(12/1) As part of the pole analysis done for the short Shaker Rd 2021 Spring stormwater/sidewalk project, Alec talked to Otisco. Several poles only support old copper wire services. Once all users are transitioned to Fiber services, those poles can be removed altogether.

CLOSED

\*Status: O = Open C = Closed F = Future \*\*H = 1-3 months M = 4-9 months L = 10+ months

Last Update: 12/01/20

No	Goal/Category	*O/ F/C	** Pty.	P No.	Target Date	Description	Sub By:	Owner:	Assigned to:	Dated Logged	Last Update	Comments
13	Ordinance	C	H	3	04/22/18	Town Staff has identified the need to add recreational marijuana specific language to the Shoreland Zoning ordinance.	-	Deb Cabana	-	01/22/18	09/20/18	Town staff identified a gap in ordinance coverage for the recreational marijuana ordinance language caused by the fact that Shoreland Zoning supercedes all other Ordinance language. Adding the recreational marijuana specific language will be required to ensure consistency across all zoning ordinances. Legal has confirmed this interpretation. Town staff developed & obtained legal review of proposed ordinance change. 1st reading 3/6 TC meeting. 2nd reading & Council approval provided 3/20 TC meeting. <b>Next Step:</b> Staff will update website to reflect approved changes. This item is now CLOSED.
9	TIF Goal / Budget	C	H	1	09/01/18	Consider the creation of a new Village TIF	-	Deb Cabana	-	01/22/18	08/07/18	The State Legislation is considering modifying the rules/requirements for setting up TIFs with a possible effective date in 2018. Given the changes would restrict the ability to set up new TIFs, the Council has agreed to begin the process of looking at the possibility of a new Village TIF to assist with upcoming infrastructure costs. Deb has provided Council with a TIF timeline and is working with the Town's Attorney & Staff to provide the necessary information to the Council for consideration. Council workshop (1/25), property owner workshop (1/31) & 1st public hearing (2/6) were held. TIF approved during special town meeting (2/14). TIF application submitted & received by State - approval can take 6-8 weeks. Feedback from state identifying 6 areas of concern was rec'd. Town Attorney responded on 4/11/18. State approved 5/23/18. <b>Next Step:</b> It is now closed as TIF is approved & in place. A separate "planning" task will be created.
12E	Ordinance	C	M	3.2	11/09/18	Review status of Road Associations for all Private Roads in Gray. A review of the current Street Ordinance identified a possible issue related to driveways with applying the ordinance to public driveways vs. private driveways.	-	Deb Cabana	-	03/20/18	09/04/18	Councilor Maguire brought this issue to the Jan 2nd. TC meeting where a review of the current ordinance, as well as additional information was completed. Town staff pointed out the issue is current one of 'authority'. It was agreed a legal opinion was needed before proceeding. Deb Cabana obtained & shared a legal opinion on Jan 16th. After further discussion (2/6), Council agreed a review of all private roads & the status of road associations. Council is breaking into 2 pieces. This listing will cover process to create plan to clean up contacts for private roads/discussions with road associations. Deb advised 1,000 letters have been prepared to send to private road residents - Council agreed (1) those w/o associations need to form one or provide ONE contact (2) All need to update contact information (3) reminder of road maintenance deadline to continue snow service (4) advise new contractor may be used. Letters sent 6/28/18. <b>Next Step:</b> Deb advised at 9/4 meeting they have received updated information from every private road except Cobbs Drive; therefore, this item is now closed.
32	Administrative	C	H	2	11/09/18	Review the current Contract Zone Agreement procedures to determine if changes or updates are warranted to make process better and/or to protect Town's interests more fully.	-	Deb Cabana	-	05/01/18	09/18/18	Council identified several major areas of concern during recent CZA review of proposed development. Council agreed to look at two specific areas (1) Financial stability (a) by identifying ways to verify developer has ability to meet financial obligations (b) creating language to allow Town to unwind agreement IF financial standing is compromised (c) ensure that benefits due to Town are frontloaded in agreement and (2) Environmental impacts are fully identified upfront during Council first review to ensure impacts are mitigated using various options. (5/1) Councilor Wilson has agreed to draft some language & review/discuss with Town Staff. In 8/7 meeting, Councilor Wilson advised he does not feel he is in a position to draft language. Councilors agreed that Town Staff needs to take a stab at adding the 2 new steps and also priority should be moved to High. Doug presented updated policy 9/18. <b>Next Steps:</b> Council approved updated CZA policy as presented at 9/18 meeting. Final version has been posted.

\*Status: O = Open C = Closed F = Future Priority: \*\*H = 1-3 months M = 4-9 months L = 10+ months

Last Update: 12/01/20

No	Goal/Category	*O/ F/C	** Pty/	P No.	Target Date	Description	Sub By:	Owner:	Assigned to:	Dated Logged	Last Update	Comments
D	Traffic - MTA	O	M	2.2	10/01/18	Forest Lake Ramp	-	Deb Cabana	-	02/22/18	10/02/18	MTA to share landscape plans for Forest Lake access ramp - once completed. Not discussed, does Weymouth access ramp have similar issues? MTA provided additional information with residents at a meeting. Item is considered closed.
20	Administrative	C	M	12	10/16/18	Develop a description for 'affiliated' committees which are not under the umbrella of the Town Council to help define roles/responsibilities. Ensure all Committees are following the specified Committee rules. Add'l ideas to discuss: Employee of Year, Scholarship Committee to oversee all scholarships, Comprehensive Plan Committee creation	-	Dan Maguire	-	02/09/18	10/16/18	After a workshop discussion on Jan 8th, the Council agreed to develop a description for affiliated committees operating in Town which are not under the Town Council umbrella. The description will then be posted to the website under Committees along with links for each of the individual committees. The Council also identified procedures that all committees should be following such as, submitting agendas 7 days in advance of meetings; posting meeting/agendas, creating minutes (with attendees, date/time/location, summary & votes), etc. OAC was not in compliance. Council is adding review of "email" policy for committees to cover FOA, but also manage costs. Dan Maguire volunteered to work on both items. Dan is working on & will circulate a draft to TC. Dan provided draft document to Council for consideration. Draft submitted to Council on 5/1. Council provided feedback on Dan's draft at the 5/15 meeting. New draft submitted to Council on 8/7. Due to time constraints, not discussed 8/7. Council agreed to final changes at 9/10 Workshop 10/2 - Dan needs more time & info from Sharon <b>Next Step:</b> Final changes reviewed & Approved by Council at 10/16/18 meeting. <b>Dan to provide 'clean-up' list to implement - this item is considered Closed.</b>
5	Ordinance	C	M	3	02/22/19	Review the issues and options surrounding a possible Fireworks Ordinance.	-	Deb Cabana	-	01/22/18	01/22/19	Residents have approached the Council with complaints and concerns regarding the lack of a Fireworks Ordinance. The Council discussed at several meetings and agreed to proceed with an analysis of the situation and options, potentially utilizing the OAC. Staff is working on possible options. Councilor Maguire advised the OAC will discuss in Mon. 3/26 meeting. Options were presented to & discussed by Council with feedback provided during 4/3 meeting. Staff presented ordinance at 1st public yearning on 5/1/18. Public feedback was rec'd, Council ques addressed, minor change made, Council voted to move forward with 2nd reading. 2nd reading set for 5/15/18. Ordinance was passed at 5/15 meeting & will go into in 30 days. 10/16 Councilors discussed one item brought up during public hearings - adding the Saturday before July 4th if July 4th lands on a weekday to tamper violations given this week is most celebrated fireworks weekend. Deb provided feedback from both law enforcement & fire chief that they saw a significant drop in complaints. Councilors also advised a noticeable drop in fireworks. Moved up priority list per Deb's request as changes fairly easy. (1/8) First reading of proposed changes held. (1/22) TC held 2nd read/public hearing & voted to approve. <b>Next Step:</b> Update to ordinance goes into effect in 30 days (2/22). Item is closed.
43	Ordinance	C	M	4	02/22/19	Need to create a Ambulance Service Fee ordinance.	-	Deb Cabana	-	10/16/18	01/22/19	Councilor Maguire inquired about the rescue billing process and it was determined a Public Safety Billing ordinance will be needed. Deb advised fairly easy to work up. (1/8) First reading of proposed ordinance held. (1/22) TC held 2nd read/public hearing & voted to approve. <b>Next Step:</b> New ordinance goes into effect in 30 days (2/22). Item is closed.

\*Status: O = Open C = Closed F = Future  
 Priority: \*\*H = 1-3 months M = 4-9 months L = 10+ months

Last Update: 12/01/20

No	Goal/Category	*O/ F/C	** Pty	P No.	Target Date	Description	Sub By:	Owner:	Assigned to:	Dated Logged	Last Update	Comments
12A	Ordinance	C	M	5	02/22/19	Review status of Road Associations for all Private Roads in Gray. A review of the current <b>Street Ordinance</b> identified a possible issue related to driveways with applying the ordinance to <b>public driveways vs. private driveways</b> .	-	Dan Maguire	-	01/22/18	01/22/19	Councilor Maguire brought this issue to the Jan 2nd, TC meeting where a review of the current ordinance, as well as additional information was completed. Town staff pointed out the issue is current one of "authority". It was agreed a legal opinion was needed before proceeding. Deb Cabana obtained & shared a legal opinion on Jan 16th. After further discussion (2/6), Council agreed a review of all private roads & the status of road associations. Council is breaking into 2 pieces. <b>This listing will cover discussion on ordinance/policy towards private roads/driveways.</b> Council agreed ordinance clarification is needed, but felt it must be part of the association clean-up effort (item 12B). Council agreed that clarification is needed in ordinance to require driveways comply regardless if on Private or Public road. Dan advised the OAC hopes to present language in October. 10/2 -Doug presented OAC changes but identified areas Staff disagreed. Council discussed (1) liked staff req on permits (2) need more info on apron. Voted down to allow further work & advised "council discussion" better place to start on agenda. (1/8) 1st Reading of proposed changes held. (1/10) Planning Bd held public hearing - no feedback. (1/22) TC held 2nd read/public hearing & voted to approve. <b>Next Step:</b> Updates to ordinance goes into effect in 30 days (2/22). This item is closed.
29	Administrative	C	M	14	12/31/18	<b>Planning board has requested some time with the Council to review policies/procedures between the two entities.</b>	-	Dan Maguire	-	04/03/18	01/22/19	Counciler Gallagher brought this to the Council & Council agreed to meeting. Lynn suggested we meet at a regularly scheduled Planning Board meeting. She will see if the May 10th meeting will have room. If not, we'll try June. Lynn discussed with Planning Board at April 12th meeting. They would like some agenda items submitted - June 14th is a tentative date - but may not work for PB. Council discussed options & agreed it would be best to have an agenda from Planning Board since they requested the meeting, also needs to be televised - could use handheld mic with table set up (joint leaders). 8/7 Dan advised PB working on agenda. Dan advised agenda will be finalized at 10/11 PB meeting & forwarded. 10/16 A finalized agenda was provided. Workshop was held on 10/25 & Council discussed at 11/13 meeting - agreeing PD should review & verify majority members support each item identified. (1/8) List provided to Kathy of Council items identified in joint meeting. Planning Bd discussed in December meeting. (1/22) Dan advised PD does not feel any additional action is needed at this time. Growth Cap was discussed and Town Staff will look into with OAC and bring forward when ready. <b>Next Step:</b> Planning Bd/TC to set up yearly joint meetings. This item is closed.
30	Budget	C	M	15	01/01/19	Set up <b>Debrief Budget Workshop</b> to (1) review budget process for possible changes (target dates, meeting dates, presentation) (2) review/update CIP plan beyond Bond (providing it passes) (3) review new projects/priorities with budget implications (4) TIF projects/planning	-	Deb Cabana / Council	-	04/03/18	01/22/19	Council would like workshop set up in early fall to cover budget issues (see description) before actual budget review/deadlines. This item will be a parking lot for specific items as well: (1) Succession planning - Town Mgr (2) TIF projects/priorities planning (3) Libby Hill conservation work (4) Watershed Plans (5) Wilkes Beach Project (6) Solar Array (7) LED conversion plan (8) Municipal property review results (9) Village sidewalk etc. to Wayne ave (10) Warrant article formats (11) Sidewalks No Raymond (12) diversion study (13) HR person inclusive. Workshop held on 10/18. Deb has created draft meeting schedule. Sandy created spreadsheet listing all budget related items discussed in the last year (or left over from last budget) (12/18) Workshop held - list reviewed & updated - draft calendar set with process defined. (1/22) Add'l meeting set for 2/11. <b>Next Step:</b> Schedule & approach set for 2019-2020. This item is closed.

* Status: O = Open C = Closed F = Future												
No	Goal/Category	**O/ #/C	** P/NY	P No.	Target Date	Description	Sub By:	Owner:	Assigned to:	Dated Logged	Last Update	Comments
Priority: **H = 1-3 months M = 4-9 months L = 10+ months												
42	Ordinance	C	L	1	02/22/19	Need to create an official <b>Cable TV Ordinance</b>	-	Deb Cabana	-	10/16/18	01/22/19	Deb provided notification that the Town will need to create a Cable TV Ordinance. Deb advised fairly straight forward, but Staff working on Marijuana, Fireworks and Public Safety Billing first. (1/8) 1st Reading held, Brad Fogg provided some feedback. Alissa advised most of those details will be part of actual contract, but a couple non substantive changes could be done prior to the 2nd reading (1/22) Non substantive changes were made. TC held 2nd read/public hearing & voted to approve. Next Step: Ordinance will go into effect in 30 days (2/22). This item is closed.
28	Administrative	C	L	8	03/01/19	Develop <b>fee for Code Enforcement online software.</b>	-	Deb Cabana	-	03/20/18	02/05/19	During the Budget discussions, TC approved an upgrade to new online Code Enforcement software which will make the process more efficient and reduce man hours needed to perform tasks. TC would like a fee created to cover the annual fee for the software which is \$18,000 in the first year. Staff updated several fees on schedule (approved by Council 6/19) to pass on some of the fees for new software. (1/22) Doug presented changes in Building Permit fees and a new Admin fee. Council had some concerns with Admin Fee. <b>Next Steps: Council approved new reduced "minimum" permit fee \$25 with new \$25 admin fee at 2/5/19 meeting. Item is closed.</b>
15	Joint Leaders	C	M	14.2	02/28/19	Review <b>MSAD15 current newsletter</b> - including costs & timing - to determine how/If Gray would like to collaborate and add material for distribution. NG will do the same.	-	Deb Cabana	-	01/22/18	02/19/19	During the first Joint Leaders meeting held on 11/27/17, the three groups identified expanding communication as one area of collaboration & benefit. Superintendent King suggested both Gray & NG consider partnering with MSAD15 by adding sections to their newsletter which is mailed to every household in GNGs. This would create another avenue to communicate directly with residents and sharing costs would be beneficial to all three groups. Deb advised that the Recreation Dept has had some preliminary conversations with MSAD15 and are working on pulling costs together. Deb checked to see if a combined budget mailing could be done, but the timing did not work out. Will try again next year. 10/2 - Dr King suggested a smaller group & offered HS library. Council had discussed pro/cons - agreed to format & req video. NG offered their location with video & agreed to format. Agenda pulled from last JL meetings provided. <b>Next Step: 10/29 meeting postponed - revisit in Dec.</b> Council agreed to close 14 - 15 - 16 as originated in 1st joint leaders meeting & log new item for new meeting.
16	Joint Leaders	C	M	14.3	02/28/19	Identify ways to <b>engage more students</b> in municipal government to increase interest in career paths, increase volunteerism & increase community building which would also help the Towns.	-	Dr. King	-	01/22/18	02/19/19	During the first Joint Leaders meeting held on 11/27/17, issues surrounding lack of candidates for job openings & volunteer spots on committees and in Town departments were identified as a major challenges for both Towns. MSAD also identified the need for students to obtain "life experiences" via volunteering or internships (locally) as part of their graduation requirements as a new challenge. Dr. King advised MSAD is currently reviewing their IB, Community Service Club and graduation requirements in this area and will be updating their approach. Council assigned Medium priority based on timeline - but no number as assigned to Dr. King. DMS Comm & Town Staff working with HS principal to see if students can assist with repair. Meeting was held on April 23 & tentative framework was set up for DMS collaboration. Jason to pursue setting up mock comp plan committee. 10/2 - Dr King suggested a smaller group & offered HS library. Council had discussed pro/cons - agreed to format & req video. NG offered their location with video & agreed to format. Agenda pulled from last JL meetings provided. (12/4) Joint workday project successfully completed on 11/1 between Excel Students, Town & Comm Endowment - via Carl, Sandy & Dean - with teachers Janet & Gail. <b>Next Steps: 10/29 meeting postponed - revisit in Dec.</b> Council agreed to close 14 - 15 - 16 as originated in 1st joint leaders meeting & log new item for new meeting.

Last Update: 12/01/20

\* Status: O = Open C = Closed F = Future Priority: \*\*H = 1-3 months M = 4-9 months L = 10+ months

Last Update: 12/07/20

No	Goal/Category	*O/ F/C	** Pty	P	Target Date	Description	Sub By:	Owner:	Assigned to:	Dated Logged	Last Update	Comments
35	Ordinance	C	M	16	02/22/19	Review the current <b>Medical Marijuana and Recreational Marijuana</b> (including shoreland) ordinances to incorporate changes created by latest legislation passed.	-	Deb Cabana	-	09/04/18	03/05/19	The Maine Legislation passed LD238 effective 7/9 and LD1539 which will go into effect 90 days after the legislative session - updating various areas related to both medical & recreational marijuana. Under advise from the Town's Attorney, Gray instituted a complete Emergency Marijuana Moratorium with readings in the July & August meetings. Once updates are confirmed, changes identified in the Gray Ordinance, the Council will proceed with a repeal & replace of the impacted existing Town Ordinances. 9/18 Deb provided update indicating Doug & Alissa were working on draft for 10/16 meeting. Councilors & Staff attended MMA summit on 10/4, Alissa & Doug provided overview of State legislative changes at 10/16 meeting & Councilors provided feedback on options. Council reviewed Doug's bullet points & provided guidance (11/13) (1/8) Alissa Tibberts reviewed proposed changes with Council in 1st reading. (1/10) Planning held public hearing - no feedback. (1/22) TC held 2nd read/public hearing - voted to approve & extended moratorium. (2/5) TC moved to Med priority pending last step. <b>Next Step: New ordinance goes into effect in 30 days (2/22). Council to vote to rescind moratorium at 3/5 meeting.</b> Council rescinded moratorium as new ordinances are now in effect. <b>Item closed.</b>
51	Ordinance	C	M	4	05/15/19	Tax Acquired Property Ordinance needs changes to incorporate State Level Legislative changes	-	Deb Cabana	-	03/05/19	04/02/19	Deb advised that the new State level changes adding steps to the disposal of tax acquired property for those residents 65 and older require new language in our ordinance. (3/19) 1st reading held - Sharon asked about a possible repeal of law. (4/2) Deb advised Alissa advised we proceed as repeal was put on hold for minimum of 1 year. <b>Next Step: 4/2 2nd reading held and ordinance changes approved by council to go into effect in 30 days. THIS ITEM IS CLOSED.</b>
41	Administrative	C	M	3	05/31/19	Review proposed 2018 changes to adopted Bike/Ped Plan - which will roll into Comprehensive Plan.	-	Town Council	-	09/18/18	05/21/19	Members of the Bike/Ped Committee presented an update on their work at the 9/18 TC Meeting and advised they have completed a review of the existing 2012 Bike/Ped Plan, conducted a Town wide survey and updated the language and identified their top 5 projects. The Council had previously discussed Public Works top priorities in the 9/10 TIF Workshop. It was agreed in order to approve the updates, a consensus on the top 5 projects should be reached. Part of that discussion should include MSAD15. 10/2 Sandy to request copy of document - Deb to make copies for Councilors. Dr. King sent feedback indicating MSAD interest in discussing sidewalks on Libby Hill and Gray Park. (12/4) Jason expressed concern with "TIF Funding" being listed as a possible funding source leading to improper use of TIF funds. Council to identify top infrastructure projects / budget priorities to better understand where bike/ped projects fall - 10/18 Budget workshop, 11/13 TC meeting, 11/28 TIF meeting & 12/18 budget meeting to provide more info. (1/22) See above item 40 comment - TC needs to update Bike/ped plan to have more leverage with MDOT & MTA on projects & as part of the Comprehensive plan. Council to finalize top 5 projects via budget discussions & then approve update (with changes if agreed upon). (5/7) Council discussed. <b>Next Step: Council approved updated plan at 5/21/19 meeting. This item is CLOSED.</b>
59	Ordinance	C	H	2	07/18/19	Review & update <b>Medicinal Marijuana standards</b> in new Ordinance to ensure original intent is not restricted and Gray remains in compliance with State statutes.	-	Town Council	-	06/04/19	06/04/19	(5/21) Doug made presentation to Council identifying conflicts and restrictions created with (1) length of set back and (2) way the set backs were being measured which unintentionally eliminated selected locations for Caregivers. Council provided feedback. (6/4) 1st reading of Doug's proposed ordinance changes to (2) way set backs are measured. Doug advised it may still be too restrictive and Council may need to revisit, but solves immediate issue with Caregiver. Council approved. Planning Board held public hearing on 6/13. <b>Next Step: 2nd reading &amp; public hearing to be held at 6/18 meeting. Council approved &amp; will go into effect on 07/18/19. This item is CLOSED.</b>

*Status: O = Open C = Closed F = Future												
Priority: **H = 1-3 months M = 4-9 months L = 10+ months												
No	Goal/Category	*O/ F/C	** Prty	P No.	Target Date	Description	Sub By:	Owner:	Assigned to:	Dated Logged	Last Update	Comments
2	Budget	C	M	5	06/30/19	Create a new <b>Facilities Use policy</b> to review fees, identify when fees will be waived, identify process for 'in kind' donations.	-	Deb Cabana	-	01/02/18	06/18/19	<p>During discussion prior to Fee Schedule approval, a question of whether or not local organizations incurring fee charges while working to raise funds to offset budget items should be exempt. Obtaining a legal opinion was suggested. Add'l situation has arisen with Rec Dept long standing agreement with "for profit" business to use volleyball court with reduced fee in exchange for work done by business (improvements/maintenance). Council agreed we need to (1) review fee structure for rec dept assets (2) need defined guidelines on when fees may be waived (3) need formal process to document agreements when fees are waived (4) identify CIP threshold for when donation can just be accepted vs need approval. Jason advised Committee will look at &amp; Dean set Sept as target date - but will provide periodic updates to Council to ensure everyone is on same page. 8/7 Councilor Wilson provided update during Comm Repts regarding impact fees. 9/4 Councilor Wilson advised committee still working on it. 10/2 - Committee could not hold meeting for final review (11/13) draft of policy did not address all 4 items. (2/5) Comm has discussed parameters to identify content (4/2) Jason advised Comm is close. Sharon brought up issue that vendor is currently await new procedure &amp; may need to cancel program if delayed further. (4/16) Policy changes discussed at meeting with feedback provided. (6/18) Council reviewed updated policy &amp; provided some add'l changes approved as amended. <b>Next Step: Deb &amp; Dean will finalize and publish and notify current users of change. This item is CLOSED.</b></p>
54	Administrative	C	H	5	07/02/19	Develop interlocal agreement with Raymond to address remaining section of Gore Road	-	Town Council	-	04/02/19	07/02/19	<p>(3/19) Deb provided background information regarding the remaining section of Gore Rd and current information on a proposed agreement between Raymond and Gray to repair/maintain that section of road. Gray would gift used lifts to Raymond, Raymond would use savings to put towards road repairs (along with funds from Rd Association &amp; Raymond residents). Raymond would assume plowing of 2 miles of private roads which cost Gray \$9,200 annually (increasing each year) in exchange for Gray plowing a section of N. Raymond Rd. Steve estimates that is a 50% less costly (\$4,600) annually. Over time, Gray would recoup lift funds and continue to realize savings beyond. Jason asked issues of legality - Deb advised both Gray &amp; Raymone attorneys are involved. (4/2) Dan has requested a formalized cost/benefit calculation to be made available when the agreement is presented to the Council. (4/16) Deb adv Raymond Board approved, Residents have deadline for petition signatures and funding obligations, and Raymond has set Town Meeting date. Bruce/Sharon also clarified their connections. (5/7) Council voted to move forward with both equipment gifting &amp; interlocal agreement (with secession wording added). (5/21) Sharon advised road assoc &amp; resident signatures/funds have been collected. (6/4) Raymond residents approved via Town meeting. (7/2) Final agreement approved by Raymond reviewed and approved by TC. <b>Next Steps: Agreement to be reviewed &amp; voted on at 7/2 TC meeting. This item is CLOSED.</b></p>

Last Update: 12/01/20

\*Status: O = Open C = Closed F = Future  
 Priority: \*\*H = 1-3 months M = 4-9 months L = 10+ months

Last Update: 12/01/20

No	Goal/Category	*O/ F/C	** Prty	P	Target Date	Description	Sub By:	Owner:	Assigned to:	Dated Logged	Last Update	Comments
	Comp. Plan Update - breakout of tasks for Item 11											Town Staff suggests a discussion regarding the Committee. Council agreed specific demographic profiles would be necessary to ensure a solid representation of as many viewpoints as possible. Doug to draft some suggestions. (9/18) Council agreed to hold off until after Heart & Soul presentation. (11/13) Council discussed & agreed that the immediate priority is setting up the Committee and Heart & Soul should not be pursued at this time. Dan also requested a timeline be created to assist with benchmarks & planning. Heart & Soul liaison has offered to assist us with Comp Plan Committee free of charge. (1/8) Doug provided write up of scope, characteristics, options to Council. Council provided feedback. (1/22) Council provide add'l direction on (1) application and (2) Change. (2/5) Doug's draft was reviewed with feedback provided. (2/19) Add'l changes discussed (3/5) Council approved docs. Town rec'd 10 applications. Council agreed to extend deadline to 5/16/19 to seek more. (6/4) Committee selected (9/3) Committee has held several meetings & elected a chair. <b>Next Step: This sub-task is considered CLOSED.</b>
26	Comp. Plan Update/ Conservation Plan											This task is dependent on the Comp. Plan green space inventory chapter. Awaiting inventory chapter for Comp. Plan. Prioritization will be done at that time. 10/16 Council discussed and agreed to prioritize as H2. (11/13) Due to M11 going back to Rec Comm, they will be unable to work this item. (1/8) Deb provided meeting minutes for a Staff meeting held on 12/20 with 2 land trust representatives & reps from local groups. (1/28) First public forum held with Alan Stearns & Lucky D'Ascario leading - notes taken & presented at 2/5 meeting. Sign up sheet of attendees to be provided. (1/28) Council discussed website options - Jolie to review & agreed additional meetings are needed. Dean meet with Alan & Lucky this week. (3/19) Dean provided update & next steps and Council approved moving forward. (7/2) Dean has been on vacation - Deb to follow up. (9/3) Council rev 3/19 approval of committee & Dean's assigned task to develop the Committee charge. <b>Next Step: Council approved Open Space charge, Committee size, approved Anne Gass as the liaison and appointed applicants. This task is considered CLOSED.</b>
47	Joint Leaders											This item replaces items #14, 15, 16 - which dealt with first joint leaders meeting held in 2017. Council identified (1) shared communication (2) Internships (3) sidewalk (4) solar array (5) budget - as items for discussion. (3/5) Bruce has sent a note to Dr. King. (6/4) Council agreed Solar Workshop would be likely next joint discussion. (7/2) MSAD set for Revision presentation in July. (8/6) Sandy attended MSAD15 Facilities meeting & reported back to full Council. (9/17) Sandy advised MSAD needs more time to contemplate their approach to solar. <b>Next Step: Council will await further contact from MSAD. This task is considered CLOSED.</b>
33	Ordinance											Karlene Hafemann, Community Health Promotion Specialist for Dept of Health & Human Services presented information to the Council at the 6/19/18 meeting. She advised the new signs could be provided free of charge if we update the ordinance to better enforce. Our ordinance is solid, but needs new forms of tobacco delivery included. MSAD15 has agreed to update their policies so good time to coordinate and also better in the summer months. Council agreed to proceed. (12/10) Karlene sent follow-up to Deb. Deb advised new (free) signs contingent on passed ordinance. Council agreed having in place before Spring advisable. (3/5) DAC provided priority order of outstanding items & this was included. (4/16) Sharon expressed concern with the delay on this item & pending Spring facilities use. (5/21) OAC discussed and found needed changes to boilerplate lang provided. (7/2) OAC set for 7/10 & this is on agenda. (8/6) Changes to be included in 9/3 meeting. (9/3) 1st reading held. (9/17) PB reviewed & held public forum 9/12. Council had 2nd reading & public forum 9/17. <b>Next Steps: Approved at 9/17 meeting - in effect in 30 days. This task is considered CLOSED.</b>

*Status: O = Open C = Closed F = Future												
Priority: **H = 1-3 months M = 4-9 months L = 10+ months												
No	Goal/Category	*O/ F/C	** Pty	P No.	Target Date	Description	Sub By:	Owner:	Assigned to:	Dated Logged	Last Update	Comments
45	Ordinance	C	M	7.1	09/30/19	Review 'multi-tenant' standard within <b>Sign Ordinance</b> for RRA Zone	Doug Webster	Town Council	Town Council	02/05/19	09/17/19	(2/5) State has approached Town regarding a waiver for a much larger sign for the Wildlife Park. Council is not willing to provide a singular waiver for State property and is cautious about changing ordinance outright as RRA covers a good portion of the Town. State is currently not willing to allow a "Dry Mills Schoolhouse" sign; however, if that sign was added and one for the R&W building, the sign would be considered a "multi-tenant" sign and new standards could be developed for that category. (3/5) OAC provided priority order of outstanding items & this was included: (3/19) Kurt from ME WP presented add'l info and advised adding DMS sign was acceptable. The cost of \$500 was identified. He also advised the lease will need to be updated which may be a good time for Town to extend term. (4/2) Sandy advised DMS committee has already raised funds for new signage. (5/21) OAC had prelin discussion at May meeting. (6/4) OAC provided feedback - back to Doug. (7/2) This discussion has been expanded to include other sign related issues - but will now be split out on the Tracking list. OAC/Planning Bd support tailored approach for this one sign. (8/6) Changes to be included in 9/3 meeting. (9/3) 1st reading held (9/17) PB reviewed & held public forum 9/12. Council had 2nd reading & public forum 9/17. Next Steps: Approved at 9/17 meeting - in effect in 30 days. This task is considered CLOSED.
48	Ordinance	C	M	6	11/15/19	Create a new Ordinance to <b>waive excise fees</b> for <b>active duty military personnel</b>	Sandy Carder	Deb Cabana	Deb Cabana	02/19/19	10/15/19	A resident has asked if the Town would consider this ordinance. State statute allows for waiver if active duty personnel are deployed for 180 days or more. Council agreed they would support an ordinance. (9/3) Sandy pointed out this change is dependent on specific state statute so OAC/Town planning dept probably not needed. (9/17) Deb advised the ordinance is very specific and Alyssa has reviewed. (10/1) TC held first reading & approved. (10/15) 2nd reading & public hearing held. Next Step: Council approved 10/15 - will go into effect 11/15. This item is CLOSED.
C	Traffic - MTA - break out tasks for Item 248	C	M	1.2	10/30/19	<b>Rt 26 (Shaker Rd) Bridge Resurfacing</b>	MTA	Deb Cabana	MTA	01/22/19	11/12/19	(1/22) Dan brought up the option to take a more aggressive approach with MTA to force them to provide Bike/Ped space on this bridge. Rep. Austin had rec'd a similar request from Brad Fogg and advised MTA is not reconstructing the bridge, but resurfacing it; thus, they cannot expand it. TC had been told this in our last meeting. The idea is to apply pressure and let them know how serious we are about accommodating our requests. It was pointed out that approving a Complete Street Policy (Item 40) and updating the existing Bike/Ped plan (Item 41) are in TC court & would give us more leverage; as would, funding the engineering for Rt 26 Village project to include sidewalks across the bridge. TC agreed those steps are important. Jason suggested requiring them to add State law 3 feet signs and Sandy suggested asking them to narrow the travel lanes from 12 feet to 10 feet to slow traffic & provide 4 add'l feet for Bike/Ped passage. (2/19) Council agreed to have Deb go to MDOT (1) state we want 10 foot striping instead of 11 foot (agreed on by MTA) and (2) check if there is a rule requiring breakdown lanes vs. raised sidewalk on bridges. (3/5) Mr. Mills advised they would approve a 10 foot lane, but there is an appeal process. Council agreed to pursue the appeal. (3/19) Town Staff & Engineer provided feedback on appeal process and likelihood of defeat. Council agreed to not pursue. (4/2) Council wants to confirm MDOT will stripe at 11 feet vs. 12 feet. (4/16) Deb obtained confirmation on 11 feet striping - project to begin this month. Project is underway. (10/15) Dan suggested req. side rumble strips - but due to cost and possible diff safety issues (cyclists), Council agreed to follow-up with DOT on agreed upon striping. Project is wrapping up but appears will go a couple more weeks. (11/12) This project is complete - item CLOSED

Last Update: 12/01/20

*Status: O = Open C = Closed F= Future												
Priority: **H = 1-3 months M = 4-9 months L = 10+ months												
No	Goal/Category	*O/ F/C	** Pty	P No.	Target Date	Description	Sub By:	Owner:	Assigned to:	Dated Logged	Last Update	Comments
64	Administrative	C	M	5	12/03/19	Complete annual review of Council Rules for updates.	Council	Council	Council	08/06/19	12/03/19	(8/6) Sandy requested any council rule proposals be submitted for consideration in at 8/6 meeting - discussion included for formatting changes, language clean-up, november meeting schedule, packet submission schedule (which was out of synch with chart being used) and new language around chair responsibilities and staff/legal time. Straw poll on formatting, now meet & submission timeline was held - 5-0 on all. Addtl' info was req on social media & staff/legal time language. (9/3) Vote & further discussion was set - but tabled as Anne was not at meeting. (10/1) Vote taken for repeal & replace to include 3 areas of changes passed. Addtl' discussion and straw poll on social media and addtl' VC chair language were held 5-0 support. Addtl' changes requested on staff/legal time language. (11/12) Council approved VC language and social media rules, and provided feedback on legal/staff time language. <b>Next Step: Anne to update &amp; submit to Deb/Sandy for 12/3 agenda vote. (12/3) Final vote taken - this item is CLOSED.</b>
53	Ordinance	C	H	8.1	04/01/20	Review existing Senior Tax Relief Programs to determine if a program will work for Gray - creating ordinance, forms & procedure.	Sharon Young	Town Council	Town Council	04/02/19	01/21/20	(3/19) Sharon presented a draft ordinance and program information to Council under Discussion item and requested a 1st reading be placed on 4/16 agenda. (4/2) Sandy advised she has discussions and requests for more information and asked if it would be better to handle as discussion item on 4/16 and 1st reading on 5/7. Sharon wants to proceed with 1st reading. (4/16) Sharon advised she would like to table to a workshop given it was not included in the budget. She also advised contacts in Cumberland would be willing to do a presentation before the Council. (6/4) Council rec'd presentation from Cumberland Councilor & discussed. (6/18) Council discussed possibility of using addtl' revenue from state, but majority did not support. Agreed to work on parameters/policy to consider in next budget cycle. (8/6) Workshop held with feedback provided. (9/3) Sharon provided demographic/program info from other towns. Anne sent some info on asset testing - Deb is working on pulling addtl' data as well. (10/1) Council discussed at workshop providing feedback on parameters. (11/12) Majority of Council came to consensus on parameters for program with Sharon updating document accordingly. Disagreement on next step. Majority want to hold off on official reading/votes until after budget cycle to ensure funding in the year is possible. Sharon insists on a vote in Dec meeting. (12/3) Council reviewed final language & provided some changes. (12/17) Council agreed to move one req change to ordinance to application. (1/7) Majority of council approved 1st reading. <b>Next Step: Public Forum &amp; 2nd reading set for 1/21 meeting. (1/21) Final vote taken - goes in effect in 30 days - this item is CLOSED.</b>
73	Administrative	C	H	7	04/01/20	Update Committee Policy to address quorum & residency requirements	Dan Maguire	Dan Maguire	Dan Maguire	02/18/20	03/10/20	(2/4) Council discussed various typographical changes needed to the policy as well as consistency in list/b information on the website. Agreed Dan could just work directly with Julie on those changes. Also, discussed issues being experienced in the area of quorums when many committees are not taking official votes all that often (and many have no finances). Agreed official meetings could be held without quorum, but any official votes would still need them. Also, Blueberry Festival Committee requested an exemption to allow non-Gray residents to volunteer for the Committee. Council agreed. <b>Next Step: Dan will add language to address the quorum and residency changes and submit to the Council for a vote. (3/10) Council approved changes - this item is CLOSED.</b>

Last Update: 12/01/20

\* Status: O = Open C = Closed F = Future \*\*H = 1-3 months M = 4-9 months L = 10+ months

Last Update: 12/07/20

No	Goal/Category	*O/ F/C	** Ptry	P No.	Target Date	Description	Sub By:	Owner:	Assigned to:	Dated Logged	Last Update	Comments
40	Administrative	C	M	5	03/15/20	Review a <b>Complete Streets Policy</b> & approve acceptable policy - which will roll into <b>Comprehensive Plan</b> .	Bike/Ped	Town Council	Town Council	09/18/18	04/21/20	Members of the Bike/Ped Committee presented an update on their work at the 9/18 TC Meeting and advised they have developed a Complete Street policy for Gray. They advised that the MDOT and several other communities have adopted complete street policies and Councilors discussed how it has come up when planning large road projects with MDOT/MTA. It has been submitted to Town Staff for review and feedback. Council discussed prioritization in content of whether part of comprehensive plan or stand alone item. Agreed to "medium" to start off. (1/22) TC discussed concerns with RT 26 bridge replacement which excludes bike/ped. One issue if Town needs to approve CSP before mandating MTA do the same. Would give us more leverage. (5/21) Council agreed to move up to M3 and to approach as a policy rather than ordinance changes. (8/6) Anne req this be added to an Oct agenda. (10/1) Council agreed to add to 11/12 workshop. (11/12) Council discussed and provide some initial feedback. (12/17) Anne & Dan to discuss 12/18. (1/7) Council reviewed and agreed next step is for Anne to present to the Planning Board for their feedback. (2/18) Anne reviewed with PB - they had some feedback but felt it was above their responsibilities as it was not translated into ordinances which is what they apply. (3/24) Anne has submitted to Deb. <b>Next Step: Deb sent to Alyssa for a review. (4/21) Council approved policy with 1 minor change - this item is CLOSED.</b>
39b	Administrative	C	L	2	07/01/20	Consider the formation of a <b>Cable TV Committee</b> .	Deb Cabana	Deb Cabana	Brad Fogg	09/18/18	04/21/20	Although the Council decided to join the GPCOG coalition to hire one law firm to represent all member Communities in the contract negotiations, the Council did agree to consider a long term Cable TV Committee. This item is pulled from item 39a. (6/18) A community meeting was held to determine if there is enough interest to form a committee to assist the Town with the TV station. (9/3) Deb advised Randy Visser will make presentation (9/17) Randy presented info to council. (10/1) Deb/Anne to work to clarify if Randy has volunteers for a committee. (11/12) Deb is reviewing proposed Comm charge & will have ready to present to Council at Dec meeting. (12/17) Council rev initial draft of committee charge with conversation with Brad. (3/10) Dan provided remanded charge to Brad. Brad/Randy to review & finalize. Sandy provided timeline to get on the 3/24 agenda. (3/24) Council approved the charge for the committee. <b>Next Step: Brad/Randy to submit volunteer applications for 4/21 meeting. (4/21) Council approved Randy Visser's application and will see Brad's at the 4/28 meeting. This item is CLOSED.</b>
A	Comp. Plan Update - breakout of tasks for Item 11	C	H	1	11/01/20	Inventory Chapters / map updates from GPCOG	Town Council	Deb Cabana	Northstar	03/06/18	06/02/20	Request for GPCOG estimate to provide inventory chapter updates which was provided via e-mail. Discussed in budget & 3/6 TC meeting. 1 mth/\$5,000 per chapter from GPCOG. 20K avail now - TC gave staff the green light. Doug Webster provided a GPCOG contract update/timeline for their chapters. 9/18 - (4) draft chapters have been provided by GPCOG & Doug is working on locating a Map for the recreation dept to begin identifying open spaces. (11/13) Doug advised all chapters have been received and are being reviewed by staff. GPCOG is still working on map. (1/8) Doug advised chapters are done & with staff for review. GPCOG is on target with projected timeline for map. (2/4) update provided to Council - Committee to work on review/update to inventory chapters. (4/21) Doug/Kathy advised Town Staff has reviewed and updated all but one chapter which should be done in the next week. <b>Next Step: Staff to finish, send to GPCOG to be incorporated in 1st draft of Plan. (6/2) CPSC has completed the first draft and submitted it to the State. The inventory chapters are considered closed - thus this item is CLOSED.</b>

\*Status: O = Open C = Closed F = Future Priority: \*\*H = 1-3 months M = 4-9 months L = 10+ months Last Update: 12/01/20

No	Goal/Category	*O/ F/C	** Prty	P No.	Target Date	Description	Sub By:	Owner:	Assigned to:	Dated Logged	Last Update	Comments
58	Ordinance	C	H	11	06/15/20	Review existing <b>Livelong Living Committee</b> to determine if a program will work for Gray - creating ordinance, forms & procedure.	Sharon Young	Town Council	Sharon Young	06/04/19	08/04/20	(6/4) Council rec'd presentation from Cumberland Councilor & discussed. Council agreed an "Aging in Place" Program is separate from the Senior Tax Relief Program and could be pursued independently. (6/18) Council discussed further and agreed to looking at next steps in a workshop. (8/6) Workshop held with agreement this needs to be an organic citizen effort - not Council or Town Staff. Gray's needs are likely different than other towns and it is unknown which services/programs would be most needed. (10/15) Sharon advised she will not work on until after tax relief program is finished - est Dec/Jan. (12/3) Sharon advised there are a couple residents will to start affiliate committee. Sharon had requested info from Sec. of State office on voter registrations which would require Council approval. She advised she re-submitted application & will keep Council apprised. (12/17) Sharon advised there may be a grant opportunity to help set up programs. Council agreed to review material. Also, advised more discussions are ongoing regarding pilot communities for programs. (1/7) Grant appl was not completed in time for inclusion in packet, but was presented with req to add to agenda. Council approved pending add'l changes which Anne was to submit to Sharon and upon condition that the Committee discussion occur at the 1/21 meeting. (1/21) Sharon advised she was not submitting 2/15 Grant. Council ran out of time so was pushed. (2/4) Council discuss pilot prog but due to staff req, grant app deadline being 2/15 & add'l budget impact - to decline. Another option will be presented at 2/18 meeting. (2/18) Council agreed 5/b an affiliate committee for now. (3/10) Grant for outreach was approved. Committee is finalizing survey with 4/1 target date. Unfortunately, the Shared Community Coordinator grant was not approved. (4/21) Survey is ready to be mailed. (4/28) Sharon adv survey has been mailed out. (5/5) Sharon adv they have rec'd quite a few back with some good results. She has also fielded some calls. (7/21) St. Joe's collage is tabulating results. <b>Next Step: Await survey responses - target is 3 weeks for the online survey availability.</b> (8/4) Council agreed there is no further work for them until Committee provides survey results and reqs ast formally. Budget placeholder will be logged. <b>This item is CLOSED</b>
68	Ordinance	C	H	5	10/15/20	Review proposed <b>Local Food Rules Ordinance</b> for implementation.	Local Food Rules Committee	Town Council	Anne Gass	12/17/19	09/15/20	(12/3) Local Food Rules Community Group presented their proposed ordinance and provided some first hand experiences currently happening in Gray. Provided information on how the ordinance could assist with economic development and assist the many homestead farmers in Gray. (12/17) Council discussed and support moving it forward for more discussion. (2/4) Council provided some general feedback on ordinance, issues with continuity to other ordinances and process (OAC route as starting point - or allowing group to do updates to move it along faster). Majority of Council felt it was important to move along as soon as feasible given the economic impact it can have on Gray. Agreed that Anne would compile specific feedback. (2/18) Councilors provided feedback (4/21) Draft updated ordinance has been sent to Alyssa. (4/28) Sandy adv Anne working on edits with group (5/5) Anne provided update on action since last meeting - updated version will be reviewed at next meeting. Group is requesting 'emergency' status due to the covid-19 situation. (5/19) Anne reviewed changes. Council had no feedback - majority supports. Did request more detail on level of risk identified by Alyssa on 2 provisions. (6/2) Council removed reference to Farmers Markets and approved on emergency basis. (7/21) Council extended emergency ordinance with Farmer's Market addt. Discussed proposed changes and agreed substantive. (8/4) Council rew add'l changes and agreed to move forward with them. (9/1) 1st read - council approved. (9/15) Council ext emergency to bridge gap in timing. <b>Next Step: 2nd reading set for 9/15 with public hearing. Will need to extend emer. ordinance again. (9/15) 2nd reading &amp; Council approval - ordinance will go into effect in 30 days. This item is CLOSED.</b>

\*Status: O = Open C = Closed F = Future  
 Priority: \*\*H = 1-3 months M = 4-9 months L = 10+ months

Last Update: 12/01/20

No	Goal/Category	*O/ F/C	** Priv	P No.	Target Date	Description	Sub By:	Owner:	Assigned to:	Dated Logged	Last Update	Comments
79	Ordinance	O	H	11	10/15/20	Update Mobile Vendor Ordinance to accommodate Food Trucks	Sandy Carder	Deb Cabana	Kathy Tombarrell	06/02/20	09/15/20	(5/19) Council discussed the fact that Food Trucks do not really fit in the Mobile Vendor Ordinance as they are more short term. Council agreed the ordinance needs to be updated as it was last looked at in the 90's and Food Trucks are a large part of the small business economy, allows for more food options for residents and are used to start new restaurants in some cases. OAC has a large list to work on. Kathy volunteered to take the lead. (6/16) Kathy pulled together some ordinances for the Council and asked some questions to obtain high level consensus and guidance on next steps. (7/22) Council reviewed draft from Kathy. (9/1) 1st read & council approved. <b>Next Steps: 2nd reading &amp; public hearing set for 9/15. (9/15) 2nd Reading &amp; Council approved - ordinance will take effect in 30 days. This item is CLOSED.</b>
38	Administrative	C	L	3	11/03/20	Prepare for mandatory Charter vote set for Nov. 2020.	Deb Cabana	Deb Cabana	Deb Cabana	09/18/18	11/17/20	Deb advised that a mandatory election question will need to be presented to the voters at the Nov 2020 election providing the option to (1) revise the Town Charter or (2) Keep it the same. (1/21) Deb advised Council needs to discuss if there will be any changes & that can be done any time. If changes are wanted, then a committee has to be formed (if substantive). (2/4) During prep for discussion, Deb/Sandy identified a discrepancy between State Statute and the Town's Charter related to how/when the 10 year questions must be posed to residents. It is not a substantive change. Deb adv Alyssa agreed a Charter amendment to fix the text issue can be done in June. There is a minimum voter turnout requirement. (4/21) Council set public hearing for 5/19. (7/21) Voters approved correction. Council made official. Will likely need Charter change as part of Town Manager job description work. (9/1) Alyssa advised that Job Desc changes are considered an amendment so Council can just put to voters in June without a committee. (9/15) Council approved ballot question. <b>Next Step: Will appear on Nov 3rd ballot. (11/17) Voters voted against a Committee on 11/3. This item is CLOSED.</b>
	Comp. Plan Update - breakout of tasks for Item 11	C	H	1	11/01/20	Identify strategy / approach for <b>Communication with Residents</b> - best practices for engagement - and ways to encourage attendance at workshops, brainstorming, committee meetings, etc.	Town Council	Town Council	Northstar	03/06/18	11/17/20	Anne Gass provided info on Oren Family Foundation which works with rural towns in the area of resident engagement & communication. Council agreed to investigate further when time comes (Bucksport has used). Bruce provided an update regarding the Heart & Soul informational session at GPCOG. 9/18 Doug presented council with overview from discussions with GPCOG/Heart & Soul and Windham. Heart & Soul facilitator to present via 1hour workshop at 5pm prior to Oct 16th meeting. (11/13) Council discussed & agreed Heart & Soul should not be pursued at this time. (1/8) Discussion held between Council & Doug on possible options. (2/5) Doug reached out to Jane & to Ben from Windham - any contract for a facilitator will include outreach. (2/19) Parameters provided for refined proposals from both Jane/Ben. (3/5) RFP to go out this week. Town rec'd 1 proposal. Council voted to accept proposal. (6/4) Contract reviewed & approved. (8/6) There was some discussion regarding meeting minutes which will be discussed further at a future meeting. (9/3) Northstar had a booth at the Bluberriy festival and has issued their first survey to residents. (10/15) Chair/VC provided update presentation to Council & public. (11/12) Visioning session held 10/19 & 10/22. (11/12) Committee will be moving into land use after first of the year. will begin videotaping meetings to ensure control of content. Deb looking into new table mics to prevent impact to Committee's work. (1/21) Comm has released 1st land use survey & set up public forum. (1/29) Open house held. (5/5) Ben prov uppd on Covid-19 impact to timeline at 4/28 meeting. Comm/Ben prov uppd at 5/5 meeting. Have new timeline to stay on Nov ballot. Council disc comm strategy.(6/2) Card sent to all residents, workshop held 5/26. Councilors approved state submission form. (9/1) State prov feedback & complete & consistent finding on draft plan. (9/14) Public hearing held. (9/15) Council approved plan & ballot question. (10/6) Council disc add comm options <b>Next Step: Voters to weigh in 11/3. (11/17) Voters approved 79% on 11/3. This item is CLOSED</b>

\*Status: O = Open C = Closed F = Future \*\*H = 1-3 months M = 4-9 months L = 10+ months

Last Update: 12/01/20

No	Goal/Category	*O/ F/C	** Prty	P No.	Target Date	Description	Sub By:	Owner:	Assigned to:	Dated Logged	Last Update	Comments
11	Comp. Plan Update	C	H	1.1	<a href="#">Detail Tab</a>	Evaluate options to update current <b>Comprehensive plan</b> including budget impacts to determine best course of action and set timeline. <b>SEE SEPARATE TAB - FOR DETAILS</b>	Town Council	Deb Cabana	Northstar	01/22/18	12/01/20	<p>Council has identified an update to the Comprehensive plan as a top goal. After reviewing the existing plan, feedback from the State planning office &amp; various other State agencies and new Comprehensive plan policies &amp; requirements, Council requested input from GPCOG which was presented at the Jan 8th TC Workshop. Town staff will work with GPCOG to develop possible options (with budget inputs) for moving forward. Options presented to TC (2/20). Council also signed on a step identified, will move this item to own 12/19/18 risk out individual tasks due dates: (11/13) Doug provided updates - see detail tab (1/8) Doug provided update on committee options. (1/22) Council discussed &amp; provided detail instructions to Doug. (2/5) &amp; (2/19) see updates. TC approved docs at 3/5 meeting. (5/30) Workshop held (6/4) Action taken (8/10) Northstar-Comm were at the Blueberry Fest (10/15) Chair/VC of Comm provided update presentation. Visioning session held 10/19 &amp; 10/22. (1/7) Sandy advised Ben will present an update to the Council at the 2/4 meeting. (1/21) CRC has released land use survey &amp; held open house 1/29 (2/4) Update to Council (4/21) Due to Covid-19 the Committee has fallen behind on the draft plan. Ben provided 3 options for moving forward to Council. More info is needed from the committee on the options and their comfort level with the options. Generally speaking, the Nov elec is still a goal, but there is a risk it will not happen &amp; concern with residents being able to fully engage/support the plan. (5/5) Comm prov update on plan &amp; Council agreed to send postcard to every Gray resident. (7/21) Update provided to council on next steps &amp; current status. (8/4) Council discussed &amp; voted to process add'l \$3,500 payment to Northstar for unexpected scope. (9/1) State has issued a complete &amp; consistent finding for the draft plan. Council prov feedback on Comm's planned outreach. (9/14) Public hearing held (9:15) GPCOG presented results &amp; changes from public hearing &amp; advised they felt an add'l public hearing was not needed. Council voted to approve Comp Plan with changes discussed in meeting &amp; approve ballot question. (10/6) Updated plan has been posted to website &amp; blast was sent out. Council sugg electronic signs, more e-mail blasts, social media posts, contacting LRW newspaper and large sign at the Transfer Station for add'l communications. (11/17) Voters appr by 79% on 11/3. Deb confirmed no add'l steps needed. <b>Next Step: Council will discuss implementation plan 12/1 (12/1) This item is closed - with a new item being logged for implementation. This item is CLOSED.</b></p>
71	TIF Goal / Budget	C	H	5	12/31/20	Amend <b>Route 100 South TIF</b> to address funds	Town Council	Town Council	Town Council	02/04/20	12/01/20	<p>Council has met several times in Executive Session to discuss the Route 100 South TIF. (1/21) Council held Workshop with Water District to review status. As currently defined, the money collected in this TIF fund cannot be spent as no current project meet the definitions. If Town does not rectify, could face issues with the state including retroactive reassessment of state revenue sharing and fines. Other Towns have faced these situations. Council has two options (1) amend the TIF to expand definition to include new project and allow to expire as written (2) amend the TIF to expand def to incl new project and close down early. During the workshop GWD &amp; Council agreed the Rt 115 project would be the best option as it is a high priority, safety issue, critical to the village and includes water line upgrade and stormwater infrastructure. The issue of timing - when would the MDOT be ready to work on the project, when would plans be ready &amp; MPI timing were discussed. Agreement was to ask Alyssa if we could (1) amend to include RT 115 project and (2) set a new expiration date - not full term but not close immediately - likely 3-4 years. (2/4) Deb adv Alyssa said it is possible, but needs to review detail with Council. (3/10) Agree reach, Amend TIF to include Route 115 project and add'l list of top 4-5 WD priorities. Leave term intact but add verbiage to close the TIF once money is expended. Letter to ME CDC would be done to address outstanding bond at closure. (3/24) WD sent priorities to Alyssa, but Covid-19 has taken priority. Council voted to set public hearing 4/21 to give more time. (4/21) Council moved public hearing to 6/2 meeting. (4/28) Council rev warrant article. (7/21) Voters approved funding (10/6) State submission is complete. (11/17) Deb adv State needed a few updates. <b>Next Step: Awaiting State approval. Council to set up workshop to discuss project. (12/1) State has approved the amendment. Route 115 project already logged separately. This item is CLOSED.</b></p>

# BUDGET ITEMS

No	Items Label	Cost Est.	Task No.	Description	Comments
1	Pocket Park	(2020) Grant + \$2,175 + \$3,300 in Public Works Dept	#69 M10	Gray Historical Society has a long term vision of creating a <b>Historic Walk</b> with the Pennell House Memorial (re: Cumberland Farms donation/lease/ment) kicking off the effort. GHS would like to discuss the <b>Town Owned Property at 5 Yarmouth Rd</b> as a <b>possible mini-park</b>	GHS in planning stages with more information will likely be available in January. Goal is to have full trail mapped out to identify specific locations as historically important for consideration when future development is planned. (10/28) Council needs more info, GHS/CEDC both have some ideas for the space. Council has RT115 project review starting, there is some thought to put up guardrails to prevent in appropriate vehicular traffic, Anne mentioned there could be grant money avail to help with developing a plan. Council agreed to keep on list pending presentation from GHS/CEDC in near future. (12/17) GHS/CEDC presented to Council & advised of possible Grant applications for funding which will be presented at the 1/7 meeting. (1/21) Council voted to approve grant application with direct \$2,175 match & \$3,300 of public works time/costs
2	Education Funds	\$5,250 per semester - \$0 in 2020	N/A	New <b>continuing education fund policy</b> was approved allowing for up to \$5,250 per semester in reimbursements per qualified employee studies. Benefit is dependent on available funds.	Policy includes request for submissions to allow for proper budgeting. Deb advised deadline for submissions is January. She will provide info on any budget requirements. <b>Employees had until Jan 19th - request included in Individual budgets.</b> (10/28) Deb advised no employees have submitted request - thus no funds needed this year.
3	Employee Vacation/ <b>Sick Fund</b>	(2020) \$35000	N/A	As of June 30, 2017 the <b>Town's Liability for compensated absences</b> - this is an unfunded liability and comes into play when an employee retires or leaves and requires a payout of <b>accumulated vacation/sick time</b> .	There is no designated fund for total \$245,419. Deb advised Town spent \$18,000 on retirements last year (unfunded). Council discussed setting aside 10% (\$25k) or 15% (\$37k) annually to start. Council is looking at \$25,000 Manager Contingency fund as first step in this funding. (10/28) Council agreed further payments to close gap should be considered. (2/18) Deb advised she is seeking \$25,000 for this fund - separately from the Contingency fund as with pending retirements, it is likely the \$25,000 will be exceeded. (2/28) Katy advised she added another \$10,000 and stated we cannot reduce as it will all be spent next year plus likely the contingency fund. (12/15) Council wants to review & possibly update sick time accumulation policy - currently unlimited.
4	CIP Payment	?	N/A	2018 CIP Bond package was put together to allow Town to make <b>payments to the CIP fund</b> over a 5 year period. The \$100,000 remaining outstanding from the 3/12ths rainy day fund is being logged separately - see below.	Need to determine the status of the \$500,000 repayment to rainy day fund. Need to determine what the annual payment is based on CIP 15 year projections over the 5 year period. Deb will have more info on repayment after new year. Council identified as top priority & Sandy expressed desire to ensure CIP has everything included before the calculated payment is worked on. Mo advised there was some equipment missing which has now been added. Discussed approaches to payment calculation including using an inflation rate of 4%. Council identified the possible \$100k gained from resale of old ladder truck as CIP payment - as voted on by residents. In addition, Council agreed to move \$100k into CIP from the \$500k payment into the 3/12ths - to use projected overage next year to finalize the \$500k re-payment. (10/28) Old ladder truck is now for sale. Council agreed to ask Finance Committee to come up with "fully funded" number to better understand the gap between current \$100k - for discussion purposes. (12/17) Deb adv \$85,000 rec'd from sale of old ladder truck and \$10,000 rec'd for sale of retired equip for total of \$95,000 for CIP fund. (2/13) Deb & Katy provided updated CIP information to Council. (4/2) Council agreed need to review/update fiscal policy after budget season to look at bonding larger, long term equipment items - will change CIP funding. \$42,570 interest going into CIP from bond, but will be used for paving. Agreed to keep funding at 1,850,000 with final review after final numbers provided. (4/28) Sandy re-raised the option presented by Deb/Katy to reduce the CIP payment by the \$42k interest payment as a way to reduce the overall increase on the operations side. The add'l paving could be pushed off or could be done with the result being the CIP end balance would be reduced by \$42k. Majority of Council wanted to stay the course & not pursue this option.

No	Items Label	Cost Est.	Task No.	Description	Comments
5	Watershed Plans	\$18,000 (2018) \$5,000 (2019)	N/A	\$12k for Thayer Brook & \$6k for Cole Brook were approved in last year's budget. Cumberland County Soil & Water Conservation District has identified other watersheds that need surveys and/or protection plans.	Doug advised contracts have been signed & surveys will be underway shortly. Some discussion was made about what other watersheds need attention. Doug will reach out to CCS&WC to ask for input and estimated costs for next steps. Awaiting report back from initial watershed study for next steps and costs. (8/6) CCS&W will be doing a presentation in Sept to provide an update & next steps. (10/28) Presentation has been pushed to December. Council asked if CCS&W would provide feedback on other necessary watershed studies and estimates - in addition to any monetary impacts from completed studies. (12/17) CCSWD presented results of study to Council along with recommendations. Council asked for est. for each task (ballpark), as well as, ISWG fees. (12/18) Katy provided the Watershed estimate document to the Council which is set to discuss it at the 3/26 workshop. (3/26) Council reviewed and would like Doug & CCS&WC to prioritize top tasks & resubmit lower budget. (4/2) Doug provided update - split in two piece with each about \$13k. Council would like tasks (1) from each proposal for this year & then the rest for next year to balance addressing current water quality issues and preparing for future impacts - revised cost \$7,200. (4/9) Kathy advised after re-reading proposals she better understands why Heather is recommending items 1-3 first before doing ordinance work. Will get clarification & bring to 4/16 meeting. No impact to bottom line as part of CIP. (4/21) Kathy rev with Council, and Council agreed to go back to the original 2 tasks - but only do task #1. With the grant funding the remaining tasks would be done the following year & after Task #1 is complete, the Council will have a better handle on when task #2 should be done.
6	Sidewalks - Libby Hill	\$115,000 plus - 20% of total?	N/A	MSAD15 has expressed interest in a joint effort in developing project plans for new sidewalks between Middle & High Schools on Libby Hill Road for possible grant application/approval for outside funding.	Council discussing top priorities from Public Works, included in Bike/Ped Plan and from MSAD15 standpoint. State grant programs require an approved project plan and as specific % of the funding approved & set aside before applying for remainder of funding. Joint leaders meeting with MSAD15 being worked on again. Steve included the Russell School piece in his engineering request for Shaker Rd (see item 25B). Dan also recommended a 'standard' be derived for all future sidewalks - covering things like width, grade, ADA requirements, etc. Steve advised he could work with Will to create a standard. Council will budget for engineering & roll this into the Shaker Rd project - see 25B below. 20% of funding would be considered in future budget once total cost is known. (10/28) Council asked to have Will provide estimate for engineering costs. (03/12) Council agreed because we are expending substantial funds for the Shaker Rd sidewalk project, this one will need to be deferred. Alec also advised the existing sidewalk would need to be redone as it is not ADA compliant.
7	Public Facilities Study	\$44,000	N/A	\$23,000 was approved in 2018 budget to conduct a Public Facilities Study on current capacity and projected capacity needs. (Public Safety Study)	Mo used Windham's recent study and did a rough draft to obtain quotes; a larger sum (\$56k) will be needed to complete this & the study was not as detailed as needed. Staff recommends breaking this into two pieces - Public Safety & All Other. Public Safety piece may require a specialty consultant. Staff will do more work to present options to Council. \$23k has NOT been spent and could be rolled over & added to - to cover options. Council cut this from the budget - anticipating doing it next budget. (10/28) Deb advised she engaged with a contractor to complete the Public Safety piece in this year's budget and will provide an updated estimate for other departments. (3/26) Council agreed that this should be pushed off 1 year so the new Manager can participate.

No	Items Label	Cost Est.	Task No.	Description	Comments
8	Broadband Partnership		N/A	Lakes Region Broadband Partnership along with Cumberland County are working on the <b>Connect Cumberland project to extend broadband</b> through major corridors. <b>Updating this to possible funding needed related to Grant being pursued with W/ndham.</b>	A presentation was made to the Council during the July 3rd, 2018 meeting. Costs are unknown at this time, but goal was to have more information by year end for budget planning. No update on costs at this time. (10/28) Deb advised the group was having difficulty finding a contractor to do the work and thus will not be included this year.
9	Skateboard Park	(2020) \$15,000	N/A	A GNG Student reached out to the Town asking for consideration of a <b>Community Skateboard Park</b> . Partner with school?	Dean was working on pulling together information from other Towns with skateboard parks to provide cost estimates. May be funded by the recreational enterprise fund. Dan advised Mike L. at HS has a group of students working on this and he has given them the timeline for budget season. He expects they will reach out after the new year to come in for a presentation. \$25,000 estimate provided - but could be more - Council agreed need more advance work, possible Community group & fundraising before included in Town's budget. (10/28) Dan advised this is still be worked on. Council agreed until they are ready to present a plan both for the park and the fundraising piece, this will not be considered. (1/21) Officer Chadler will present at the 2/4 Council meeting. (2/4) Presentation made to Council, majority supports project, requested a full blown proposal with estimated budget before next steps could be determine. The funding will need to be grants, fundraising & the Town. Location will be critical. (2/27) Rec dept is requesting \$15,000 (out of estimated \$125,000-130,000) to start the ball rolling on planning & fundraising.
10	Land Acquisition Fund	(2019) \$50,000 (2020) \$25,000	N/A	A <b>Community Center</b> has been discussed in various meetings and may be related to the above (13) Public Facilities Study - as far as next step planning.	May be funded by the recreational enterprise fund. Recently notified of 2 residents (Carrie Carter & Steve Morse) who have obtained a license from the state and are looking at setting up a Committee. This is tied to both the Comprehensive Plan and Item 13B as a review & input from residents in need to determine need, size, location, priority, etc. Deb did advise that Newbegin is in need of substantial upgrades to make it more efficient and capacity has been breached. See 32 below - would roll into Land Acquisition fund. (8/6) The Council asked Deb to reach out to the owner of the Hamilton property to inquire about options for the Town - whether that is a community center with municipal parking, fields, or housing - or a combination of them - is unknown at this point & will require further discussion. (10/28) Council has this on their workshop list. (3/12) Council has set a workshop on 3/31 to discuss the status of the Hamilton Property and Land Acquisition funding. (3/31) Council discussed and agreed it is a great opportunity and Town should move to engage owners in an option contract to give us time to collaborate with GNG/L, Royal River, etc. to develop plan, seek resident input & approval and create a funding plan. (4/2) Council was provided with valuation info & will discuss land acquisition fund at 4/9 meeting. (4/9) Council discussed tentative steps for Hamilton property is to identify funding in this year's budget, then between now & possibly Nov election, working on more details for concept plans and identify funding options which could be used to seek residents feed and a vote with Nov election. Council agreed to set \$50,000 again as separate question. (4/28) Council agreed to reduce to \$25k and to list as part of the CIP warrant article.
11	Dog Park		N/A	A suggestion was received to establish a <b>Town Dog Park</b> on the capped land fill. After some discussion, it was determined it was not a good fit; however, another location may work, if there is support.	Council agreed this is not something that will be pursued in this year's budget. (10/28) The land fill is no longer an option due to the pending solar array. No further requests have been made, thus it will not be considered this year.

No	Items Label	Cost Est.	Task No.	Description	Comments
12	Speed Signs	\$8,325 speed sign \$15,250 for text & speed combo sign	N/A	The Town owns one speed sign. Discussions about purchasing others - that mount to utility poles with flashing lights and "slow down" with the speed have been discussed.	The one sign Gray owns was obtained via a grant. Steve can obtain some costs estimates for a similar one and/or those mounted on utility poles. Also, Deb advised deputies have asked the Town to look into School flashing lights for Shaker Rd as it is difficult for them to enforce without them. MDOT has said we can install. Steve will obtain prices. Dan suggested we also calculate what % of time is dedicated to speeding & provide more information to residents. Steve did advise the sign does record & the data is given to the Sheriff's office. Signs for school zone on hold pending Fiddleheads status - others will need to wait for future budget. (10/28) Steve advised he found a different vendor - same sign - mount on trailer version which is in the \$3-4K range. He feels these are more effective than the pole mounted ones as people get used to those. The current sign has been damaged and will likely not be repaired until spring. (2/4) Fiddlehead's charter school is not relocating - they are buying the building & the center will be relocating. Council will need to discuss school signs again. (3/12) Alec advised the cost is closer to \$5,500 to purchase a new hybrid sign that has radar measured capacity as well as construction messaging capacity. He advised it does track data - but the computer it is using is very old. Council would like data at least reported out after each usage. Alec advised it is shared with the Sheriff but they do not maintain the data. (3/26) Alec provided \$8325 price for speed sign only or \$15250 for construction type sign with speed & text. Council believes the multipurpose sign is a better value - but may want to wait until next year. Council will consider once Shaker Rd project costs known. (4/9) Majority felt there is likely value in having add'l sign, but majority also felt it could wait given the existing sign is now fixed & ready for use again and we are purchasing a radar gun for the deputies.
13	Planning /Engineering	N/A	#4 M3	TIF Projects (Main Street, Village Shaker Rd, Route 115), Sidewalk projects, and other projects (Wilkie's Beach) require engineering work to develop plans before funding can be sought (or to have more pull with MDOT/MTA).	Steve projected \$75K for engineering work for the Route 115 project, but Will advised that the engineering costs need to be included into the project request - if we go with MPI program - where MDOT would pick up 50% of costs - up to \$500k. Project is estimated at 1 million. Therefore, no budget impact for this fiscal year. Gorriil Palmer provided \$91,000 design fee & \$62,000 full time construction inspection fee as estimates - but would provide a new proposal when the Town decides to proceed. Given item 25B will likely use up TIF funds for this year, this will be considered in a future budget (with evaluating the intersection at the same time). (12/17) Public forum held on 12/5 - Council to set workshop. (3/26) Council is working to amend Route 100 South TIF to allow for funds to be used on this project. (4/21) Council set public hearing for 6/2 to put out to voters at 7/14 election.
14	Construction Costs	\$88,400	N/A	Extending sidewalk from Hannaford - Spruce Street - Sidewalk projects, and other projects (Wilkie's Beach) require engineering work to develop plans before funding can be sought (or to have more pull with MDOT/MTA).	Steve is requesting \$13,770 for construction costs to extend the sidewalk from Hannaford to Spruce street (engineering has already been done). (2/13) Alec provided estimate which includes engineering, construction, crosswalk from Spruce to School walking path, tree removal/stone wall relocation & possibly drywell = \$88,400. Council set to discuss at 3/12 workshop. (03/12) Council agreed because we are expending substantial funds for the Shaker Rd sidewalk project, this one will need to be deferred. Alec also advised the existing sidewalk would need to be redone as it is not ADA compliant. Alec also advised work new the pathway would like need to be added to this project due to stormwater issues.

No	Items Label	Cost Est.	Task No.	Description	Comments
15	Contingency Fund	\$25,000	N/A	Many Towns (and most companies) incorporate a <b>Contingency Fund</b> into their budget planning to cover unforeseen expenses.	<p>Deb provided (2) examples - \$18K for unfunded vacation/sick time for retirees and \$10K for the stormwater video work on Main Street. She has to cut from other parts of the budget which means other tasks go undone &amp; must be refunded in subsequent budgets. Many municipalities have these funds to address unexpected or emergency situation. Another one is storm clean up for Public Works. Council discussed between \$20-30K. Council agreed to tentative \$25,000 amount to cover projected retirement and have some left over. (10/28) Council funded this as a combination of employee time &amp; contingency - agreed we need to continue working on this fund. (2/18) Deb advised she is requested \$25,000 for this fund separate from vacation/sick time outstanding liability. (2/27) Katy advised we will likely spend this to supplement the vaca/sick time fund. (4/2) Deb advised it could cost up to \$10K for an add'l election if we miss the 6/9 election. Katy advised the money in this year's budget for that election would flow into the unassigned but would not be accessible until the following year's budget cycle after the audit was completed. Council needs to consider adding \$10K to contingency. Katy advised that contingency is set aside to help with transition to new Manager. (4/9) Governor will be moving election to July 14th - we will move local to coincide. Ballot printing, machine programming will be in current budget, there may be some money needed for staff time. Council agreed to keep contingency fund at \$25,000. Election change is another example of why a contingency fund is needed.</p>
16	Senior Tax Relief Program	\$30,000	#53 H8.1 @	There was limited discussion about a possible <b>Senior Tax Relief program</b> for the elderly property owners.	<p>Other Towns have adopted them - an example - 70 years old, residency for 10 years and up to \$XX of reduction in property taxes. Sharon shared another example of parameters for such a program. Dan expressed concerns with using funds for other priorities. Means testing would be a requirement &amp; it would have to be a principle resident. One goal is to avoid tax liens &amp; subsequent forfeiture of the property - State just passed legislation to make it much harder for towns to force eviction due to unpaid taxes for seniors. Council would like more information on impact. Sharon proposed a \$25,000 starting fund, but Council wanted to work out details of program before considering as a budget item. (4/4) Council discussed again with increase to \$50,000 proposed by Sharon. Council did not agree to add to the budget as increase is already large &amp; would like better handle on sustainability/costs (Cape - \$75K, Cumberland \$65K). Council could not identify items to scratch from budget to compensate for needed funding. (8/6) Workshop held. (10/28) Council has another workshop to determine if consensus can be reached on program parameters. (12/17) final changes discussed - 1st reading set for 1/7. Approved at 1/21 meeting. (3/26) Sharon is req \$30K for this fund. Sandy/Dan want to delay. Bruce/Anne want to reserve decision until final number crunching. (4/16) Majority of Council felt this new service should not be added this year given the current situation and strain on other taxpayers - not on a fixed income - who may be losing their jobs, etc. A request was made to put it on the ballot as a separate question, but only 2 Councilors supported.</p>

No	Items Label	Cost Est.	Task No.	Description	Comments
17	Paving	(2020) \$469,250	N/A	Need to review <b>Paving budget</b> process to ensure projected & actual are closer	Paving has been increasing in costs the last several years with 'asphalt escalation fees' built into the contracts. This means projected jobs (4 roads) may not match what actually is paved (3 roads) as money runs out during the season. Either need to increase paving budget or need to identify 'definite' vs. 'maybe' roads in the process or select fewer roads. Need to keep engineering report in mind to ensure Town stays ahead of falling road projections. (10/28) Steve will adjust request - to ensure we get 'caught up' on our paving - as a starting point. (2/27) Figure excludes \$13,500 being requested for pavement condition study. (3/12) Council discussed request for study. There is no industry standard - and last study was done 2017. Alec said roads that have been paved in last 3 years would need a study to determine their updated status. Council asked for est to do just those roads vs. a full study. (3/26) Alec checked into reducing study & only option is to break down into districts to do one each year - but that will likely cost more overall. Council agreed it needs to be done by next year at latest, but need to push this year.
18	Libby Hill	(2020) \$13,579	#27 H1.2	Need to determine long term obligation and budget funding for <b>Libby Hill maintenance</b> for Town's portion of acreage	Work has begun on the Libby Hill deed review. That will include work on a maintenance agreement between the Town, MSAD15 and the Community Endowment. An informational meeting between the 3 parties is being scheduled. Need to determine how much annual funding will be needed for Town piece and what changes need to be made to CIP schedule. (10/28) Dan was assigned as liaison and the first meeting is set to work on identifying the costs. (12/3) Council discussed again & agreed should be on list. (2/27) Increased by \$2,527 for total of \$4,027 plus tractor in Mo's budget to assist. (3/12) \$4752 winter operations plus \$4800 spring operations = \$9,552. Requested Pavillion budgeting will likely be deferred until MSAD15 identifies their funding.
19	Rainy Day Fund	(2020) \$25,000 (2021) \$75,000	N/A	Need to <b>replay 3/12's fund</b> to make it whole	(10/28) \$500,000 was taken from the 3/12's fund to help purchase the new ladder truck. \$400,000 was paid back in 19-20 budget cycle. \$100,000 remains outstanding and needs to be paid back - within the next 4 years. (4/2) In our 3rd year to pay back over the 5 years total - Council agreed to only pay \$25k this year and look to pay remaining \$75k next year once more is known about the economic downturn.
20	Traffic Calming Measures	??	N/A	Add <b>traffic calming measures</b> as part of the project planning & designs	(10/28) Bicycle Coalition of Maine provides these items free of charge for testing; however, if Gray does decide to proceed with formal measures, equipment and/or construction costs may be incurred. (3/12) Anne advised it will take through the summer to set up tests and to identify what, if any, traffic calming measures will be recommended and then to determine costs. Will be considered in next year's budget.
21	Library Heating System	?	N/A	<b>Library Heating System</b> may need to be replaced in 5 years	(2/27) Mo advised increasing maintenance costs are being experienced with the Library boiler which should last another 5 years and recommends a future replacement to a version that has fared better in the other public buildings and is less costly to maintain - at a cost of around \$20,000. We are/will spend \$5,000 a year during the 5 years. Discussed the option of just replacing now - Mo clarified system is more complex and has more splits because of the layout (original building & addition). Council wants to make sure future update/conversion is covered in CIP.
22	Automatic Fuel Shutoff	?	N/A	Should systems be <b>upgraded to automatic shutoff</b> options	(2/27) Dan reminded Council that during the CZA process with Cumberland Farms an automatic fuel shutoff system was discussed (more costly) vs. having personnel being responsible for quickly (and correctly) shutting down systems to prevent a spill or minimize one. More research needed to determine costs/viability vs. benefit.

No	Items Label	Cost Est.	Task No.	Description	Comments
23	Fencing	?	N/A	Need to <b>add Fencing to CIP schedule</b> - applicable departments	(4/9) Dan pointed out that existing Town owned fencing does not appear to be included in any of the CIP department schedules. Council agreed it should be added before next budget cycle.
24	Existing Sidewalks	?	N/A	Need to <b>add all Existing Sidewalks to CIP schedules</b>	(4/9) Sandy pointed out that existing sidewalks are also not listed in the CIP schedule for maintenance/reconstruction work. Town has been only addressing when applicable roads come up for paving - usually nothing is done when overlay paving is done - creating a situation where they are only being addressed when a road is reconstructed. By that time, sidewalks are in bad shape and add considerable costs to the road budget. Need to put money aside to ensure existing sidewalks are maintained and funded when reconstruction is needed.
25	Paving Plan	?	N/A	Create a <b>long term Paving Plan</b> to "catch up" with recommended schedule	(4/28) Dan suggested that between now & next budget, the Council ask Alex to create a long term paving plan - through 2035 perhaps - to identify a route to catch up on the backlog of paving. This could be used in conjunction with the planned road study (next budget cycle) to ensure progress is made each year.
26	Livelong Living	?	N/A	Placeholder for 21-22 FY Budget - <b>Senior Programs</b>	(8/4) Logging as a placeholder pending presentation from Lifelong Living Committee in Fall/Winter
27	LD1	N/A	N/A	Discuss impacts of LD1	(9/15) Council agreed to log to ensure discussion on how to mitigate issues with LD1
28	Enterprise Fund	?	N/A	Need to evaluate impact of <b>Covid on Enterprise Fund</b>	(9/15) Deb has advised current projections have fund just breaking even or with a small revenue amount.
29	Communications	\$18,910	N/A	Consider proposal from Community Communications Committee to use <b>Franchise Fees for Equipment</b>	(10/6) Anne advised the new Committee would like to see the newly discovered underpayment of franchise fees (\$18,910 for 2 years - more to follow?) put towards purchasing new/more equipment to improve the use of the Community Television Station and other platforms.
30	Public Safety Study	?	N/A	Review <b>Public Safety Report</b> to determine funding needs for changes	(10/6) Deb shared the report created from the Public Safety Facilities study which contains many recommendations. Some will flow through department budget process, but others may require Council action with possible funding implications.
31	Stripping	?	N/A	<b>Shaker Rd Project</b> - new <b>stripping</b> - increase to annual budget	(10/6) As part of the Shaker Rd Stormwater/sidewalk project, new stripping was discussed - reducing lane size to create official bike line with proper stripping, crosswalk addition, additional traffic calming - will add to existing stripping on the road.
32	Electric Charging Station	?	N/A	Consider installing an <b>electric charging station</b>	(12/1) Sandy advised she would be bringing this forward given the new solar array will be going online. Long term, if Town buys the array, converting as many vehicles as possible to electric will save more costs. First step would be installing a charging station - may be grants or other funds available to assist with cost.
33	Electric Vehicle Transition	?	N/A	<b>Transition Municipal vehicles to electric versions</b>	(12/1) Sandy advised she would be bringing this forward given the new solar array will be going online. Long term, if Town buys the array, converting as many vehicles as possible to electric will save more costs.
34	Trees??	?	N/A	<b>Shaker Rd Project</b> - <b>new canopy trees</b>	(12/1) Council discussed plan for tree canopy on Shaker Rd. Several trees are being taken down for the project. Kathy was going to pull a canopy inventory and then complete an analysis of which trees are slated to come down to help identify where new trees may be needed. The species also needs to be identified. Council discussed putting the costs in the project itself or potentially handling outside the project after completion. This is being logged as a placeholder.

21-22 Budget Items

Last Updated: 01/05/2021

No	Items Label	Cost Est.	Task No.	Description	Comments
35	Signs - Libby Hill	?	N/A	Update "No Public Access" sign - Libby Hill	(12/15) Sandy pointed out that the current sign (unknown if it is the Town's sign or home association sign) at the start of the private road which states "no public access" is hard to read and to verbose. Homestead Acres Assoc has complained about people parking on the road to access the Town's LH trails. Consider updating the sign to be more clear or adding "use trail heads" signs or "no Parking" signs.
36	Illumination Tool	\$2,000	N/A	Purchase illumination measurement device for code enforcement	(12/15) With new sign ordinance illumination restrictions, Code Enforcement will need equipment to ensure compliance. (1/5) Dan believes the tool will be about \$2,000
37	Grant match	? \$ - In kind	#75 HZ	Fund grant match for Long Hill ATV trail	(1/5) Anne advised that she is pursuing other grants for the ATV trail rehab on Long Hill Road. The grants will require a 20% Municipal match - which can be met with "in kind" donations and the ATV Club may be able to provide that match via labor/equipment. The timeline is April/May deadline.

## BUDGET FY 2021/2022 DEVELOPMENT TIMEFRAMES

**UPDATED – JAN 10, 2021**

FEBRUARY 2, 2021 (Tues)	<b>4-6 PM BUDGET WORKSHOP (1)</b> Administration/Assessing
FEBRUARY 2, 2021 (Tues)	<b>7 PM REGULAR TOWN COUNCIL MEETING</b> – NO Workshop 6-7 break PROPOSED DRAFT BUDGET TO COUNCIL (Includes C.I.P. Budget)
FEBRUARY 11, 2021 (Thurs)	<b>4-6 PM BUDGET WORKSHOP (2)</b> (Sharon vacation) Comm & Info/Maintenance/Recreation
FEBRUARY 16, 2021 (Tues)	<b>7 PM REGULAR TOWN COUNCIL MEETING</b> – Comp Plan WS 5:30-7pm
FEBRUARY 18, 2021 (Thurs)	<b>4-6 PM BUDGET WORKSHOP (3)</b> (Sharon on vacation) Recreation/Transfer Station/Public Safety
MARCH 1, 2021 (Mon)	<b>4-6 PM BUDGET WORKSHOP (4)</b> Public Works
MARCH 2, 2021 (Tues)	<b>4-6 BUDGET WORKSHOP (5)</b> Community Dev/Code Enforcement/TIF/CIP
MARCH 2, 2021 (Tues)	<b>7 PM REGULAR TOWN COUNCIL MEETING</b> – NO Workshop 6-7 break
MARCH 9, 2021 (Tues)	<b>4-6 PM BUDGET WORKSHOP (6)</b> Library/Comm & Boards/Comm Service/Law Enforce/Misc
MARCH 15, 2021 (Mon)	<b>4-6 PM BUDGET WORKSHOP (7)</b> Follow-up/Council Discussions
MARCH 16, 2021 (Tues)	<b>7 PM REGULAR TOWN COUNCIL MEETING</b>
MARCH 22, 2021 (Mon)	<b>4-6 PM BUDGET WORKSHOP (8)</b> Outstanding/Final Adjustments
MARCH 22, 2021 (Mon)	LATEST DATE FOR NOTIFICATION (Publish date March 26 <sup>th</sup> )*
MARCH 24, 2021 (Wed)	<b>4-6 PM BUDGET WORKSHOP (9)</b> <b>IF necessary</b>
APRIL 6, 2021 (Tues)	<b>7 PM REGULAR TOWN COUNCIL MEETING</b> COUNCIL BUDGET GOES TO FORMAL PUBLIC HEARING. REQUIRES THAT WE PRINT/DISTRIBUTE BUDGET FOR A PUBLIC HEARING WITH NOTICE.*
APRIL 12, 2021 (Mon)	<b>4-6 PM BUDGET WORKSHOP (10)</b> Warrant Articles/Flyer/Communication plan
APRIL 20, 2021 (Tues)	<b>7 PM REGULAR TOWN COUNCIL MEETING</b> <b>APPROVAL OF WARRANT ARTICLES</b>
MAY 4, 2021 (Tues)	<b>7 PM REGULAR TOWN COUNCIL MEETING</b>
May 18, 2021 (Tues)	<b>7 PM REGULAR TOWN COUNCIL MEETING</b> <b>Approval of Municipal Warrant</b> Appointment of Warden for Election
JUNE 1, 2021 (Tues)	POSTING OF WARRANTS- (MRSA 30-A, §2523 - 7 DAY notice)
JUNE 8, 2021 (Tues)	TOWN ELECTIONS - SECOND TUESDAY IN JUNE

Tues – Jan 12<sup>th</sup> – 4-6pm:

**-Town Manager Items:**

- COLA raises status
- Education Fund requests
- Flat funding or overall percentage increase
- Direction regarding budgeting for Public Safety Safer Grant
- Standardized form for Department Heads

**-Staff Items:**

- Ensure fencing is included in CIP
- Ensure exiting sidewalks are included in CIP
- Long term pavement plan – to catch up – status (Public Works set for 3/1 workshop)

**-Council Items:**

- Employee sick time policy (accumulation/carryover)
- Fiscal Policy – CIP/large project funding (bonding)
- Broadband – grant with Windham/other
- Dog park
- Senior programs – additional funding requests

Tues – Feb 2<sup>nd</sup> – 4-6pm:

**-Presentation of initial budget:**

**-Administration Review:**

- Health insurance increase
- HR Discussion - update
- Accrued sick/vacation time fund / Contingency Fund
- County budget timeline change
- 3/12<sup>th</sup> payment - \$75,000 deadline
- Status Cable Franchise fee recovery/contract/funding
- Elections
- Utilities

**-Assessing:**

Thurs – Feb 11<sup>th</sup> – 4-6pm:

**-Communication/Information Department: (4-4:30pm)**

- Committee request to use recovered Cable fees for equipment

**-Maintenance/Recreation Department: (4:30-6pm)**

- Realignment with Rec Staff (grounds/fields)
- CIP items (in bond/other)
- CIP payments (1) BB court lights (2) skateboard park (3) field reconditioning
- Update CIP (1) vinyl coated fence (2) full replacement/erosion prevention boat ramp – Wilkie's
- Status Science Building
- Dry Mills Schoolhouse repair – status of allocated funds
- Library heating system update
- Automatic fuel shutoff – Dan
- Fencing in CIP schedule
- Libby Hill maintenance

-Long Hill Rd ATV grant match

Thurs – Feb 18<sup>th</sup> – 4-6pm:

**-Recreation Department: (4-4:30pm)**

- Enterprise fund update/projection
- Childcare Program update
- Recreation Program Director status
- Status playground grant

**-Transfer Station Department: (4:30-5pm)**

- CIP items (in bond/other)
- Increases in contracts, if any

**-Public Safety Department: (5-6pm)**

- Operations & CIP items (in bond/other)
- Public Safety Report changes/budget items

Mon – March 1<sup>st</sup> – 4-6pm:

**-Public Works Department:**

- Paving (1) last year's status (2) this year (3) road study – new estimate
- Paving – long term plan
- Winter/Summer Roads/Addt'l/Garage – changes only
- Striping – new approach/addt'l for Shaker rd? other?
- Shaker Rd Project – status/trees/other?
- Speed/construction sign – pushed from last year
- Libby Hill Rd sign (No Public Access)?
- Pocket park – included in Public Works budget
- Ext of Hannaford Sidewalk on Route 26/Libby Hill paving/sidewalks (Other submitted) – status grant?
- Traffic calming measures – devices

Tues – March 2<sup>nd</sup> – 4-6pm:

**-Community Development/Code Enforcement:**

- Pocket Park – status
- Stormwater modeling – status
- Facilities Study
- Watershed – update from CCCS&W/new requests
- Illumination Tool
- Training – Planning Board/ZBA

**-TIF:**

- Route 115/Yarmouth Road expenditures (Route 100 South TIF)
- Village TIF funds

**-CIP:**

- All remaining items
- Land Acquisition Fund

**-Follow-Up:** On items logged during workshops

Tues – March 9<sup>th</sup> – 4-6pm:

- Library:
- Committee/Board requests:
  - CEDC Budget request
  - Blueberry Festival Committee
- Community Service: (including Lake Association requests)
- Law Enforcement:
- Senior Tax Rebate program (separate question on ballot)
- EV Charging Station/Electric Vehicle conversion:
- Follow-up:
  - Items logged from previous workshops
- Revenue Sharing/Excise Tax Forecast:
- LD1 Status:

Mon – March 15<sup>th</sup> – 4-6pm:

- Follow-up:
  - All outstanding items
- Council Decisions:
  - CIP Payment
  - Make Sub D / Enterprise funding decisions
  - Individual Councilor proposals – for changes
  - Identify final changes for Katy to make for March 22nd meeting – final numbers to be agreed upon then

Mon – March 22<sup>nd</sup> – 4-6pm:

- Outstanding Tasks:
  - Review final numbers for overall budget
  - Review Council list for outstanding
  - Determine impact to MIL Rate
- Council discussion on overall budget:
  - Make final adjustments – straw poll on budget
  - Agreement on ‘separate question’ items
  - Presentation material content – April 6<sup>th</sup> TC meeting – packet due March 29<sup>th</sup>

Wed – March 24<sup>th</sup> – 4-6pm:

- If necessary - Workshop – to wrap up figures for Public Hearing Presentation set for April 6<sup>th</sup>.

Tues – April 6<sup>th</sup> – TC Meeting – 7pm – Budget Presentation & Public Hearing – feedback from Residents

Mon – April 12<sup>th</sup> – 4-6pm:

- Discuss any feedback from Public Hearing on April 6<sup>th</sup>.
- Finalize specific requests for wording of warrant articles for April 20<sup>th</sup> TC meeting – packet due April 12<sup>th</sup>
- Draft of Budget Flyer/timeline

Tues – April 20<sup>th</sup> – TC Meet – 7pm – appr of Warrant Articles/May 18<sup>th</sup> – TC Meet – 7pm – appr Municipal Warrant