



TOWN OF GRAY
GRAY TOWN COUNCIL
AGENDA • AUGUST 2, 2022

**Gray Town
Council Regular
Meeting**

Town Council Chambers
24 Main Street, Gray, ME 04039
<https://us06web.zoom.us/j/83548357175>
Phone 646-558-8656 / Meeting ID: 835 4835 7175

7:00 PM

I. OPENING STATEMENT

This meeting will be held in person and online with the link provided in the agenda header. For the Public Hearings, residents can click in to participate or call in using the number provided during the Public Hearings as detailed in the agenda.

II. ROLL CALL

III. PLEDGE OF ALLEGIANCE TO THE FLAG

IV. MINUTES FROM PREVIOUS MEETINGS 5 MINS

1. To Review and Approve the Minutes of the Town Council Meeting on July 5, 2022.

V. PUBLIC COMMENTS OF NON-AGENDA ITEMS (LIMIT 3 MINS PER PERSON) 10 MINS

Comments are intended for information sharing, not discussion. Comments in excess of three minutes are welcome at the end of the agenda prior to adjournment. Call 646-558-8656 / Meeting ID: 835 4835 7175

VI. ADJUSTMENTS TO THE AGENDA 5 MINS

VII. PUBLIC HEARING(S) 7:20PM

1. First Reading/Public Hearing - To Review and Act Upon Setting a Second Reading/Public Hearing on September 6, 2022 to consider a new Short-Term Rental Ordinance (Chapter 390) which requires all short-term overnight rental accommodations in Gray to register each rental unit and pay an administrative processing fee. **5 MINS**

Proposed motion:

Ordered, the Gray Town Council approves a Second Reading/Public Hearing on September 6, 2022 to consider adopting a new Short-Term Rental Ordinance (Chapter 390). 10 MINS

VIII. ACTION ITEMS 7:35PM

1. To Review and Approve the Lease Purchase of John Deere 85 G excavator with related equipment and accessories in the amount of \$156,000. 10 MINS

Proposed motion:

Ordered, the Gray Town Council approves the Lease Purchase of John Deere 85 G excavator with related equipment and accessories in the amount of \$156,000.

2. To Review and Approve the Contract to Purchase road salt from Morton Salt for the price of \$68.27/ton for straight salt and \$98.27/ton for treated salt. 5 MINS

Proposed motion:

Ordered, the Gray Town Council awards the contract to purchase road salt from Morton Salt for the price of \$68.27/ton for straight salt and \$98.27/ton for treated salt.

3. To Review and Approve the Contract to Purchase a Generator for the Gray Public Library from _____ in the amount of _____. 10 MINS

Proposed motion:

Ordered, the Gray Town Council approves the contract to purchase a 100kw 400amp Single Phase LP Generator from _____ in the amount of _____.

4. To Review and Approve the Contract to Purchase an LED sign and sign skin from _____ in the amount of _____. 10 MINS

Proposed motion:

Ordered, the Gray Town Council approves the contract to purchase an LED sign and sign skin from _____ in the amount of _____.

5. To Review and Approve the Design of the Village Green Pocket Park welcome sign. 5 MINS

Proposed motion:

Ordered, the Gray Town Council approves the design of the Village Green Pocket Park welcome sign.

6. To Review and Act Upon Approving the Election of Nathaniel Rudy and _____ to MMA's Legislative Policy Committee. 5 MINS

Proposed motion:

Ordered, the Gray Town Council votes to elect Nathaniel Rudy and _____ to MMA's Legislative Policy Committee.

7. To Review and Act Upon Approving the Appointment of Jonathan Hartt as Acting Town Manager when Town Manager Nathaniel Rudy is unavailable. 5 MINS

Proposed motion:

Ordered, the Gray Town Council appoints Jonathan Hartt to serve as Acting Town Manager when Nathaniel Rudy is unavailable to serve as Town Manager, effective June 30, 2022.

- IX. REPORT FROM THE COUNCIL CHAIR 5 MINS - 8:25PM**
- X. REPORT FROM THE TOWN MANAGER 5 MINS**
- XI. COMMITTEE REPORTS 5 MINS**
- XII. COUNCIL CORRESPONDENCE/ACTIVITIES 10 MINS**
- XIII. ADJOURNMENT 8:50PM**

** The Town of Gray is an equal opportunity employer and complies with all applicable equal access to public accommodations law. If you are planning to attend a Town Council or Town committee or board meeting and need assistance with a physical disability, please contact the Town Manager's office at least 48 hours in advance of the meeting to have the Town assist you. 657-3339. TTY 657-3931.*

TOWN OF GRAY
GRAY TOWN COUNCIL MINUTES – JULY 5, 2022

Gray Town Council Regular Meeting	Henry Pennell Municipal Complex 24 Main Street, Gray, ME 04039	7:00 PM
--------------------------------------	---	---------

I. OPENING STATEMENT: This was conducted as a hybrid meeting - via “Zoom” and in-person.

II. ROLL CALL:

Attendee Name	Title	Status
Sandra Carder	Councilor - Chair	Present – In Person
Michael Curtis	Councilor	Present – In Person
Dan Maguire	Councilor	Present – In-Person
Krista Chappell	Councilor – Vice Chair	Present – In-Person
Martin Meaney	Councilor	Present – In Person
Jonathan Hart	Director of Human Resources/Acting Town Manager	Present – In-Person

III. PLEDGE OF ALLEGIANCE TO THE FLAG:

IV. MINUTES FROM PREVIOUS MEETINGS: There were some edits made to this set of meeting minutes. All edits will be forwarded to Cynthia Schaeffer in the Town Clerk’s Office.

1. To Review and Approve the Minutes of the Town Council Meeting on June 21, 2022.

MOTION: *by Martin Meaney, seconded by Krista Chappell, to approve the Town Council meeting minutes for June 21, 2022.*

VOTED: *5-0 (Passed).*

V. PUBLIC COMMENTS OF NON-AGENDA ITEMS (LIMIT 3 MINS PER PERSON). Public Comment was opened at 7:04 pm. There being no Public Comment, Public Comment was closed on Non-Agenda Items at 7:04 pm.

VI. ADJUSTMENTS TO THE AGENDA. Sandra asked the Council to suspend the rules to add to Agenda Item VII. Action Items, Item 7.a. 2022 Police Interceptor Utility Bid for Command Vehicle. This was submitted, but inadvertently not added to the Agenda. The following motion was made.

MOTION: *by Krista Chappell, seconded by Michael Curtis, to suspend the Council rules to add to Agenda Item VII. Action Items, Item 7a. 2022 Police Interceptor Utility Bid for Command Vehicle.*

VOTED: *5-0 (Passed).*

VII. ACTION ITEMS:

1. To Remove from the Table the Proposed FY2023 Fee Schedule. The following motion was made.

MOTION: *by Michael Curtis, seconded by Martin Meaney, to remove from the Table the Proposed FY2023 Fee Schedule.*

VOTED: *5-0 (Passed).*

2. To Review and Approve the Proposed FY2023 Fee Schedule. Sandra said the new Fee Schedule was included in the packet beginning with Page 21. The Fee Schedule shows the existing fee and a column that shows proposed changes. In the packet on Page 21, one item was moved from Code Enforcement. There were no changes made on Page 22.

On Page 23 were pre-approved changes that Josh Tiffany, the Library Director, brought to eliminate his overdue fees and restructure the actual late fees (return fees). Dan questioned the three at the bottom (in red) that were increased – 14 days past due, per incident. He said he was not sure what those were. Sandra said that is the actual way they decided to replace all the other fees. Krista, who was on the Library Trustee Committee at that time, explained that you are allowed to be late up to 14 days. Once 14 days kicks in on your account, you will have a fee for both the items – the replacement cost for the item, plus a \$3.00 fee. If you return the book within the 45 days, the fee for the book is removed, but the \$3.00 fee stands. Sandra said it is really an

administrative fee for tracking the late book, whether it is returned or not. If they never return it, they are responsible for the cost of the book.

Page 24, were Rescue Fees. At the time, these fees were questioned whether there should be an analysis done on whether or not the Town was in-line with similar towns for charging the going rate. This research was done. Peter Holmquist, from Gray Fire Rescue, was available on "Zoom." Krista requested that the acronyms be spelled out for both ALS and BLS. Peter explained the difference between ALS and BLS as a basic rate, which is based on the license level of the provider. ALS is Advanced Life Support (medical procedures and medications) and BLS is Basic Level Services, which is a lower rate charged by a provider. Advanced Life Services (ALS) is broken down into two levels on the amount of interventions and medications that are given. Krista then asked if the Town is charging rescue fees directly to people who need these services or does the Town go through their insurance companies. Peter said all billing is done by an outside billing service and it is all billed through insurance through Maine Care, Medicaid, whatever their coverage is. Sandra stated that once that billing is done, it is then billed to the patient, as is standard for all medical insurances. Dan said he was curious as to what communities were looking at when they came up with the numbers. He said he would like a list of what other communities were looked at when these numbers were derived. Peter said they went with surrounding mutual aid towns. Dan agreed that all acronyms need to be spelled out.

Sandra proceeded to Page 25, which are the Recreation Committee Fees. These were also pulled from surrounding communities with an analysis done and a recommendation was then made. The only fee readily used is the Newbegin Gym. They found that they are 20% lower than everyone else for similar facilities. They do have to have an attendant available for when people rent. She said the expense side is growing. What was proposed was a 10% to \$5.00 this year, with another 10% increase next year. She said the Recreation Committee did approve that recommendation. This was sent to Katy in Finance on time for it to be included in the Fee Schedule, but was not included. Sandra then provided the figures and said the approval will be made that the Town Council is approving the Fee Schedule with these amendments. The figures are as follows. There are four different categories for the Gym: She listed each, as follows: Local For-Profit Organization is \$50.00/Hr. or three hours for \$105.00 – This is actual going up to \$55.00 and \$115.00; Local, Non-Profit Organization, which is \$35.00 or three hours at \$75.00. This is actual going to \$40.00 and \$85.00; Non-Local/For-Profit Organization, which is \$60.00 or three hours for \$126.00. This would be \$65.00 or three at \$140.00; and Non-Local/Non-Profit Organization is \$45.00 or three hours at \$95.00. This would be \$50.00 and \$105.00. Krista asked what does the Town charge individuals who rent the Gym? Sandra will check on this and report back. She said for-profit is for businesses. Dan stated that the Fee Schedule is a lot more convoluted than it needs to be. He said it seems complex and that it should be a simple fee for each of those items. He said it is also difficult to communicate to people. Sandra said it was very hard to do comparisons, since information with other Towns was not readily available. Dan felt this could be consolidated. Sandra will bring this up.

There were no changes on Pages 27 and 28.

On Page 32 – Planning Department – Other, there is a new fee for Contract Zone Request Substantive Revised Submittal at \$200.00 and a clarification on a title (from Plan Amendments changed to Planning Board Site Plan Review/Subdivision Plan Adjustments, per item charged). It shall be noted that Dan voted against this fee structure, due to the disagreement of changes at the Library. The following amended motion was made.

AMENDED

MOTION: *by Michael Curtis, seconded by Martin Meaney, to approve the 2023 Fee Schedule, as amended.*

VOTED: *4-1 (Passed) (Dan Maguire – Opposed).*

3. To Review and Approve the creation of a designated fund for the Emergency Contingency Fund. Sandra explained that an actual new fund will maintain those funds from one fiscal year to another. If they are unused, an actual account needs to be set up. The following motion was made.

MOTION: *by Krista Chappell, seconded by Martin Meaney, to approve the creation of a designated fund for the Emergency Contingency Fund.*

VOTED: *5-0 (Passed).*

4. To Review and Approve the creation of a designated fund for Libby Hill Trails Maintenance. This fund is similar to the prior item. The following motion was made.

MOTION: *by Krista Chappell, seconded by Dan Maguire, to approve the creation of a designated fund for Libby Hill Trails Maintenance.*

VOTED: *5-0 (Passed).*

5. To Review and Act Upon Approving the Proposal for Engineering Services for the Septic System Design and Associated Items for the Pennell Municipal Complex, as submitted by the Director of Buildings & Grounds.

Present at this meeting was Mo Russo, Director of Buildings and Grounds. Mo said the one thing to be moved is for the elimination of the Basketball Court for parking. There are already funds in the designated account. This would be the thing to be moved. He said the Town is hindered on this parcel with parking. There just isn't any parking here. With the plan to keep the Manual Arts Building and convert it for recreation use and bathroom facilities for the complex, the only place to expand parking would be to replace the Basketball Court with additional parking. It is already an impervious surface. There is some work to be done with the MDEP to verify the actual amount. He mentioned the creation of a new septic system, as well as additional parking. Sandra questioned the timing in regards to the new Basketball Courts located on the Village Gateway. She said if the Town did the engineering and changed it into a parking lot and something happens with the Pennell septic, sooner than the Town

expects, would the Town be able to keep the Basketball Court here. Mo explained that the parking lot takes more engineering than the Basketball Court. After the Village Visioning, if that does not seem viable to the community, the Town can scrap the idea of putting a parking lot there and keep the basketball court. He said there was so soil engineering done previously on the Basketball Court to determine the base. The Basketball Court is a complete tear up and rebuild. Sandra said an analysis and planning will need to be done and, hopefully, the Town will replace it or relocate it, rather than just rip it up. Krista referred to in the packet on Page 35, Item 10, where it states that Gorrill-Palmer is not including a design of the irrigation system or design of the anticipated underground propane storage tank system. She felt these were a couple of key elements that were to be worked on. She asked why they are not in this engineering process. Mo said that with the irrigation system, they are only looking to extend the water from the hydrant currently out there. The installed will be of a blow off value, which allows the use of it in the wintertime. It does not freeze. In the event that they want to add irrigation, that water is already there and the parking lot would not need to be torn back up. This allows them to access an 1-1/2 line to be able to spread water quickly. Filling in the skating rink is a big thing. He said the propane storage, they will just mark where they will put them. There is no real engineering involved in that. The installer will plot where they want to put it. Dan asked, besides aesthetics, what is driving the underground propane storage? Mo responded that they are limited as to how much propane they can have at Newbegin. He said that there is no place to put tanks above ground. He said they are limited to four, 125-gallon tanks. The propane supplier delivers weekly as they need. If they miss it by a day, they usually run out. This would allow them to put in two, underground tanks to service both the current maintenance building and the gym from one location. This would be two, 1,000-gallon tanks. Krista said there is a safety issue in front of the propane tanks and to put them underground. Sandra said the budgeted amount is limited to \$50,000. Mo said the proposal came in at \$49,600 with an anticipated \$150.00 reimbursable. Dan stated that Gorrill-Palmer is the engineer that the Town uses. He asked, is there ever a time that the Town will do an RFP for engineering services? Sandra said that this really needs to be tied to the fiscal year because this was based on their contract with them this year. She said this will be ready going into the December cycle. She said it is prudent for every municipality to RFP every 3-5 years for professional services. The following motion was made.

MOTION: *by Dan Maguire, seconded by Martin Meaney, to accept Gorrill-Palmer's Proposal for Engineering Services for the Septic System Design and Associated Items for the Pennell Municipal Complex, as submitted by the Director of Buildings & Grounds, not to exceed \$50,000.*

VOTED: *5-0 (Passed).*

6. To Review and Authorize the Boat Ramp Grant Application, as submitted by the Director of Buildings and Grounds.

Present at this meeting was Mo Russo, Director of Buildings and Grounds, who explained the process and grant. There is a boating assistance fund for the creation or replacement of boating facilities within the State that are open to the public. Last year the Town had applied, but was not awarded one. This is for the replacement of the boat ramp at Wilkies Beach on Crystal Lake. The ramp would be the same width at ten feet and slightly longer to allow for the lower water use of the ramp. He said the State pays 75 percent of the cost and the Town pays the other 25 percent. He went on to say that there are a number of municipalities and organizations that apply for these grants. Sandra asked Mo if he had received any feedback from them why this Town was not picked. He said he did reach out and heard that it was the Town's ADA accessibility to the water with a dock. Krista asked Mo if this is something the Town could explore as a possibility in the Town's application. Mo responded that you kind of need to estimate what the project is going to cost and where you are going to land. Mo said the project would cost \$70,000, which was guidance they received from the State. He said a dock or other things could be added to help with the application. Krista commented that this would make the Town's application stronger, but also would be something worthwhile for the residents. Sandra asked what is the timing of grant? Mo responded that it is due by July 21, 2022. The decision for the awarding of grants is done by the end of August. There are two years to expend the funds. Mo said we would be really close to try to get anybody to do it this fall. Sandra said it does make sense to add additional items and if the Town received the money, but the grant did not cover the additional items for those, this could be taken up in the next fiscal budget to see if the Town can come up with the additional funds to make that happen. Sandra stated that the Town has the match of 25% for the \$70,000 in this year's budget. If the Town goes above the \$70,000, the Town would need to make up the difference. Mo stated that this is not tied to the actual budget. Mo stated that there is actually quite a bit of space between the current ramp and the swim area. Mo stated that the ramp itself requires MDEP approval. The limit to how much dock would require MDEP approval and would be determined by how much will be done on the shore side. He said a lot of docks are removable or you can land them on the shore with very minimal impact. Mo said currently that whole area is hard-packed. A path could be stone dusted. He said there is enough room to get a path and dock with very minimal disturbance. Sandra said if the ADA piece is not added, than the Town is in the same boat as last year. Dan said he was okay if the scope of the grant is expanded. He said he just wants to make sure that the Town does what it says they will do. Mo said the only sign off that is needed is from the Maine State Historic Preservation, of which they have. Mo said, in the grant, the Town can state that the intention is to add more ADA accessibility, contingent upon Local and State approval. The deadline is in two weeks. The following motion was made.

MOTION: *by Martin Meaney, seconded by Michael Curtis, to authorize the Town Manager to apply, on behalf of the Town of Gray, for state financing assistance under the provisions of the Boating Facility Fund, Title 12 MRS §1896 and 1899 for the reconstruction of Wilkies Beach Boat Ramp Replacement on Crystal Lake and further authorize the Town Manager to enter into the Boating Facility Fund Project Agreement with the State subsequent to state approval of the project. Furthermore, it is understood that if Town tax appropriations are being used for all or part of the local share of the project cost, the Town must raise the funds through Town*

Meeting or Council action. The Town is obligated to pay all costs of the project "up-front." Therefore, there may be the need to authorize the borrowing of funds which will be repaid by state reimbursement.

VOTED: 5-0 (Passed).

7. To Authorize New England Mountain Bike Association to perform trail work on Libby Hill, as recommended by the Director of Buildings and Grounds. This was included in the packet on Page 56. Present at this meeting was Mo Russo, Director of Buildings and Grounds. He said New England Mountain Bike Association has received a grant to perform trail work throughout the State of Maine and have rented a machine to assist in recreation areas with their mountain bike trails. Libby Hill is one of the areas they would like to do some work. They have a small excavator and will be smoothing and redefining some of the wider cross country ski trails that have steep banks to them and some mountain bike trails on the other side of Libby Hill that they will be cleaning up. The following motion was made.

MOTION: *by Krista Chappell, seconded by Martin Meaney, to authorize New England Mountain Bike Association to perform trail work on Libby Hill for the duration of 2022, as recommended by the Director of Buildings and Grounds.*

VOTED: 5-0 (Passed).

7.a. To Review and Approve the Public Safety Departments Purchase of a 2022 Ford Interceptor Command Vehicle, as specified in Bid Proposal, not to exceed \$50,000, to be used as the Command Response Vehicle for the Assistant Chief. This item was included in the packet, as Pages 12-20. Present at this meeting was Peter Holmquist, Gray Fire Rescue. Peter said that this is a new vehicle. The budgeted amount was \$50,000 and that includes the radio upgrades. Sandra said that this will be added to the Public Safety Vehicles on the CIP. This command vehicle is a 2021-2022. Peter said that they cut the Town a good deal. It is police road-ready. It is just labor, less than \$500. Even with the lettering, they did not go over the budgeted amount and will not to exceed \$50,000. The following amended motion was made.

AMENDED

MOTION: *by Krista Chappell, seconded by Michael Curtis, to approve the Public Safety Departments purchase of a 2022 Ford Interceptor Command Vehicle, as specified in Bid Proposal, not to exceed \$50,000.*

VOTED: 5-0 (Passed).

8. To Review and Act Upon Approving the Appointment of Anne Gass as a regular member of the Open Space Committee with a term expiring on August 31, 2024. The following motion was made.

MOTION: *by Martin Meaney, seconded by Michael Curtis, to appoint Anne Gass as a regular member of the Open Space Committee with a term expiring on August 31, 2024.*

VOTED: 5-0 (Passed).

9. To Review and Act Upon Approving the Appointment of Melinda Shehee as a regular member of the Planning Board with a term expiring on August 31, 2023. Sandra stated that she has experience in other towns and legal experience. The following motion was made.

MOTION: *by Dan Maguire, seconded by Michael Curtis, to appoint Melinda Shehee as a regular member of the Planning Board with a term expiring on August 31, 2023.*

VOTED: 5-0 (Passed).

10. To Review and Act Upon Approving the Appointment of Georgia Marie Woodbury as a regular member of the Zoning Board of Appeals with a term expiring on August 31, 2023. Dan commented that she is a person of great experience. The following motion was made.

MOTION: *by Martin Meaney, seconded by Dan Maguire, to appoint Georgia Marie Woodbury as a regular member of the Zoning Board of Appeals with a term expiring on August 31, 2023.*

VOTED: 5-0 (Passed).

11. To Review and Act Upon Approving the Appointments of Lacy Antonson and Lisa Lehne-Gilmore as Comprehensive Plan Coordinators. Both these appointments can be done together in one motion as there are no terms. Sandra asked that both Dan and Krista set up a meeting with them to go over the plan and help get them started and be the liaisons. The following motion was made.

MOTION: *by Martin Meaney, seconded by Michael Curtis, to appoint both Lacy Antonson and Lisa Lehne-Gilmore as Comprehensive Plan Coordinators.*

VOTED: 5-0 (Passed).

12. To Review and Act Upon Approving the Appointment of Julie Quinn as an alternate member of the Wild Blueberry Festival Committee with a term expiring on August 31, 2024. Before the motion was made, Sandra stated that Lisa Lehne-Gilmore's name got moved forward and that it be changed to Julie Quinn. The following motion was made.

MOTION: *by Martin Meaney, seconded by Dan Maguire, to appoint Julie Quinn as an alternate member of the Wild Blueberry Festival Committee with a term expiring on August 31, 2024.*

VOTED: 5-0 (Passed).

VIII. REPORT FROM THE COUNCIL CHAIR. Sandra stated that Town Manager Nate Rudy is out of the office until July 25, 2022. Jonathan Hartt is the Acting Town Manager in his absence and will provide the Town Manager report. However

in his absence, she covered a couple of items, as follows:

Assessed Valuations/MIL Rate: Lauren Asselin, Assessor, has completed the State mandated updates to property valuations throughout the Town. This was triggered when the State audit resulted in Gray being at only 88% of market value. She said we are all aware of the sharp increases in home valuations in the last year. Lauren, who is on vacation this week, has confirmed with the State that the Town is now back at 100%, which allows the Town to provide the full homestead and veterans exemptions to those who qualify. Lauren is proposing a MIL rate of 13.95, which is an expected reduction. Sandra said first, please note that Nate Rudy mentioned a different number in his attached report, but that changed, due to the planned CIP payment that the Town Council agreed with from the overlay fund. Dan Maguire asked that this get changed in the packet. Sandra said this will be adjusted. She then said, second, for those watching this meeting, once again, the reduction in the MIL rate is not going to necessarily equate to an automatic reduction in taxes, as the reason it is going down is because valuations are going up. She said we all remember the full re-valuation that was done a few years back. Generally, the rule of thumb is 1/3 of property owners will see an increase, 1/3 a decrease and 1/3 remain the same. It will not be as widespread as a full re-valuation. It is a smaller modification. The budget itself does not impact the taxes this year, it is the re-valuation that is driving the changes. So, for example, newer homes may have seen a higher valuation increase than existing homes (in town for 10-15 years), as the depreciation is not fully realized on new homes. Dan said we are seeing changes in the future earlier than in the past. He said the timing of this is beyond our control. He said the market drives that. He said depending on the market and that this could happen again next year. This is not on an annual or regular cycle. He said what needs to be put in the Town's budgeting process is a discussion at the beginning of the process of what is happening to the real estate market and that it is likely to have an impact on the Town's work as the Council gets to the end of the process. He would like to see this question added to the beginning of the Town's budgeting process. Sandra commented that Gray's re-valuation was not done for 15 years. They are trying to do it every 10 years now for less of an impact.

Sandra shared the worksheet Lauren provided with the Council. The 13.95 MIL rate results in an overlay of \$461,563. She said the Council had agreed to move \$400,000 of that into the CIP fund. That leaves \$61,563 for abatements. Lauren pulled the amounts she has needed for the last several years and highest amount was \$36,000 in the year following the re-valuation. Sandra said when an abatement happens, the Town has already committed the taxes, this fund is used to pay the difference between what was supposed to be paid by us and what is actually paid by us. Lauren does not expect to need that much this year, but having a cushion is a good idea. Any monies leftover in the overlay will automatically go into the general fund at the end of the fiscal year. Based on some preliminary numbers, the average tax swing will be around \$225 – that is an average so some people will see lower amounts, some higher and those are only on those accounts that are seeing increases/decreases. Some people may not see any change. She will not be committing taxes for a little bit so if there are questions, they can be send them to her and she can provide responses.

Tax Bill Insert (Flyer): She provided the draft document. This will go to the printers once any feedback is finalized. Dan Maguire suggested, as part of a rental notice, in the second paragraph where it starts with "*Registrations of Short-Term Rentals (STR's) will be required by the Town of Gray on an annual basis knowing the number and nature of STR's in Town will allow the Council to make an informed decision regarding any additional regulation, they may choose to impose in the future.*" He said this brings a lot of emotion to the table for a lot of groups of people. This was not a purposeful choice of words. He said it would be more accurate to say, "*The Council will be able to make informed decisions regarding any future regulations.*" Then, strike the rest of that sentence. Doug Webster said that one of the overriding messages that they are hoping to deliver in regards to STR's is that there may be a registration process coming. It is not going to lock people in if there are future Performance Standards. Any subsequent Ordinance will be applicable to current future short-term rentals operation with no exclusions for existing operations. Sandra will send these changes to Lauren with a copy to Dan Maguire. Sandra stated that the registration is to just get a handle on what there is in Gray and what types. Dan said it is definitely an improvement.

Weight Limit Short Shaker: She followed up with Dale Doughty regarding the Ordinance wording that MDOT was going to provide, and he said he believes they have identified some wording and will be sending it along.

Village Charrette: She said this was discussed earlier in the Workshop, but to remind all watching, the July 27-30, 2022 event will now take place at the Pennell Building vs. the Parish House, due to air conditioning. The room is ADA accessible via the elevator. The Kick-Off meeting had a good crowd and the activities were really easy and fun. Those in attendance provided some good initial feedback and ideas. She said the hope is that more people will come out to share their vision of the Village. There is also a Website for those who cannot physically attend. The Council will have no additional meetings in July, due to the Charrette.

Staff Training: She said she attended the Staff Training Day to provide employees with information about the Village Charrette and to seek their input and assistance in getting the word out. Several provided immediate ideas and thoughts – including restricting large vehicles on some of the roads, improving the signage, making Brown a one-way and reducing speeds. She shared the weight limit and route designation work that is underway with the MDOT. It was interesting as she was told it is a common comment from those registering large commercial vehicles that they were unaware they should be using the bypass and did not know it was there, as they were new to the route & their GPS did not take them that way! She said one of the Clerk's will need to explain this at one of the MDOT meetings.

LH Shadow work: She said she met with Mo and have started the Policy & Procedures Manual for Libby Hill (LH), as part of the shadowing work as winter grooming is done, Longest Day 5K is awaiting a debrief meeting, and mowing/summer maintenance is currently underway.

Volunteer awards: She reported that she is finalizing the scripts for these awards and will send them to the Council in an e-mail. She said the assignments need to be worked on as to who will present each award. There is a list of presentations to do. They will

know ahead of time and that they were selected and they will need to RSVP so that it is known if they are coming or not.

Annual Reports: A reminder that the Council needs to help committees complete these by end of month or shortly thereafter. This is an annual report summary.

IX. REPORT FROM THE TOWN MANAGER. As Acting Town Manager, Jonathan Hartt provided the following. The Town Manager's Report to the Town Council (06/15/2022 – 06/30/2022) was included in the packet. Jonathan mentioned the Maine Workforce Development Compact. He is recommending that the Town join that in order to enable access to professional development funds for Staff. He said there is no cost to the Town to do so. Staff would have access to \$1,200 per front line worker (all Staff) through 2022; \$600 in 2023 and 2024 to attend courses at Maine's Community Colleges or through a Third-Party Vendor. He said he will be the workplace liaison for that program and will work with the Community College, if Staff attends any courses. All municipal employees are eligible. The Workforce Compact is sponsored by The Harold Alfond Center for Advancement of Maine's Workforce.

He reported that the Town's Attorney has drafted a Memorandum of Understanding (MOU), which was included in the packet on the storage and use of the antique fire vehicle between the Town of Gray, the Gray Historical Society, Inc., and the Gray Fire/Rescue Association, Inc.

Also, included in the packet was a draft letter of support for the Coalition Against Bigger Trucks (CABT) from the Town of Gray to Gray's federal delegation. Sandra stated she was 100% behind this.

He went on to report that Nate Rudy is recommending that Finance Director Katie Johnston serve as Gray's EcoMaine representative. There were no objections from the Town Council on her appointment.

He said a question was added to the Boards & Committees Application to include mention of how they heard of the opening. He said this is so information can be gathered to make sure the Town is doing everything to promote volunteer opportunities in the Town. The Council agreed that this was a great addition.

Sandra Carder thanked Josh Tiffany, the Library Director and his limited Staff regarding bad things happening at once and that there was minimal impact to the public (due to short-staffing). She said there is really a great team over there.

X. COMMITTEE REPORTS.

Krista Chappell:

The **Resiliency Committee** met on June 24, 2022. They elected Jayne Chandler as Chair and confirmed Ellie Steele as Secretary. The 207 Permaculture led a successful four "G's" discussion, those being: Gains, Groans, Give, and Guidelines on how the committee was feeling in reference to the upcoming work that they will be doing with the 207 Permaculture to join the community resiliency partnership. They also reviewed highlights and priorities that the committee worked on the last year. She will be drafting the annual report for the committee to review at their next meeting on July 22, 2022.

The **OAC** met on June 23, 2022. She was absent due to an existing conflict that had occurred that week. She went over the notes that Doug Webster had provided to her. She said they discussed Short-Term Rentals (STR's). They used the current draft of the Ordinance that the Town Council reviewed at their Workshop on May 19, 2022. She said Doug Webster summarized the Town Council input from the Town Council Workshop. As part of their discussion they noted that there are many lakefront properties that are being converted to year-round properties. Increased use of these properties results in more potential impacts, such as wastewater. The consensus is to wait on adopting an Ordinance. They recognize that the Council and the Town Manager would like to see at least a basic Ordinance on the books. The OAC has presented three options: 1. To not have an Ordinance on STR's; 2. A basic Ordinance with registration only, or 3. An Ordinance with registration and standards. Given the Town Council input and wanting an Ordinance on the books, the OAC advocates: 1. A basic Ordinance requiring registration and 2. With the burden on the owner of a STR for compliance with applicable permits and standards. The current anticipated timeline: First Reading at the Town Council's August 2, 2022 regular meeting.

The **GPCOG Executive Committee** will be resuming meetings on September 20, 2022.

She also said, as a note, that she e-mailed members of the Library Trustees and the CEDC that Michael Curtis is now their liaison now and gave them reminders about their Annual Reports and committee members that need to re-apply.

Dan Maguire: The **Planning Board** does have a meeting scheduled for July 14, 2022 at 7:00 pm.

Michael Curtis: The CEDC will be meeting on July 20, 2022 and the **Community TV Committee** will be meeting on July 27, 2022.

Martin Meaney: The **Wild Blueberry Festival Committee** met on June 22, 2022 with a quorum. They discussed some Logistical issues, such as needing more volunteers, arrival times, parking, band stand, wagon ride, tee shirts for sale, photography, and the various programs. They qualified for a \$2,500 grant, which was approved. They will be receiving after July 1, 2022. He said more food trucks are needed. The lawn signs advertising the event can go out three weeks before. They will be meeting next on July 13, 2022, with subsequent meetings on July 27, 2022, August 3, 2022, and August 10, 2022.

The **Finance Committee** met on June 30, 2022 and had a quorum. Charlie announced that this was his last meeting and that it was the end of his term. He reported expenses are at 76.28 percent of the total year and revenues after 11 months, are at 102 percent – so there will be a surplus. He said they are looking for volunteers to replace Charlie. They will meet next on September 29, 2022 at 4:00 pm.

The **ZBA** met on June 22, 2022. There were two issues. 1. An Undue Hardship for 27 Qualey Road. The variance was granted. 2. An Administrative Appeal for 71 Portland Road. They had issues with not having a recycling license, an unapproved road on

the property, no junkyard license, and encroaching on a right-of-way (ROW) on Route 100. Sandra said it was a very long meeting, but encouraged the Board Members to listen to the recording. The last item was a split decision. The ZBA need's a couple more volunteers. She said it is a critical role that the ZBA provides. Doug Webster thanked Scott Dvorak (former CEO) for coming back and signing the Notice of Decision (NOD).

Sandra Carder:

DMS: The DMS held a work session at the Schoolhouse on June 22, 2022. Unfortunately, the stain used on the floor is not working well – the wood is simply not absorbing it. Mo will need to remove the excess stain and work on a solution to seal the floor. That required that their second work session in June be cancelled. They hope to have a work session next week. The next official meeting is July 18, 2022 at 4:00 pm, which they also hope to hold at the Schoolhouse.

Open Space: Open Space will be meeting tomorrow night at 6:00 pm.

Rec Comm: Their next meeting is Monday, July 11, 2022 at 6:00 pm.

XI. COUNCIL CORRESPONDENCE/ACTIVITIES.

Krista Chappell:

Replied to the Crystal Lake Association (Cheryl Welch) regarding the July 9, 2022 meeting. She reported having a conflict and cannot attend. She will reply again to her.

She informed the CEBE, GPCOG, CCSWCD through e-mail and their contacts there of CRP service provider that they committed to was with 207 Permaculture and thanked them for their engagement.

She notified Rachel of Rumson of the selection as service provider.

She e-mailed Jason Wilson RE: Cleantap Energy Solar Array proposal.

She attended the Village Visioning kick-off on June 27, 2022.

Dan Maguire: He said he had some of the communications that Krista did.

Michael Curtis: He had nothing further to report.

Martin Meaney:

He had a conversation with a resident at the Transfer Station about two weeks ago regarding stickers. Stickers are required on vehicles. He said it is time to have someone at the gate to monitor that.

He attended a Planning Session at the Church on June 27, 2022.

He will be attending the July 9, 2022 meeting at the Crystal Lake Association.

Sandra Carder:

She reported that she received a follow up from Deer Acres, as they are holding their Annual Road Association meeting. She advised that the Council would not be looping back to regular Workshops until September 2022 and cannot confirm the Agendas until they get closer to that time.

She received a complaint about debris/vehicles blocking or on the cemetery property, which she referred them to Code Enforcement in Nate's absence.

She received a request for presentation space on an upcoming meeting from Senator Cathy Breen's aide to share highlights of the past Legislative session. She provided the Sept/Oct schedules. She commented that they will get back to her.

She also attended the Village Visioning and spent three hours at the Transfer Station handing out cards about the Village Visioning.

XII. ADJOURNMENT. The following motion was made.

MOTION: *by Krista Chappell, seconded by Michael Curtis, to adjourn the meeting at 8:35 pm.*

VOTED: *5-0 (Passed).*

Respectfully submitted,

Doreen M. Christ
Transcriptionist/Minute Taker - Town of Gray

CHAPTER 390
SHORT-TERM RENTAL ORDINANCE
TOWN OF GRAY MAINE

Short-term Rental Ordinance Adopted September 6, 2022 / Effective Date October 6, 2022

SECTION 1 – GENERAL ADMINISTRATION

SECTION 1.1 – PURPOSE

The Town of Gray seeks to balance the desire of property owners to rent their properties to short-term tenants and the desire of residents to preserve the character of their residential neighborhoods. The purpose of this ordinance is to minimize the negative impacts of transient occupation on adjacent residents, to maintain housing availability for long-term residents and to protect the public safety of visitors and residents. This ordinance is applicable to all short-term rentals, including those existing prior to enactment of the ordinance and those that are new.

SECTION 1.2 – EFFECTIVE DATE

The effective date of this Ordinance shall be October 6, 2022.

SECTION 1.3 – APPLICABILITY

The provisions of this Ordinance shall apply to all permanent single-family, duplex, or multi-family dwellings at which one or more overnight accommodations are available to rent for a tenancy of less than thirty (30) consecutive calendar days, excluding campgrounds, motels, hotels, and bed and breakfasts. Short-term rentals may be permitted in non-permanent structures such as tents and recreational vehicles, provided that such rentals comply with the requirements of this Ordinance.

SECTION 1.4 – APPEALS

Decisions of the town staff under this ordinance shall be appealed to the Town Council within thirty (30) calendar days of the date of the decision. Appeals shall be filed with the Town Clerk and shall include a summary of the decision from which the appeal is taken and a summary of the issues for which review is sought.

SECTION 1.5 – SEVERABILITY

Should any section or provision of this Ordinance be declared by the courts to be invalid, such decision shall not invalidate any other article, section, or provision of this Ordinance.

SECTION 1.6 – CONFLICTS WITH OTHER ORDINANCES

This Ordinance shall not repeal, annul, or in any way impair or remove the necessity of compliance with any other rule, regulation, permit, or provision of law. Whenever the requirements of this Ordinance are in conflict with the requirements of any other lawfully adopted rules, regulations, Ordinances, deed restrictions, or covenants, the most restrictive shall govern.

SECTION 2 – REQUIREMENTS

SECTION 2.1 – REGISTRATION

- A. The owner(s) of the property on which the short-term rental is located must register each year with the town prior to advertising, renting or operating a short-term rental unit. Registration forms will be available via the Town website or at the Town Clerk’s office and must be

submitted to the Town Clerk, together with the registration fee, on an annual basis, due by January 2 for the current calendar year.

- B. The annual registration shall expire December 31 of each year. Registrations and accompanying fees for the next calendar year shall be accepted beginning December 1 for the subsequent year's registration.
- C. The annual registration fee will be established by order of the Town Council. The town will charge a penalty fee, not to exceed double the registration fee, for properties in violation of the STR ordinance, for those properties not registered by March of the calendar year in which the STR is operating.
- D. If more than one short-term rental unit is located on a single property, a separate registration and accompanying fee shall be paid for each individual short-term rental unit.
- E. The registration form will require property owners to submit and affirm the following information for short-term rental operation:
 - 1. location, including street address and Town of Gray assessing map/lot;
 - 2. the maximum number of people that may be staying overnight in the STR;
 - 3. if there is more than one (1) STR on one property, the number of additional STR's available for rental on the subject property;
 - 4. period of rental availability during the calendar year;
 - 5. 24/7 contact information, including a cell phone number, for the property owner(s) and/or manager for use by public safety personnel in the event of an emergency; and
 - 6. affirmation that the STR complies with applicable building and fire safety codes as well as all applicable federal, state, and local statutes, laws, ordinances, rules and regulations.

SECTION 2.2 – PERFORMANCE STANDARDS

- 1. The property owner(s) shall be responsible for complying with applicable building and fire safety codes.
- 2. The property owner(s) shall be responsible for complying with all applicable federal, state, and local statutes, laws, ordinances, rules and regulations.
- 3. The property owner(s) shall be responsible for ensuring that emergency contact information is clearly and conspicuously posted in all rental units and shall include the name(s), 24-hour phone number(s), and email address(es) of the property owner(s) and/or manager(s).
- 4. In accordance with State-mandated building and plumbing code requirements, short-term rentals in permanent structures are required to have access to adequate bathroom facilities.
- 5. Short-term rentals may be permitted in non-permanent structures such as tents and recreational vehicles, provided that the requirements of this Ordinance are met for such non-permanent structures.
- 6. The code enforcement officer is authorized to inspect the STR property upon receipt of any code violation complaint.

SECTION 2.3 –VIOLATIONS AND ENFORCEMENT

Failure to comply with any requirement of this Ordinance shall result in the issuance of a notice of violation from the code enforcement officer or other authorized official of the Town. If the violation is not addressed within the time period established in the notice of violation, the Town may bring an enforcement action in the Maine District or Superior Court. Each violation shall be subject to a minimum fine of \$100. Each day that the violation continues shall be considered a separate violation. In the event that the Town is successful in proving a violation, it shall be entitled to recover its attorney's fees and costs in bringing the enforcement action.

**TOWN OF GRAY, MAINE
IN TOWN COUNCIL**

ORDER AUTHORIZING LEASE PURCHASE OF EXCAVATOR

WHEREAS, the Town authorized an amount of \$50,000 as part of the debt service line item of the Town's capital projects for the Fiscal Year 2023 budget and the appropriation from the Capital Reserve Fund to finance the lease purchase of one new John Deere 85 G excavator with related equipment and accessories (the "Equipment") by referendum vote during a Town Meeting duly called and held on June 14, 2022;

WHEREAS, pursuant to such Town Meeting authorization, the Town desires to authorize a municipal lease purchase financing arrangement to finance the costs of the Equipment;

NOW, THEREFORE, BE IT ORDERED by the Town Council of the Town of Gray as follows:

1. Appropriation. The sum of \$54,021.91 is hereby appropriated for the first of three principal payments to be applied to the lease purchase of the Equipment.
2. Equipment Lease Purchase Agreement and related documents. For the purposes of financing the costs of acquisition of the Equipment, pursuant to the Town Charter and all amendments thereof and acts additional thereto, and all other authority thereto enabling, there is hereby authorized and approved an equipment lease purchase agreement, such lease to be in such form and contain such terms and provisions as the Town Manager may hereafter determine or authorize, with such terms and conditions, including the interest rate(s), term or maturity and other terms and conditions as set forth in the proposal from Androscoggin Bank dated July 21, 2022, and to award the equipment lease purchase agreement(s) to Androscoggin Bank (the "Lease").
3. Reimbursement. It is the intent of the Town Council that this Order shall constitute the Town's declaration of official intent within the meaning of Treasury Regulation 1.150-2 to pay, on an interim basis, costs of the Equipment, which costs the Town reasonably expects to reimburse with proceeds of the Lease to be issued in the maximum principal amount of \$156,000.
4. Tax Status. The Town covenants that it will perform all acts within its power which are or may be necessary to ensure that the interest portion of the lease payments under the Lease shall at all times be and remain exempt from federal income taxation. The Town further covenants that the Lease is hereby designated a Qualified Tax Exempt Obligation pursuant to Section 265(b) of the Internal Revenue Code.

5. Town Officials. If any of the officers or officials of the Town who have signed or sealed the Lease shall cease to be such officers or officials before the Lease so signed and sealed shall have been actually authenticated or delivered by the Town, such Lease nevertheless may be authenticated, issued, and delivered with the same force and effect as though the person or persons who signed or sealed such Lease had not ceased to be such officer or official; and also any such Lease may be signed and sealed on behalf of the Town by those persons who, at the actual date of the execution of such Lease, shall be the proper officers and officials of the Town, although at the nominal date of such Lease any such person shall not have been such officer or official.

6. Deputy Officers. If the Treasurer, Chair of the Town Council, or Clerk are for any reason unavailable to approve and execute the Lease or any of the related financing documents, the person or persons then acting in any such capacity, whether as an assistant, a deputy, or otherwise, is authorized to act for such official with the same force and effect as if such official had herself performed such act.

7. Other Actions. The Treasurer, Chair of the Town Council, Clerk and other appropriate officers of the Town are hereby authorized and empowered to do all such acts and things, and to execute, deliver, file, approve, and record all such financing documents, contracts, deeds, assignments, certificates, memoranda, abstracts, and other documents as may be necessary or advisable, with the advice of counsel for the Town, including but not limited to any certificates, bond insurance agreements, notices of sale and other documents as may be necessary or appropriate in connection with the sale of the Lease and any letter of credit agreement or liquidity facility agreement necessary to the issuance of any Lease, to carry out the provisions of this Order and the provisions set forth above in connection with the lease purchase of the Equipment, the execution, sale, and delivery by the Town of the Lease and the execution and delivery of any related financing documents.

8. Effective Date. This Order shall take effect immediately upon adoption by the Town Council.

Adopted this 2nd day of August, 2022 by the Municipal Officers of Gray, Maine:

Sandra Carder, Chair

Michael Curtis

Krista Chappell

Dan Maguire

Martin Meaney

2022 GPCOG ROAD SALT AND DE-ICING PRODUCTS BID PRICES: Sodium Chloride and De-Icing Products								
Low Bids in Yellow		NB: No Bid						
Company Name of Bidder:	Cargill Salt		Eastern Salt Company		Morton Salt		Safe Road Services	
SODIUM CHLORIDE								
	Delivered	Picked Up	Delivered	Picked Up	Delivered	Picked Up	Delivered	Picked Up
Price per ton	NB	NB	\$87.87	\$87.87	\$68.27	\$68.00	NB	NB
Stockpile location(s):			Chelsea, MA/Portland, ME/Portsmouth, NH		Portland, ME			
Anti-cake conditioner color:			Yellow		Yellow (YPS)			
Origin of salt:			Chile		Chile, South America			
Storage:			Attached qualification statement		Product is unloaded using their equipment, placed into hoppers, loaded into trucks, transported to the stockpile, and covered with a tarp			
Phone number for product orders:			855-676-9388 (dispatch)		855-665-4540		508-364-1739 (508-541-3121 fax), saferoadservices@comcast.net	
Phone number for delivery issues:			978-251-8553 or 888-846-9177 (toll free)		570-479-2336 (Deb Aten)		508-364-1739 (Kevin Barrett)	
Delivery:			Lincoln Street Materials 207-767-9800		contracted trucking			
ORGANICALLY PRE-TREATED SODIUM CHLORIDE FOR REDUCED FREEZING POINT PERFORMANCE								
	Delivered	Picked Up	Delivered	Picked Up	Delivered	Picked Up	Delivered	Picked Up
Price per ton	NB	NB	NB	NB	\$98.27	\$98.00	NB	NB
Stockpile location(s):					Newington, NH			
Anti-cake conditioner color:					Yellow (YPS)			
Origin of salt:					Chile, South America			
Storage:					Product is unloaded using their equipment, placed into hoppers, loaded into trucks, transported to the stockpile, and covered with a tarp			
Phone number for product orders:					855-665-4540			

2022 GPCOG ROAD SALT AND DE-ICING PRODUCTS BID PRICES: Sodium Chloride and De-Icing Products

Low Bids in Yellow

NB: No Bid

Company Name of Bidder:	Cargill Salt		Eastern Salt Company		Morton Salt		Safe Road Services	
Phone number for delivery issues:					570-479-2336 (Deb Aten)			
Delivery:					contracted trucking			
CALCIUM CHLORIDE LIQUID (30%)								
<i>Please indicate available units:</i>	Delivered	Picked Up	Delivered	Picked Up	Delivered	Picked Up	Delivered	Picked Up
1	NB	NB	NB	NB	NB	NB	NB	NB
Phone number for product orders:								
CALCIUM CHLORIDE LIQUID (32%)								
<i>Please indicate available units:</i>	Delivered	Picked Up	Delivered	Picked Up	Delivered	Picked Up	Delivered	Picked Up
1 2,000-2,999 gallons	NB	NB	NB	NB	NB	NB	NB	NB
2 3,000+ gallons	NB	NB	NB	NB	NB	NB	NB	NB
3								
Phone number for product orders:								
CALCIUM CHLORIDE LIQUID (34%)								
<i>Please indicate available units:</i>	Delivered	Picked Up	Delivered	Picked Up	Delivered	Picked Up	Delivered	Picked Up
1	NB	NB	NB	NB	NB	NB	NB	NB
Phone number for product orders:								
CALCIUM CHLORIDE FLAKES								
<i>Please indicate available units:</i>	Delivered	Picked Up	Delivered	Picked Up	Delivered	Picked Up	Delivered	Picked Up
1 50# bag (55 bag lots)	NB	NB	NB	NB	NB	NB	NB	NB
2								
3								
Phone number for product orders:								

2022 GPCOG ROAD SALT AND DE-ICING PRODUCTS BID PRICES: Sodium Chloride and De-Icing Products

Low Bids in Yellow

NB: No Bid

Company Name of Bidder:	Cargill Salt		Eastern Salt Company		Morton Salt		Safe Road Services	
CALCIUM CHLORIDE WITH ORGANIC-BASED PERFORMANCE ENHANCER (OBPE) (LIQUID)								
<i>Please indicate available units:</i>	Delivered	Picked Up	Delivered	Picked Up	Delivered	Picked Up	SAFE MELT™ Delivered (/gal)	Picked Up
1 4,500 gal (full trailer)	NB	NB	NB	NB	NB	NB	\$1.46	NB
2 2,000-4,499 gal							\$1.56	NB
Phone number for product orders:							508-364-1739	
MAGNESIUM CHLORIDE WITH ORGANIC-BASED PERFORMANCE ENHANCER (OBPE) (FLAKES)								
<i>Please indicate available units:</i>	Delivered	Picked Up	Delivered	Picked Up	Delivered	Picked Up	Delivered	Picked Up
1 50# bag	NB	NB	NB	NB	NB	NB	NB	NB
2 100# bag	NB	NB	NB	NB	NB	NB	NB	NB
3 1,800# tote	NB	NB	NB	NB	NB	NB	NB	NB
Phone number for product orders:								
LIQUID BRINE								
<i>Please indicate available units:</i>	Delivered	Picked Up	Delivered	Picked Up	Delivered	Picked Up	Delivered	Picked Up
1	NB	NB	NB	NB	NB	NB	NB	NB
2								
3								
Phone number for product orders:								
ICE B'GONE LIQUID DE-ICER								
<i>Please indicate available units:</i>	Delivered	Picked Up	Delivered	Picked Up	Delivered	Picked Up	Delivered	Picked Up
1	NB	NB	NB	NB	NB	NB	NB	NB
2								
3								
Phone number for product orders:								

2022 GPCOG ROAD SALT AND DE-ICING PRODUCTS BID PRICES: Sodium Chloride and De-Icing Products								
Low Bids in Yellow		NB: No Bid						
Company Name of Bidder:	Cargill Salt		Eastern Salt Company		Morton Salt		Safe Road Services	
CALCIUM CHLORIDE WITH ORGANIC-BASED PERFORMANCE ENHANCER (OBPE) (LIQUID)								
<i>Please indicate available units:</i>	Delivered	Picked Up	Delivered	Picked Up	Delivered	Picked Up	Delivered	Picked Up
1 2,000-4,499 gallons	NB	NB	NB	NB	NB	NB	NB	NB
2 4,500 gallons (full trailer)	NB	NB	NB	NB	NB	NB	NB	NB
3								
Phone number for product orders:								



TOWN OF GRAY

Henry Pennell Municipal Complex
22B Main St, Gray Maine 04039
www.graymaine.org

DEPARTMENT OF BUILDINGS AND
GROUNDS

Mo Russo III, Director
mrusso@graymaine.org
207-657-3339 ext.131

MEMO

To: Nate Rudy, Town Manager
Gray Town Council

From: Mo Russo, Director of Buildings and Grounds

Date: July 27, 2022

Re: Library Generator

A Request for Proposal was issued for a 100kw Single Phase 400amp LP Generator with a 400-amp Service Rated Automatic Transfer Switch. Certified Letters with Return Receipt were sent to: Electrical Systems of Maine, Generators of Maine, Gowen Inc, Mid Maine Generator, and Power Products LLC. The RFP was posted on the Town's website as well. Bids were due on July 21st by noon, they were read aloud.

The Town received five bids total. Electrical Systems of Maine bid two options, both 100kw Generac units, bid 1: \$32,200 for a Protector Series estimated delivery 67 weeks, bid 2: \$40,300 for an Industrial Series estimated delivery 32-38 weeks. Gowen Inc. bid a 100kw Kohler for \$55,650 with no estimated delivery. Mid Maine Generator bid a 100kw Kohler for \$36,273 with a 42-week estimated delivery. Power Products LLC bid a 100kw Kohler for \$42,725 with an estimated 48–52-week delivery.

Although Electrical Systems of Maine is the low bid at \$32,200, the anticipated delivery at 67 weeks from the time of order falls outside the parameters for the grant which closes on 5/31/2023. In verifying the delivery window with Mid Maine Generator, I was informed that Kohler had issued a price increase for the specified equipment in the amount of \$3,825. It is my recommendation is to award the bid to Mid Maine Generator as they are the second lowest bid at \$40,098 and the generator delivered in the timeframe needed

This project is funded by a FEMA grant with a Town match. At the time of application, I estimated the project to cost \$71,500. After the submittal costs continued to rise for materials and equipment. The Towns budgeted portion increased to \$42,000 to cover the anticipated increases.



Electrical Systems
of Maine, Inc.



Date: 07/18/22

To Mo Russo,

Electrical Systems of Maine is pleased to provide this proposal to supply a 100kw propane fueled generator system to the Town of Gray.

Electrical Systems of Maine is an electrical contractor based in Auburn, Maine, we have been in business for 36 years and is a second-generation family run Maine business. We currently employ 48 electricians, project managers, and office staff. We are a one stop shop for the design, installation, service, warranty work of Generac generator systems.

Electrical Systems of Maine specializes in the specification, sizing and installation of residential, commercial, and industrial generators. We are one of the largest dealers of Generac generators in the State of Maine. We currently hold the Premier dealer status with Generac, last year we installed over 325 residential generators and 25 commercial and industrial generators similar to the system requested by the Town of Gray.

Electrical Systems of Maine appreciates the opportunity to supply the generator equipment for this project.

I have provided you two options.

1. Option 1 – light commercial option
2. Option 2 – Specification (engineering) grade, NFPA110 level 1 capable system for life safety applications

If you have any questions please don't hesitate to ask.

Thank You,

Matthew Tassinari
Electrical Systems of Maine
1200 Minot ave
Auburn, ME 04210
207-783-7126
matt@electricalsystemsofmaine.com

Town of Gray
Bid Submission Form

A 100kw 400amp Single Phase LP Generator
A 400amp Service Rated Automatic Transfer Switch

Date of Submission: 7-18-22
Total Price of Equipment and Startup 40,300.00
Price of Generator 33,000.00
Price of ATS 7,300.00 Price of Startup Service ∅

Any specifications that do not meet the minimum specifications must be detailed below:

Includes start up, Battery, Block heater, Delivery

Delivery Date: Transfer SW - In Stock
Generator - 32-38 weeks

Please note: [with operating and repair manuals] shall be consigned to the Town of Gray.

Vendor: Electrical Systems of Maine
Name: Matthew Tassinari
Title of Submission: General Manager

[The Town of Gray reserves the right to accept and/or reject any and all bids]

SG100 | 9.0L | 100 kW
INDUSTRIAL SPARK-IGNITED GENERATOR SET
 EPA Certified Stationary Emergency

DEMAND RESPONSE READY

Standby Power Rating
 100 kW, 125 kVA, 60 Hz

Prime Power Rating*
 90 kW, 113 kVA, 60 Hz

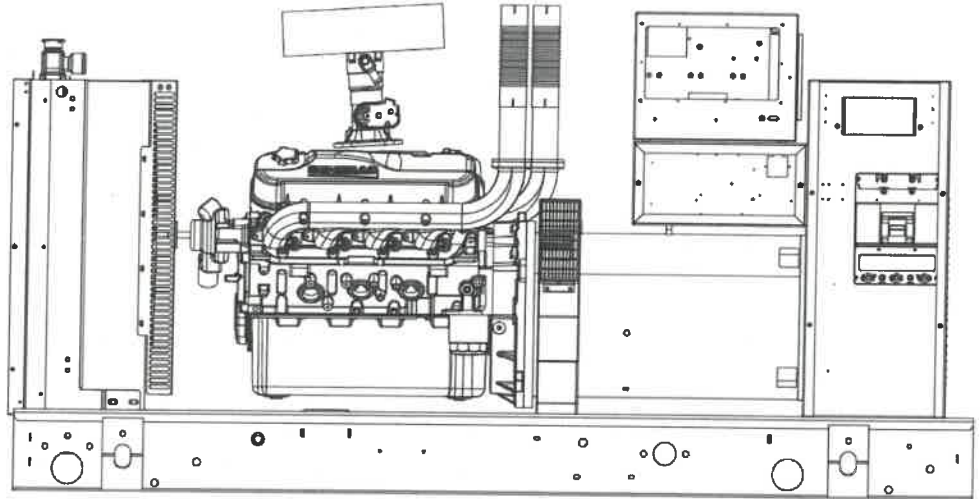

*EPA Certified Prime ratings are not available in the US or its Territories

Image used for illustration purposes only

Codes and Standards

Not all codes and standards apply to all configurations. Contact factory for details.

-   UL2200, UL6200, UL1236, UL489
-  CSA C22.2
-   BS5514 and DIN 6271
-  SAE J1349
-  NFPA 37, 70, 99, 110
-  NEC700, 701, 702, 708
-  ISO 3046, 7637, 8528, 9001
-  NEMA ICS10, MG1, 250, ICS6, AB1
-  ANSI C62.41
-   IBC 2009, CBC 2010, IBC 2012, ASCE 7-05, ASCE 7-10, ICC-ES AC-156 (2012)

Powering Ahead

Generac ensures superior quality by designing and manufacturing most of its generator components, such as alternators, enclosures, control systems and communications software. Generac also makes its own spark-ignited engines, and you'll find them on every Generac gaseous-fueled generator. We engineer and manufacture them from the block up — all at our facilities throughout Wisconsin. Applying natural gas and LP-fueled engines to generators requires advanced engineering expertise to ensure reliability, durability and necessary performance. By designing specifically for these dry, hotter-burning fuels, the engines last longer and require less maintenance. Building our own engines also means we control every step of the supply chain and delivery process, so you benefit from single-source responsibility.

Plus, Generac Industrial Power's distribution network provides all parts and service so you don't have to deal with third-party suppliers. It all leads to a positive owner experience and higher confidence level. Generac spark-ignited engines give you more options in commercial and industrial generator applications as well as extended run time from utility-supplied natural gas.

GENCO-QUIP

SG100 | 9.0L | 100 kW
INDUSTRIAL SPARK-IGNITED GENERATOR SET
 EPA Certified Stationary Emergency

STANDARD FEATURES

DEMAND RESPONSE READY

ENGINE SYSTEM

- Oil Drain Extension
- Air Cleaner
- Fan Guard
- Stainless Steel Flexible Exhaust Connection
- Factory Filled Oil and Coolant
- Radiator Duct Adapter (Open Set Only)
- Critical Silencer (Open Set Only)

Fuel System

- NPT Fuel Connection on Frame
- Primary and Secondary Fuel Shutoff

Cooling System

- Closed Coolant Recovery System
- UV/Ozone Resistant Hoses
- Factory-Installed Radiator
- 50/50 Ethylene Glycol Antifreeze
- Radiator Drain Extension

Electrical System

- Battery Charging Alternator
- Battery Cables
- Battery Tray
- Rubber-Booted Engine Electrical Connections
- Solenoid Activated Starter Motor

ALTERNATOR SYSTEM

- UL2200 GENprotect™
- Class H Insulation Material
- 2/3 Pitch
- Skewed Stator
- Brushless Excitation
- Sealed Bearing
- Amortisseur Winding
- Full Load Capacity Alternator

GENERATOR SET

- Internal Genset Vibration Isolation
- Separation of Circuits - High/Low Voltage
- Separation of Circuits - Multiple Breakers
- Wrapped Exhaust Piping
- Standard Factory Testing
- 2 Year Limited Warranty (Standby and Demand Response Rated Units)
- 1 Year Warranty (Prime Rated Units)
- Silencer Mounted in the Discharge Hood (Enclosed Units Only)

ENCLOSURE (If Selected)

- Rust-Proof Fasteners with Nylon Washers to Protect Finish
- High Performance Sound-Absorbing Material (Sound Attenuated Enclosures)
- Gasketed Doors
- Upward Facing Discharge Hoods (Radiator and Exhaust)
- Stainless Steel Lift Off Door Hinges
- Stainless Steel Lockable Handles
- RhinoCoat™ - Textured Polyester Powder Coat Paint

CONTROL SYSTEM



Digital H Control Panel- Dual 4x20 Display

Program Functions

- Programmable Crank Limiter
- 7-Day Programmable Exerciser
- Special Applications Programmable Logic Controller
- RS-232/485 Communications
- All Phase Sensing Digital Voltage Regulator
- 2-Wire Start Capability
- Date/Time Fault History (Event Log)
- Isochronous Governor Control
- Waterproof/Sealed Connectors
- Audible Alarms and Shutdowns
- Not in Auto (Flashing Light)

- Auto/Off/Manual Switch
- E-Stop (Red Mushroom-Type)
- NFPA110 Level I and II (Programmable)
- Customizable Alarms, Warnings, and Events
- Modbus® Protocol
- Predictive Maintenance Algorithm
- Sealed Boards
- Password Parameter Adjustment Protection
- Single Point Ground
- 16 Channel Remote Trending
- 0.2 msec High Speed Remote Trending
- Alarm Information Automatically Annunciated on the Display

Full System Status Display

- Power Output (kW)
- Power Factor
- kW Hours, Total, and Last Run
- Real/Reactive/Apparent Power
- All Phase AC Voltage
- All Phase Currents
- Oil Pressure
- Coolant Temperature
- Coolant Level

- Engine Speed
- Battery Voltage
- Frequency

Alarms and Warnings

- Oil Pressure
- Coolant Temperature
- Coolant Level
- Low Fuel Pressure
- Engine Overspeed
- Battery Voltage
- Alarms and Warnings Time and Date Stamped
- Snap Shots of Key Operation Parameters During Alarms and Warnings
- Alarms and Warnings Spelled Out (No Alarm Codes)

CONFIGURABLE OPTIONS

DEMAND RESPONSE READY

ENGINE SYSTEM

- Engine Block Heater
- Baseframe Cover/Rodent Guard
- Oil Heater
- Air Filter Restriction Indicator
- Radiator Stone Guard (Open Set Only)
- Level 1 Fan and Belt Guards (Enclosed Units Only)

FUEL SYSTEM

- NPT Flexible Fuel Line

ELECTRICAL SYSTEM

- 10A UL Listed Battery Charger
- Battery Warmer

ALTERNATOR SYSTEM

- Alternator Upsizing
- Anti-Condensation Heater
- Tropical Coating
- Permanent Magnet Excitation

CIRCUIT BREAKER OPTIONS

- Main Line Circuit Breaker
- 2nd Main Line Circuit Breaker
- Shunt Trip and Auxiliary Contact
- Electronic Trip Breakers

GENERATOR SET

- Extended Factory Testing (3-Phase Only)
- 8 Position Load Center
- IBC Seismic Certification
- Pad Vibration Isolators

ENCLOSURE

- Weather Protected Enclosure
- Level 1 Sound Attenuated
- Level 2 Sound Attenuated
- Level 2 Sound Attenuated with Motorized Dampers
- Steel Enclosure
- Aluminum Enclosure
- Up to 200 MPH Wind Load Rating (Contact Factory for Availability)
- AC/DC Enclosure Lighting Kit
- Enclosure Heater (with Motorized Dampers Only)
- Door Open Alarm Switch

CONTROL SYSTEM

- NFPA 110 Compliant 21-Light Remote Annunciator
- Remote Relay Assembly (8 or 16)
- Oil Temperature Indication with Alarm
- Remote E-Stop (Break Glass-Type, Surface Mount)
- Remote E-Stop (Red Mushroom-Type, Surface Mount)
- Remote E-Stop (Red Mushroom-Type, Flush Mount)
- Remote Communication - Modem
- 10A Engine Run Relay
- Ground Fault Annunciator
- Damper Kit Auxiliary Contacts (with Motorized Dampers Only)
- 100 dB Alarm Horn
- 120V GFCI and 240V Outlets

WARRANTY (Standby Gensets Only)

- 2 Year Extended Limited Warranty
- 5 Year Limited Warranty
- 5 Year Extended Limited Warranty
- 7 Year Extended Limited Warranty
- 10 Year Extended Limited Warranty

ENGINEERED OPTIONS

ENGINE SYSTEM

- Coolant Heater Ball Valves
- Fluid Containment Pan

ALTERNATOR SYSTEM

- 3rd Breaker System

CONTROL SYSTEM

- Spare Inputs (x4) / Outputs (x4)
- Battery Disconnect Switch

GENERATOR SET

- Special Testing
- Battery Box

TX301 Series Transfer Switch

100 – 400 Amps

Contactor Type · Open and Delayed Transition · Service Entrance Rated

- Automatic Transfer Switch
- 100 – 400 A, up to 480 VAC, 50/60 Hz, 100% Current Rated
- Single or Three Phase
- 2, 3 or 4 Poles
- NEMA 1 or 3R
- Open and Inphase or Open with Delayed Transition
- ETL Listed to UL 1008
- High Withstand and Closing Ratings



Image used for illustration purposes only

Codes and Standards



ETL Listed



NFPA 70, 99, 110



NEC 700, 701, 702, 708



OSHPD and Seismic Certified CBC
2019, CBC 2016, IBC 2018, IBC 2015,
IBC 2012, IBC 2009, ASCE 7-10,
ASCE 7-16, ICC-ES AC-156

Description

Generac's contactor type transfer switches are double-break robust switch construction with inherent interlocks to ensure safe positive transfer between power sources. The contacts are silver composite for long life, resisting pitting or burning. The switches are rated for full load transfers in mission critical, emergency, legally required, and optional power systems.

The microprocessor based controller provides the customers with the flexibility to program a comprehensive group of set points to match the application needs. The controller has two programmable inputs and one programmable output as standard and is available with optional expansion boards for up to four programmable inputs and outputs. The LCD displays real time and historical information with time-stamped events. The integrated plant exerciser can be configured in off, daily, day of week, biweekly, and monthly intervals with user selectable run time. Standard features of the controller include three phase sensing on both sources, phase unbalance, phase reversal, load shed, emergency inhibit, and communications.

Town of Gray

Mid Maine Generator is looking forward to working with the Town of Gray on their needs for a 100kw Kohler Generator and (1) 400A service rated transfer switch.

We are the largest Kohler dealer in the state and have been for the past 5 years. We have 12 certified Kohler Technicians in the business, and the business is certified to work on liquid cooled Kohler generators up to 150KW. The 100KW Kohler generator we quoted for you will be no problem for us to start up and maintain for the Town of Gray.

I am confident when I say our customer service and attention to detail is better than any other Kohler dealer in the state, bar none! In fact, we were nominated Kohler dealer of the year in 2020.

We are a customer service first business, this business cannot sustain without customers, and we feel customers will not sustain without excellence in customer service. Therefore, customer service is Mid Maine Generator's number one priority.

Mid Maine Generator would like to work with the Town of Gray on this project for a couple reasons. We will make this easy for you, we will give you the best customer service possible during the purchase and startup of these Kohler generators, and will give you the best possible service after the sale. Kohler generator customers are the life blood of this company, and we have dedicated our business to making sure we can help every Kohler customer with an easy process to meet their needs!

Thank you for giving Mid Maine Generator the opportunity to bid this job for the Town Of Gray, we look forward to working with you!

Thank You!

Christopher Moulton

Vice President

(207)395-8066

www.midmainegenerator.com



Titanium Dealer



Town of Gray
Bid Submission Form

A 100kw 400amp Single Phase LP Generator
A 400amp Service Rated Automatic Transfer Switch

Date of Submission: 7.13.2022
Total Price of Equipment and Startup 30,273.00 ^{+ TAX IF APPLICABLE}
Price of Generator 30,773.00 ^{+ CRANE SERVICE}
Price of ATS \$3000.00 Price of Startup Service NO CHARGE

Any specifications that do not meet the minimum specifications must be detailed below:

KOHLER KG 100 - 42WK LEAD TIME
400A RDT SERVICE ENTRANCE RATED - 28WK LEAD TIME

Delivery Date: 42 WEEK LEAD TIME (APPROXIMATE) FOR 100KW, 28WK LEAD TIME ON ATS.

Please note: [with operating and repair manuals] shall be consigned to the Town of Gray.

Vendor: MED MAINE GENERATOR - 207-395-8066
Name: CHRISTOPHER MORTON - CMORTON@MEDMAINEGENERATOR.COM
Title of Submission: GRAY PUBLIC LIBRARY

[The Town of Gray reserves the right to accept and/or reject any and all bids]

ISO 9001
KOHLER
 POWER SYSTEMS
 NATIONALLY REGISTERED

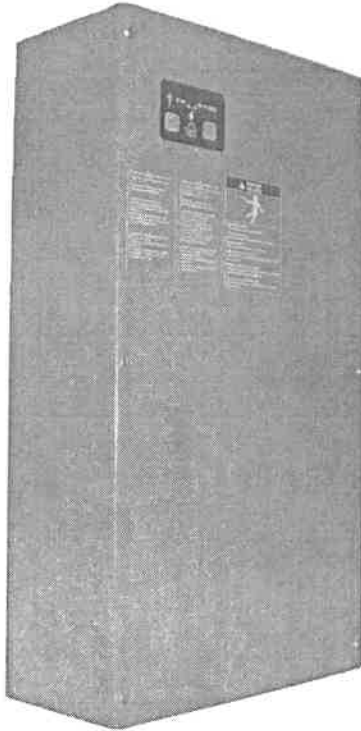

MPAC® 500 Controller Features

- User-friendly interface with easy-to-read international symbols
- Source available and contactor position indicators
- LED indication of system faults
 - Failure to acquire standby source
 - Failure to transfer
 - Auxiliary switch fault
- Common fault contact: latches closed on system faults shown above
- Engine start contact: provides contact closure to start the generator set
- Load control contact: allows 5-minute delay in startup of selected loads
- Test button (with or without load)
- Exercise set button
 - Weekly 20-minute generator set exercise
 - With or without load
- Single-phase voltage sensing on both sources, $\pm 5\%$
- Line-to-line frequency sensing, $\pm 2\%$
- Fixed time delays

Standard Features

- UL listed
 - UL 1008 listed, file #E58962
 - Models with load centers use UL 67 listed components
- cUL listed
 - 100 and 200 amp models with load centers
- CSA certification available, file #LR58301 (not applicable to service entrance or load center models)
- 220/240 VAC, 50/60 Hz (selectable)
- 100, 200, and 400 amp models available
- Two-pole, single-phase open-transition transfer switch
- Contactor electrically and mechanically interlocked
- Double throw inherently interlocked design
- Solid neutral
- Contactor manually operable for maintenance purposes
- Silver alloy main contacts
- Automatic transfer switches are 100% equipment rated and can be applied at the rated current without derating (except service entrance models; see below)
- 100 and 200 amp models available with or without prewired Square D type QO load center
 - 100 amp load center models use up to 16 circuit breakers (up to 8 tandem breakers can be used for a maximum of 24 circuits)
 - 200 amp load center models use up to 24 circuit breakers
 - 200 amp service entrance model with 42-circuit breaker load center is available
- Two enclosures available
 - NEMA Type 1 steel ANSI 49 gray enclosure for indoor installation. 100 amp and 200 amp models without load centers can be recess-mounted between wall studs (not service entrance model)
 - NEMA Type 3R corrosion-resistant aluminum ANSI 49 gray padlockable enclosure. Approved for indoor or outdoor installation
- Five-year limited warranty
- See page 5 for available accessories

Service Entrance Model Features

- 200 and 400 amp service entrance rated automatic transfer switches available
- Service disconnect circuit breaker on the normal (utility) source (80% rated)
- NEMA 3R aluminum ANSI 49 gray enclosure
- Circuit breaker for generator set battery charger
- See page 5 for available SE model accessories



EPA-Certified for 60 Hz Stationary Emergency Applications

EPA certification not applicable at 50 Hz

Ratings Range

Standby:	kW kVA	60 Hz	50 Hz
		77-100 77-125	70-76 70-95

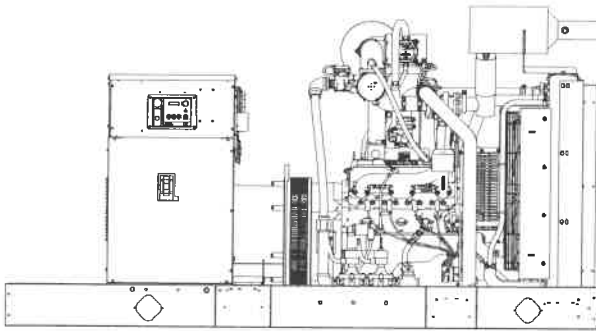

Standard Features

- Kohler Co. provides one-source responsibility for the generating system and accessories.
- The generator set and its components are prototype-tested, factory-built, and production-tested.
- The 60 Hz generator set offers a UL 2200 listing.
- CSA approval is available.
- The 60 Hz generator set meets NFPA 110, Level 1, when equipped with the necessary accessories and installed per NFPA standards.
- The generator set accepts rated load in one step.
- A one-year limited warranty covers all generator set systems and components. Two- and five-year extended limited warranties are also available.
- Alternator features:
 - The unique Fast-Response® X excitation system delivers excellent voltage response and short-circuit capability using a rare-earth, permanent magnet (PM)-excited alternator.
 - The brushless, rotating-field alternator has broadrange reconnectability.
- Natural gas, LP gas, and dual fuel models are available.
- Dual fuel model features:
 - Natural gas is the primary fuel. Automatically transfers back to primary fuel when LPG fuel becomes low or generator stops and restarts.
 - The patent pending reset box on the generator provides the ability to manually transfer back to natural gas.

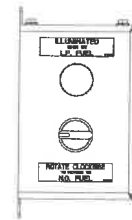

Generator Set Ratings

Alternator	Voltage	Ph	Hz	Natural Gas 130°C Rise Standby Rating		LP Gas 130°C Rise Standby Rating	
				kW/kVA	Amps	kW/kVA	Amps
4R9X	120/208	3	60	100/125	347	100/125	347
	127/220	3	60	100/125	329	100/125	329
	120/240	3	60	100/125	301	100/125	301
	120/240	1	60	77/77	321	77/77	321
	139/240	3	60	100/125	301	100/125	301
	220/380	3	60	91/114	174	91/114	174
	277/480	3	60	100/125	151	100/125	151
	347/600	3	60	100/125	121	100/125	121
	110/190	3	50	76/95	289	76/95	289
	115/200	3	50	76/95	275	76/95	275
	120/208	3	50	76/95	264	76/95	264
	110/220	3	50	76/95	250	76/95	250
	110/220	1	50	70/70	319	70/70	319
	220/380	3	50	76/95	145	76/95	145
	230/400	3	50	76/95	138	76/95	138
	240/415	3	50	76/95	133	76/95	133

RATINGS: All three-phase units are rated at 0.8 power factor. All single-phase units are rated at 1.0 power factor. **Standby Ratings:** The standby rating is applicable to varying loads for the duration of a power outage. There is no overload capability for this rating. Ratings are in accordance with ISO-8528-1 and ISO-3046-1. Obtain technical information bulletin (TIB-101) for ratings guidelines, complete ratings definitions, and site condition derates. The generator set manufacturer reserves the right to change the design or specifications without notice and without any obligation or liability whatsoever.

Generator Set Ratings, continued

Alternator	Voltage	Ph	Hz	Natural Gas		LP Gas	
				130°C Rise		130°C Rise	
				Standby Rating		Standby Rating	
				kW/kVA	Amps	kW/kVA	Amps
4R12X	120/208	3	60	100/125	347	100/125	347
	127/220	3	60	100/125	329	100/125	329
	120/240	3	60	100/125	301	100/125	301
	120/240	1	60	91/91	380	91/91	380
	139/240	3	60	100/125	301	100/125	301
	220/380	3	60	100/125	190	100/125	190
	277/480	3	60	100/125	151	100/125	151
	347/600	3	60	100/125	121	100/125	121
	110/190	3	50	76/95	289	76/95	289
	115/200	3	50	76/95	275	76/95	275
	120/208	3	50	76/95	264	76/95	264
	110/220	3	50	76/95	250	76/95	250
	110/220	1	50	76/76	346	76/76	346
	220/380	3	50	76/95	145	76/95	145
	230/400	3	50	76/95	138	76/95	138
	240/415	3	50	76/95	133	76/95	133
4T13X	120/240	1	60	100/100	417	100/100	417
	110/220	3	50	76/76	346	76/76	346

Alternator Specifications

Specifications	Alternator
Manufacturer	Kohler
Type	4-Pole, Rotating-Field
Exciter type	Brushless, Rare-Earth Permanent Magnet
Leads: quantity, type	
4RX	12, Reconnectable
4TX	4, 110- 120/220- 240 V
Voltage regulator	Solid State, Volts/Hz
Insulation:	NEMA MG1
Material	Class H
Temperature rise	130°C, Standby
Bearing: quantity, type	1, Sealed
Coupling	Flexible Disc
Amortisseur windings	Full
Voltage regulation, no-load to full-load	Controller Dependent
One-step load acceptance	100% of Rating
Unbalanced load capability	100% of Rated Standby Current
Peak motor starting kVA:	(35% dip for voltages below)
480 V, 400 V 4R9X (12 lead)	385 (60 Hz), 296 (50 Hz)
480 V, 400 V 4R12X (12 lead)	448 (60 Hz), 355 (50 Hz)
240 V, 220 V 4T13X (4 lead)	440 (60 Hz), 396 (50 Hz)

- NEMA MG1, IEEE, and ANSI standards compliance for temperature rise and motor starting.
- Sustained short-circuit current of up to 300% of the rated current for up to 10 seconds.
- Sustained short-circuit current enabling downstream circuit breakers to trip without collapsing the alternator field.
- Self-ventilated and dripproof construction.
- Superior voltage waveform from a two-thirds pitch stator and skewed rotor.
- Windings are vacuum-impregnated with epoxy varnish for dependability and long life.

Application Data

Engine

Engine Specifications	60 Hz	50 Hz
Manufacturer	Kohler	
Engine: model, type	KG6208THD 6.2 L Turbocharged, Aftercooled	
Cylinder arrangement	V-8	
Displacement, L (cu. in.)	6.2 (378)	
Bore and stroke, mm (in.)	101.6 x 95.25 (4.00 x 3.75)	
Compression ratio	9.8:1	
Rated rpm	1800	1500
Max. power at rated rpm, kW (HP)		
NG	152 (204)	125 (168)
LP	131 (175)	109 (146)
Cylinder head material	Cast Aluminum	
Piston type and material	Cast Aluminum	
Crankshaft material	Forged steel	
Valve (exhaust) material	Forged Steel	
Governor type	Electronic	
Frequency regulation, no-load to full-load	Isochronous	
Frequency regulation, steady state	±1.0%	
Frequency	Fixed	
Air cleaner type, all models	Dry	

Exhaust

Exhaust System	60 Hz	50 Hz
Exhaust manifold type	Dry	
Exhaust flow at rated kW, m ³ /min. (cfm)	24 (848)	20 (706)
Exhaust temperature at rated kW, dry exhaust, °C (°F)	700 (1292)	650 (1202)
Maximum allowable back pressure, kPa (in. Hg)	15 (4.43)	12 (3.54)
Exhaust outlet size at engine hookup, mm (in.)	88.9 (3.5)	

Engine Electrical

Engine Electrical System	60 Hz	50 Hz
Ignition system	Coil Pack	
Battery charging alternator:		
Ground (negative/positive)	Negative	
Volts (DC)	12	
Ampere rating	130	
Starter motor rated voltage (DC)	12	
Battery, recommended cold cranking amps (CCA):		
Qty., rating for -18°C (0°F)	One, 650	
Battery voltage (DC)	12	

Fuel

Fuel System	60 Hz	50 Hz
Fuel type	Natural Gas, LP Gas, or Dual Fuel	
Fuel supply line inlet	1.5 NPT	
Natural gas and LPG vapor fuel supply pressure, kPa (in. H ₂ O)	1.74-2.74 (7-11)	
Fuel Composition Limits *	Nat. Gas	LP Gas
Methane, % by volume	90 min.	—
Ethane, % by volume	4.0 max.	—
Propane, % by volume	1.0 max.	85 min.
Propene, % by volume	0.1 max.	5.0 max.
C ₄ and higher, % by volume	0.3 max.	2.5 max.
Sulfur, ppm mass	25 max.	
Lower heating value, MJ/m ³ (Btu/ft ³), min.	33.2 (890)	84.2 (2260)

* Fuels with other compositions may be acceptable. If your fuel is outside the listed specifications, contact your local distributor for further analysis and advice.

Lubrication

Lubricating System	60 Hz	50 Hz
Type	Full Pressure	
Oil pan capacity, L (qt.) §	5.7 (6.0)	
Oil pan capacity with filter and oil cooler, L (qt.) §	9.0 (9.5)	
Oil filter: quantity, type §	1, Cartridge	
§ Kohler recommends the use of Kohler Genuine oil and filters.		

Cooling

Radiator System	60 Hz	50 Hz
Ambient temperature, °C (°F) *	50 (122)	
Engine jacket water capacity, L (gal.)	7.3 (1.93)	
Radiator system capacity, including engine, L (gal.)	28.4 (7.5)	
Engine jacket water flow, Lpm (gpm)	126 (33.3)	105 (27.7)
Heat rejected to cooling water at rated kW, dry exhaust, kW (Btu/min.)	73.9 (4207)	61.5 (3501)
Heat rejected to charge air cooler at rated kW, dry exhaust, kW (Btu/min.)	18 (1025)	15 (854)
Water pump type	Centrifugal	
Fan diameter, including blades, mm (in.)	711 (28)	
Fan, kWm (HP)	12 (16.1)	7.0 (9.4)
Max. restriction of cooling air, intake and discharge side of radiator, kPa (in. H ₂ O)	0.12 (0.5)	

* Enclosure with enclosed silencer reduces ambient temperature capability by 5°C (9°F).

Operation Requirements

Air Requirements	60 Hz	50 Hz
Radiator-cooled cooling air, m ³ /min. (scfm) †	290 (10,241)	242 (8,546)
Combustion air, m ³ /min. (cfm)	6.9 (244)	5.8 (205)
Heat rejected to ambient air:		
Engine, kW (Btu/min.)	30 (1708)	23 (1309)
Alternator, kW (Btu/min.)	8 (455)	6 (342)

† Air density = 1.20 kg/m³ (0.075 lbm/ft³)

Fuel Consumption ‡	60 Hz	50 Hz
Natural Gas, m ³ /hr. (cfh) at % load	Standby Ratings	
100%	41.7 (1473)	31.9 (1126)
75%	34.7 (1224)	26.3 (928)
50%	26.8 (946)	19.4 (685)
25%	17.7 (625)	13.0 (458)
0%	8.3 (292)	7.1 (252)
LP Gas, m ³ /hr. (cfh) at % load	Standby Ratings	
100%	18.8 (664)	12.6 (444)
75%	15.1 (532)	9.2 (325)
50%	11.0 (388)	6.1 (214)
25%	6.1 (216)	4.2 (147)
0%	3.4 (121)	2.5 (88)

‡ Nominal fuel rating: Natural gas, 37 MJ/m³ (1000 Btu/ft.³)
LP vapor, 93 MJ/m³ (2500 Btu/ft.³)

LP vapor conversion factors:

8.58 ft.³ = 1 lb.

0.535 m³ = 1 kg.

36.39 ft.³ = 1 gal.

Controllers

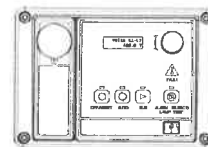

APM402 Controller

Provides advanced control, system monitoring, and system diagnostics for optimum performance and compatibility.

- Digital display and menu control provide easy local data access
- Measurements are selectable in metric or English units
- Remote communication thru a PC via network or serial configuration
- Controller supports Modbus® protocol
- Integrated hybrid voltage regulator with ±0.5% regulation
- Built-in alternator thermal overload protection
- NFPA 110 Level 1 capability

Refer to G6-161 for additional controller features and accessories.

Modbus® is a registered trademark of Schneider Electric.



APM603 Controller

Provides advanced control, system monitoring, and system diagnostics for optimum performance and compatibility.

- 7-inch graphic display with touch screen and menu control provides easy local data access
- Measurements are selectable in metric or English units
- Paralleling capability to control up to 8 generators on an isolated bus with first-on logic, synchronizer, kW and kVAR load sharing, and protective relays
- Note: Parallel with other APM603 controllers only
- Generator management to turn paralleled generators off and on as required by load demand
- Load management to connect and disconnect loads as required
- Controller supports Modbus® RTU, Modbus® TCP, SNMP and BACnet®

- Integrated voltage regulator with ±0.25% regulation
- Built-in alternator thermal overload protection
- UL-listed overcurrent protective device
- NFPA 110 Level 1 capability

Refer to G6-162 for additional controller features and accessories.

BACnet® is a registered trademark of ASHRAE.

Standard Features

- Air Cleaner Restrictor Indicator
- Alternator Protection
- Battery Rack and Cables
- Dual Fuel Reset Box (standard on dual fuel models)
- Electronic, Isochronous Governor
- Gas Fuel System (includes fuel mixer, electronic secondary gas regulator, gas solenoid valve, and flexible fuel line between the engine and the skid-mounted fuel system components)
- Integral Vibration Isolation
- Local Emergency Stop Switch
- Oil Drain Extension
- Operation and Installation Literature
- Open Unit Accessory Kit (radiator duct flange, stone guard, flexible exhaust, and three-way catalyst)
- Three-Way Exhaust Catalyst

Available Options

Circuit Breakers

Type

- Magnetic Trip
- Thermal Magnetic Trip
- Electronic Trip (LI)
- Electronic Trip with Short Time (LSI)
- Electronic Trip with Ground Fault (LSIG)

Rating

- 80%
- 100%

Operation

- Manual
- Electrically Operated (for paralleling)

Circuit Breaker Mounting

- Generator Mounted
- Remote Mounted
- Bus Bar (for remote mounted breakers)

Enclosures for Remote Mounted Circuit Breakers

- NEMA 1
- NEMA 3R

Approvals and Listings

- CSA Approval
- IBC Seismic Certification
- UL 2200 Listing
- Hurricane Rated Enclosure

Enclosure

- Sound Enclosure (with enclosed critical silencer)
- Weather Enclosure (with enclosed critical silencer)

Open Unit

- Exhaust Silencer, Critical
- Flexible Exhaust Connector, Stainless Steel

Fuel System

- Dual Fuel NG/LPG (automatic changeover)
- Flexible Fuel Line
- Fuel Filter Kit
- Secondary Gas Solenoid Valve (NFPA Fuel System)

Controller

- Common Failure Relay (APM603 Controller only)
- Four Input/Fifteen Output Module
- Lockable Emergency Stop
- Manual Key Switch (APM603 only)
- Manual Speed Adjust (APM402 only)
- Remote Emergency Stop
- Run Relay (Standard with APM603)
- Remote Annunciator panel
- Two Input/Five Output Module (APM402 only)

Cooling System

- Block Heater, 1500 W, 110- 120 V
- Block Heater, 1500 W, 190- 240 V
Recommended for ambient temperatures below 10°C (50°F)

Electrical System

- Battery
- Battery Charger
- Battery Charger Temperature Compensation
- Battery Heater
- Generator Heater

Miscellaneous

- Certified Test Report
- Engine Fluids Added
- Rated Power Factor Testing
- Rodent Guards

Literature

- General Maintenance
- NFPA 110
- Overhaul
- Production

Warranty

- 2-Year Basic Limited Warranty
- 5-Year Basic Limited Warranty
- 5-Year Comprehensive Limited Warranty

Dimensions and Weights

Overall Size, L x W x H, mm (in.) :

2800 x 1120 x 1528 (110.2 x 44.1 x 60.2)

Weight, wet, kg (lb.):

1207 (2660)

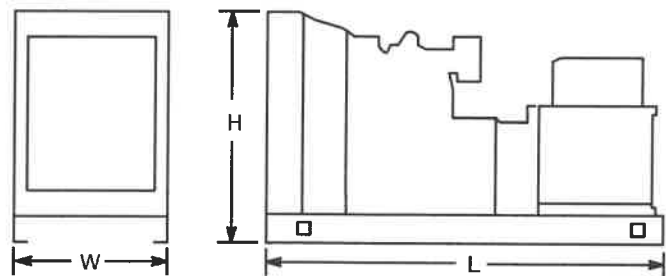

NOTE: This drawing is provided for reference only and should not be used for planning installation. Contact your local distributor for more detailed information.

DISTRIBUTED BY:



TOWN OF GRAY

Henry Pennell Municipal Complex
22B Main St, Gray Maine 04039
www.graymaine.org

DEPARTMENT OF BUILDINGS AND
GROUNDS

Mo Russo III, Director
mrusso@graymaine.org
207-657-3339 ext.131

MEMO

To: Nate Rudy, Town Manager
Gray Town Council

From: Mo Russo, Director of Buildings and Grounds

Date: July 27, 2022

Re: Pennell LED Sign

A Request for Proposal was issued for the replacement of the LED sign and skin located along Main Steet for the Pennell Municipal Complex. Certified Mail with Return Receipt were sent to; Bailey Sign, Barlo Signs, and Neokraft Signs. The Request for Proposal was published on the Town's website which brought a significant interest to the project. The budget for this project is \$32,000.

The Town received three bids which were opened at noon on Thursday July 21st. Blink Signs of Cleveland, OH bid \$24, 208.98, Neokraft Signs of Lewiston, ME bid \$32,076.03, and United Signs of Norcross, GA bid \$22,900.

Blink Signs was removed from consideration as the LED sign they proposed was smaller than the issued RFP stated.

After follow up emails and phone calls to United Signs and Neokraft it is my recommendation to award the bid to United Signs of Norcross GA based upon cost. United uses local contractors to install and service the sign. The contractor is located within an hour travel time of Gray.

Cover Letter



July 21, 2022

Dear Purchasing,

United Signs, LLC. ("United") is pleased to present this proposal to The Town of Gray ("Town") for a New LED Outdoor Sign. We fully understand the requirements as described in the RFP and stand ready to contribute to achieving results that will exceed your expectations.

United is recognized as a National Leader for our custom architectural sign manufacturing. Our work is featured in the finest hotels, government entities, corporate offices, universities, hospitals, small businesses, and institutions throughout the Southeast and beyond. We take great pride that much of our products are fabricated by our talented in-house crew who work together with our expert project managers. As the Town will evaluate its potential signage partners, we are certain that it will take note of:

- The experience, proven capabilities, and wide resource bandwidth we offer.
- Our outstanding reputation with our current clients (references provided).
- Our partnership approach to support; and
- That those attributes set us apart from our competitors.

To provide expedited communications between the Town and United, I will serve as the Town's primary point of contact during the procurement process. Please do not hesitate to contact me for clarification on any of our responses or any additional information required by the Town. The contact information is listed below:

Phone: 770-899-8128

Email: jowens@unitedsignsga.com

We look forward to a favorable review of our proposal and stand ready to answer any questions posed by the Town related to our solutions or capabilities.

Sincerely,



Jared Owens
Sr. Bid Director

Company Overview

Description of Firm

United Signs has a background of specializing in the design and fabrication of Architectural Signage. Whether there is a need for wayfinding signage that guides you through neighborhoods, malls, hospitals, and resorts, that get you to your destination or a LED billboard signs that sends a welcoming message to guest and customers United has it all. We provide artfully crafted visual identities for communication through signage. Our lighting and maintenance expertise allows you to maintain your investment throughout its lifetime. At United Signs we know that your customers, clients, and patrons will see our creations, and because of that we obsess over every detail. We are confident that you will work with us time and time again because of our dedication.

Our Mission

To glorify God as we deliver quality products and services through Integrity, Trust & Respect for others. While we aim to foster long-term relationships by meeting and exceeding our customers' high expectations and earning their trust for years to come. We provide quality signage, displays and fixtures, services, and solutions to our customers. In achieving this mission, we treat our employees, vendors, partners, and customers with integrity, while cultivating an environment that everyone admires and respects.

Our Values

- **LOVE.** Treat others like you would want to be treated.
- **SERVANT'S HEART.** Lead with what people need.
- **EXCELLENCE.** Do great things with the gifts you have been given.
- **COURAGE.** Learn, improve, and boldly drive change that matters.
- **FUN.** Work hard, laugh often.

Why Us?

United provides modern and attractive signs that will help you thrive through effective communication. Unlike other sign companies, we design and build our own complete sign solutions and provide them to you through the easiest process in the industry.

Designed and Built by Us We develop the whole sign system from the ground up. From the all-aluminum cabinets to the software in our electronic signs, our products are made for ease-of-use and a great experience.

EdgeX Electronic Message Center Projects



Quote

Quote

BILL TO :

City of Gray

Mo Russo
Director of Buildings and Grounds

DUE DATE :

TBD

QT#-8461

Qty	Description	Price	Amount
-----	-------------	-------	--------

**Turnkey Full Service EMC
Marquee Sign**

1

DF - P10 @ 37.8" x 75.6 = \$11,200.00
Electrical Box = \$1,200.00
Shipping to Maine = \$2,500.00
Demo old existing sign face \$1,000.00
Build new sign cabinet = \$4,500
Install = \$2,500

\$22,900.00

\$22,900.00

SUBTOTAL

\$22,900.00

TOTAL PRICE

\$22,900.00



Thank You



Maine Municipal Association

60 COMMUNITY DRIVE
AUGUSTA, MAINE 04330-9486
(207) 623-8428
www.memun.org

Memorandum

To: Key Municipal Officials of MMA's Member Municipalities
From: James Bennett, President, Maine Municipal Association
Date: June 23, 2022
Re: Ballot for Election to MMA's Legislative Policy Committee



MMA's member municipalities have made their nominations for the 2022-2024 Legislative Policy Committee (LPC). It is now time to elect your representatives to serve on the Committee. The election ballot is enclosed. The ballot must be completed by the Board of Selectmen or Town/City Council of your municipality.

Number of votes

A majority of municipalities are being asked to vote for two candidates, because there are two elected LPC members for most districts. Some municipalities only vote for one candidate, because the other LPC member in that district is appointed. ***You are instructed on the ballot (above the list of candidates) whether to vote for two candidates or just one.***

Candidate profiles

If you are not familiar with any of the candidates, please review the Candidate Profiles on the back of the ballot. Feel free, also, to contact the candidates directly.

Write-in candidates

In addition to the candidates listed on the ballot, you may vote for a candidate whose name is not on the ballot by writing that person's name in. The write-in candidate need not be from your municipality but must be an elected or appointed official from a municipality in your Senate/LPC District. ***Check to be sure the write-in candidate is willing to serve if elected!*** Write-in candidates should be communicating their interest in serving among the municipal officers within their district.

If you are instructed to vote for two candidates and only one candidate is on the ballot, please use the "write-in" line for your second vote if you know of someone who is willing to serve.

Deadline for returning ballot

Return to ballot by 5:00 p.m. on **August 11, 2022** to Laura Ellis either in the enclosed envelope, via email (lellis@memun.org) or FAX: 624-0129

Your participation is important – Thank You!

OFFICIAL BALLOT – District 25

Maine Municipal Association’s Legislative Policy Committee
July 1, 2022 – June 30, 2024

VOTE FOR TWO:

Nathaniel Rudy, Town Manager, Town of Gray

Janice De Lima, Councilor, Town of Falmouth

Mark Segrist, Councilor, Town of Cumberland

_____ (name) _____ (position) _____ (municipality)  write in)

Candidate Profiles Are On Reverse Side

MUNICIPALITY: _____ DATE: _____

 BY SELECTMEN/COUNCILORS:

_____ signature

_____ print name

_____ signature

_____ print name

_____ signature

_____ print name

_____ signature

_____ print name

_____ signature

_____ print name

Return by 5:00 p.m., August 11, 2022 to:

Laura Ellis, Maine Municipal Association
lellis@memun.org
Fax: 624-0129

LPC Senate District 25

Cumberland
Falmouth

Gray
Long Island

North Yarmouth
Yarmouth (part)

Candidate Profile:

Nathaniel Rudy has served municipal government in several capacities for the past 11 years, most recently as Town Manager in Gray for a little over a year. Prior to that he served as City Manager in Hallowell, Director of Planning and Development for the City of Gardiner and currently serves as the citizen member of the Readfield Solid Waste Committee. Nate served on the LPC from 2018-2021 and would like to serve again to represent Gray's interest in matters involving housing, transportation, taxation, labor and community economic development opportunities.

Janice De Lima has served Town Councilor in Falmouth for the past three years. During that time, she has served on several committees, including Finance, Appointments and CDC. She would like to serve on the LPC because Maine faces many challenges, including an aging population, lack of good housing that is affordable to our seniors, to name a couple. She believes that municipalities have to develop solutions now more than ever before if we expect to have a vibrant and economically successful state. She believes we have much potential if we can work towards a common shared vision. She'd also like to serve because she feels that this is where policy must be worked out for our member municipalities.

Mark Segrist has served as Town Councilor in Cumberland for the past year and prior to that served on the Lands & Conservation Commission and Climate Action Plan Subcommittee. He would like to serve on the LPC to ensure that legislation passed at the state level (e.g., property tax deferral, affordable housing, climate action programs, etc.) not only addresses the specific issues municipalities face, but also, that it is tailored in such a way to encourage increased use and adoption at the local level.

STATE OF MAINE

—
IN THE YEAR OF OUR LORD
TWO THOUSAND TWENTY-TWO

—
S.P. 126 - L.D. 290

**An Act To Stabilize Property Taxes for Individuals 65 Years of Age or Older
Who Own a Homestead for at Least 10 Years**

Be it enacted by the People of the State of Maine as follows:

Sec. 1. 36 MRSA c. 908-B is enacted to read:

CHAPTER 908-B

PROPERTY TAX STABILIZATION FOR SENIOR CITIZENS

§6281. Stabilization of property taxes on homesteads of individuals 65 years of age or older

1. Definitions. As used in this chapter, unless the context otherwise indicates, the following terms have the following meanings.

A. "Eligible homestead" means a homestead occupied by an eligible individual who is eligible for a homestead exemption under chapter 105, subchapter 4-B for the property tax year during which an application for stabilization is made.

B. "Eligible individual" means an individual who:

(1) Is 65 years of age or older; and

(2) Is a permanent resident of the State as defined in section 681, subsection 4 who has owned a homestead in the State for at least 10 years.

C. "Homestead" has the same meaning as under section 681, subsection 2.

D. "Stabilize" means to maintain the property tax billed to an eligible individual for the individual's eligible homestead at the amount billed for that homestead for the property tax year preceding the date of application for stabilization.

2. Application for stabilization. An individual may apply by December 1st to the municipality in which the individual's homestead is located requesting that the municipality stabilize the property tax assessed on that individual's homestead for the property tax year beginning on April 1st following the submission of the application. A new application is required for each year for which stabilization is requested.

3. Stabilization for eligible individual. If a municipality determines that an applicant for stabilization under subsection 2 is an eligible individual and that the individual's homestead is an eligible homestead, the municipality shall stabilize the property tax on the individual's homestead billed for the property tax year for which stabilization was requested.

4. Transfer of eligibility. If an eligible individual has been eligible for stabilization under this section and establishes a new homestead in the State, the individual continues to be eligible for stabilization. If an eligible individual establishes a new homestead in a different municipality, at the request of the eligible individual, the municipality where eligibility was first established shall notify the new municipality of the eligible individual's previous eligibility and the amount at which the property taxes were stabilized. The new municipality shall bill the eligible individual at the stabilized amount and is eligible for state compensation under subsection 5.

5. State compensation. A municipality that has stabilized property tax for an eligible individual under this chapter may recover from the State 100% of the amount by which the property tax assessed on the homestead of an eligible individual in the usual manner exceeds the stabilized amount of property tax billed under subsection 3. A municipality claiming compensation under this subsection shall submit a claim to the bureau by November 1st of the year in which the property tax was stabilized. The bureau shall review claims and determine the total amount to be paid to each municipality. The bureau shall certify and the Treasurer of State shall pay the amount due to each municipality by January 15th of the year following the year in which the claim for compensation was submitted.

Sec. 2. Appropriations and allocations. The following appropriations and allocations are made.

ADMINISTRATIVE AND FINANCIAL SERVICES, DEPARTMENT OF

Revenue Services, Bureau of 0002

Initiative: Provides funding for one property appraiser, one half-time, temporary property appraiser, mandate reimbursement costs and All Other costs to process and audit applications.

GENERAL FUND	2021-22	2022-23
POSITIONS - LEGISLATIVE COUNT	0.000	1.500
Personal Services	\$0	\$107,624
All Other	\$0	\$207,618
GENERAL FUND TOTAL	\$0	\$315,242



TOWN OF GRAY

Henry Pennell Municipal Complex
24 Main St, Gray Maine 04039
www.graymaine.org

OFFICE OF THE ASSESSOR

Lauren Asselin, Assessor
lasselin@graymaine.org
(207) 657-3339 ex. 112

July 28, 2022

Assessing Department Report to Town Manager (6/25/2022 – 7/22/2022):

- 6/30 and 7/14 - Attended Sebago Lakes Region Rotary Club meeting
- 7/4 through 7/8 - Vacation

Other Activities/Accomplishments:

- 7/14 – Attended Department Head Meeting
- 7/22 – Meeting with Jon Briggs (Hygrade Business Group)
- LD 290 – Property Tax Stabilization discussions
- Completed data input for inspections
- Continued work on 2023 tax commitment

Challenges / Obstacles:

- Conversion to Trio Web:
 1. Pictures and sketches did not transfer over correctly
 2. Picture and sketch reports not processing
 3. Several search functions are not working
 4. There are issues with the time-out function - **Corrected**
 5. Addresses for condo units not appearing
 6. Printing error in Personal Property module
 7. Data input tab function error

In addition to the items listed above, it was discovered that our property accounts are not calculating correctly causing a standstill for commitment calculations. Trio has been working on correcting the issue – **Corrected**



TOWN OF GRAY

Henry Pennell Municipal Complex
24 Main St, Gray Maine 04039
www.graymaine.org

DEPARTMENT OF BUILDING AND
GROUNDS

Mo Russo III, Director
mrusso@graymaine.org
207-657-3339 ext.131

July 28,2022

Department of Buildings and Grounds Report to Town Manager 6/25-7/27/2022

- 6/30 Met with Gray Historical Society to discuss findings of Port City Architectures Condition Assessment
- 7/04 Department Observed July 4th Holiday
- 7/05 Attended Council Meeting regarding Wilkies Beach Boat Ramp, Gorrill-Palmer's proposal for Pennell Septic Design, and to have New England Mountain Bike Associations perform trail work at Libby Hill
- 7/09 Attended Ribbon Cutting Ceremony for Thayer Brook Preserve
- 7/14 Attended Department Head Meeting and Block Party Meeting
- 7/19-20 Mowing at Libby Hill
- 7/20 Submitted Boat Ramp Grant Application
- 7/21 Bids opened for Pennell LED Sign, and Library Generator

Town Council Tracking Worksheet Items:

- Libby Hill Items

Other Activities / Accomplishments:

- Department assisted with the bridge construction of Thayer Brook Bridge on the Outback Trail
- Floor finish at Dry Mills Schoolhouse has been remedied
- Kitchen Range in Pennell is now operational
- Discussion with Steve McPike regarding overall signage at Libby Hill
- 20 Requests for Service for the period of 6/25-7/27 outside of normal daily routine.
- Contractor has dug post holes for various signage

Challenges / Obstacles Requiring Assistance Outside of the Department:

- Public Works assisted with various items including instillation of No Parking Signs on Libby Hill and setting the banner on Village Gateway
- Anthony and Kyle assisted with aspects of the Boat Ramp Grant
- Normal operations of the department are hindered when staff are on vacation, coupled with staff being out.
- Communication needs improvement



COMSTAR



(Computer Oriented Mapping, Utilizing Statistical Tracking, Accountability and Response)

Cumberland County Sheriff's Office

Town of Gray

Month of June 2022

Prepared by Crime Analyst Wendy Clark-Tarbox

Calls for Service

<u>June 2021</u>	<u>May 2022</u>	<u>June 2022</u>	<u>2022 Difference</u>	<u>2022 % Change</u>
436	469	526	+57	+12.2%

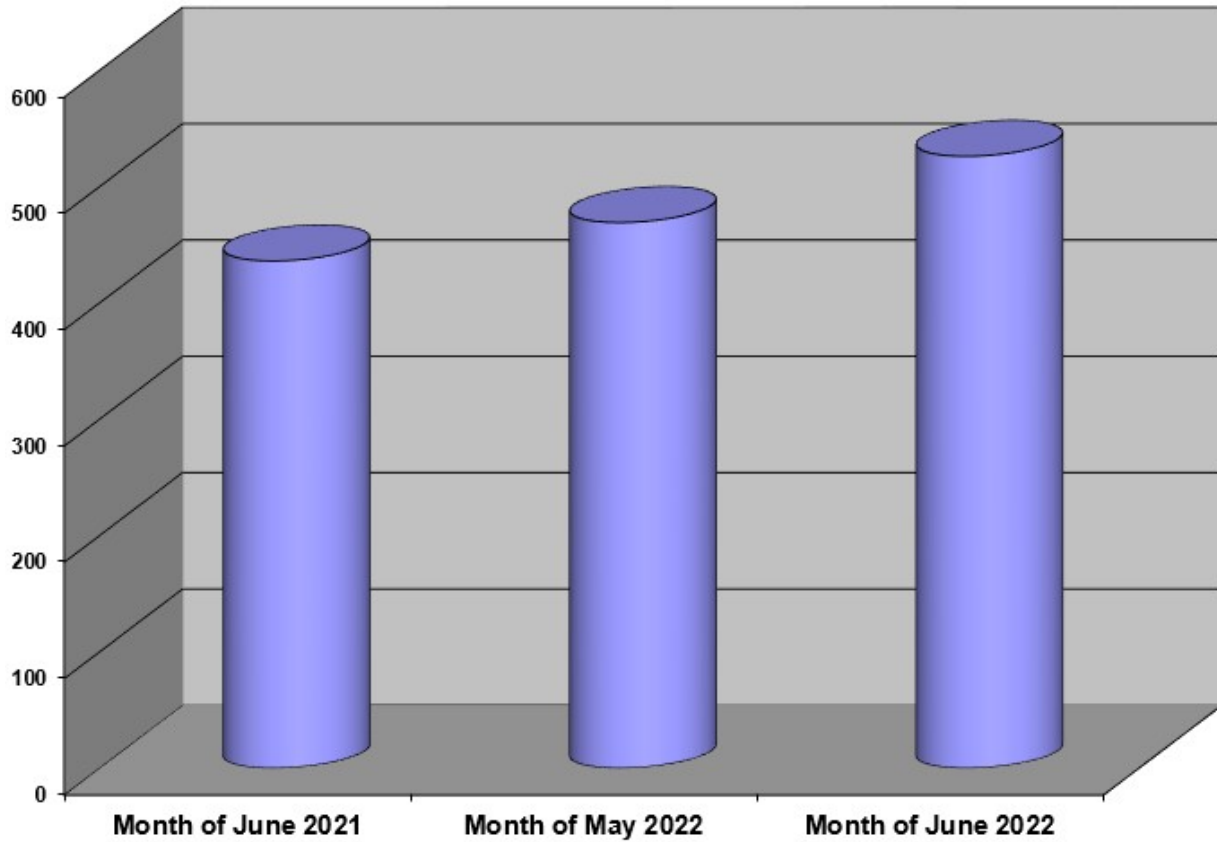

Crime Totals -

	<u>June 2021</u>	<u>May 2022</u>	<u>June 2022</u>	<u>2022 Difference</u>	<u>2022 % Change</u>
Arson	0	0	0	n/c	n/c
Assault	1	1	3	+2	+200%
Burglary	0	2	0	-2	-100%
Burglary to MV	0	0	1	+1	undefined
Domestic Related Incidents (from Calls for Service)	26	11	12	+1	+9.1%
Rape/Sex Offense	1	1	2	+1	+100%
Robbery	0	0	0	n/c	n/c
Theft	2	5	1	-4	-80%
Theft of Motor Vehicle	0	1	0	-1	-100%

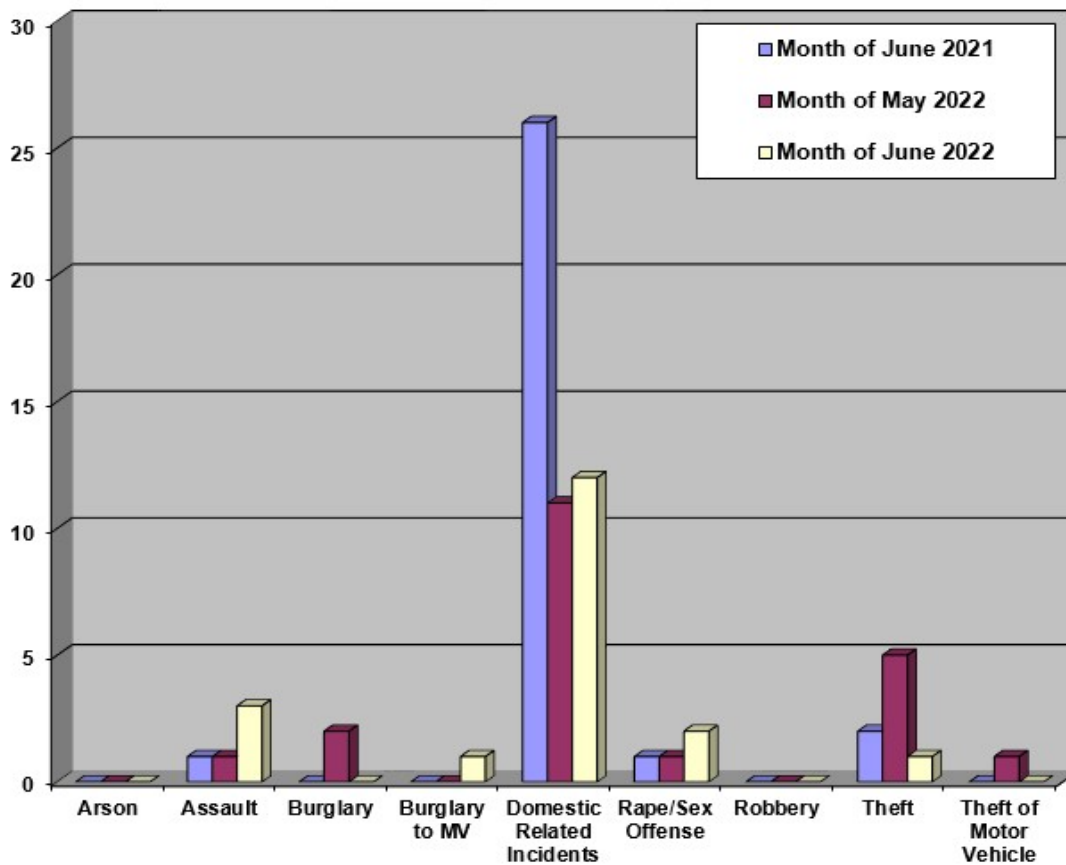

Traffic Totals -

	<u>June 2021</u>	<u>May 2022</u>	<u>June 2022</u>	<u>2022 Difference</u>	<u>2022 % Change</u>
Reportable Accidents	18	19	17	-2	-10.5%
Non-Reportable Accidents	4	2	5	+3	+150%
Traffic Related Citations Total	28	25	35	+10	+40%
OAS Citations	4	5	4	-1	-20%
OUI	3	2	4	+2	+100%
Speeding Citations	14	6	11	+5	+83.3%
Traffic Stops	77	153	180	+27	+17.6%
Written Warnings	41	139	156	+17	+12.2%

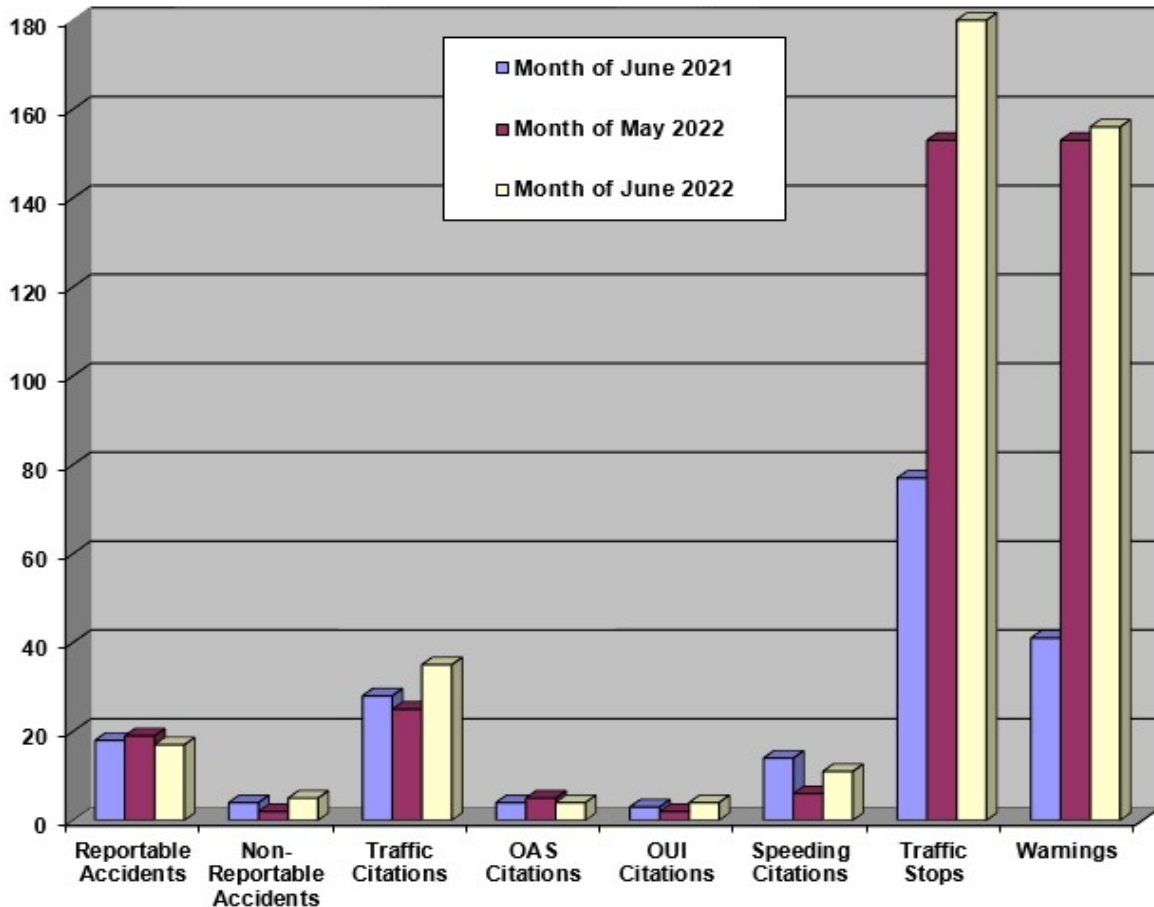

Quality of Life Incidents -

	<u>June 2021</u>	<u>May 2022</u>	<u>June 2022</u>	<u>2022 Difference</u>	<u>2022 % Change</u>
Agency Assists	16	15	17	+2	+13.3%
Alarms	14	7	9	+2	+28.6%
Animal Problem	3	2	8	+6	+300%
Attempt to Locate (i.e. vehicles operating erratically)	37	23	33	+10	+43.5%
Citizen Assists/ Disputes	39	35	26	-9	-25.7%
Concealed Firearms Investigations	4	5	1	-4	-80%
Court Services (Protection Orders and Summonses)	10	2	2	n/c	n/c
Criminal Mischief	1	2	0	-2	-100%
Criminal Trespass	3	2	2	n/c	n/c
Disabled Vehicles/ Assist Motorist	7	7	12	+5	+71.4%
Disturbances/Fights/ Loud Party	6	4	4	n/c	n/c
Fraud	3	2	5	+3	+150%
Missing Persons	1	0	1	+1	undefined
Pedestrian Checks	4	1	6	+5	+500%
Property Checks	4	23	33	+10	+43.5%
Sex Offender Registry Investigations	3	1	4	+3	+300%
Suspicious Persons/ Circumstances	18	22	9	-13	-59.1%
Welfare Checks/ Suicide-Attempted Suicide/ Mental Health Event	23	22	23	+1	+4.5%



TOWN OF GRAY

Henry Pennell Municipal Complex
24 Main St, Gray Maine 04039
www.graymaine.org

OFFICE OF THE LIBRARY DIRECTOR

Josh Tiffany, Director of IT/Com/Library
jtiffany@graymaine.org
(207) 657-4110

July 28, 2022

MEMORANDUM

To: Nathaniel Rudy

From: Joshua Tiffany

July 2022 monthly report to the Town Manager for Libraries, Information Technology, and Communications.

For Gray Public Library:

The Gray Public Library took further steps towards the return to normal in terms of our regular programming. The Library has restarted its popular Movie Time! program. While the screenings were scheduled to begin in May, staffing shortages and demands for the room space prevented any consistent screenings until July. Since resuming our normal schedule of an afternoon films on Tuesdays and Saturdays, our audience has been returning. In July, we screened eight films with a total attendance of 29.

The Library's Summer Reading was able to return to in-person programming for the first time since the summer of 2019. We had 57 children sign up to take part in the Summer Reading Program and received activity packets and a reading log. The library kept up its summer tradition of adding new laminated book to the Story Walk that surrounds our parking lot. As part of Summer Reading, we hosted internationally acclaimed story-teller Antonio Rocha, Chewonki presented Fins and Flippers, local marine biologist author Mary Cerullo presented a PowerPoint on Mysterious Creatures of the Deep, and next week we will conclude with a visit from Ladder – a 50-foot inflatable whale that children can climb inside to learn about the inner workings of Fin Whales. To date, 97 children attended our in-person programming this summer. The Gray Public Library Association once again demonstrated their determination to aid and assist the programming of the Gray Public Library by donating all the funds for all Summer Reading activities. Additionally, our virtual Story Times are broadcast over Facebook twice a week, and shown on GCTV on Monday afternoons.

The Library welcome our new Head of Circulation, Andrea Kazilionis. Andrea comes to Gray after working at the Falmouth Memorial Library and the Wells Public Library, where she served as Adult Services Librarian at both locations. Additionally, she worked at the Maine State Law and Legislative Reference Library in Augusta. She received her Master of Library Science from

University of North Texas in 2019. Andrea is filling the position left vacant by Darcel Devou, who was promoted to Assistant Library Director in June of this year.

The use of the Library's meeting rooms continues to remain steady, with staff fielding a constant stream of inquiries. We hosted two Town of Gray related meetings, and the space was used by five community-based organizations.

In other library news, the Gray Public Library became the first library in Maine to reintroduce a vinyl record collection. The Library continued to augment the general Minerva collection of highly requested items through the Minerva High Demand Library, a Minerva funded project which seeks to add additional copies of high demand items to decrease the time it takes for patrons to receive requested books. Began conversation with other library catalogers about creating a process for libraries to submit and implement new material types in the catalog, so terms describing items in the catalog are closer to commonly used, as opposed to specialized and esoteric terms. The library promoted, and received very positive feedback, from the community regarding the move to a "fine free" policy. So far, there has been no increase in items held longer than due date, nor kept out long enough to be billed.

For Communications and IT, the Departments took part in a debriefing that explained the role of the two departments in the overall operations of the Town. I worked with the Communications Department in preparation of learning the broadcast techniques for GCTV and will soon buttress my knowledge so essential functions can be replicated. The same is true for the IT department.

Information Technology Details

Server was updated from July 12 to July 15, 2022.

George from Code Office had a fatal computer crash, resulting in need to identify a new terminal for him to use on July 15.

36 calls were received for assistance from Helpdesk.

Started building and replacing computers, starting July 21st and ongoing through August.

The below chart is a week-by-week breakdown of email threats:

Weekly Statistics

Month	Type	Count	Size	Percent
7/18/2022	Valid	4,058	642.15 MB	58.93%
	Spam	2,643	54.2 MB	38.38%
	Virus	185	8.99 MB	2.69%
	Total	6,886	705.35 MB	100%

Month	Type	Count	Size	Percent
7/11/2022	Valid	4,417	646.96 MB	62.55%
	Spam	2,581	44.63 MB	36.55%
	Virus	64	24 MB	0.91%
	Total	7,062	715.59 MB	100%
7/4/2022	Valid	3,701	615.05 MB	63.95%
	Spam	2,020	51.16 MB	34.91%
	Virus	66	1.28 MB	1.14%
	Total	5,787	667.5 MB	100%

For July, 2022, the top email Spam categories were:

Top Spam Categories

Category	Count
SPAMCONTENT	943
Country-Ban	811
Truncated	277
Bulk Mail	248
Phishing	226
Other Spam	119
Blocked Sender	21

For a breakdown of the Communications Department Digital Metrics, please see the enclosed PowerPoint presentation.



TOWN OF GRAY

Henry Pennell Municipal Complex
24 Main St, Gray Maine 04039
www.graymaine.org

PLANNING DEPARTMENT

Doug Webster, Director of Planning
dwebster@graymaine.org
(207) 657-3339

July 28, 2022

Planning Department Report to Town Manager (6/29 – 7/28, 2022):

- Coordinate 7-14 PB workshop with Open Space Committee
- Blueberry Festival: meetings & planning of shortly upcoming event

Town Council Tracking Worksheet Items:

- Village infrastructure meeting on 7-6-22
- Continue coordination with Town consulting engineer re Village infrastructure
- Coordinate/implement with TM & consulting engineer re next steps for Yar. Rd.
- Continued outreach efforts regarding Yarmouth Road consultants for improvements
- Work with consulting engineer re traffic circle study & village planning
- Continued communications/follow-up re LWCF conversion/congressional outreach
- Input and subsequent adjustments to Short Term Rental Ordinance for 8-2 TC first read
- Extensive logistics regarding desired Brown Street temp closure for 7-29 block party
- Attend multiple meetings with town staff re coordinating logistics for block party
- Examples of logistics include: live music, food, banners/signs, drinks, utilities, site layout

Other Activities / Accomplishments:

- Meet with W. Gray Rd. possible business needing traffic movement permit
- Part of interview team for town clerk position on 6-29
- Assist/coordinate property information for Dry Mills owner State appeal
- Help coordinate logistics for 7-27-22 ZBA meeting
- Open space committee meeting attendance & coordinate PB workshop
- Managing PB escrows including returning \$ to applicants for older projects
- Historical recon for past PB subdivision road for pending SD amendment
- Coordinate input regarding Gore Road information request for road association
- On-site with Public Works on Mayberry for reported town drainage issue
- Forward progress on resolving long-stand ISM surety matter inc. on-site meeting
- 6-30 meeting regarding historical background for Blackthorne-former enf. matter

Challenges / Obstacles Requiring Assistance Outside of the Department:

- Very helpful having new CEO on board
- Profound thank you to Kyle, Anthony, Mo, Alec & Abby for help with end July Planning



TOWN OF GRAY

Henry Pennell Municipal Complex
24 Main St, Gray Maine 04039
www.graymaine.org

PUBLIC WORKS

Alec Dodd, Public Works Director
adodd@graymaine.org
(207) 657-3381

July 28, 2022

Public Works Monthly Report to Town Manager (6/27/2022-7/25/2022)

Activities:

- Summer road construction began with rented excavator 7/5.
- Catch basin cleaning, completed 7/11-7/14.
- Roadside mowing and regular maintenance activities ongoing.
- Road markings are nearly complete, road lines are still in progress.
- Multiple heavy rain and windstorms have brought some trees and tree debris down on the roads requiring after hours response and unscheduled cleanup.
- Assisting Historical Society with relocation of granite from area of future addition.

Challenges / Obstacles Requiring Assistance Outside of the Department:

- Village visioning, many challenges with block party and Brown St closure planning. Traffic control plan generated and shared with Public Safety.
- Contractor holdups and weather have hampered efforts to accomplish road markings in a timely manner this season.
- Market conditions and delay in securing financing has resulted in a price increase in excavator purchase.
- Planning with GP for future bridge repairs on McConkey Rd and Totten Rd.
- Coordinate with CEO and others on driveway/private road permit challenges.

Town Council Tracking Worksheet Items:

- Review project areas for Main St/Lewiston Rd and collaborate with MeDOT, planning staff and Principle consultant.
- Review project areas for Yarmouth Rd with Gorrill Palmer and planning staff.



TOWN OF GRAY

Henry Pennell Municipal Complex
24 Main St, Gray Maine 04039
www.graymaine.org

RECREATION DEPARTMENT

Anthony Dahms, Director of Recreation
adahms@graymaine.org
(207) 657-2323

July 25, 2022

Recreation Department Report to Town Manager July 2022:

- 7.11 The Recreation Committee met
- 7.12 Fall Sign ups for Before/After school opened and filled up with registrations
- 7.13 GNG Jr. Track wrapped up with a local track meet and a fun run for the younger participants
- 7.19 Summer camps participated in camp kindness day which included rock painting, letters home to families, supportive signs for the walking group as well as goodie bags for encouragement
- 7.21 Fall programming meeting for GNG Rec
- 7.29 Community Block Party

Other Activities / Accomplishments:

- A lot of time was spent finalizing plans for the community visioning week. Many departments have been working together to make this week happen.
- Wilkies Beach has remained open, weekly testing for E. Coli has been in the safe range. Part time staff member was hired for beach attendant, the beach will now have coverage on most days.
- Hiring for before/after school programs will open soon.
- Kids Club is working with DHHS to become a provider that accepts Child Care Subsidy Program for the before and after school program.
- Continued growth in the Nordic Walking program, many have returned walking poles because they've purchased their own.
- LIT Camp installed the posts for the story walk and put a new book out.

Challenges / Obstacles Requiring Assistance Outside of the Department:

*O/F/C (All)

OPEN

Count of Description	Column Labels			
	H	L	M	Grand Total
Row Labels				
Administrative		2	1	3
Committee	1			1
Comp. Plan Implementation	1			1
Infrastructure	1			1
Infrastructure / Village TIF Goals	1			1
Open Space / Conservation Plan	1		1	2
Ordinance	5	2	10	17
Ordinance /Standards			1	1
Process		1		1
Public Safety			1	1
Recreation			1	1
Residential			1	1
Revenue		1		1
TIF Goal / Budget	1			1
Traffic	2		2	4
Training		1		1
Grand Total	13	7	18	38

*O/F/C (All)

CLOSED

Count of Description	Column Labels				
	-	H	L	M	Grand Total
Row Labels					
Administrative		6	4	6	16
Budget		1		2	3
Budget			2		2
Comp Plan Imp - break out item 84		3			3
Comp. Plan Update		1			1
Comp. Plan Update - breakout of tasks for Item 11		3			3
Comp. Plan Update/ Conservation Plan		1			1
Infrastructure / Village TIF Goals				1	1
Joint Leaders		1		2	3
Ordinance	1	8	1	19	29
Policy				5	5
TIF Goal / Budget		2			2
TIF Goal / Budget - break out tasks from Item 34		1			1
Traffic		2			2
Traffic - MDOT - break out tasks from item 24A				1	1
Traffic - MTA				1	1

Traffic - MTA - break out tasks for Item 24B				1	1
Training				1	1
Grand Total	1	29	7	39	76

*Status: O = Open C = Closed F= Future Priority: **H = 1-3 months M = 4-9 months L = 10+ months - Guideline										Last Update: 06/21/2022		
No	Goal/Category	*O/ F/C	** Prty	P No.	Target Date	Description	Sub by:	Owner:	Assigned to:	Dated Logged	Last Update	Comments
84	Comp. Plan Implementation	O	H	1	Detail Tab	Identify steps/ create plan to implement newly approved Comprehensive plan . SEE SEPARATE TAB - FOR DETAILS	Council	Council	Council	12/01/20	07/05/22	(12/1) Council agreed to close old item and create new implementation plan. Detailed tasks will be logged on detail tab pending schedule workshop to review them and come up with timeline/prioritization. Council agreed with Dan's suggestion to ask each Committee to review CP to ID what would inform their work, how they can support implem, what roadblocks exist, what resources will be needed, etc. with a one page summary due by 2/8 for Council reviewed at 2/16 meeting. Dept heads have reviewed the plan. (12/9) Council discussed further at workshop. (4/19) New volunteer outreach underway. Council reviewed & agreed to GPCOG proposal for Village Planning. See Detail tab for updates . Next Steps: Nate to excute contract with GPCOG.
49	Ordinance	O	H	2	07/01/22	Review current ordinances and zoning to determine if changes are needed for Duplexes	Dan Maguire	Dan Maguire	Doug Webster	02/19/19	03/15/22	Dan asked the Council to consider making changes to Duplexes to address sprawl growth and other unintended impacts to density bonus of allowing a duplex in lieu of a single unit of housing. Doug advised this issue has been researched in the past. Dan needs to talk to Kathy and then work through reviewing current ordinances. Then, bring to the OAC for possible proposal to the Council. (12/17) Deb advised of resident e-mail regarding the number of duplexes being built in Gray - Planning Board has also recently discussed. Council agreed this issue needs to be moved up in the priority list. (6/2) Council reviewed questions from OAC & provided direction. Generally speaking, there was support to make it more restrictive in certain zones and encourage them in others by making it less restrictive. It was agreed this is one tool in the growth mgmt plan. (8/4) Doug provided memo detailing OAC ques/disc points along with the growth plan disc and Comp Plan review. Council agreed a full workshop is needed to review. (9/1) Council disc OAC document cover duplexes, multi unit housing, growth & comp plan info - agreed addt'l workshop to create workplan to complete all the work needed. (5/18) Council approved a moratorium in the Village on single family and dual family housing to allow for the creation of new standards and requirements in those zones (see item #94) (9/7) 1st read of design stand in Village (9/21) 2nd read/hear held by Council (PB held hear 9/20) changes go into effect in 30 days. (10/5) Council/Doug discussed whether this should stay standalone item - likely be swept into changes are they are made - but do not want to lose sight of this critical issue. (3/15) Nate pres plan for PD Staff work to Council. Next Step: Doug's focus will be on zoning/ordinance changes in VC/VCP
34	TIF Goal / Budget	O	H	3	Detail Tab	Work on planning associated with new Village TIF . SEE SEPARATE TAB FOR DETAILS	Council	Nate Rudy	Doug Webster	08/07/18	06/07/22	Councilors agreed to close 'TIF creation' task as it is now in approved. This new item will capture the planning and additional work associated with administrating the new TIF. Project was discussed during 9/10 workshop & Mr. Lavallee advised video work was still outstanding, but felt he would be able to present at 2nd Oct meeting. 9/18 Deb advised that there was still one piece left to complete. Review of MDOT/Town video work & analysis to be presented at Dec 4th meeting (as presentation was delayed from 11/13 meeting). (11/28) Council reviewed updated info on projects with Steve, as well as his priorities. Mixed Use options were discussed at length. (12/4) Will Haskell & MDOT provided updated info on Main Str Project. (2/5) & (2/19) See new detail tab H3. MDOT has advised change in Main Str project timeline. (7/2) Workshop held (8/6) 7/1 Workshop minutes approved. (10/15) Council agreed time to set up another brainstorming session - likely on Route 115 road - agreed to wait until 10/28 workshop to schedule so Bruce would be included. (10/28) Public forum set 12/5. (11/12) Dan will facilitate - Council agreed to set up/format. (6/7) Village Charette planned for last week of July. See detail tab for updates. Next Step: Village Charette set for last week of July.

*Status: O = Open C = Closed F= Future					Priority: **H = 1-3 months M = 4-9 months L = 10+ months - Guideline							
No	Goal/Category	*O/ F/C	** Prty	P No.	Target Date	Description	Sub by:	Owner:	Assigned to:	Dated Logged	Last Update	Comments
22	Ordinance	O	H	4.1	06/01/22	Review current ordinance governing stormwater drainage measurements to determine if updates are needed. Update ordinance to include licensing fee or other fee structure IF business wants access to stormwater system .	Council	Nate Rudy	Doug Webster	02/09/18	03/15/22	During the CZA process with Cumberland Farms, much discussion was centered around "peak flow" vs. "volume" of stormwater drainage & about possibly updating the existing ordinance to cover both measurements. TC discussed and need Staff direction on item, as well as priority/timeline. Doug Webster made presentation (3/6) of feedback from Town Engineer. Recommendation is update ordinance to specify licensing or fee structure to account for any future requests to hook up to Town's stormwater system. (2/5) Council discussed need to move this up to ensure work is done before MDOT comes to redo Main Str and to ensure used in future development proposals. Doug also pointed out that results of Watershed study may impact regulations as stricter state statutes come into play. Study is awaiting Spring field work & will include detail to help. (3/5) OAC provided priority order of outstanding items & this was included. (5/21) OAC had prelim disussion at May meeting. (7/2) OAC started review - will continue at 7/10 meeting. (3/12) Staff recommend stormwater modeling be done to understand current infrastructure and recommendation for future - to anticipate add'l devel. That would inform the ordinance/fee work. (3/15) Nate/Doug adv work is underway with Will to determine scope of analysis and data collection. Next Step: Doug & Will will provide analysis to Council when available.
25	Ordinance	O	H	4.2	06/01/22	Review current ordinance governing stormwater drainage measurements to determine if updates are needed. Create stormwater performance standards for future development in Village and/or for businesses wishing to access Town's stormwater system.	Doug Webster	Nate Rudy	Doug Webster	03/06/18	03/15/22	During the CZA process with Cumberland Farms, much discussion was centered around "peak flow" vs. "volume" of stormwater drainage & about possibly updating the existing ordinance to cover both measurements. TC discussed and need Staff direction on item, as well as priority/timeline. Doug Webster made presentation (3/6) of feedback from Town Engineer. Recommendation is to memorialize Cumberland Farms discussions/approach to be used as a 'performance standard' in conjunction with ordinance for future development. (2/5) Council discussed need to mvoe this up to ensure work is done before MDOT comes to redo Main Str and to ensure used in future development proposals. (10/1) Dan advised OAC felt this one was easy to complete - moved up in priority. (2/4) Dan confirmed the OAC is back to meeting & has agreed to meet every other week to try to catch up. He advised they looked at Solar Overlay & Growth Cap and Duplex but need more guidance on the last. Priorities except for open space were unchanged. (3/15) Tied to item #22 - awaiting analysis/data from Will. Next Step: Doug & Will will provide analysis to Council when available.
103	Infrastructure	O	H	5	TBD	Create Libby Hill Road upgrade Plan including 2nd emergency school exit and sidewalk	Sandy Carder	Nate Rudy	Sandy Carder	12/09/21	06/07/22	(12/9/21) Council has discussed at various times as LH Road is set for repaving, but prefer to upgrade road to address long term needs. Covid issues have worsened student safety issues on this road. MSAD15 has expressed an interest in researching the possibility of utilizing their ROW to Shaker RD via the HS parking lot as an emergency exit to comply with safety plans which require 1 entrance for rescue personnel and another for exit. Extension/upgrade (ADA) of the sidewalk the full length of the road is identified as a critical need. Extension of the Hannaford sidewal to Spruce Street with a lighted crosswalk from Spruce to the ROW is also on the list. MSAD15 has req a formal workshop to begin researching options. (1/18) Sandy adv MSAD15 agreed to workshop to brainstorm project scope (3/28) Joint WS held & scope defined. (4/5) Anne preparing app for earmark funding & Sandy seeking letters of support - deadline is 4/13. (4/19) Anne submitted application with recommendation letters (5/19) Unfortunately, Gray was not selected for the earmark. (6/7) Anne adv MDOT provided some feedback Next Step: Anne will review DOT material & follow up with Rep Pingree's office.

*Status: O = Open C = Closed F= Future					Priority: **H = 1-3 months M = 4-9 months L = 10+ months - Guideline							
No	Goal/Category	*O/ F/C	** Prty	P No.	Target Date	Description	Sub by:	Owner:	Assigned to:	Dated Logged	Last Update	Comments
66B	Traffic	O	H	6	01/31/22	Determine if Time of Day Weight restriction should be placed on Short Shaker Rd.	Sandy Carder	Council	Nate Rudy	11/12/19	07/05/22	(12/3) Sandy provided more info on options incl. weight limits. Deb advised of possible "State Aid" classification. (12/17) Deb provided proposal from G&P - \$1,000 to determine if Mayall/Weymouth would even qualify - Council expressed concerns on impacts to road maintenance and residents. (1/21) After rev expenses & discuss control concerns, Council agreed NOT to pursue state aid status on either road. Can revisit at later date. (10/6) Public forum held with info sharing with regards to Depot Rd (10/20) Council disc options (12/15) Dan & Sandy held discussion. Dan updated Council. (1/5) Dan adv MDOT has sample ord see #77. (2/2) Dan has draft ord/letter. (3/16) Council prov feedback to Dan to update Ord. He will coordinate with Nate to submit to legal. (5/4) Dan req an update on status. (5/18) Legal has rev with feedback. (6/2) Council provided feedback (7/6) Nate adv only 1 call rec'd from letter (9/7) 1st read will be 9/21 with 2nd read 10/5. (9/21) 1st read/public hear held (10/5) 2nd read/hear held - approved for local roads. (12/9) sign lang identified & Council voted to install. (12/21) Council dis next step for short shaker (2/1) Letter sent (3/1) Sandy adv Bruce Van Note req a meet in Gray for 1 hour later this month with Nate/Sandy - Anne will also attend. (3/29) meeting held with DOT (4/19) Council agreed to close Mayall Rd portion. 17/5) Sandy followed up with Dale - he said they think they found some language & will send it along. Next Step: DOT to provide wording for ordinance amendment, Town will hold new public hearings when updated.
4	Traffic	O	H	Z	Detail Tab	Work to develop long term changes needed to address traffic, drainage, road conditions, pedestrian & cyclist safety and speed along Route 115 entering Gray from the hill thru connection to Brown Street.	Nate Rudy	Council	Nate Rudy	01/02/18	06/07/22	During the June Council meeting, Town Staff advised they would be pursuing a MPI grant for reconstruction of this stretch of road in collaboration with the MDOT. It was advised it would likely be a 2 year process with updates provided to the Council. Deb Cabana noted that this would be a 50/50 split for costs (not 25/75 Town/MDOT as previously stated) and includes replacement of the water main. Therefore, it may be included in the upcoming TIF creation, thus it should remain active (rather than 2 year target). Reference material: Pavement Conditions Study - Dec 2017. Project discussed in 9/10 & 11/28 TIF workshops, as well as in TC meetings. (12/4) TC would like to see a review of intersections done prior to committing to a 115 solution or as part of the engineering of that project - to ensure project does not hamstring options. (5/7) Deb advised several communications received regarding pedestrian fatality on Rt 115 requesting sidewalks. (9/3) Sandy adv of outstanding question - need for possible budget consideration (9/17) Deb verified with Will that MPI does not require engineering completion - however - Ann verified the Town's piece of the budget must be approved & set aside to apply. Dan also advised a 50+ sub division (apartment buildings) is before the PB for this road & stormwater/sidewalks are being discussed. (10/15) Deb adv Stevie/Will met with DOT & have more info. (10/28) Council set up public forum 12/5. (11/12) Dan will facilitate & council discussed format. (12/5) Public Forum held. (12/17) Council agreed 1st forum very successful, data compiled, next step is to work out starting point on proj. (1/21) Council held workshp with Water Distr about Route 100 TIF and this proj was select by both grps as the best proj. (2/4) Deb adv Alyssa said it is possible to amend rt 100 TIF for this proj but needs to talk details with us. (3/10) Council & WD agreed to amend TIF to incl this proj (4/28) Council rev warrant art (6/2) Council held public hearing & voted to approval TIF amend (7/21) Voters approved revision. (10/6) State submission done. (12/1) TIF amend appr. (1/19) Council agreed with Water Dist/Will on first tasks to start process. (3/2) Will prov est. (9/7) Council set up 'kick off' meet date with prime parties. See Detail Tab for updates (9/27) Kick off meet held - next steps set (6/7) Village charette planned end of July & TIF funds for easement work in budget. Next Step: New tasks logged on detail sheet.

*Status: O = Open C = Closed F= Future					Priority: **H = 1-3 months M = 4-9 months L = 10+ months - Guideline							
No	Goal/Category	*O/ F/C	** Prty	P No.	Target Date	Description	Sub by:	Owner:	Assigned to:	Dated Logged	Last Update	Comments
89	Infrastructure / Village TIF Goals	O	H	8	Detail Tab	Create Engineering Plans for Main Street and Coordinate with MDOT for construction	Council	Council	Nate Rudy	02/19/19	06/07/22	MDOT has agree to cov the upgrade of stormwater & catch basins Main Street & down 202 towards the Cemetery. They adv the plan will likely come up in the next 5-7 years. Town needs to id any other chges- increas water line size, increas stormwater line size, add conduit for underground utilities, add piping for natural gas so funding can be budg & all items add at the same time (rip the road up once). (4/2) Doug prov 8-12 year window for work on Main as guide for Council meaning analysis & plan should be done well beforehand. (4/16) MDOT adv the timeline for this proj is being moved up. Council agr to move up in priority at 5/7 meet & set a stand alone TIF workshop. Workshop held 7/2. (8/6) Min from 7/2 workshop appr. Council to set up another TIF workshop. (7/21) Council had workshop with MDOT & learned portion of road may be worked on in separate project for which engineering is underway. Await more info from MDOT. (9/1) Village walkabout was done with Patrick Adams MDOT, Water District, and others to identify issues/solutions. Rob Betz is coordinating with Ernie Harris on current project from Town line to Cumby's. Council followed up to determine scope of 2nd project from MTA interchange to Brown Street? Can orphan piece be added to that project? (2/16) Council agr to move to open list. (4/6) Nate & Alec had a walk thru with Rob where he adv phase 1 is moving forward, but phase 2 will now only include stormwater NOT a reconstruction of the road. Alec adv that the road is in terrible condition which cannot be adressed with an overlay. Council met with Water District and agreed Village TIF fund needs to be avail in coming year for planning. (5/4) Council incl \$75k TIF funds in budget (6/15) MDOT Rob Betz attend workshop and advised both projects are fund with 2023 construct projection. (9/7) Council will hold WS on 9/15 to complete their prep for MDOT meet (9/21) MDOT WS held - timelines work discussed. (4/19) Council rev plan/fund options provided by DOT & chose to remain in current workplan timeline. Nate will communicate. Next Steps: Village Charette <u>dates finalized</u>. New tasks logged on detail tab.
104	Ordinance	O	H	9	06/01/22	Correct Self Storage Ordinance and create restrictions on new facilities	Doug Webster	Nate Rudy	Doug Webster	01/05/22	06/07/22	(12/21/21) Doug brought 2 issues to the Council which came up via a Planning Board review of 2 pending applications. (1) limit to 1 building and (2) should outdoor storage be allowed? Both were inadvertently overlooked when the ordinance was worked on last. The first one is impacting the active applications. Councilors raised issues with the number of self storage facilities being built in Gray. (1/5) Council reviewed in more detail and agreed to (1) update to existing ordinance to address 2 points raised (2) moratorium on self storage units which does not impact the 2 active applications and (3) proposals from PD on options to limit additional self storage facilities.(2/1) 1st read/public hearing held on both ordinance change & moratorium. (2/14) 2nd read & public hear held - Council appr (4/19) Nate adv larger changes in progress. Could be ready by June. (5/19) Self Storage moratorium was extended. Council provided feedback. (6/7) Dan adv OAC discussed and provided feedback to Staff. Next Step: Doug/Kristen to incorporate feedback and bring back for 2nd discussion.

*Status: O = Open C = Closed F= Future					Priority: **H = 1-3 months M = 4-9 months L = 10+ months - Guideline							
No	Goal/Category	*O/ F/C	** Prty	P No.	Target Date	Description	Sub by:	Owner:	Assigned to:	Dated Logged	Last Update	Comments
92	Open Space / Conservation Plan	O	H	10	12/01/22	Resolve State Land for Maine's Future Grant Conversion issue created by the Tennis Courts	Council	Nate Rudy	Kristen Muszynski	04/06/21	04/05/22	(4/6/21) Tennis Courts were built at the GNG HS back using a Land for Maine's Future Grant. Back in 2006, MSAD15 removed the tennis courts (after notifying the Town) to expand their parking lot. This was a violation of the grant program which requires the recreational space created remain conserved forever. Until the space is 'converted' into another space, the Town cannot accept or apply for additional grant funding. This grant program is the primary program in the State for purchasing and conserving open space. The Council has approved a Contract Zone Agreement for Stillwater Subdivision located on Woodcock which includes the donation of 12.9 acres of land to be used as recreational space. Doug Beck, who is handling the conversion issue, advised this would be a qualifying property. The process to approve the conversion requires the Federal Gov and can take up to 3 years. Doug B adv once the Town demonstrates a real effort towards the conversion, he can release the hold on the grant program. (7/6) Nate discussed with Doug Beck & had information on next steps. (9/21) Sandy adv checklist rec'd and Town must submit documentation to get ball rolling (10/5) Anne completed draft of paperwok. Doug advise it was sent today. (12/7) Kristin prov update from site walk with Doug Beck who identified a possible issue with the road ownership. She confirmed items 1-5 on the check list are complete. Council also agreed to approach MSAD15 to share costs of appraisals. (4/5) Kristen prov update that app has been submitted to Nat'l Park Service but person who reviews it retired & position has not been filled. Next Step: Kristen & Doug to provide more info on the road to Doug B so he may submit to Feds (item 6), Council to budget for yellow book/envir study(item 7).
111	Ordinance	O	H	11	06/01/22	Create Short Term Rental Ordinance and/or program in collaboration with ADU ordinances	Nate Rudy	Nate Rudy	Kristen Muszynski	03/15/22	06/21/22	(03/15/2022) Nate advised that Staff has prepared a couple options for the Council consideration. It is critical Gray put something on the books given the State's current work on ADU housing - namely allowing ADU at every single family home without regard to local zoning. Having something on the books could allow Gray more control/flexibility with possible upcoming changes. Gray also does not have a list of existing ADU or Short Term rentals. (4/5) Doug presented 2 options to Council & Council selected option 2 with some feedback. (4/19) LD2003 has passed - will need to log new item to cover and address ADU as a separate sub-item. (5/3) Council reviewed updated draft along with legal updates and outstanding questions. Provided feedback, but also requested clarification on a few points. (5/19) Council reviewed again & provided more feedback based on Alyssa's responses. (6/21) Nate adv there are some issues with shoreland zoning still being discussed with Alyssa. Too late to have 1st read at the 7/5 meeting - set for Aug. Next Step: Doug to incorporate changes and set up for 1st reading.
115	Committee	O	H	12	08/01/22	Update Ordinance Advisory Committee Duties	Council	Nate Rudy	Nate Rudy	05/19/22	05/19/22	(05/19/22) Council discussed history of OAC and current status. Everyone agreed the effectiveness of the Committee was impacted by Staffing issues, the adoption of the new Comp Plan, changing priorities and a focus on ordinance work. Suggestion was made that the OAC is still advisory - but to whom - the Council or Staff. There was consensus that the use of the OAC would vary depending the situation - size of ordinance change, urgency and if other resources were available (interns). There was also discussion of having the OAC do other projects, like reviewing all ordinances to standardize the format, content and clauses/fees. There was consensus that perhaps a consultant may be needed for that size project. Council agreed that Nate/Staff need to draft new duties and then meet with the OAC to discuss before coming back to the Council. Next Step: Nate/Staff to draft new duties.

*Status: O = Open C = Closed F= Future					Priority: **H = 1-3 months M = 4-9 months L = 10+ months - Guideline							
No	Goal/Category	*O/ F/C	** Prty	P No.	Target Date	Description	Sub by:	Owner:	Assigned to:	Dated Logged	Last Update	Comments
24A	Traffic	O	M	1.1	Detail Tab	Based on TC meeting with State Representatives and Senator, identify action items to pursue both short term & long term. We will keep NG informed of our meetings/progress so they may attend, if they chose. MDOT Portion. SEE SEPARATE TAB - FOR DETAILS	Council	Council	Sandy Carder	02/22/18	04/05/22	Councilor Carder created meeting notes from Workshop (1/29), Councilor Foshay pulled action items to create list. Logging working list item to capture review/prioritization effort by Council. New individual items will be logged as needed. Council discussed at 3/6 meeting & agreed to set up separate meetings with MTA/MDOT - with a target date of end of April/beginning of May - MDOT - prior to a TC meeting 5:30pm start time. That will allow 90 minutes to discuss. TC agreed signage - (1) old Rt26 vs by-pass (2) in Village around island (no sign again) (3) Depot Rd RR Xing would be priority 1. Kyle also advised he will look into signage (1) & (2). Deb requested target date & CC State Reps/Senator. Deb spoke to MDOT advising of RT 26 bridge closure - suggesting it may be a good time to consider renaming Route 26. Deb advised a MDOT/Staff meeting was held (1) traffic movement permit at 97 shaker (2) closing shaker rd bridge MTA work (3) village island (4) rt 26 routing were discussed. (12/4) MDOT provided some info at Council meeting. (3/5) Sandy pulled down new workplan & sent to Councilors. (6/16) Rob Betz, Patrick Adams & Steve Cole from the MDOT attended a workshop with the Council to review various projects in process, in planning & on the future list. Patrick offered to come to Gray to do a walkthrough of all the various streets to obtain more information on the issues. (7/21) Walkthru set up 8/5. (12/7) Island item moved to Main Street detail tab. Next Step: See Detail tab for more info.
24B	Traffic	O	M	1.2	Detail Tab	Based on TC meeting with State Representatives and Senator, identify action items to pursue both short term & long term. We will keep NG informed of our meetings/progress so they may attend, if they chose. MTA Portion. SEE SEPARATE TAB - FOR DETAILS	Council	Council	Sandy Carder	02/22/18	05/18/21	Councilor Carder created meeting notes from Workshop (1/29), Councilor Foshay pulled action items to create list. Logging working list item to capture review/prioritization effort by Council. New individual items will be logged as needed. Council discussed at 3/6 meeting & agreed to set up separate meetings with MTA/MDOT - with a target date of end of April/beginning of May - MTA - set up workshop in May - Peter Mills, Bruce Van Note - to open discussions based on Bruce's list. Added Dan's items - revenue sharing, gifting property & dual access curb cuts. Meeting held Mary 24th. See separate tab for details. Deb requested update and MTA has sent back initial feedback. Council discussed feedback & add'l info from Deb. Discussed possibly sending official letters to individual trucking companies regarding avoiding Village rt26, concerns from MTA about trucks not seeing 'closure' signs and diversion study next steps. Councilor Maguire suggested inviting a MTA planner to future meetings. (12/4) MTA provided info on diversion study (5/4) Nate spoke to Mr. Mills & Erin at MTA Next Step: Awaiting guidance from Legislative team. See detail tab for more info.

*Status: O = Open C = Closed F= Future						Priority: **H = 1-3 months M = 4-9 months L = 10+ months - Guideline						
No	Goal/Category	*O/ F/C	** Prty	P No.	Target Date	Description	Sub by:	Owner:	Assigned to:	Dated Logged	Last Update	Comments
27	Open Space / Conservation Plan	O	M	2	11/01/22	During the Libby Hill Trails clean-up after the October storm, the Community Endowment communicated concerns regarding the longevity of the current ad hoc agreements used to create Libby Hill Trails . Council agreed a full review and updates are needed to protect this asset as part of Open Space Plan .	Sandy Carder	Nate Rudy	Sandy Carder	03/20/18	04/05/22	TC discussed at 3/20 meeting based on feedback received from Community Endowment. Deb advised the agreements just 'came together' and are in need of review/update. Deed research - who has access to which pieces of land, how large of an geographic area is involved, how deep does the research need to go, consultation from a conservation expert - will all be needed and cost money. Council agreed to log with a target of year end, for Staff to review & determine what is needed with an estimated cost, for consideration in next year's budget. Carl Holmquist is willing to provide some names of conservation experts who can assist the Town. (12/20) Issue came up in Open Space Staff meeting - Deb working on pulling together cost estimate for budget meetings. (2/5) TC agreed to move up & tie to H2.1 Open Space. (3/21) est provided at budget meeting. Council agreed to add to budget. (6/11) Residents approved budget. (10/15) Community Endowment has requested an info sharing meeting with Town Staff, 1 Councilor and an MSAD representative to start process of long term maintenance agreement. Council appointed Dan to attend. (11/12) 1st meeting went very well - 3 parties agreed preserving is paramount. (12/3) Council agreed to add annual maintenance to budget spreadsheet. (12/17) 2nd meet focused on budget - MSAD 15 conducting full audit of usage to determine impact - some easement discussion. (1/21) Deb followed up with MSAD15. No update. (2/4) Carl present to School board this week, Craig has some initial data on usage (3/10) Meet held to continue discussion - working through maintenance/budget needs. Council agreed to add the Homestead Acres issues submitted by residents on this private road - to ensure we keep them in the loop as the agreement moves forward. (6/16) Deb will check with Dr. King on next meeting after the election.(8/4) Dan adv MSAD15 lawyer provided framework agreement for review. (10/6) Dan shared a worksheet created to gather input from stakeholders. Council provided gen feedback on form. (10/20) Council prov feedback on worksheet (10/22) Meeting held to compile worksheet info. (1/19) Dan provided summary of MSAD analysis of agreement & advised Attorney is working on drafting an agreement. (2/16) Dan prov an update. Deb adv sub group has met to discuss maint/budg agree (7/6) Draft agree done - Sandy work with entities to finalize outstanding items (9/21) Sandy prov upd from meet (10/5) MSAD has prov initial feedback (11/16) Sandy met with MSAD/GCE (12/7) Council signed off on MOU. (12/21) Council appr MOU (1/18) Sandy adv school board has approved (4/5) Update agree drafted & initial deed feedback Next Step: Sandy to review documents & discuss with Nate/Alyssa. Also researching insurance/liability issue.
99	Ordinance	O	M	3	K1	Create Water Quality (Shoreland) Ordinance	Pam Wilkinson	Nate Rudy	Kristen Muszynski	11/16/21	04/19/22	(10/19/2021) Pam Wilkerson, President of Little Sebago Lakes Association made a presentation to the Council on behalf of the Lake Coalition which includes LSL, Crystal Lake and Forest Lake. They are requesting that the Town create a new ordinance to match the one passed in Windham to protect the water quality of the Town's Lakes. All three lakes are on the 'imperiled' State list. (11/16) Council agreed to proceed and log on our workplan. Sandy also advised that Pam was willing to create a draft to get the ball rolling - she will follow up. (03/15) Sandy adv that Pam Wilkinson is working on mocking up the Windham ordinance to provide as a starting point. She has not rec'd an update lately. (4/5) Nate presented proposal to shift some water shed money to work on this issue. Council had a couple questions related to the testing that would stop at Thayer Brook. (4/19) Lake coalition sub updated Windham ordinance with Gray specifics - Sandy forwarded to Nate to discuss with PS in conjunction with new contract proposal. Next Step: Doug will refer question to CCSW

*Status: O = Open C = Closed F= Future					Priority: **H = 1-3 months M = 4-9 months L = 10+ months - Guideline							
No	Goal/Category	*O/ F/C	** Prty	P No.	Target Date	Description	Sub by:	Owner:	Assigned to:	Dated Logged	Last Update	Comments
69	Recreation	O	M	4	04/01/22	Create a Pocket Park including Historical Marker at 5 Yarmouth Rd property	CEDC	Nate Rudy	Nate Rudy	12/17/19	06/21/22	(12/17) CEDC representative Rachel Rumson presented plans for a new Pocket Park on the 5 Yarmouth Rd municipal property which would include a Historic Marker as part of a Historical Trail - which was presented by Galen Morrison. Council provided some initial feedback. Kathy Tombarelli advised there was a possible grant that may assist with phase 1 of the project - earthwork. (1/7) Kathy provided a draft grant application at meeting and Council provided feedback. Council agreed to add to tracking list as project is ongoing and will involve Town Staff and funding. (1/21) Council approved CDGB application. (3/10) Kathy advised the grant was recommended for funding & is moving onto the next phase. (4/21) Kathy will follow up on status of process. (7/21) Planning board reviewed & were very supportive. Abutter meeting held with great feedback. Council approved Rachel Rumson as agent for Planning board work. Due to LD1 failure, grant funding now on hold. (9/1) Council discussed changes to Committee policy to address consultant work. (9/15) Council approved consultant changes to Committee rules (11/17) Council appr land exchange on site to clarify property line. (1/5) RFP has been posted. (1/19) Council approved 1 proposal rec'd. (2/2) Bruce adv a public forum was held to obtain Community input.(3/2/21) Bruce adv CEDC is working on name and bird house project and planning for Spring work. Alec adv he did some earth work in the Fall and is set to do add'l work in the Spring. The project did receive preliminary approval contingent on one sign off. (4/6) Council approv wood donation from Maschino's Lumber. (4/20) Council app picnic table donations from Aroma Joe's. Kathy adv park has PB appr (5/18) Permablitz was held & work session to lay brick. (6/1) CEDC prov update presentation and recommended name which Council approved. (9/7) 2nd Permablitz set for 9/11 (9/21) Council appr add'l exp for admin of the grant (in Kathy's absence)(2/14) CEDC adv most of grant fund spent (6/21) Krista adv work is nearly complete. Next Step: CEDC work on proposal for maintaining going forward.
105	Ordinance	O	M	5	07/01/22	Update Agritourism Ordinance to address changes in industry & markets	Krista Chappell	Krista Chappell	Krista Chappell	01/04/22	04/05/22	(1/4/2022) Krista reviewed a proposal from the CEDC to update the Agritourism ordinance with several letters from Gray small agri-businesses in Gray. The ordinance was originally drafted for a specific location and requires a great deal of land 50 acres. That business was never built and since that time homestead farms, argribusiness farms, etc. have been growing in Maine & Gray. CEDC/residents feel changes are needed to help encourage continued growth in this economic driver and to be more flexible with new approaches - like permaculture which takes far less space. (3/1) Krista adv CEDC is setting up public forum to review changes residents may want to see. (3/15) Krista advised CEDC holding public forum on 3/16. (4/5) Krista adv public forum was not well attended, but did have good conversation with those there. Next Step: CEDC to make proposal to Council.
55	Administrative	O	M	6	Ongoing	Review current legal agreement between MDOT, Water District and Town regarding the Route 26A winter maintenance and wellhead monitoring	Deb Cabana	Nate Rudy	Nate Rudy	04/16/19	06/07/22	The MDOT has advised they intent to "NOT" renew the legal contract binding them to provide winter maintenance and wellhead monitoring on the Route 26A and wish to turn those responsibilities to the Town. Deb also advised that the last round of MDOT testing found elevated salt level in the testing wells. The current agreement clearly states the MDOT is responsible for addressing those elevated levels; however, they are disputing the cause. (9/3) Executive session held (12/17) add'l Executive session held - Council took no action. (2/17) Council discussed in Ex. Session (3/9) Water Conditions study request submitted via budget process. (7/6) Voters approved budget (11/16) Doug prov update - delay is due to identifying the best party to conduct study. WD has been consluded. Council voted to carryover funds. (2/14) Nate adv receipt of WD letter & that a plan of action has been worked up. (6/7) Nate & Sandy rec'd letter from WD Next Steps: Nate working with staff to update WD and schedule next work.

*Status: O = Open C = Closed F= Future					Priority: **H = 1-3 months M = 4-9 months L = 10+ months - Guideline							
No	Goal/Category	*O/ F/C	** Prty	P No.	Target Date	Description	Sub by:	Owner:	Assigned to:	Dated Logged	Last Update	Comments
70	Ordinance	O	M	7	D1	Review current residential Subdivision Ordinance for necessary changes in Open Space	Doug Webster	Nate Rudy	Doug Webster	02/04/20	04/19/22	(2/5) Doug advised there were some critical issues that needed review within the current residential Subdivision ordinance.(3/5) OAC provided priority order of Outstanding items & this was included. Also, identified "Fire Protection" adjustments and Open Space standards as items to be worked on. (7/2) OAC set for 7/10 & this is on agenda. (2/4) Originally logged as Item 40 - Council agreed to split out the OPEN SPACE portion fo the subdivision ordinance as a higher priority. Currently, developers are able to ID & use 'unusable' property as open space to meet the standard to obtain the density bonuses. Ordinance needs to be updated to require the space meet OS standards to count towards density. (3/15) Doug will work on this as part of his VC/VCP review along with GPCOG's work on master plan. It is secondary to the growth Mgmt/multifamily housing work - but connected. (4/19) Anne adv the Open Space Committee has req a meeting with the Planning Board and this is one of their top items. They are willing to take a look at what is currently there and come up with some suggestions on the changes. Next Step: Doug to work on proposed changes.
67	Residential	O	M	8	06/01/22	To review the status Deer Acres property (private road)	Residents	Council	Council	12/03/19	06/06/22	(11/12/19) A group of residents gave a presentation to the Council regarding the current state of their private road - Deer Acres. The road is not actually a deeded private road, but private property with easements. The residents feel the road has been severely impacted by the status of Gore Rd, and the fact that it is used as a connector between Gore Rd and Lyons Point Rd. They are seeking a workshop with the Council to discuss further and develop possible options for solutions. (12/3) The Council expressed serious concerns with taking over a private road, but felt there could be other solutions and they needed more information. They agree to a workshop. (12/17) Bruce advised residents will not be ready to talk until at least April when seasonal residents arrive back in State. (10/6) Council recognized that the residents may be leaving for their winter homes and will push this forward until next spring. (7/6) The window to discuss this has passed again this calendar year. (10/5) Sandy adv group will do presentation at 11/16 Council meeting after Council agreed to presentation in the 9/21 meeting (11/16) Group presented info to Council and answered questions. Nate later advised Staff would like to talk about road ordinance in general with recommended changes to reduce or eliminate addtl winter maintenance additions either temporarily or permanently. Sandy adv another road (Ramsdell) is now seeking a change so Town can do winter maintenance on addtl road being built. (12/7) Nate has req a larger conversation regarding road acceptance & winter maintenance. (4/19) Sandy adv this will likely be scheduled for one of the May workshops. (5/3) Assoc followed up on status. (6/6) Council held WS to discuss road standard issues, winter maintenance policy & costs and any addtl info needed on Deer Acre request. Next Step: Staff to provide recommendations on changes to current policies, pull data from surrounding Towns and provide more information on Deer Acres e-mail from resident. Another workshop will be scheduled once material is ready.
93	Public Safety	O	M	9	K2	Address dilapidated Vacant Buildings around Shaker Rd/No. Raymond Rd intersection	Council	Nate Rudy	Kristen Muszynski	09/01/20	03/15/22	(9/1/20) Council identified dilapidated vacant buildings around Shaker Rd/No. Raymond Rd need to be addressed as the MDOT will not be taking the structures done. (1/5/21) Deb/PD Staff reached out to the property owners. They recognized something needs to be done with the structures and property. They are wondering if zoning changes may be allowed to assist them with redeveloping the properties. PD Staff strongly encouraged new surveys be done first. (5/18) Sandy rec'd complaint from resident on status. (3/15) Nate pres plan for PD Staff work to Council. Doug advised that this is a complex issue which may involve more 'code' work than ordinance work. Next Step: Kristen will work on after short term rental/ADU, self storage and water quality priorities.

*Status: O = Open C = Closed F= Future Priority: **H = 1-3 months M = 4-9 months L = 10+ months - Guideline													Last Update: 06/21/2022
No	Goal/Category	*O/ F/C	** Prty	P No.	Target Date	Description	Sub by:	Owner:	Assigned to:	Dated Logged	Last Update	Comments	
52	Ordinance	O	M	10	05/01/22	Develop local level Sidewalk Construction standards	Dan Maguire	Dan Maguire	Doug Webster	03/05/19	05/19/22	Dan brought up the possible need for local level construction standards for sidewalks after various discussions about status of existing or proposed sidewalks in budget & council meetings. (9/1) Anne provided Council with a "Green Streets Guide" shared by Lauren Meeks (Resident - MDOT engineer) who suggested it be considered when creating our sidewalk standards and during our infrastructure project planning. Dan suggested Lauren attend an OAC meeting in the future. (3/15) Nate adv OAC has discussed & PD Staff have proposals to use template options. (5/19) Doug provided template example which will be used to create options which will be dependent on the type of road, location, traffic, etc. Council provided feedback and suggested a "trail" option also be created. Next Step: Staff to incorporate feedback and create options.	
76	Ordinance	O	M	11	D2	Amend Subdivision Ordinance to strengthen Buffer Zone requirements & provide more autonomy to PB relating to internal roads	Dan Maguire	Nate Rudy	Dan Maguire	05/05/20	05/05/20	(5/5) Based on feedback from the Planning Board regarding the current Buffer Zone requirement being reduced from the 50 foot mandate due to the location of houses and other issues, they are asking the Council to strengthen the language in the ordinance. In addition, they would like more autonomy related to mandating internal roads vs shared driveways to reduce curbcuts and assist with the buffer zone issue. Council agreed to log. Next Step: Dan to bring to the OAC for discussion.	
78	Ordinance	O	M	12	Contract	Create Stormwater Standards for Watersheds	Doug Webster	Nate Rudy	Doug Webster	06/02/20	03/15/22	(6/2) Council agreed to log new item to create Stormwater standards for watersheds which will consist of (1) obtaining assistance from Cumberland County Soil & Water Conservation District (2) consideration of watershed overlay to zoning map (3) setting up add'l peer reviews for PB applications (4) creating ongoing stormwater maintenance inspections/verifications (5) creating procedure to document agreements to bind future owners to maintaining stormwater plans. (3/15) Nate pres plan for PD staff work which included contracting out some of this work. Next Step: Doug to work with CCS&W.	
113	Ordinance	O	M	13	TBD	Create ordinance to restrict herbicides, pesticides and fertilizer use around solar arrays & other sensitive areas (watersheds, public spaces, etc.)	Dan Maguire	Nate Rudy	TBD	05/03/22	06/21/22	(05/03/22) Council agreed this was an important item that should be addressed in the coming year. Initially, adding restrictions for the solar arrays in Town and then add as part of the watershed/shoreland protection discussion. Finally, review other areas this may apply like public parks. (6/21) Council discussed invasive species and State statutes as well as construction projects. Council agreed this will not be worked on until at least the Fall and that working in phases made sense - ie - starting with solar arrays. Next Step: Work on when resources become available.	
94	Ordinance	O	M	14	K3	Update Town's Ordinance to reflect long term Solar Array policies for residential , all sizes.	Deb Cabana	Nate Rudy	Kristen Muszynski	04/20/21	03/15/22	(4/20/2021) Council finalized latest update to the Commercial Solar Overlay District Ordinance. This item is being logged to track the work needed on Residential Solar Array. (3/15) Nate pres plan for PD Staff work. Kristen will take this one over. Next Step: Kristen will work on after higher priority items.	
44	Ordinance	O	M	15	D3	Review current residential Subdivision Ordinance for necessary changes all other areas (besides Open Space - see item 70)	Doug Webster	Nate Rudy	Doug Webster	02/05/19	03/15/22	(2/5) Doug advised there were some critical issues that needed review within the current residential Subdivision ordinance.(3/5) OAC provided priority order of outstanding items & this was included. Also, identified "Fire Protection" adjustments and Open Space standards as items to be worked on. (7/2) OAC set for 7/10 & this is on agenda. (2/4) Council agreed to split out Open Space (see Item 70) to make a higher priority from other changes needed in ordinance. (3/15) Nate pres plan for PD Staff to Council. Next Step: Doug will work on this one after higher priorities.	
106	Ordinance /Standards	O	M	16	TBD	Create a Dark Skies Ordinance or imbed Dark Skies standards in other ordinances	Dan Maguire	TBD	TBD	01/04/22	04/19/22	(1/4/2022) Dan provided information related to the Dark Skies initiative to Council. Council agreed this has validity and is important given the level of infrastructure planning planned in the coming year as well as the work implementing the Comp Plan. No clear approach was defined, but Council agreed this topic needs to be raised as the above work moves forward. (4/19) Council agreed to add sub tasks under big projects to ensure this is considered in planning. Next Step: Define path forward as more discussions are held.	

*Status: O = Open C = Closed F= Future					Priority: **H = 1-3 months M = 4-9 months L = 10+ months - Guideline							
No	Goal/Category	*O/ F/C	** Prty	P No.	Target Date	Description	Sub by:	Owner:	Assigned to:	Dated Logged	Last Update	Comments
107	Ordinance	O	M	17	TBD	Create a Fire Safety Impact Fee to fund public fire cisterns	Dan Maguire	TBD	TBD	01/21/22	01/21/22	(1/21/2022) Dan suggested that long term, Gray should consider taking a different approach with fire cisterns which are currently handled within the sub division process. Developers are required to install cisterns under certain circumstances with Public Safety Director review. The quality, consistency and long term maintenance all vary with the Home Association taking over once Developer is done. The concept is to charge an impact fee, create a fire cistern fund and take over the installation and maintenance under Public Safety/Public Works. Council/Fire Chief agreed this approach may be better long term - pending details. Next Step: Work on when time permits.
114	Process	O	L	1	04/01/23	Create long term plan & transition Tracking Spreadsheet	Dan Maguire	Nate Rudy	Nate Rudy	05/19/22	05/19/22	(05/19/22) Council has been discussing transition of Tracking Spreadsheet to (1) possible different application - currently in excel (2) to a new owner (primary) with access for multiple updates (secondary) (3) changing names (4) defining process around the list for years. It now needs to be done in the next year as Sandy will be in her last year of her 2nd term. Next Step: Nate to come up with options to bring to the Council.
98	Ordinance	O	L	2	K4	Review and update Land Bank Commission Ordinance	Sandy Carder	Open Space Committee	Kristen Muszynski	10/19/21	03/15/22	(10/19/2021) While reviewing the Recreation Committee charge, Sandy pointed out the creation of the Committee stemmed from this now outdated Ordinance. In reading the ordinance, much of the roles and responsibilities have been changed, rest with the Open Space Committee or are not relevant anymore. Anne has agreed to bring to the OSC once their work on their Open Space Plan is complete and report back to the Council on recommendations. (3/15) Nate pres plan for PD Staff to Council. This will be assigned to Kristen. Anne pointed out there is already on the books & Open Space may be able to help. Next Step: Kristen to handle after higher priorities.
60	Ordinance	O	L	3	K5	Review current Kennel related ordinances , identify needed changes & update accordingly.	Deb Cabana	Nate Rudy	Kristen Muszynski	06/04/19	03/15/22	(5/21) Council was made aware of issue via OAC meeting update. New Dog Officer has advised of conflicts between current ordinances and general residential practices. Gray also has existing Kennel businesses. There is also a State Statute involved. Everyone agreed identifying fixes to coincide with new licenses would be best way to communicate any changes. (6/4) Council agreed to move down the priority list - using license timeline as guide. (9/3) Dan advised being moved up due to timing for Dog Officer and Dog licenses. (10/1) Dan advised this one is almost complete. (12/3) Sandy suggested the OAC meet without Doug and work on what they can. Council & Deb discussed and agreed to give this approach a try with Doug reviewing work as needed. (3/15) Nate pres plan for PD Staff to Council. This will be assigned to Kristen. Next Step: Kristine to handle after higher priorities.
110	Revenue	O	L	4	08/01/22	Create Legislative Bill to reimburse Commercial Solar Array Property Tax exemption	Council	Nate Rudy	Nate Rudy	03/01/22	03/01/22	(03/01/22): Nate advised that Commercial Solar Arrays were exempted from local property taxes by the Legislature. After additional research, Lauren Asselin (Assessor) and Nate identified program which will allow for 50% reimbursement. Council directed Nate to send letter to Legislative Team urging them to provide the add'l 50% reimbursement knowing the session was already set. Rep. Moriarty advised there was nothing they could do, but provided contact in Maine Revenue Services to start discussion on proposed bill for next session which does not start until Jan 2023. The deadline for bills is late summer/early fall. Next Step: Nate will reach out to contact at MRS.
102	Training	O	L	5	07/01/22	Develop Committee Volunteers training Webinar	Council	Nate Rudy	Nate Rudy	11/20/21	11/20/21	(11/20/2021) Council discussed needed training for new Committee Volunteers and laid out timeline for annual goal/assignment setting meeting for all Committees. Everyone agreed some type of webinar could be created to allow new volunteers to review at their leisure with a review at the annual meeting. Next Step: Nate will work with Staff to create a training webinar.

*Status: O = Open C = Closed F= Future Priority: **H = 1-3 months M = 4-9 months L = 10+ months - Guideline											Last Update: 06/21/2022	
No	Goal/Category	*O/ F/C	** Prty	P No.	Target Date	Description	Sub by:	Owner:	Assigned to:	Dated Logged	Last Update	Comments
87	Administrative	O	L	6	12/01/21	Review current Fee policy for MSAD15, Gray and NG to determine if there is a better reciprocal approach	Sandy Carder	Sandy Carder	Sandy Carder	02/02/21	06/15/21	(2/2) Sandy advised that this issue had been brought up at the last Joint Leaders meeting. A follow up meeting was held on 1/25 with Craig/Diane/Sam of MSAD15. There is a need to track costs and fees by all three entities. MSAD15 also has financial responsibilities that impact both Gray & NG. The issue is front line workers are left dealing with trying to apply fees when working with coaches, residents, staff, etc. which creates conflict as the taxpayers pay all three budgets. There was agreement there may be a better way to deal with fees. (5/4) Sandy adv next joint leaders meeting set for 6/17 & will follow up on status then. Next Step: Diane will set up a meeting with Katy and NG representative to start by reviewing current processes - it was noted due to budget season, this would likely not take place until April.
39a	Administrative	O	L	7	08/01/22	Need to review/renegotiate Cable TV Contract sometime in 2019-2021.	Deb Cabana	Nate Rudy	Jon Hartt	09/18/18	05/03/22	Deb advised she has asked Alissa Tibbetts, Town Attorney, to begin some research & that process can take up to 1 year. She also advised there is at least one resident willing to serve on a Cable TV Committee, if the Council choses to go that route. Council discussed briefly and confirmed either route will require legal review. Dan asked if there was a way for Alissa to provide a snopsis of the process/issues for council to better understand task. Deb advised significant changes have been made at the Federal level which will require more analysis before approach can be determined. (1/8 & 1/22) Feedback presented on item 42 Cable TV ordinance actually fit into the "contract" between parties. Will keep in mind for this item. (6/4) Legislature passed bill to roll back some of the changes (such as channel location, HD broadcast requirement, etc.) Deb advised GPCOG has sent out an RFP for the negotiator for the Towns invovled. There was no interest in a pre-contract meeting. (8/6) Deb advised GPCOG is preparing contract with law firm (only one rec'd but highly qualified). (10/15) Deb/Brad provided updates from the negotiation meeting with GPCOG attorney. (1/7) Council agreed to separate contract and committee into two action items. (9/15) Audit by consultant resulted in identifying monies owed (\$18K+) to Gray. GPCOG est negotiations will begin in the fall. (2/16) Deb adv target for contract is June. Spectrum disputing owed fees. (7/6) Anne adv this is at a standstill (12/7) Anne attended consortium meeting & provide substantial update. (1/4) Anne & Jon prov update on activities. Jon provided comparison between recommended consortium ordinance vs. Gray - Council agreed to move to consortium & provided some feedback. (1/18) Anne adv Bradley Law has meeting with Spectrum to start negotiations (3/1) Council held 1st read & hearing. (3/15) Jon provided add'l info, Council approved ordinance. (5/3) affirmation vote taken to address motion error in 3/15 meeting. Next Step: Nate/Jon to obtain update from Bradley Law on negotiations.

*Status: O = Open C = Closed F= Future Priority: **H = 1-3 months M = 4-9 months L = 10+ months											Last Update: 07/05/22	
No	Goal/Category	*O/ F/C	** Prty	P No.	Target Date	Description	Sub by:	Owner:	Assigned to:	Dated Logged	Last Update	Comments
B	Comp Plan Imp - break out item 84	O	H	1	01/15/22	Consider New Committee to monitor, supervise, ensure Comp Plan implementation proceeds	Council	Council	Dan Maguire/Krista Chappell	12/01/20	07/05/22	(12/1) Council agreed current Committee should be retired as their charge is complete. Will send Thank You letters to Members and advise Council is considering a new Committee to assist with Implementation - asking them to advise if they are interested in continuing on. New Committee needs further discussion. (2/16) Sandy provided info from Windham Committee - hybrid structure. Generally, there was agreement that is the better model than all volunteer. It will be important to have people with know/exper on the committee. Should not set up until Council can give clear charge and goals to committee. Nate wants a chance to talk through options with Planning Dept as they will take leading role. Sandy also adv Windham hired a consultant to assist them. (10/5) Council agreed this needs to be a top priority in coming year (11/20) Council discussed options at retreat which included utilizing new annual meetings for goal setting/Committee assignments and developing a workgroup responsible for accountability to ensure assignments are being worked on. There was no resolution on the size & representation on that workgroup. (1/4) meeting held - Nate/Krista/Dan (1/18) Council rev framework for Committee & provided feedback(2/14) Krista/Dan shared their proposal. Dan to draft outreach memo & share by 21st. Goal to have posted by end of Feb & included in March newsletter. Application deadline will be end of March to coincide with first April meeting packet. (3/15) Dan adv he will work on shortly (4/5) Sandy ask if anyone had feedback on Dan's draft - none. (5/3) Timeline updated apps through 5/30 Council to review at June workshop. (6/7) Sandy asked if Krista/Dan had heard anything on apps (6/21) No apps were rec'd but Sandy rec'd a message from Lacy & she has agreed to apply (7/5) Council appt Lacy & Lisa . Next Steps: Krista & Dan to set up meeting with new coordinators.
E	Comp Plan Imp - break out item 84	O	H	1	01/31/22	Create plan/timeline for Zoning changes & ordinance changes	Council	Council	Nate Rudy/ Doug Webster	12/01/20	06/07/22	(12/1) Council needs to discuss/create a plan/timeline to update Zoning to reflect zones in new plan and determine prioritization to ensure development adheres to new plan. Will be related to Item 46 (Growth Plan) and Item 49 (Duplex changes) for which initial discussions were held, but placed on hold pending Comp Plan approval. (5/18) Council approved moratorium (4/6 eff - 180 days) to allow time for Staff to update standards/ordinances within the Village and Village Center zones. (7/6) Dan adv OAC is working on reviewing the current zoning against the new Com Plan zones with Town Staff and interns. (12/9) Council agreed to have Doug, Nate and Dan met to discuss the timeline/resources needed for the OAC to take a look at the Critical Rural zone and Village zones to determine options for updates as priorities to ensure protection of CR and no more loss of opportunities for appropriate growth in the Village. (2/14) Nate adv Doug has some initial changes related to density for the Village/VC areas ready to go. (3/1) 1st read & public hearing held. Council requested more information be pulled together & was willing to send to PB to obtain their feedback. (3/15) Council discussed feedback and made modifications to approach. Also reviewed Nate's proposal to address full review of zoning & ordinances for VC/VCP which will include Doug's primary focus and engaging GPCOG while moving all other ordinances to Kristen. (4/5) 1st read/public hear held. PB held public hear 4/10. Council held 2nd read/hear 4/19. (6/7) Nate shared dates for Village Charette Next Steps: Village Charette planned for last week of July.

*Status: O = Open C = Closed F = Future					Priority: **H = 1-3 months M = 4-9 months L = 10+ months			Last Update: 07/05/22				
No	Goal/Category	*O/ F/C	** Prty	P No.	Target Date	Description	Sub by:	Owner:	Assigned to:	Dated Logged	Last Update	Comments
46	Ordinance	O	H	1	07/01/22	Develop Growth Management strategy - as part of Comprehensive Planning & to allow needed time for Open Space Planning	Sandy Carder	Nate Rudy	Nate Rudy / Doug Webster	02/05/19	04/19/22	(1/22) Dan adv PD does not feel any addl action is need at this time. Growth Cap was disc & Staff will look into with OAC and bring forw when ready. A growth cap has been disc in var meet for the last yr. Not hav a robust growth plan and/or cap was 1 primary reason the original Comp Plan was not appr. (1/30) During the Open Space forum, Alan & Lucky both strongly encour a growth cap be disc/imple as soon as possible to provide Gray with more time to dev an Open Space plan. In add, issues with current residential Sub-division ord, duplex allow, and limited safeguards against a large scale dev need to be addr. Kathy adv Staff have crunch annual data & Doug adv dev one would be rather straightforward & would be padded to avoid impact wanted eco & residl dev. (2/19) Council agreed this is a top priority now. (3/5) Doug rev steps (1) Verify current comp plan (2) check with legal ord (3) imple verifying data supports number selected & Council prov direction. (6/4) Doug prov some data and Arundul ord (eff in 1977). Council agreed to proceed cautiously. (9/3) Doug adv best 1st step would to discuss possible 'cap' number and process to apply caps. (10/1) Council WS held - guidance prov to Doug. (1/21) Council would like to have some info to discuss by the 2/18 meet given the push on larger devel & Comp Plan process. (2/4) OAC looked at & were not in support - worried about admin of the process impact staff (2/18) Council disc changing approach to be more comp to focus on Growth MANAGEMENT vs just a cap. Need to coordinate with the comp plan timeline as an appr plan is required to enforce growth permit systems. (3/10) OAC began work on this item.(5/5) OAC wants to coord with Comp Plan so work will not start now, however, due to the need for Council work as well, draft options still to be deliv by end of summer to stay in line with CP. (8/4) Council disc at 8/4 WS to confirm a full WS for this along with the duplex/OAC ord list can be disc (9/1) Council disc OAC doc cover duplexes, multi unit housing, growth & comp plan info - agreed addt! WS to create workplan to complete all the work needed. (2/16) Sandy adv Windham has robust grw permit prog that was 1st step after their comp plan.(4/6) Council dis as part of TM goals (5/18) Council/Staff dis in WS - Staff sug step approach to create (12/9) Council disc and develop plan (3/15) Nate pres plan for PD Staff work to Council. (4/19) Council reviewed & agreed to GPCOG village proposal. Agreed to move this item to sub category under comp plan. Next Step: Work on a growth management plan - for permitting - encouraging with bonus permits in growth areas vs. restricting number in critical rural (for example) as part of Village Planning - Comp Plan implementation.

*Status: O = Open C = Closed F = Future Priority: **H = 1-3 months M = 4-9 months L = 10+ months												
No	Goal/Category	*O/ F/C	** Prty	P No.	Target Date	Description	Sub By:	Owner:	Assigned to:	Dated Logged	Last Update	Comments
A	TIF Goal / Budget - break out tasks from Item 34	O	H	3	02/28/22	TIF - Mixed Use Zoning Discussion for Property next to Northbrook	Town Council	Town Council	Doug Webster	01/22/18	12/09/21	(11/28/18) Mixed Use options were discussed at length. Next workshop set for 2/19 6-7pm prior to scheduled TC Meeting. (2/19) Council discussed options and agreed having some type of proposed changes to consider would be helpful. Should focus on Village, but also on large undeveloped piece abutting Northbrook as owners req. inclusion to help develop. Doug will work on. (12/09) Council identified the need to find a parcel that could be set up with mixed used development - such as the parcel included in the Village TIF which may attract a medical facility and/or larger store like Paris Farmers which expressed an interest in having a location in Gray, but could not find a suitable parcel/building.
B	TIF Goal / Budget - break out tasks from Item 34	O	H	3	TBD	TIF - Center Rd / Bridge Redesign	Town Council	Town Council	Town Council	02/18/18	04/19/22	Town to evaluate possible changes to bridge and/or reconfiguration and/or completion of Turnpike Acres - to address Center Rd outlet just below 5 Rd intersection/left turn issues for tractor trailers in Village (possibly part of TIF workshop to determine plans/priorities for Village infrastructure upgrades). MTA advised that Bridge was recently refurbished & widened so there are no immediate plans for more work; however, they remain open to discussion a realignment. (12/4/20) Part of solution to address tractor trailers in the Village is to address inability to make right hand turn from 202 onto route 100 - which includes alternate route - maybe via turnpike acres/center rd bridge. (2/5/21) TC moving to TIF Planning umbrella (2/19) Deb to find out replacement year from MTA. (4/19/22) Council discussed as a possible project for MDOT Village Initiative Program AFTER the Main Street/Yarmouth Rd work is done.
D	TIF Goal / Budget - break out tasks from Item 34	O	H	3	05/01/22	TIF - Evaluation of possible Sewer/Water treatment option for Village	Town Council	Town Council	Nate Rudy	02/05/19	03/15/22	During TIF public forums, a specific piece of property (22 acres) was added to the map as it was considered a good candidate for a future water treatment / sewer facility - due to the soils and location (gravity may eliminate need for pumps). (2/19/19) Deb confirmed TIF funding can be used to purchase property; however, it can only done once a full blown plan is created for usage. TIF funds cannot be used to buy property for recreation purposes. Council to discuss land acquisition CIP at 2/21 budget meeting. Council has agreed to set up a separate question on the warrant articles & will approve those articles at 5/7 meeting. (12/9) Council agreed Staff needs to provide some options for long term solutions - in the short term. (3/15) Nate adv Will & Doug working on collecting data in conjunction with MDOT data.
7	TIF Goal / Budget - break out tasks from Item 34	O	H	3	TBD	Develop possible Special Assessment Fees - handling as part of TIF discussions	Town Council	Deb Cabana	Town Council	01/22/18	02/05/19	The Planning staff provided high level information regarding possible use of a developed Special Assesment Fees which would be collected as part of new development to offset various costs. Council agreed they should be added to the tool box and requested more detailed information be pulled together for consideration. May be handled in conjunction with In Lieu Fees. 9/18 Council discussed reprioritizing, but decided to leave as is. Dan suggested that we identify other Towns using these fees and use their language as a base. (2/5) Council agreed to handle as part of TIF planning. Next Step: Determine when Staff has capacity to work on.
8	TIF Goal / Budget - break out tasks from Item 34	O	H	3	TBD	Develop possible In Lieu Fees - handling as part of TIF discussions	Town Council	Deb Cabana	Town Council	01/22/18	02/05/19	The Planning staff provided high level information regarding possible use of a developed In Lieu Fees which would be collected as part of new development to offset various costs. Council agreed they should be added to the tool box and requested more detailed information be pulled together for consideration. May be handled in conjunction with Special Assessment Fees. (2/5) Council agreed to handle as part of TIF planning. Next Step: Determine when Staff has capacity to work on.

*Status: O = Open C = Closed F = Future Priority: **H = 1-3 months M = 4-9 months L = 10+ months												Last Update: 06/21/22
No	Goal/Category	*O/ F/C	** Prty	P No.	Target Date	Description	Sub By:	Owner:	Assigned to:	Dated Logged	Last Update	Comments
A	Route 115 - break out tasks from Item 4	O	H	8	TBD	Obtain Ledge Map for scope of project	Council	Nate Rudy	Will Haskell	02/16/21	09/27/21	(2/16) Council agreed to split out tab & tasks from 1/19 workshop. Due to the ledge present on the hill, it was agreed a ledge map using radar was needed. (3/2/21) Will has provided est to Nate. (3/9) Council rev with Will. Doug ask that add'l boring on the slope of the road to ensure the ledge is fully identified. Will will update the proposal. (4/6) Will provided update & Council agreed (6/15) Voters appr budget, Council appr contract. (9/27) Will adv testing is underway. If tests results in identification of ledge, than radar mapping will be done. Next Steps: Mapping should be done within a couple weeks.
B	Route 115 - break out tasks from Item 4	O	H	8	TBD	Obtain updated full Survey for scope of project	Council	Nate Rudy	Will Haskell	02/16/21	09/27/21	(2/16) Council agreed to split out tab & tasks from 1/19 workshop. Given there are no easements on this road, it was agreed an updated survey is needed from Main Street to 59 Yarmouth Road. (3/9/21) Will has provided est to Nate & Council reviewed. There were questions about who would conduct the ROW work - see new item MDOT meeting. (4/6) Will provided update & Council agreed (6/15) Voters appr budget, Council appr contract. (9/27) Survey is underway which will include identification of existing wrought & most impacted parcels. Next Steps: Survey should be done within a couple weeks.
C	Route 115 - break out tasks from Item 4	O	H	8	TBD	Draft a High Level Engineering Plan for scope of project	Council	Nate Rudy	Will Haskell	02/16/21	09/27/21	(2/16) Council agreed to split out tab & tasks from 1/19 workshop. Council has asked Will to create a high level 'starting' engineered plan to help facilitate next set of workshops. This plan should include ALL possible options - which can later be dropped depending on scope/costs - such as adding underground stormwater, sidewalks on both sides, Brown street intersection reconfiguration, traffic calming measures, parking on either Yarmouth or Brown (depending on if Brown is made one way or not), Bike lanes, etc. (3/9/21) Will has provided est to Nate and Council discussed. Council agreed to include 2nd sidewalk in plan, but decision on whether to build will be determined on feasibility and costs. Also agreed to remove "full time inspection" costs until later in the project. The decision on part time vs full time will be easier to make once the project scope/complexity is identified. (4/6) Will provided update & Council agreed (6/15) Voters appr budget, Council appr contract. Council recommended WD reach out to Will asap to ensure their inclusion in same engineering effort. Money was allocated for their piece out the \$495k (9/27) Will prov some high level plans req guidance on several items. WD work being done by another engineer at firm. Next Steps: Add'l guidance provided - Will to update plans & provide estimates on costs to determine what may need to be cut before going to the residents.
D	Route 115 - break out tasks from Item 4	O	H	8	TBD	Provide past Traffic Study for Brown Street	Council	Nate Rudy	Will Haskell	02/16/21	04/19/22	(2/16) Council discussed past reviews of making Brown St one way. Will/Kathy/Doug indicated this issue has been looked at a couple times in the past. Will thinks he can dig up the past reports. Consideration is traffic pooling on Route 115, but also ability to prevent large commercial vehicles from using Brown to get to short Shaker (weight limit being pursued). (9/27) Council expressed strong support to making Brown street one way from Main to Yarmouth - to help solve safety issues, speed, heavy truck traffic on Shaker Rd, and parking issues. MDOT has not approved in the past. (4/19) In workshop, Council spoke about MDOT being okay with making Brown a one way and decided running a test this summer in partnership with the DOT and Bicycle Coalition of Maine would be a good way to identify issues and benefits. Alec pointed out that the MTA controls the lights at the big intersection and we should keep them in the loop. Next Steps: Will to research further.

*Status: O = Open C = Closed F = Future Priority: **H = 1-3 months M = 4-9 months L = 10+ months												
No	Goal/Category	*O/ F/C	** Prty	P No.	Target Date	Description	Sub By:	Owner:	Assigned to:	Dated Logged	Last Update	Comments
E	Route 115 - break out tasks from Item 4	O	H	8	TBD	Set up Joint Meeting with MDOT	Council	Nate Rudy	Nate Rudy	03/09/21	06/15/21	(3/9/21) Will recommended we hold a meeting with MDOT as soon as possible in the process. Several items were identified for discussion (1) possible use of Federal funding (2) MPI/funding formula for project (3) ROW work responsibilities - if DOT does or Town (would have to hire specialist to handle). Meeting will include Will so proposal needs to be updated. (5/4) Nate has req a meeting & follow-up - looking for 5/18 workshop but no response to date. (6/15) MDOT Rob Betz atten workshop & adv Town needs to do easement work and then would hand over to MDOT. Doug asked about which method is preferred, Rob adv there is a manual to follow and that the question should be referred to Cathy Rawlings in Property Division. He will obtain more info for us. He also advised that 2022 MPI funding is all allocated. 2023 is next cycle - await engineering plan is a good idea to ensure we have the best figure - once it is set - we are locked in and we can only obtain \$625k from MDOT. He did adv having a "contingency" figure would be good for a project of this size. MPI contracts are usually signed the year before the funding and once signed Town has 36 months to complete project. Next Steps: Town needs to complete more work to prepare for the MPI application.
F	Route 115 - break out tasks from Item 4	O	H	8	TBD	Set up Meeting with Water Department	Council	Nate Rudy	Will Haskell	03/09/21	09/27/21	(3/9/21) Sandy requested that a meeting with the Water District be added to proposal and done early in the process to identify their scope/timeline to allow for coordination. The TIF defines \$495,000 for their water line work in the project. (4/6) Council met with WD to discuss timeline. WD will provide an estimate of the money they will need in the coming 12 months to begin their engineering/planning. Sandy did adv the information is needed in time for the 4/20 warrant article vote. (4/20) Nate prov updated info from WD - Council agreed the WD req for Route 100 TIF funds was fine (under the \$495K) - subsequent discussions will be needed for overage and for the other TIF fund projects. (6/15) WD attend workshop (9/7) Council set WS 9/27 with primaries incl WD Next Steps: Continue to include WD in meetings.
G	Route 115 - break out tasks from Item 4	O	H	8	TBD	Set up Discussion with First Congregational Church	Council	Nate Rudy	Will Haskell	03/09/21	09/27/21	(3/9/21) Anne pointed out there needs to be open discussion with the First Congregational Church on the reconfiguration of Brown Street intersection. We need to ensure they are aware of the proposals and are invited to the meetings (9/27) Council agreed that starting conversation with Church asap was critical to creating plans for public forum. Next Steps: Will will work with Staff to engage the Church to review options for squaring Brown and dealing with their septic system.
H	Route 115 - break out tasks from Item 4	O	H	8	TBD	Identify Blasting impacts from project	Council	Nate Rudy	Will Haskell	03/09/21	03/09/21	(3/9/21) Anne pointed out if there is any blasting involved in this project, the Town will need to work with residents to minimize impacts and ensure damage is not done to their foundations. Will adv whether blasting will be needed is unknown at this point. Next Steps: Blasting will be identified, if applicable, once more work is done on the planning.
I	Route 115 - break out tasks from Item 4	O	H	8	TBD	Schedule Public Forums for property owners and residents	Council	Nate Rudy	Council	09/27/21	09/27/21	(9/27) Council agreed that identifying the most impacted parcels first and holding on site individual meetings was paramount to identifying options for the road. Once that step is done, then holding a larger public forum for all Yarmouth/Brown road residents would be set to review draft plans and obtain feedback. All residents are welcome, but letters will be sent to Yarmouth/Brown residents. Next Steps: Will to identify most impacted parcels.
J	Route 115 - break out tasks from Item 4	O	H	8	TBD	Obtain info on Budget and MDOT MPI fund disbursement rules	Council	Nate Rudy	Nate Rudy Will Haskell	09/27/21	09/27/21	(9/27) Council asked Nate to obtain new projections on how much money will be available in the Route 100 South TIF for this project. Council asked Will to talk to MDOT about how upcoming MPI schedule for the \$625k contribution and when the money would have to be spent if MPI was approved. There was concern that we could miss out on obtaining the funding, but on the flip side, not be ready to spend it given we will need at least a year to obtain easements. MPI funding cannot be used for easements. Next Steps: Will to identify most impacted parcels.

*Status: O = Open C = Closed F = Future										Priority: **H = 1-3 months M = 4-9 months L = 10+ months		Last Update: 06/21/22
No	Goal/Category	*O/ F/C	** Prty	P No.	Target Date	Description	Sub By:	Owner:	Assigned to:	Dated Logged	Last Update	Comments
K	Route 115 - break out tasks from Item 4	O	H	8	TBD	Identify Firm to complete Easement Work	Will Haskell	Nate Rudy	Nate Rudy Will Haskell	09/27/21	06/21/22	(9/27) With MDOT advising they will not work on easement issues, Will adv his firm does not do that type of work. He has some names he can provide. We will need to obtain estimates so TIF money can be set aside and an RPF can be done. (3/15) Council discussed need to move TIF funds into FY23 budget to ensure easement work can proceed. Council also needs further clarification on WD portion of TIF funds. (6/21) \$500k in TIF money was moved to active in budget approved by Voters. Next Steps: RPF to be created to identify firm to start work.
L	Route 115 - break out tasks from Item 4	O	H	8	TBD	Implement Dark Skies approach with Lighting	Dan Maguire	Nate Rudy	Nate Rudy Will Haskell	04/19/22	04/19/22	(4/19/22) Council agreed it was important to list sub tasks on big project to ensure Dark Skies approach is used when planning lighting. Next Steps: Work into upcoming planning effort.

*Status: O = Open C = Closed F = Future Priority: **H = 1-3 months M = 4-9 months L = 10+ months Last Update: 02/01/22												
No	Goal/Category	*O/ F/C	** Prty	P No.	Target Date	Description	Sub By:	Owner:	Assigned to:	Dated Logged	Last Update	Comments
A	Main Str - break out tasks from Item 89	O	H	9	12/31/21	Obtain Stormwater Capacity Analysis from MDOT	Will Haskell	Nate Rudy	Will Haskell	12/07/21	12/07/21	(12/07/21) Will advised that the MDOT is completing an analysis of the stormwater capacity of the current system which directs flow to the MTA interchange and Cemetery area. Whether the current system can handle existing stormwater and/or has additional capacity is unknown and likely not well documented in regards to options. This information is critical to the plan for upgrades to Main Street and must be obtained before stormwater modeling can be completed. Next Step: Will/Alec and Nate to work with MDOT to obtain asap.
B	Main Str - break out tasks from Item 89	O	H	9	12/31/21	Identify what level of Survey information will be available from MDOT	Will Haskell	Nate Rudy	Will Haskell	12/07/21	02/01/22	(12/07/21) Will advised it is likely the MDOT did not do a detailed survey for their upcoming projects. This detail is needed to do the level of planning the Council is asking for and will need to be done first. It is possible to leverage off what was done for survey work. (2/1) MDOT information is not sufficient for Will to proceed. Nate rec'ing no response for meeting request Next Step: Letter sent to MDOT (along with weight limit/route numbering) with CC to Legislative team.
C	Main Str - break out tasks from Item 89	O	H	9	04/01/21	Signage/Bollard Posts - Village Island	Sandy Carder	Nate Rudy	Nate Rudy	02/22/18	12/07/21	MDOT will look at what they can do to make the island at the 5 lane intersection stand out so vehicles do not go the wrong way into head on traffic. Only current sign is "ENTER" provided by MTA. New stripping is planned, but no response otherwise (9/4). 9/18 Council asked Deb to follow up with MDOT on their review - she advised she has meeting with MDOT on Wed 10/10. (12/4) Sandy asked MDOT at meeting about options. MDOT said they may have some flexible boillard type posts to try - will check their inventory. Steve noted it does make plowing more difficult. MDOT also may look at new signage - but that will require a full re-engineering of electric/posts at the intersection - see rt 115 listing on task list.(4/2) Dan advised at seeing another person drive into head on traffic in the wrong lane around the village island. (4/16) Deb advised MDOT is not willing to spend on permanent bollard due to history of destruction & costs. (6/4) Deb confirmed striping cannot be done before 7/1 (budget). Sandy asked if "ENTER" could be added to striping - may not be visible. Awaiting alternatives from MDOT. (12/7) This was originally logged under the MDOT detail tab - moving to Main Street as it will be incorporated in the plans.
D	Main Str - break out tasks from Item 89	O	H	9	TBD	Implement Dark Skies approach with Lighting	Dan Maguire	Nate Rudy	Nate Rudy Will Haskell	04/19/22	04/19/22	(4/19/22) Council agreed it was important to list sub tasks on big project to ensure Dark Skies approach is used when planning lighting. Next Steps: Work into upcoming planning effort.

*Status: O = Open C = Closed F = Future Priority: **H = 1-3 months M = 4-9 months L = 10+ months												
No	Goal/Category	*O/ F/C	** Prty	P No.	Target Date	Description	Sub By:	Owner:	Assigned to:	Dated Logged	Last Update	Comments
A	Traffic - MDOT - break out tasks from item 24A	O	M	1.1	06/01/22	Signage - Route 26 vs. Route 26A	Council	Nate Rudy	Nate Rudy	02/22/18	03/29/22	Village diversion/misdirection. Looking into eliminating/renaming route 26/26A to prevent Truckers from going the wrong way through the village. MTA committed to helping push for changes with MDOT at last night's meeting & advised a suggestion to remove Route 26 starting at Washington Ave (Portland) through to merge with 26A has been suggested in the past. Route 26A would just become Route 26. Also, Jason suggested using the Town sign by the Transfer station or other electronic signs. Note: Cathy Breen had offered to check in with Garmin to obtain more information on GPS algorithms/process - follow-up? MTA will be closing bridge in summer 2019 - good time to coordinate removing "route 26" designation from Washington Ave to bridge. Keeping it from interchange - by-pass - north only. Deb is sending note 9/4. (12/4) MTA pointed out MDOT is not in agreement with full closure of the bridge due to lack of ability for rigs to turnaround if they miss detour signs. Also, not committed to changing route signs at this time - more discussion to follow. (9/17) Sandy advised she mentioned this issue to Rep Moriarty and he advised he would be willing to look into it to determine next steps on a formal request. (10/15) Rep Moriarty has established communication with DOT legislative liaison and they are willing to set up a meeting with DOT Staff that handle routes. Council discussed having pre-meeting but feel Rep Austin & Sen Breen are up to speed - Sandy will advise Rep Moriarty. (11/12) Sandy advised a meeting is set. (12/3) Sandy reviewed results of meeting & weight limit options. MDOT to provide info on costs for signs to change designation for just in Gray. Council agreed to coordinate weight limit with sidewalk project meeting & attempt to obtain approval. (1/21) Sandy sent follow-up on sign count/costs and asked for more info on weight limit process. (2/4) Sandy adv MDOT adv they were looking into (3/10) Sandy will follow up (8/4) Follow up done MDOT still needs to discuss before getting back to us. Council to set up public forums in Sept. (9/1) Public Forum set 9/29 - Sandy to follow up again. (9/29) MDOT sent resp hours before public forum. (11/17) Sandy will draft resp to MDOT letter. (12/15) Council approved response letter to be sent with alternate proposal to remove 26 & add to 26a while 26a remains. Weight limit work will continue via communication with residents/businesses. (1/5) Letter sent. (4/6) MDOT resp - sugg 'truck route' signs, not budging on sign replacement. (5/4) Nate & Sandy meet with Sen Breen staff 5/5 & submitted historical info on issues. (12/21) Council dis at meet & Nate will follow up on details for 'cost' of signs (2/1) Letter sent to MDOT req detailed invoice for costs and MTA info. (3/1) Sandy adv Bruce Van Note meeting to be held at end of March (3/29) meet held with DOT - they will provide more detail on sign costs & Nate to reach out to MTA on costs.
A	Traffic - MTA - break out tasks for item 24B	O	M	1.2	12/31/20	Diversion Study	Town Council	Nate Rudy	Nate Rudy	02/22/18	05/18/21	Town to define goals-study/parmts/data set to cap as much data/results as poss rel to exist prior traffic issues. need to deter int partners-NG,Poland,Cumber,Auburn,Windham? MTA ind poss prov 80+% of fund, but sugg Muni commit would prov more control over study/ensure buy-in. Partners could share the costs of the 15+%. 6 fig likely need, more data added to study = high costs. Deb adv MTA is work on poss optns, costs and part comm & hopes to pres at Oct TC meet. (12/4) MTA pres new data capture/purchopt that will incr data while drop costs. Scope disc ensued w Council need to send addt'l feedback to Deb-chgs may incr costs-but MTA comm to a good study rather than just a 'cheap' one. MTA will reach out to NG next to deter if they will parti. (1/8) Deb will reach out to MTA to obtain new cont (Bruce Van Note has been appt to head the MDOT). (2/5) Mr. Mills resp, but prov no name. (2/19) Mr Mills is taking a diff appro than Mr. Van Note-he is propo MTA buy subscr at March meet. (3/5) NG is not inter in parti.(4/2) Sandy prov PPH article ind MTA, MDOT, PACTS and Port Transp grp have agrd to grp subscr to software. Await addt'l feedfrom Mr. Mills. Ress appr budget. Deb sent e-mail to Mr. Mills. (9/3) Mr. Mills adv they are still work on it. (9/17) Sandy adv COG has access to data & sent mat to S Carver as they were inter to see if there was a role for COG to play. (11/12) Steph adv COG can prov info-Sandy to ob more info. (12/3) Sandy prov up - GPCOG to take leave & prov prop for full coun to cons. (1/7) Sandy pres propos scope from COG-Counc req opts for MTA buy-in, but maj agreed to mov forw. Sandy will fol-up with Steph. Coun will vote on engage letter at 1/21 meet. (1/21) Coun voted to approve engag letter. (2/4) Sandy recap conf call with COG-ok with chgs-will look into poss ph 2 study to capture 'avoid' vs. 'divers' traffic with MDOT fund? (3/10) Sandy will follow up - Steph Carver is leaving GPCOG. Sen. Ned Claxton ask for info as his constituents in NG view this as a top issue. Sandy shared. (5/19) Study due end of June. (7/21) Delay but COG will add 'avoidance' analysis at no charge - target is Sept (9/1) Sandy adv draft report is done - final repot should be rec'd in a couple weeks. (9/15) Sandy adv final report has been rec'd - will send to Council & set up discussion when time allows. (10/6) MTA/MDOT have prov feedback to GPCOG. They resp to MTA, incorporating changes for MDOT. NG has ask for copy. Deb to talk to NG Mgr. (11/17) GPCOG resp to MDOT & are work on updating. (12/15) Sandy has rec'd updated study - will pull together all the material & send to Council. Will be placed on a future workshop agenda. (1/5) Diversion info shared (3/16) Council disc resp (1) to MTA (2) meet with Leg team + transp committee members (3) integrate in convo with MDOT on Route 100 projects (4) req mor info on LOS study costs/timeframes. (5/4) Nate & Sandy meet with Sen Breen staff 5/5 & submitted historical info on issues.

*Status: O = Open C = Closed F = Future					Priority: **H = 1-3 months M = 4-9 months L = 10+ months							
No	Goal/Category	*O/ F/C	** Prty	P No.	Target Date	Description	Sub By:	Owner:	Assigned to:	Dated Logged	Last Update	Comments
B	Traffic - MTA - break out tasks for Item 24B	O	M	1.2	06/01/21	MTA Data - cash collection (vs EZPASS)	Town Council	Sandy Carder	Sandy Carder	02/22/18	05/04/21	<p>MTA will prov data for cash (vs EZPASS) from the regl booths-Gray,NG,Falm - to better deter funds being collect by high tolls. Ident collect funds will prov base to deter alter in toll location prices. Toll Data was prov, but Sandy asked if classes could be split out (12/4) Some minor toll disc occured at meet with MTA confir they can prov addt'l info. (2/19) Council disc opts for toll chgs and agreed to send letter to MTA with recomm/feedback. (4/16) Sandy prov draft to Council. Dan prov feed to Sandy. Council prov feed to finalize letter in 5/7 meet & appr letter at 5/21 meet. Deb has sent. (8/6) Deb to follow up. Council agreed needed to follow-up before pull in Repres and/or Governor's office. (9/3) Mr. Mills resp as he has in the past. (9/17) Sandy met with Rep Moriarity & he agreed next step is a letter to Rep/Breen and Governor and perhaps they can meet to see what add pressue they can apply-incl the issue of Complete street policy. (10/15) Sandy proposed alter approach of asking Leg. Reps to submit the issue to the Governor's Blue Ribbon Commis for consid as several fund pieces related to both toll inequity and diversion. Dan pointed out use of 295 (or 95 north of Augusta) by commut vs those forced to use 95 (south) is an issue as well. Council agreed and also want to focus on ask Leg. Reps to consider a bill that would put more teeth in the MTA complete street policy and give muni more say. Sandy will draft for Council rev at 11/12 meet. (11/12)Letter rev with feed prov. Sharon expressed concerns with tone of letter. Maj of Council felt it needed to be strongly worded esp given news story where Mr. Mills was dismissive of issues. Sandy remind that it is to the legis team, not the MTA directly. Sandy to update and send. (12/3) Council approved letter. (2/4) Sandy adv committee contin work - follow up after session (2/18) Sandy prov update on status of comm and council agreed we should follow up now. (3/10) Sandy shared with Sen. Ned Claxton upon request (3/16/21) See above Diversion (5/4) Nate & Sandy meet with Sen Breen 5/5</p>

*Status: O = Open C = Closed F = Future Priority: **H = 1-3 months M = 4-9 months L = 10+ months												Last Update: 07/05/22
No	Goal/Category	*O/ F/C	** Prty	P No.	Target Date	Description	Sub By:	Owner:	Assigned to:	Dated Logged	Last Update	Comments
10	Administrative	F				Develop process to review status of Paper Streets	Town Council	N/A	N/A	01/22/18	01/16/18	During the Council discussion related to approving an extension to ROW access to 'paper streets', the Council inquired if there was a long term goal to create a process to review/identify streets which should be removed from the list. Resources/timing were discussed as hinderances. Council set this activity to "Future" given the renewal timeframe of 20 years has been reset. Future items will be reviewed annually, at a minimum.
21	Administrative	F				Develop a method to analyze & potentially rank Committee Volunteer applications when more than one received for one spot.	Dan Maguire	N/A	N/A	02/09/18		During a workshop discussion on Jan. 8th, the Council agreed there could be situations where a formal review/ranking system may be appropriate, but it is unlikely one needs to be used in most situations. The Council reviewed a variety of options, ideas, etc., but decided to table this issue for a later date. Will be considered a 'future' item.
31	Ordinance	F				Review the issues and options surrounding Dock Lighting / Light pollution.	Deb Cabana	N/A	N/A	04/17/18	06/05/18	Town Staff has received a complaint/inquiry surrounding light pollution issues related to new LED dock lighting equipment. Given Councilor Foshay was absent at the Apr. 17th meeting, Council agreed to log (as it will be covered regardless - in closed, future or open), but to hold off discussion & prioritization until May 1st meeting review. Council discussed at June 5th meeting agreeing this would be considered a future item based on lack of available information. Possible OAC research item.
17	Economic Development / Budget	F				Research and compile data and options for a possible Community Center in Gray.	Town Council	N/A	N/A	01/22/18	05/07/19	During a Sept. TC Workshop discussing goals, the Recreation Dept. provided a proposal to realign funds collected by the Rec. programs under the Rec. Dept for use in maintaining/expanding programs. One major challenge identified was the lack of space to expand programs which create revenue streams for the Town. A new space (Community Center) was identified as a possible solution which could be paid for with current revenue streams. TC expressed support to obtain more information. Next Step: Rec. Dept. Staff will begin work to outline plan to obtain additional information. Council agreed this will be considered a "closed" Council item until the Rec. Dept. brings forth additional information. With availability of some land around the by-pass, this was discussed in 9/4 TC meeting. Deb stated \$62,000 is in the current fund. (11/13) Council agreed to move to Future list as the item continues to come up in discussions. (5/7) Concerns regarding current status vs. best practices were discussed during the 4/16 meeting - confirming programs exceed capacity at the Town facilities. See Closed item #57. Manager advised it was Administrative and under her purview, council agreed to add to this item & close #57 with Manager bringing forward any necessary policy issues.
23	Ordinance	F			TBD	Review current ordinance governing noise for updates and research possible odor ordinance .	Town Council	Deb Cabana	Doug Webster	02/09/18	10/01/19	During the special amusement license renewal of the American Legion Hall, much discussion was centered around the current decibel restrictions for noise in the existing ordinance was set at a reasonable level, existing activities that may be above that level, how the level would measured (by whom), and how complaints/enforcement would be handled. Doug Webster made presentation (3/6) of review/recommendations from Town Staff - raise limit to 60. TC discussed pros & cons of setting an actual decibel limit & enforcement. TC agreed to raise to 60, but also to add specific types of businesses/activities that would trigger limit. The Mfg Overlay/BD1/BD2 already have some type of noise restriction. Need to determine how complaints would be handled. (2/19) Council agreed to add "odor" to this item. (10/1) OAC feels due to lack of technology, other priorities and inability to enforce, this items should be moved to the future list. Council agreed.

*Status: O = Open C = Closed F = Future Priority: **H = 1-3 months M = 4-9 months L = 10+ months												Last Update: 07/05/22
No	Goal/Category	*O/ F/C	** Prty	P No.	Target Date	Description	Sub By:	Owner:	Assigned to:	Dated Logged	Last Update	Comments
80	Ordinance	F			TBD	To create rules for Chickens in the various zones in Gray	Anne Gass	TBD		07/21/20		(7/21) A couple issues have arisen regarding Chickens and understanding what is and is not allowed. No real defined information in Town ordinances. Should be addressed at some point.
83	Infrastructure	F			TBD	Identify Otelco Poles to be removed on short Shaker Road	Alec Dodd	TBD		12/01/20		(12/1) As part of the pole analysis done for the short Shaker Rd 2021 Spring stormwater/sidewalk project, Alec talked to Otelco. Several poles only support old copper wire services. Once all users are transitioned to Fiber services, those poles can be removed altogether.
50	Economic Development	F	L	6	11/01/21	Work with the Narrow Gauge Railroad to review current situation and develop new plan.	Council	Nate Rudy	Nate Rudy	03/05/19	09/21/21	NGRR Board members made a presentation at the 3/5 TC meeting to update Council on recent events (loss of lease - deadline end of Oct and relocation of museum pieces on temporary basis to another location). Council/NGRR agreed a more detailed meeting was in order to determine what options remain for relocation to Gray, what resources would be needed - monetary/human, and the associated timelines. (4/16) Deb advised Doug had a meeting with NGRR Board and they are open to discussion, but cannot do at this time due to pending move. (8/6) Portland Press Herald reported the NGRR has withdrawn their plans to move to Gray and NGRR has removed trains & sign from Plaza. Council discussed how frustrating it is to find out via paper especially given this is the 2nd time and during the last visit by NGRR, the organization insisted they were still partnering with Gray. (9/3) Deb adv no response from e-mails - phone tag with Mr. Heinz - NGRR has engaged a broker to sell property. (9/17) Council discussed approaching NGRR to open discussion about donating the easement rights to the tracks to Gray - as a way to address those who contributed to NGRR relocation - both with time & money. (10/15) NGRR has responded. (12/3) Sharon wished to send an editorial letter to the paper regarding this item, but was willing to wait to see if the meeting is set after the Polar Express is done. Council felt current course was correct one. (1/7) Now that the Polar Express season has ended, Deb will follow up on meeting. (1/21) NGRR said they would get back to her (2/18) NGRR advised they are seeking professional assistance to deal with unraveling Gray issues. (9/15) NGRR sold a portion of the ROW to a private developer without notifying the Town or updating Deb as they said they would. Anne also adv NGRR will be just sitting on their property until values increase to allow them to break even with mortgage. Council is frustrated but since it is a private deal & does not involve Town, there is no legal leverage. (10/6) Council rev & app letter to be sent to NGRR. (9/21) Council sees no action happening on this so moving to future. NGRR has sold off pieces of their property without any contact with the Town as far as donating easements on the rail line.
98	Ordinance	F			TBD	Create a Mooring Ordinance for all Gray Lakes	Sharon Young			10/05/21	10/05/21	(10/05/21) Sharon Young submitted this request prior to her Council term expiration. The Council reviewed at the 10/5 meeting and agreed it was an issue that needed to be looked into; however, given there is a bill before the State Legislature (2nd session set to begin in 01/2022), Council wants to wait to see what the State decides to do or not do. In addition, more information is needed. The Lake Coalition presented information on a Shoreland Protection Ordinance they requested the Town create and there is likely going to be more discussion on that item. Mooring information could be collected at the same time.
36	Administrative	F			??	Review the current process for "Planned Unit Development" commercial subdivision to determine if routing the review & approval of commercial uses on lots in a PUD subdivision to the Staff Review Committee in lieu of the Planning Board.	Kathy Tombarelli	Nate Rudy	Nate Rudy	09/04/18	07/06/21	This item was brought up & discussed in the TC 8/7/18 meeting. Town Councilors agreed to consider the proposal, but could not determine whether support would be granted until some draft language was provided. Councilors expressed various concerns about the process which they would like addressed in that language. The Planning Board has also expressed some concerns with the change given PUDs are relatively new. (1/22) Dan advised Planning bd is okay with change as Planning Bd Chair sits on Staff Review Committee. (7/6) Nate needs to check the status of this one. (3/15) So far none of these reviews have come up; therefore moving to future for later consideration if issues arise.

*Status: O = Open C = Closed F= Future Priority: **H = 1-3 months M = 4-9 months L = 10+ months Last Update: 07/05/22												
No	Goal/Category	*O/ F/C	** Prty	P No.	Target Date	Description	Sub By:	Owner:	Assigned to:	Dated Logged	Last Update	Comments
116	Ordinance	E			??	Review existing Medical and Recreation Marijuana Ordinance for possible changes	Residents	TBD	TBD	07/05/22	07/05/22	(7/5/22) In a past TC session, a resident who currently grows medicinal MJ in the Plaza requested consideration to expand his business to consider recreational. The Council at the time felt the ordinance had just been modified and advised they would not consider for at least 6-12 months. Recently, a medical caregiver spoke at a TC meeting requesting consideration to allow medical store fronts in Gray. The previous resident also reached out to Anne Gass to re-submit his request. Council discussed at the 7/5 workshop and there was consensus that it is time to review the ordinance for possible changes in the area of cultivation and store fronts with restrictions. However, given the work planned in the next 6 months, were unsure if resources would be available this session. Council agreed to review this along with the entire Future list at the upcoming Council Retreat in Sept.