



**CITY OF LOCKPORT  
CITY COUNCIL MEETING  
AGENDA**

**WEDNESDAY, MAY 17, 2023  
CITY HALL, 3RD FLOOR, BOARD ROOM**

**7:00 PM OR AT THE CONCLUSION OF THE  
COMMITTEE OF THE WHOLE MEETING**

---

**A. PLEDGE OF ALLEGIANCE**

**B. ROLL CALL**

**C. INTRODUCTION**

**D. AGENDA PARTICIPATION**

(Any person who wishes to speak on a topic that is on the Agenda of the Meeting shall fill out a Speaker Card before the start of the Meeting, either at the City Clerk's Office, or may give to the City Clerk before the start of the Meeting itself, stating name, and topic on the Agenda to be discussed. Speaker Cards are required for each of the items the Speaker wishes to address. The purpose of the Cards is to obtain the spelling of name of the Speaker, contact information, and provide for efficient meeting administration. All Speakers shall comply with these rules, which shall be posted at the Speaker Sign-In desk and rulings of the City Clerk. Speakers shall be called by name to approach the podium by the City Clerk. A time limit of five (5) minutes shall be imposed on each Speaker.)

Illinois Municipalities may adopt a group of assorted Ordinances, Resolutions, Motions, and orders by a single Roll Call Vote called an Omnibus Vote or approval by Consent Agenda. The Omnibus Vote/Consent Agenda Vote shall be taken following the unanimous consent by the City Council as to the items to be included in the vote. There will be no separate discussion on these items unless a Council Member or Citizen so requests. In that event, the item will be removed from the Omnibus Vote/Consent Agenda and considered in its normal sequence on the Agenda

**E. CONSENT AGENDA**

CL-1. [Committee of the Whole Meeting Minutes from May 3, 2023](#)

Suggested Action: Approve the Committee of the Whole Meeting Minutes from May 3, 2023 as presented.

CL-2. [Regular City Council Meeting Minutes from May 3, 2023](#)

Suggested Action: Approve the Regular City Council Meeting Minutes from May 3, 2023 as

presented.

- FN-1. [Payroll Period Ending April 30, 2023](#)  
Suggested Action: Approve the payroll period as presented.
- AT-1. [Amendment to Section 130.01 of Lockport Code of Ordinances Correcting the Definition of Assault](#)  
Suggested Action: Ordinance No. 23-018 amending Section 130.01 of Chapter 130 of the Lockport Code of Ordinances correcting the definition of Assault.
- CD-1. [Final Development Plan Review for a Restaurant with a Drive-Thru Facility, Lot 1A \(Panda Express\) in Rose Lockport Center /PZC Case #2023-003](#)  
Suggested Action: Approve Resolution No. 23-043 the Final Development Plans for a 2,667 sf Commercial Building for a Restaurant with drive thru facility in Rose Lockport Center, Lot 1A (Panda Express Restaurant).
- PW-1. [Release of Bond and Initial Acceptance of Site Improvements for Homer Tree Service, Inc.](#)  
Suggested Action: Approve Resolution No. 23-040 for the Release of Bond and Initial Acceptance of Site Improvements for Homer Tree Service, Inc.

**F. APPROVAL OF MEETING MINUTES (IF NOT APPROVED AS A CONSENT AGENDA ITEM)**

**G. APPROVAL OF PAYROLL (IF NOT APPROVED AS A CONSENT AGENDA ITEM)**

**H. REGULAR BUSINESS ACTION ITEMS**

- FN-1. [Bills Through May 9, 2023](#)  
Suggested Action: Approve the various bills as presented.
- AT-1. [Amendment to Chapter 111 of the City's Liquor Code Amending Class M \(Haunted House/Paint Ball\), Class N \(Truck Stops\), Increase the Caps on Class M and N, and Class N Prohibit the Sale of Mini-Sized Packaged Liquor](#)  
Suggested Action: Approve Ordinance No. 23-016 amending Chapter 111 of the Lockport Code of Ordinances related to Class M, Class N, increase the cap on Class M & Class N Liquor Licenses, and Class N prohibition of the sale of mini-sized alcoholic liquor.
- CD-1. [Special Use Permit to Allow Expansion of the Existing Lockport Cemetery for the Property Generally Located East of Madison Street and North of 7th Street](#)  
Suggested Action: Approve Ordinance No. 23-017 the Special Use Permit to allow the expansion of Lockport Cemetery.

**I. PUBLIC HEARING**

**J. PERMANENT COMMITTEES**

**K. NEW BUSINESS**

**L. OPEN FLOOR FOR COMMENTS**

(Comments will be heard on items that do not appear on the Agenda. The Public Comment portion of the Agenda shall be subject to a twenty (20) minute limitation. A time limit of five (5) minutes shall be imposed on each Speaker.

The purpose of having Public Comments as an Agenda item is to allow any person to make his/her views known to the City Council upon any subject of general or public interest.

Each person wishing to speak during the Public Comment portion of the Agenda must fill out a Public Comment Speaker Card stating name, and the topic about which he/she wishes to speak as well as a sign-in sheet, and give to the City Clerk at the Meeting itself.

The purpose of the Cards is to obtain the spelling of the name of the Speaker, and provide for efficient meeting administration.

The order of speaking shall be based upon the order of sign-in with first person signing-in speaking first and so forth. If the twenty (20) minutes has elapsed before all Speakers who have signed up are allowed to speak, the City Council may elect to continue the time period.

However, if the City Council elects not to extend the time period those Speakers who signed up but did not speak may if they so choose to be placed on the next Agenda under the Public Comments Section and shall be placed at the top of the Sign-In Sheet in the same order they were in from the previous Sign-In Sheet.

All Speakers shall comply with these rules which shall be posted at the Speaker Sign-In desk and rulings of the City Clerk.)

**M. EXECUTIVE SESSION: OPEN MEETINGS EXEMPTIONS**

2(c)(1) Appointments, Employment, Compensation, Discipline, Performance or Dismissal of specific Employees.

2(c)(2): Collective negotiating matters between the public body and its employees or their representatives, or deliberations concerning salary schedules for one or more classes of employees.

2(c)(3) Selection of a person to fill a Public Office, including a vacancy in a Public Office.

2(c)(5) Purchase or Lease of real property, including meetings held for the purpose of discussing whether a particular parcel should be acquired.

2(c)(6) The setting of a price for Sale or Lease of property owned by the public body.

2(c)(11) Litigation, when an action against, affecting or on behalf of the particular public body has been filed and is pending before a court or administrative tribunal, or when the public body finds that an action is probable or imminent, in which case the basis for the finding shall be recorded and entered into the minutes of the closed meeting.

2(c)(21) Discussion of minutes of meetings lawfully closed under this Act, whether for purposes of approval by the body of the minutes or semi-annual review of the minutes as mandated by Section 2.06

**N. ADJOURNMENT**



## City Council

### Agenda Memorandum

Item # CL-1

---

**To:** Mayor & City Council

**From:** Donna Tadey, Administrative Deputy City Clerk

**Subject:** Committee of the Whole Meeting Minutes from May 3, 2023

**Date:** Wednesday, May 17, 2023

#### **BACKGROUND/HISTORY**

Provided are the Committee of the Whole Meeting Minutes as presented.

#### **PROS/CONS/ALTERNATIVES**

N/A

#### **RECOMMENDATION**

Approve the Committee of the Whole Meeting Minutes as presented.

#### **ATTACHMENTS**

[Committee of the Whole Meeting Minutes from May 3, 2023](#)

#### **SPECIFIC CITY COUNCIL ACTION REQUIRED**

Approve the Committee of the Whole Meeting Minutes from May 3, 2023 as presented.

# LOCKPORT

**Mayor**

Steven Streit

**City Clerk**

Kathleen Gentile

**Administrator**

Ben Benson

**Alderman**

Matt Kairis - 1st Ward  
Jonathan Pugh - 1st Ward  
Patrick McDonald - 2nd Ward  
JR Gillogly - 2nd Ward  
Darren Deskin - 3<sup>rd</sup> Ward  
Christina Bergbower - 3rd Ward  
Renee Saban - 4th Ward  
Joanne Bartelsen - 4th Ward

***City of Historic Pride***

222 E. Ninth Street Lockport, IL 60441-3497

***Proceedings of the Committee of the Whole  
of the City of Lockport, Illinois  
May 3, 2023***

VIDEO IS HEREIN INCORPORATED  
INTO THE OFFICIAL MINUTES

REGULAR MEETING of the Committee of the Whole of the City of Lockport, Illinois was held on Wednesday, May 3, 2023 in the Board Room, 3rd Floor, of the Central Square Building, 222 E. Ninth Street, Lockport, Illinois. Mayor Steve Streit called the Meeting to order at 7:11 pm.

**ROLL CALL**

**PRESENT:** Mayor, Steve Streit  
Alderman, Renee Saban  
Alderman, Joanne Bartelsen  
Alderman, Darren Deskin  
Alderman, Christine Bergbower  
Alderman, JR Gillogly  
Alderman, Patrick McDonald  
Alderman, Matt Kairis  
Alderman, Jonathan Pugh

**ABSENT:** NONE

**ALSO PRESENT:** City Clerk, Kathy Gentile  
City Administrator, Ben Benson  
Finance Director, Lisa Heglund  
City Attorney, Sonni Choi Williams  
Director of Public Works, Brent Cann  
Director of Community & Economic Development, Lance Thies  
Chief of Police, Richard Harang

**PRESS:** Cathy Wilker, LCTV

***Proceedings of the Committee of the Whole  
of the City of Lockport, Illinois  
May 3, 2023***

VIDEO IS HEREIN INCORPORATED  
INTO THE OFFICIAL MINUTES

---

**SWEARING IN OF NEWLY ELECTED OFFICIALS**

- Darren Deskin
- JR Gillogly
- Joanne Bartelsen
- Patrick McDonald
- Jonathan Pugh

**LIAISON'S REPORT**

1. Saban – Summer Art Series
  - a. May 26 – Singing in the Rain – at the Roxy
  - b. June 2 – Fridays in the Park – Truman's Ridge band
  - c. June 5 – Monday night Cruisin in Lockport starts
2. Bartelsen
  - a. Spring/Summer Beautification Recognition
  - b. To enhance the competition this year: 1<sup>st</sup> place \$100, 2<sup>nd</sup> place \$75, 3<sup>rd</sup> place \$50
  - c. Separate recognition for Fall and Winter seasons
3. McDonald
  - a. City of Lockport received Budget Award – 8<sup>th</sup> year in a row from the Government Finance Officers Association
4. Gillogly
  - a. City of Lockport received Illinois Fluoridation Act Award from the Illinois Department of Public Health
  - b. Branch pick-up starts this week – branches must be less than 5 inches in diameter
5. Benson
  - a. Old Canal Days – June 8-11

**ITEMS RECOMMENDED TO BE PLACED ON THE AGENDA FOR CONSENT OR ACTION AT THE NEXT  
REGULARLY SCHEDULED CITY COUNCIL MEETING**

**CA-1. Stakeholder Meeting for the City of Lockport to Utilize DCEO Grant Funds in the Amount  
of \$360,245.00 for Maryknoll Dr. Watermain Installation Project**

City Administrator, Ben Benson, extended thanks to Brent, Lisa and Lance, who prepared the presentation for the grant. Director of Community & Economic Development, Lance Thies, shared details about how the grant funds will be used for the watermain project.

***Proceedings of the Committee of the Whole  
of the City of Lockport, Illinois  
May 3, 2023***

VIDEO IS HEREIN INCORPORATED  
INTO THE OFFICIAL MINUTES

---

Deskin raised question about the route of the watermain; an easement will be obtained.

**DIRECTION: FOR INFORMATION ONLY**

**CD-1. Final Development Plan Review for a Restaurant with a Drive-Thru Facility, Lot 1A (Panda Express) in Rose Lockport Center /PZC Case #2023-003**

Director of Community & Economic Development, Lance Thies, presented the Staff Report for the proposed development for Panda Express.

**DIRECTION: Add to the Consent Agenda for the May 17 City Council Meeting**

Alderman Darren Deskin recused himself prior to the Council review of agenda item CD-2.

**CD-2. Special Use Permit to Allow Expansion of the Existing Lockport Cemetery for the Property Generally Located East of Madison Street and North of 7th Street**

Director of Community & Economic Development, Lance Thies, presented the Staff Report. The Applicant is seeking to acquire an adjacent plot which requires review and rezoning of the entire property. The cemetery is privately held.

**DIRECTION: Add as an Action Item to the Agenda for the May 17 City Council Meeting**

Alderman Darren Deskin returned to the Council meeting upon completion of discussion on agenda item CD-2.

**PW-1. Release of Bond and Initial Acceptance of Site Improvements for Homer Tree Service, Inc.**

Director of Public Works, Brent Cann, presented the Staff Report to release the surety bond in its entirety.

**DIRECTION: Add to the Consent Agenda for the May 17 City Council Meeting**

***Proceedings of the Committee of the Whole  
of the City of Lockport, Illinois  
May 3, 2023***

VIDEO IS HEREIN INCORPORATED  
INTO THE OFFICIAL MINUTES

---

**AT-1. Amendment to Section 130.01 of Lockport Code of Ordinances Correcting the Definition of Assault**

City Attorney, Sonni Choi Williams, presented the Staff Report. The amendment is intended to correct an error on the definition of Assault; it is currently defined the same as Battery. The issue was identified by City Police.

**DIRECTION: Add to the Consent Agenda for the May 17 City Council Meeting**

**AT-2. Amendment to Chapter 111 of the City's Liquor Code Amending Class M (Haunted House/Paint Ball), Class N (Truck Stops), Increase the Caps on Class M and N, and Prohibit the Sale of Mini-Sized Packaged Liquor**

City Attorney, Sonni Choi Williams, presented the Staff Report for the amendment to City's Liquor Code for retail liquor sales. The sales is limited to off-site consumption, not sales for on-site consumption.

Discussion among the Council ensued to clarify the Class N truck stop, large truck stop requirements to sell packaged liquor. The combined total of liquor licenses to be approved by the Liquor Commissioner will be limited to a max of 3 for Class N, and a max of 2 for Class M. Regular gas stations within the City of Lockport do not sell packaged liquor.

**DIRECTION: Add as an Action Item to the Agenda for the May 17 City Council Meeting**

**ADJOURNMENT**

**MOTION TO ADJOURN THE COMMITTEE OF THE WHOLE MEETING, AT 7:51 pm. MOTION BY BARTELSEN, SECONDED BY GILLOGLY. MOTION PASSED BY VOICE VOTE.**

---

**KATHLEEN GENTILE**  
City Clerk



## City Council

### Agenda Memorandum

Item # CL-2

---

**To:** Mayor & City Council

**From:** Donna Tadey, Administrative Deputy City Clerk

**Subject:** Regular City Council Meeting Minutes from May 3, 2023

**Date:** Wednesday, May 17, 2023

#### **BACKGROUND/HISTORY**

Provided are the Regular City Council Meeting Minutes as presented.

#### **PROS/CONS/ALTERNATIVES**

N/A

#### **RECOMMENDATION**

Approve the Regular City Council Meeting Minutes from May 3, 2023 as presented.

#### **ATTACHMENTS**

[Regular City Council Meeting Minutes from May 3, 2023](#)

#### **SPECIFIC CITY COUNCIL ACTION REQUIRED**

Approve the Regular City Council Meeting Minutes from May 3, 2023 as presented.

# LOCKPORT

**Mayor**

Steven Streit

**City Clerk**

Kathleen Gentile

**Administrator**

Ben Benson

**Alderman**

Matt Kairis - 1st Ward  
Karen Kostecki - 1st Ward  
Patrick McDonald - 2nd Ward  
JR Gillogly - 2nd Ward  
Christina Bergbower – 3rd Ward  
Renee Saban - 4th Ward  
Joanne Bartelsen - 4th Ward  
Mark Lobes – At-large

**City of Historic Pride**

222 E. Ninth Street Lockport, IL 60441-3497

## ***Proceedings of the City Council of the City of Lockport, Illinois May 3, 2023***

VIDEO IS HEREIN INCORPORATED  
INTO THE OFFICIAL MINUTES

REGULAR MEETING of the City Council of the City of Lockport, Illinois was held on Wednesday, May 3, 2023 in the Board Room, 3rd Floor, of the Central Square Building, 222 E. Ninth Street, Lockport, Illinois. Mayor Steve Streit called the Meeting to order at 7:00 p.m.

**INVOCATION** – Pastor Ernest Jones, Christ Vision Community Church

**ROLL CALL**

**PRESENT:** Mayor, Steve Streit  
Alderman, Renee Saban  
Alderman, Joanne Bartelsen  
Alderman, Christine Bergbower  
Alderman, Mark Lobes  
Alderman, JR Gillogly  
Alderman, Patrick McDonald  
Alderman, Matt Kairis  
Alderman, Karen Kostecki

**ABSENT:** NONE

**ALSO PRESENT:** City Clerk, Kathy Gentile  
City Administrator, Ben Benson  
Finance Director, Lisa Heglund  
City Attorney, Sonni Choi Williams  
Director of Public Works, Brent Cann  
Director of Community & Economic Development, Lance Thies  
Chief of Police, Richard Harang

**PRESS:** Cathy Wilker, LCTV

**Proceedings of the City Council of the City of Lockport, Illinois  
May 3, 2023**

VIDEO IS HEREIN INCORPORATED  
INTO THE OFFICIAL MINUTES

---

**APPROVAL OF CONSENT AGENDA ITEMS**

**MOTION BY LOBES, SECONDED BY KOSTECKI, TO REVIEW CONSENT AGENDA. ROLL CALL VOTE ON THE MOTION:**

**AYES – SABAN, BARTELTSEN, LOBES, BERGBOWER, GILLOGLY, MCDONALD, KAIRIS, KOSTECKI**

**NAYS - NONE**

**ABSENT – NONE**

**ABSTAIN – NONE**

**8 AYES, 0 NAY, 0 ABSENT, 0 ABSTAIN – MOTION CARRIED**

1. CL-1. Committee of the Whole Meeting Minutes from April 19, 2023 Suggested Action: Approve the Committee of the Whole Meeting Minutes from April 19, 2023 as presented.
2. CL-2. Regular City Council Meeting Minutes from April 19, 2023 Suggested Action: Approve the Regular City Council Meeting Minutes from April 19, 2023 as presented.
3. FN-1. Payroll Period Ending April 16, 2023 Suggested Action: Approve the payroll period as presented.
4. PW-1. Approving the Appropriation and Eligibility of MFT Funds for the Maintenance of Streets and Highways by Municipality Under the Illinois Highway Code in the Amount of \$350,372 Suggested Action: Approve Resolution No. 23-039 IDOT Form - BLR 14220.

**MOTION BY BARTELTSEN, SECONDED BY SABAN, TO APPROVE CONSENT AGENDA. ROLL CALL VOTE ON THE MOTION:**

**AYES – SABAN, BARTELTSEN, LOBES, BERGBOWER, GILLOGLY, MCDONALD, KAIRIS, KOSTECKI**

**NAYS - NONE**

**ABSENT – NONE**

**ABSTAIN – NONE**

**8 AYES, 0 NAY, 0 ABSENT, 0 ABSTAIN – MOTION CARRIED**

**REGULAR BUSINESS**

**FN-1. Bills Through April 25, 2023**

**MOTION TO APPROVE THE VARIOUS BILLS AS PRESENTED. MOTION BY SABAN, SECONDED BY MCDONALD. ROLL CALL VOTE ON THE MOTION:**

**AYES – SABAN, BARTELTSEN, LOBES, BERGBOWER, MCDONALD, KAIRIS, KOSTECKI**

**NAYS - NONE**

**ABSENT – NONE**

**ABSTAIN – GILLOGLY**

**7 AYES, 0 NAY, 0 ABSENT, 1 ABSTAIN – MOTION CARRIED**

***Proceedings of the City Council of the City of Lockport, Illinois  
May 3, 2023***

VIDEO IS HEREIN INCORPORATED  
INTO THE OFFICIAL MINUTES

---

**FN-2. Cell Tower 99-Year Lease Agreements with Crown Castle for \$202,475 Net of Fees**

**MOTION TO APPROVE ORDINANCE NO. 23-019 A 99 YEAR LEASE AGREEMENT WITH GLOBAL SIGNAL ACQUISITIONS IV LLC (CROWN CASTLE) FOR TOWER EASEMENT FOR FACILITY NO. 843142. MOTION BY LOBES, SECONDED BY SABAN. ROLL CALL VOTE ON THE MOTION:  
AYES – SABAN, BARTELSEN, LOBES, BERGBOWER, GILLOGLY, MCDONALD, KAIRIS, KOSTECKI  
NAYS - NONE  
ABSENT – NONE  
ABSTAIN – NONE  
8 AYES, 0 NAY, 0 ABSENT, 0 ABSTAIN – MOTION CARRIED**

**CD-1. Façade & Site Improvement Grant Request for Taft School Located at 1605 S. Washington Street in the Amount of \$2,195.00 for the Replacement of Wall Signage**

**MOTION TO APPROVE RESOLUTION NO. 23-042 A SITE IMPROVEMENT GRANT FOR THE PROPERTY LOCATED AT 1605 S. WASHINGTON STREET IN THE AMOUNT OF \$2,195.00. MOTION BY BERGBOWER, SECONDED BY MCDONALD. ROLL CALL VOTE ON THE MOTION:  
AYES – SABAN, BARTELSEN, LOBES, BERGBOWER, GILLOGLY, MCDONALD, KAIRIS, KOSTECKI  
NAYS - NONE  
ABSENT – NONE  
ABSTAIN – NONE  
8 AYES, 0 NAY, 0 ABSENT, 0 ABSTAIN – MOTION CARRIED**

**PW-1. Award 2023 Resurfacing Project to Gallagher Asphalt Corporation in the Bid Amount of \$2,882,902.93 and Approve Additional Budgeted Funds for a Total Not-To-Exceed Amount of \$3,000,000.00**

Director of Public Works, Brent Cann, informed the Council that the project will cover all of Karen Springs subdivision and part of 2<sup>nd</sup> Street.

**MOTION TO APPROVE RESOLUTION NO. 23-041 TO AWARD 2023 RESURFACING PROJECT TO GALLAGHER ASPHALT CORPORATION IN THE BID AMOUNT OF \$2,882,902.93 AND APPROVE ADDITIONAL BUDGETED FUNDS FOR A TOTAL NOT-TO-EXCEED AMOUNT OF \$3,000,000.00. MOTION BY KOSTECKI, SECONDED BY SABAN. ROLL CALL VOTE ON THE MOTION:  
AYES – SABAN, BARTELSEN, LOBES, BERGBOWER, MCDONALD, KAIRIS, KOSTECKI  
NAYS - NONE  
ABSENT – NONE  
ABSTAIN – GILLOGLY  
7 AYES, 0 NAY, 0 ABSENT, 1 ABSTAIN – MOTION CARRIED**

***Proceedings of the City Council of the City of Lockport, Illinois  
May 3, 2023***

VIDEO IS HEREIN INCORPORATED  
INTO THE OFFICIAL MINUTES

---

**PW-2. Accept Quote for Secondary Clarifier Repairs in the Amount of \$100,000.00 from DPS Equipment Services, Inc.**

**MOTION TO APPROVE RESOLUTION NO. 23-044 TO ACCEPT QUOTE FOR THE SECONDARY CLARIFIER REPAIRS IN THE AMOUNT OF \$100,000.00 FROM DPS EQUIPMENT SERVICES, INC. MOTION BY MCDONALD, SECONDED BY GILLOGLY. ROLL CALL VOTE ON THE MOTION:  
AYES – SABAN, BARTELSEN, LOBES, BERGBOWER, GILLOGLY, MCDONALD, KAIRIS, KOSTECKI  
NAYS - NONE  
ABSENT – NONE  
ABSTAIN – NONE  
8 AYES, 0 NAY, 0 ABSENT, 0 ABSTAIN – MOTION CARRIED**

**MAYOR'S REPORT**

1. Thanks to Alderman Mark Lobes and Alderwoman Karen Kosteci for their service on City Council
2. Special plaque and dedication of Larry Schreiber's service on Council

**ADJOURNMENT**

**MOTION BY KOSTECKI, SECONDED BY LOBES, TO ADJOURN THE CITY COUNCIL MEETING, 7:09 PM. MOTION APPROVED BY VOICE VOTE.**

---

**KATHLEEN GENTILE  
City Clerk**

# PAYROLL SUMMARY

For Pay Period April 17 - April 30, 2023  
Paid on May 5, 2023  
Fiscal Year 2023

Department	CURRENT PAY PERIOD <sup>1</sup>				YEAR TO DATE <sup>2</sup>					
	Base Salary		Overtime		Base Salary			Overtime		
	Actual	Budget	Actual	Budget	Actual	Budget	%	Actual	Budget	%
Administration & City Council	\$ 27,941.83	\$ 27,307.69	\$ -	\$ 38.46	\$ 216,737.87	\$ 245,769.23	88.2%	\$ 168.95	\$ 346.15	48.8%
Police	173,094.56	185,961.54	6,756.06	7,692.31	1,473,232.04	1,673,653.85	88.0%	51,102.11	69,230.77	73.8%
Planning	10,858.48	11,730.77	-	38.46	95,446.83	105,576.92	90.4%	-	346.15	n/a
Building	14,112.82	14,423.08	-	192.31	117,937.44	129,807.69	90.9%	470.75	1,730.77	n/a
Engineering **	8,918.39	18,038.46	1,534.63	192.31	76,844.91	162,346.15	47.3%	5,661.87	1,730.77	327.1%
Maintenance	6,294.92	5,538.46	-	38.46	49,200.00	49,846.15	98.7%	253.29	346.15	73.2%
Street	35,136.93	39,615.38	-	4,615.38	300,114.10	356,538.46	84.2%	10,376.70	41,538.46	25.0%
ESDA	461.54	480.77	-	-	3,923.08	4,326.92	90.7%	-	-	n/a
Special Events***	-	-	151.44	1,346.15	-	-	n/a	365.98	12,115.38	3.0%
Water - Administration	5,816.34	6,230.77	-	38.46	49,366.26	56,076.92	88.0%	-	346.15	0.0%
Water	40,056.92	41,730.77	5,375.89	4,038.46	337,413.24	375,576.92	89.8%	33,419.21	36,346.15	91.9%
Sewer	39,213.82	41,230.77	2,848.62	2,884.62	330,246.99	371,076.92	89.0%	14,572.64	25,961.54	56.1%
<b>TOTALS</b>	<b>\$ 361,906.55</b>	<b>\$ 392,288.46</b>	<b>\$ 16,666.64</b>	<b>21,115.38</b>	<b>\$ 3,050,462.76</b>	<b>\$ 3,530,596.15</b>	<b>86.4%</b>	<b>\$ 116,391.50</b>	<b>\$ 190,038.46</b>	<b>61.2%</b>

**\*\* NOTE:** Engineering salaries related to Capital Projects construction site observations will be allocated to the costs of the related projects at the end of the year.

**\*\*\* NOTE:** Special Events line has been added and includes Canal Days

<sup>1</sup> Budgeted figures for the current pay period are calculated by taking the full budgeted line item and dividing by 26.

<sup>2</sup> Year to Date numbers are from 1/1/23 through 4/30/23



## City Council

### Agenda Memorandum

Item # AT-1

**To:** Mayor & City Council

**From:** Sonni Williams, City Attorney

**Subject:** Amendment to Section 130.01 of Lockport Code of Ordinances Correcting the Definition of Assault

**Date:** Wednesday, May 17, 2023

#### **BACKGROUND/HISTORY**

Recently, one of Lockport's Police Investigators discovered that the definition of the offense of assault incorrectly had the same definition of the offense of battery in Chapter 130 of the City of Lockport Code of Ordinances. See attached copy of Section 130.01 Assault and Section 130.02 Battery.

Ordinance No. 23-018 amends Section 130.01 of the City Code with the correct definition of assault which is the apprehension of a battery defined as bodily harm to an individual, or makes physical contact of an insulting or provoking nature with an individual.

#### **PROS/CONS/ALTERNATIVES**

This is a house-keeping change to Section 130.01 of the City Code to correct the definition of assault.

#### **RECOMMENDATION**

Approve the amendment to Section 130.01 of Chapter 130 correcting the definition of assault.

#### **ATTACHMENTS**

[Ordinance No. 23-018 Amendment of Chap 130 RE Assault](#)

[Current City Code with Definitions of Assault and Battery](#)

#### **SPECIFIC CITY COUNCIL ACTION REQUIRED**

Ordinance No. 23-018 amending Section 130.01 of Chapter 130 of the Lockport Code of Ordinances correcting the definition of Assault.

**ORDINANCE NO. 23-018**

**AN ORDINANCE AMENDING SECTION 130.01 OF CHAPTER 130 OF THE  
LOCKPORT CODE OF ORDINANCES RELATING TO ASSAULT**

**Published in pamphlet form by authority of the Mayor  
and the City Council of the City of Lockport, Will County, Illinois,  
this \_\_\_ day of \_\_\_\_\_, 2023.**

**ORDINANCE NO. 23-018**

**AN ORDINANCE AMENDING SECTION 130.01 OF CHAPTER 130 OF THE  
LOCKPORT CODE OF ORDINANCES RELATING TO ASSAULT**

**WHEREAS**, the City of Lockport is a home rule unit pursuant to Section 6 of Article VII of the Illinois Constitution of 1970; and

**NOW, THEREFORE**, be it ordained by the Mayor and the City Council of Lockport, Will County, Illinois, as follows:

**SECTION 1:** Chapter 130 of the City of Lockport Code of Ordinances, Section 130.01, is hereby amended by deleting the stricken and adding the underlined as follows:

**§ 130.01 ASSAULT.**

A person commits the offense of ~~battery~~assault when he or she intentionally and knowingly, without legal justification, engages in a conduct which places another in reasonable apprehension of receiving a battery~~by any means causes bodily harm to an individual, or makes physical contact of an insulting or provoking nature with an individual.~~

\*\*\*

**SECTION 2:** This Ordinance shall be in full force and effect from its passage, approval and publication as provided by law.

**PASSED** this \_\_\_\_\_ day of \_\_\_\_\_, 2023, with

\_\_\_\_\_ **ALDERMEN** voting aye      \_\_\_\_\_ **ALDERMEN** abstaining

\_\_\_\_\_ **ALDERMEN** voting nay      \_\_\_\_\_ **ALDERMEN** absent

The **MAYOR** voting aye \_\_\_\_\_, voting nay \_\_\_\_\_, not voting \_\_\_\_\_

\_\_\_\_\_ **SABAN** \_\_\_\_\_ **BARTELTSEN** \_\_\_\_\_ **DESKIN** \_\_\_\_\_ **BERGBOWER**

\_\_\_\_\_ **GILLOGLY** \_\_\_\_\_ **MCDONALD** \_\_\_\_\_ **KAIRIS** \_\_\_\_\_ **PUGH**

\_\_\_\_\_ **MAYOR**

\_\_\_\_\_  
**Steven Streit, Mayor**

**ATTEST:**

\_\_\_\_\_  
**Kathleen Gentile, City Clerk**

### **§ 130.01 ASSAULT.**

A person commits the offense of battery when he intentionally and knowingly, without legal justification, by any means causes bodily harm to an individual, or makes physical contact of an insulting or provoking nature with an individual.

(`79 Code, § 130.001) (Ord. 748, passed 1-17-72) Penalty, see § 10.99

### **§ 130.02 BATTERY.**

A person commits the offense of battery when he intentionally and knowingly, without legal justification, by any means causes bodily harm to an individual, or makes physical contact of an insulting or provoking nature with an individual.

(`79 Code, § 130.005) (Ord. 748, passed 1-17-72) Penalty, see § 10.99



## City Council

### Agenda Memorandum

Item # CD-1

**To:** Mayor & City Council

**From:** Kimberly Phillips, City Planner

**Subject:** Final Development Plan Review for a Restaurant with a Drive-Thru Facility, Lot 1A (Panda Express) in Rose Lockport Center /PZC Case #2023-003

**Date:** Wednesday, May 17, 2023

#### **BACKGROUND/HISTORY**

The applicant Derek Knight on behalf of Panda Express Inc., has submitted an application for approval of Final Development Plans for a stand-alone 2,667 square foot restaurant with drive thru facility on the Lot 1A of Rose Lockport Center (Planned Development). The new restaurant will be operated under the Panda Express, Inc. brands.

The proposed development is located on Lot 1A of Rose Lockport Center (Resubdivision). The proposed restaurant consists of a 2,667 square foot commercial building containing an indoor eating area and kitchen with drive-thru window.

This item was heard by the Plan and Zoning Commission at their regular scheduled meeting on April 11, 2023. The applicant's design team was present to answer questions. Staff presented their report. The Commission heard the report and voted in favor of the new development.

#### **PROS/CONS/ALTERNATIVES**

N/A

#### **RECOMMENDATION**

The Plan and Zoning Commission voted 7-0 to recommend approval of the Final Development Plans for a new 2,667 SF Commercial Building with Drive-thru facility for Lot 1A in Rose Lockport Center for a new Panda Express Restaurant.

#### **ATTACHMENTS**

[Resolution No. 23-043 Final Plan Panda Express](#)

[Exhibit A - Final Site Plan](#)

Exhibit B - Site, Elevations, Materials

Exhibit C - Final Landscape Plan

Exhibit D - Final Site Improvement Engineering

PZC Staff Report - Panda Express

**SPECIFIC CITY COUNCIL ACTION REQUIRED**

Approve Resolution No. 23-043 the Final Development Plans for Lot 1A in Rose Lockport Center (Panda Express Restaurant).

**RESOLUTION NO. 23-043**

**A RESOLUTION APPROVING FINAL DEVELOPMENT PLANS FOR LOT 1A IN ROSE LOCKPORT CENTER (PANDA EXPRESS RESTAURANT)**

**WHEREAS**, Derek Knight, on behalf of Panda Express Inc, is the contract purchaser of the subject property, Lot 1A in Rose Lockport Center, generally located on the west side of Farrell Road, south of 159<sup>th</sup> Street; said property comprising of approximately .998 (more or less) acres, having the following PIN 11-04-24-201-016-0000 hereby legally depicted on **EXHIBIT A**;

**WHEREAS**, the subject property is zoned C2 Community Commercial and is impressed with a Special Use Permit for a Planned Development (including a Drive Thru Facility) pursuant to the Lockport Zoning Ordinance; and

**WHEREAS**, the petitioner has made application for Final Development Plans for the construction of a Panda Express Restaurant with a Drive-thru Facility; and

**WHEREAS**, the City of Lockport Plan & Zoning Commission reviewed the Final Development Plans at the April 11, 2023 meeting and by a 7-0 vote recommended approval.

NOW, THEREFORE, BE IT RESOLVED BY THE MAYOR AND CITY COUNCIL OF THE CITY OF LOCKPORT, WILL COUNTY, ILLINOIS AS FOLLOWS:

**SECTION ONE:** The City Council of the City of Lockport approves the following Final Development Plans:

1. Final Site Plan, dated 3/23/23, prepared by SpaceCo Inc. referred to as “**EXHIBIT A**”
2. Site, Elevations, Materials dated 3/24/23, prepared by Newground. referred to as “**EXHIBIT B**”
3. Final Landscape Plan, dated 3/28/23 prepared by Katherine Tally referred to as “**EXHIBIT C**”
4. Site Improvement Plans for Lot 1A Panda Express, dated 3/23/23 prepared by SpaceCo Inc. referred to as “**EXHIBIT D**”

**SECTION TWO:** The Mayor and City Clerk are authorized and directed to sign any necessary documents in furtherance of this Resolution.

**SECTION THREE:** A certified copy of this Resolution shall be on file with the Office of the City Clerk attached to a copy of the approved Final Development Plan.

**SECTION FOUR:** This Resolution shall be in full force and effect from and after its passage and approval as provided by law.

**PASSED** this \_\_\_\_\_ day of \_\_\_\_\_, 2023, with

\_\_\_\_\_ALDERMEN voting aye      \_\_\_\_\_ALDERMEN abstaining

\_\_\_\_\_ALDERMEN voting nay      \_\_\_\_\_ALDERMEN absent

the MAYOR voting aye \_\_\_\_\_, voting nay \_\_\_\_\_, not voting \_\_\_\_\_

\_\_\_\_\_SABAN    \_\_\_\_\_GILLOGLY    \_\_\_\_\_BERGBOWER    \_\_\_\_\_MCDONALD

\_\_\_\_\_PUGH    \_\_\_\_\_KAIRIS    \_\_\_\_\_DESKIN    \_\_\_\_\_BARTELTSEN

\_\_\_\_\_MAYOR

\_\_\_\_\_  
Steven Streit, Mayor

ATTEST:  
\_\_\_\_\_  
Kathleen Gentile, City Clerk

# SITE INFORMATION

TOTAL SITE AREA (LOT 1A)	43,543 SQ. FT.
IMPERVIOUS SURFACE	31,948 SQ. FT.
PERVIOUS/LANDSCAPE AREA	11,595 SQ. FT.
BUILDING AREA	2,667 GSF
BUILDING COVERAGE	0.06 (2667 / 43543)
PARKING REQUIREMENT 1 SPACE PER 200 SF	13 SPACES (2667 / 200)
PROVIDED PARKING	37 SPACES

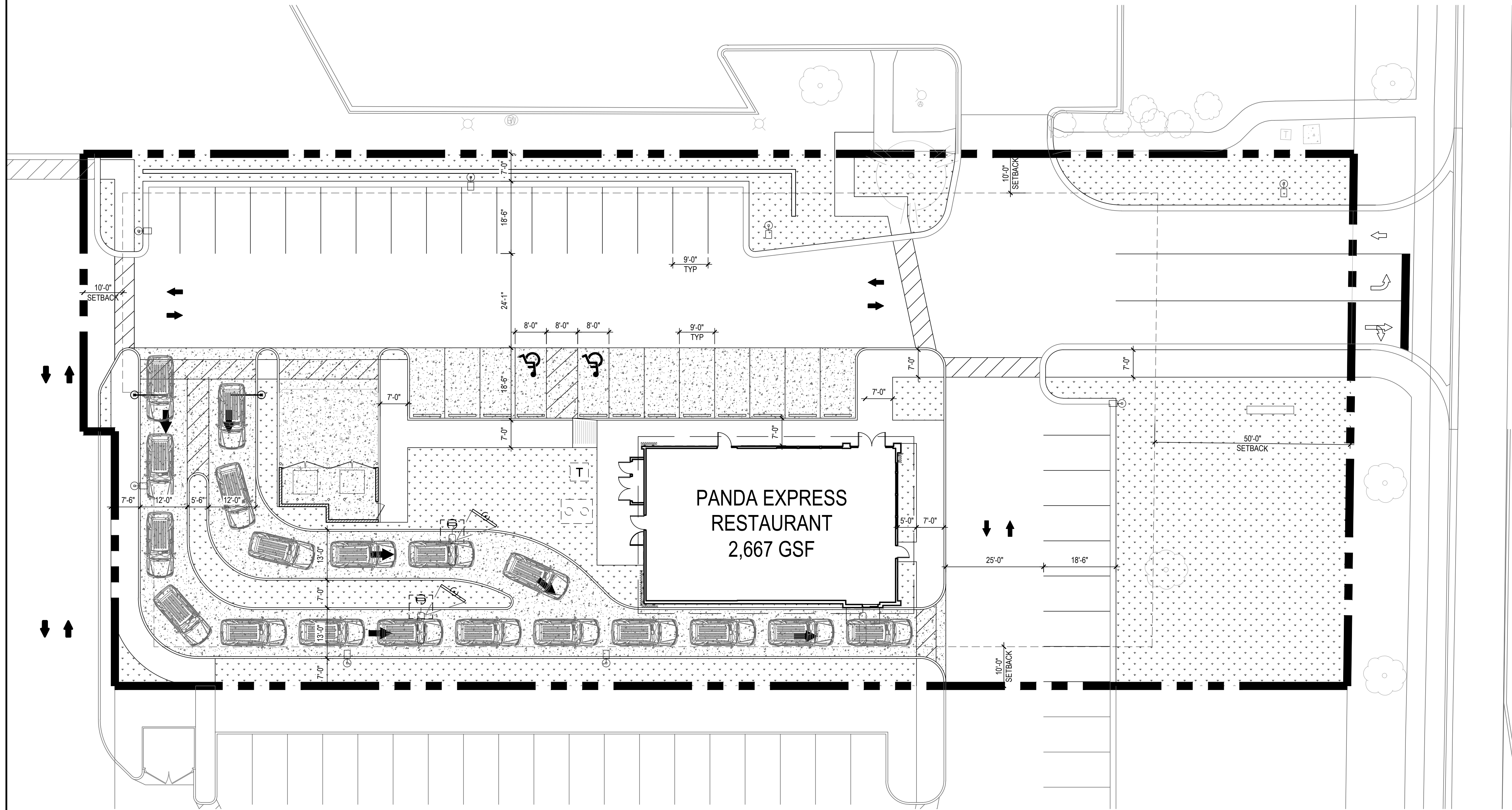

PANDA EXPRESS, INC.  
1683 Walnut Grove Ave.  
Rosemead, California  
91770  
Telephone: 626.799.9898  
Facsimile: 626.372.8288

All ideas, designs, arrangement and plans indicated or represented by this drawing are the property of Panda Express Inc. and were created for use on this specific project. None of these ideas, designs, arrangements or plans may be used by or disclosed to any person, firm, or corporation without the written permission of Panda Express Inc.

### REVISIONS:

### ISSUE DATE:

3/24 | FINAL DEVELOPMENT PLAN

DRAWN BY: RWS

PANDA PROJECT #: S8-24-D22261

PANDA STORE #: D22261

ARCH PROJECT #: Q-51107-0006



NEWGROUND  
15450 S OUTER FORTY DRIVE, SUITE 300  
CHESTERFIELD, MO 63017  
636-898-8100

## PANDA EXPRESS

PANDA HOME 2600  
16000 S FARRELL RD  
LOCKPORT, IL 60441

# SITE-1

SITE PLAN  
FINAL

SITE PLAN 1

Scale= 1/16" = 1'-0" SITE-1

PANDA HOME 2600 R4



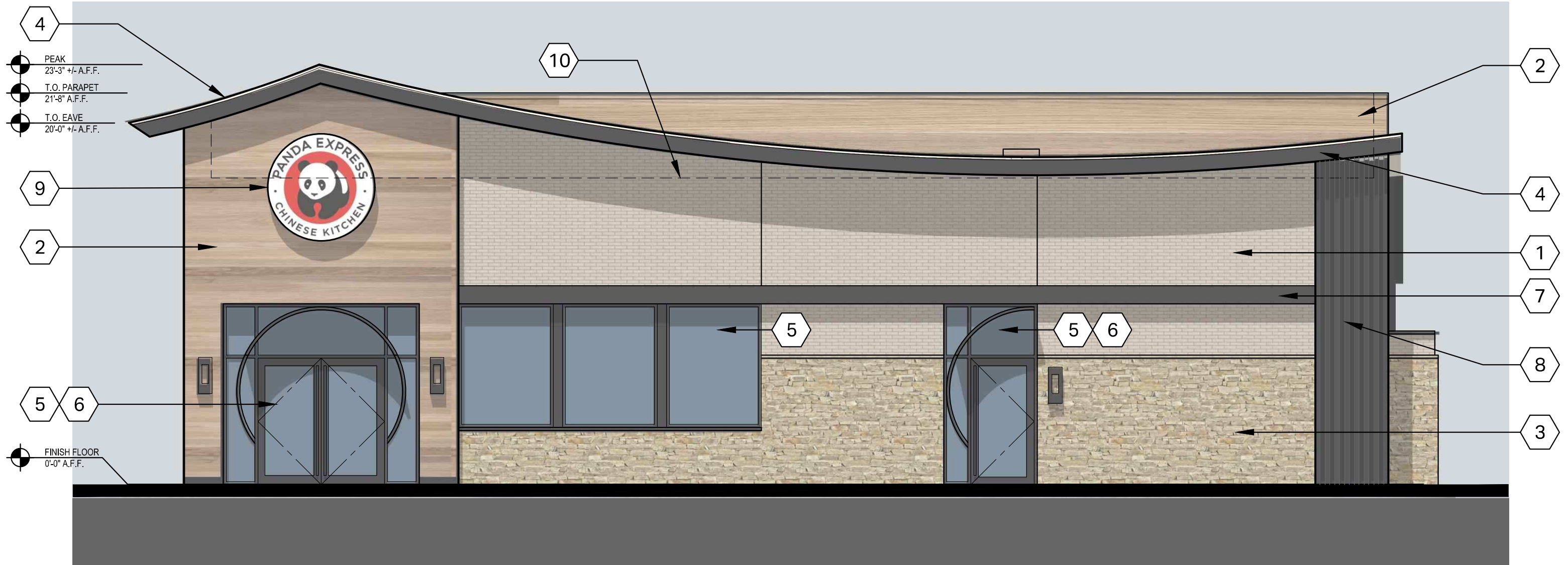

### MATERIAL NOTES

- |                                    |  |                                    |
|------------------------------------|--|------------------------------------|
| ① THIN BRICK, CREAM COLOR          | ⑤ BLACK STOREFRONT GLAZING                 | ⑨ 60" ROUND LOGO SIGN, ILLUMINATED |
| ② WOOD COMPOSITE SIDING            | ⑥ "MOON GATE" AT ENTRANCE DOORS            | ⑩ OUTLINE OF ROOF BEYOND           |
| ③ STONE VENEER (TAN)               | ⑦ METAL "BAND" - BLACK ALUMINUM            |                                    |
| ④ "SWOOP" ELEMENT - BLACK ALUMINUM | ⑧ "TRELLIS" ELEMENT - BLACK/BEIGE ALUMINUM |                                    |



**MATERIAL NOTES**

- |                                    |  |                              |
|------------------------------------|--|------------------------------|
| 1 THIN BRICK, CREAM COLOR          | 5 BLACK STOREFRONT GLAZING                 | 9 WORDMARK SIGN, ILLUMINATED |
| 2 WOOD COMPOSITE SIDING            | 6 STANDING-SEAM METAL ROOFING              | 10 OUTLINE OF ROOF BEYOND    |
| 3 STONE VENEER (TAN)               | 7 METAL "BAND" - BLACK ALUMINUM            | 11 EIFS; BLACK FINE TEXTURED |
| 4 "SWOOP" ELEMENT - BLACK ALUMINUM | 8 "TRELLIS" ELEMENT - BLACK/BEIGE ALUMINUM |                              |

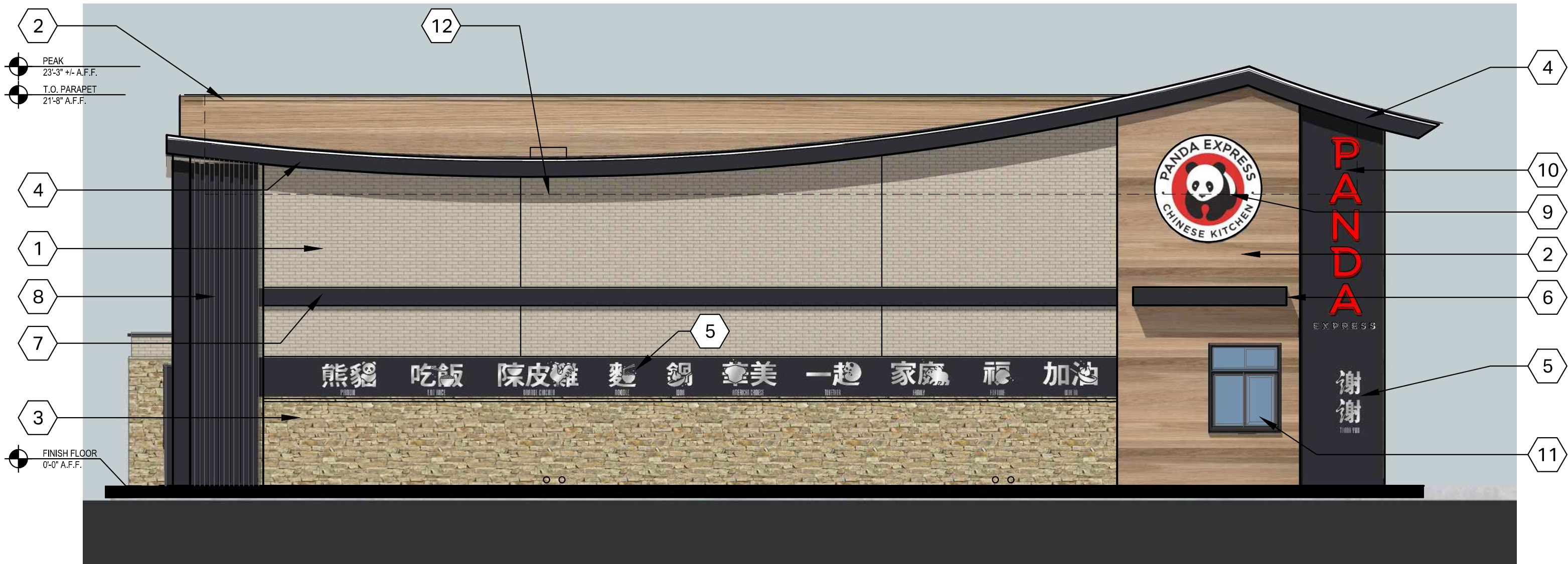

**MATERIAL NOTES**

- |                                    |  |                                     |
|------------------------------------|--|-------------------------------------|
| 1 THIN BRICK, CREAM COLOR          | 5 CHINESE CHARACTER ART                    | 9 60" ROUND LOGO SIGN, ILLUMINATED  |
| 2 WOOD COMPOSITE SIDING            | 6 DRIVE-THRU CANOPY - BLACK ALUMINUM       | 10 VERT. WORDMARK SIGN, ILLUMINATED |
| 3 STONE VENEER (TAN)               | 7 METAL "BAND" - BLACK ALUMINUM            | 11 DRIVE-THRU WINDOW                |
| 4 "SWOOP" ELEMENT - BLACK ALUMINUM | 8 "TRELLIS" ELEMENT - BLACK/BEIGE ALUMINUM | 12 OUTLINE OF ROOF BEYOND           |



**MATERIAL NOTES**

- |                                    |  |                                    |
|------------------------------------|--|------------------------------------|
| 1 THIN BRICK, CREAM COLOR          | 5 UTILITY CLOSET                           | 9 60" ROUND LOGO SIGN, ILLUMINATED |
| 2 WOOD COMPOSITE SIDING            | 6 EIFS; BLACK FINE TEXTURED                | 10 OUTLINE OF ROOF BEYOND          |
| 3 STONE VENEER (TAN)               | 7 METAL "BAND" - BLACK ALUMINUM            |                                    |
| 4 "SWOOP" ELEMENT - BLACK ALUMINUM | 8 "TRELLIS" ELEMENT - BLACK/BEIGE ALUMINUM |                                    |

		East		North		West		South	
		SF	%	SF	%	SF	%	SF	%
Class I	brick	333 SF		401 SF		301 SF		576 SF	
	stone	154 SF		228 SF		109 SF		213 SF	
	glass storefront	139 SF		277 SF		0 SF		20 SF	
	wood composite siding	51 SF		330 SF		110 SF		326 SF	
Class I Total		677 SF	81.3%	1236 SF	86.7%	520 SF	60.3%	1135 SF	80.3%
Class II	synthetic stucco / EIFS (accent only)	76 SF		72 SF		142 SF		162 SF	
	Class II Total		76 SF	9.1%	72 SF	5.1%	142 SF	16.5%	162 SF
Class III	metal panel or metal door	80 SF		117 SF		200 SF		117 SF	
	Class III Total		80 SF	9.6%	117 SF	8.2%	200 SF	23.2%	117 SF
Grand Total		833 SF	100%	1425 SF	100%	862 SF	100%	1414 SF	100%

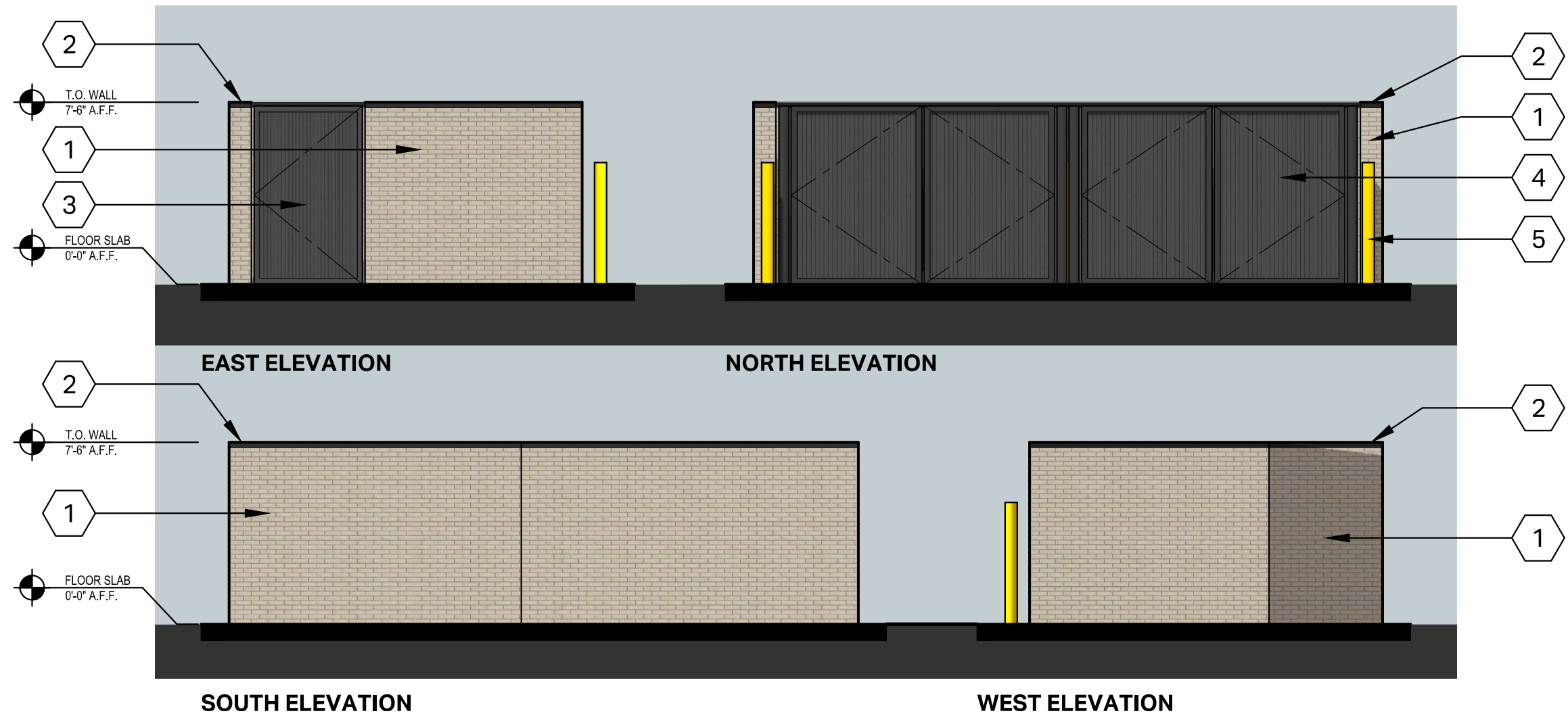

**MATERIAL NOTES**

- 1 THIN BRICK, CREAM COLOR
- 2 WALL COPING - BLACK ALUMINUM
- 3 PEDESTRIAN GATE - STEEL, BLACK PAINT
- 4 TRASH GATE - STEEL, BLACK PAINT
- 5 PIPE BOLLARD - STEEL, SAFETY YELLOW



## fiberon Wildwood™ Cladding

### Technical Data Sheet

Fiberon Wildwood composite cladding provides the unrivaled beauty and warmth of wood combined with the durability of high-performance, low-maintenance composite materials. The durable composite core ensures exceptional resistance to rotting, cracking, insects and decay, and our exclusive PermaTech® cap layer protects against fading and staining.

#### Product Program

Open-Joint Profile				
	Nominal	1 in. x 6 in.	1 in. x 8 in.	1 in. x 12 in.
	Actual	0.75 in. x 6 in.	0.75 in. x 7.75 in.	0.75 in. x 11.25 in.
	Length	12 ft., 16 ft. or 20 ft.	12 ft.	12 ft.

#### Colors and Finishes

#### Eden Collection

Tupelo	Meranti	Koa	Mora	Wenge

#### Sahara Collection

Mulga	Sumac	Palo	Bamboo

#### Product Properties Chart

Property	Test Method	Result
Flexural Modulus MOE	ASTM 6109	321,000 PSI
Flexural Strength MOR	ASTM 6109	4950 PSI
Coefficient of Thermal Expansion	ASTM D6341	1.99 x 10 <sup>-5</sup> in/in/deg F
Decay Resistance (Brown & White Rot)	AWPA E10-12	Pass
Termites (Formosan Subterranean)	AWPA E1-09 (ASTM D3345)	Pass
Screw Head Pull-Through	ASTM E330	696 lbf (not > 800 lbs)
Flame Spread	ASTM E-84	FSI 65 (Class B)
Smoke Development Index	ASTM E-84	200

Notes:  
1 = Co-Extruded Wood Plastic Composite cladding board

Property	Test Method	Result
Weight per Lineal Foot (12-in. width)	N/A	3.9 lbs/ft
Weight per Lineal Foot (8-in. width)	N/A	2.6 lbs/ft
Weight per Lineal Foot (6-in. width)	N/A	2.2 lbs/ft

#### Codes and Certifications

- FSI 65, Class B rated in ASTM E84 testing.
- Meets requirements of California Office of the State Fire Marshal SFM 12-7A-1 testing in a wall assembly.
- BML Listed - Exterior Wall Siding and Sheathing for Wildland Urban Interface (WUI) (8140-2045:0504)

#### Green Statistics

- Fiberon® Wildwood™ composite cladding is a cost-effective green building solution.
- Made with 94% pre- and post-consumer recycled content.
- Combines all the best qualities of recycled wood with the long-lasting resilience of recycled plastic.
- Blending these two materials together is the reason why our products last, and why they're sustainable from start to finish.

#### Storage Considerations

Proper storage and handling of Fiberon cladding is necessary for keeping the product intact and reducing safety hazards. Best practices for the handling and storage of cladding boards can be downloaded at [https://fiberon.widen.net/s/dxxiktgxb/lit\\_clad\\_storage-and-handling-best-practices](https://fiberon.widen.net/s/dxxiktgxb/lit_clad_storage-and-handling-best-practices)

#### Installation Considerations

Fiberon Wildwood composite cladding contributes to effective moisture management. Visit [cladding.fiberondecking.com/technical/moisture-management](https://cladding.fiberondecking.com/technical/moisture-management) to learn more about high performance rainscreen systems.

#### Warranty Information

Fiberon Wildwood composite cladding meets comprehensive testing standards and is backed by an industry-leading 50-year warranty. Note: See your Fiberon seller or visit [fiberoncladding.com/technical/warranty](https://fiberoncladding.com/technical/warranty) for details on limited warranties and exclusions.





PANDA EXPRESS, INC.  
1683 Walnut Grove Ave.  
Rosemead, California  
91770  
Telephone: 626.799.9898  
Facsimile: 626.372.8288

All ideas, designs, arrangement and plans indicated or represented by this drawing are the property of Panda Express Inc. and were created for use on this specific project. None of these ideas, designs, arrangements or plans may be used by or disclosed to any person, firm, or corporation without the written permission of Panda Express Inc.

REVISIONS:

ISSUE DATE:

DRAWN BY: FAL  
PANDA PROJECT #: S8-24-D22261  
PANDA STORE #: D22261  
ARCH PROJECT #: Q-51107-0006

PRELIMINARY DRAWINGS  
NOT FOR CONSTRUCTION



PANDA EXPRESS  
PANDA HOME 2600  
16000 S FARRELL RD  
LOCKPORT, IL 60441

PHOTOMETRICS PLAN

E1

### HOWARD LIGHTING PRODUCTS

## VL Series

**Versalite LED Wallpack**  
12, 30, and 50W (120-277V)

**Project:** \_\_\_\_\_  
**Contract:** \_\_\_\_\_  
**Approved by:** \_\_\_\_\_

**Applications:**  
Wall Mount: • Loading Docks • Entrances • Parking Areas • Perimeter • Landscaping  
Flood Applications: • Storage • Building Facade • Daylight • Security Lighting

**Warranty and Listings:**  
• 5-year warranty on all electronics and housing.  
• 50,000 hours maintenance-free operation to L70.  
• PSE listed.  
• Complies with FCC Part 15, Class B.  
• Complies with ENEC 1200 S.S. surge immunity (1kV).• 5-year warranty on all electronics and housing.

**Mounting Options:**  
• Standard  
• Flush Mount  
• Surface Mount

**Dimensions:**  
L: 12, 30, 50  
W: 3.0, 3.5, 3.9  
H: 1.3, 1.5, 1.8

**Ordering Information:**

Model	Watts (W)	Lumens	Lm/W	SCC/CRI	Voltage	Dimming Status
VL12	12	1,320	110	8000K CRI 81	120-277V	Net
VL30	30	3,240	108	8000K CRI 81	120-277V	Net
VL50	50	5,250	105	8000K CRI 81	120-277V	Net

IES, UL LISTED, DLC, 5 YEAR WARRANTY

Zip File, Installation Instructions

Specifications subject to change without notice. © Howard Lighting Products | 300 Eastview Drive | Lowell, MA 01853 | 800.866.5963 | 978.667.2200 | 978.667.2200 | www.HowardLightingProducts.com

### ATLANTIS 1649BZ-LED

LARGE WALL MOUNT "ANTERN"  
Atlanta features a minimalist design for the ultimate urban application. Constructed of cast aluminum and the compact, ultra-thin profile is the solution to any complex topography.

**DETAILS:**  
Finish: Bronze  
Material: Extruded Aluminum Body  
Glass: Etched Glass

**DIMENSIONS:**  
Height: 27"  
Width: 12"  
Depth: 12"  
Back Plate: 4" W x 6.75" D  
Extension: 4"  
Top to Outlet: 25.75"

**LIGHT SOURCE:**  
Light Source: Integrated LED  
LED Name: 3030A LED  
Voltage: 120V  
Color Temp: 3000K  
CRI: 80  
Beam Spread: 120°  
Beam Angle: 120°  
Beam Spread: 120°  
Beam Angle: 120°  
Beam Spread: 120°  
Beam Angle: 120°

**PRODUCT DETAILS:**  
• Suitable for use in wet (outdoor direct rain or sprinkler) locations as defined by NEC and CEC. Meets United States UL Underwriters Laboratories & CSA Canadian Standards Association Product Safety Standards.  
• Fixture is dark grey compliant and engineered to minimize light glare upward into the night sky.  
• Fixture is ADA compliant and adheres to the standards and guidelines listed by the Americans with Disabilities Act.  
• Meets California Energy Commission Title 24 Part 6.16 regulations.  
• Equipped with a 120/277V universal driver, 0-10 dimming.  
• 2 year finish warranty.  
• LED components carry a 5-year limited warranty.  
• Bold lines and a clean, minimalist style complement contemporary architecture.

**HINKLEY**  
3000 The Oak Parkway  
Parsippany, NJ 07054  
PHONE: (408) 523-5900  
Fax: 973-848-8939  
hinkley.com

### STATISTICS

Description	Symbol	Avg	Max	Min	Max/Min	Avg/Min
PANDA SITE	+	1.0 fc	17.4 fc	0.0 fc	N/A	N/A

### LUMINAIRE SCHEDULE

Symbol	Label	Qty	Catalog Number	Description	Lamp	File	Lumens	LLF	Watts
□	A	5	DSX1 LED P1 30K 70CRI BLC3 EGS	D-Series Size 1 Area Luminaire P1 Performance Package 3000K CCT 70 CRI Type 3 Extreme Backlight Control External Glare Shield		A_DSX1_LED_PT_30K_70CRI_BLC3_EGS.lvs	Absolute	1.00	50.9
□	B	2	DSX1 LED P1 30K 70CRI LCCO	D-Series Size 1 Area Luminaire P1 Performance Package 3000K CCT 70 CRI Left Corner Cutoff Extreme Backlight Control		B_DSX1_LED_PT_30K_70CRI_LCCO.lvs	Absolute	1.00	50.9
□	C	2	DSX1 LED P1 30K 70CRI BLC4 EGS	D-Series Size 1 Area Luminaire P1 Performance Package 3000K CCT 70 CRI Type 4 Extreme Backlight Control External Glare Shield		C_DSX1_LED_PT_30K_70CRI_BLC4_EGS.lvs	Absolute	1.00	50.9
□	L90BL	4	1649BZ-LED	Hinkley Atlantis Wall Lantern - Large	2 x COL-35	1649BZ-LED.lvs	Absolute	1.00	10.1
○	L85	1	VL305	Howard Lighting - Versalite LED Wallpack 30W		IES_VL305.lvs	Absolute	1.00	27.9

BY SELLER (LFI / SHELBY LLC)

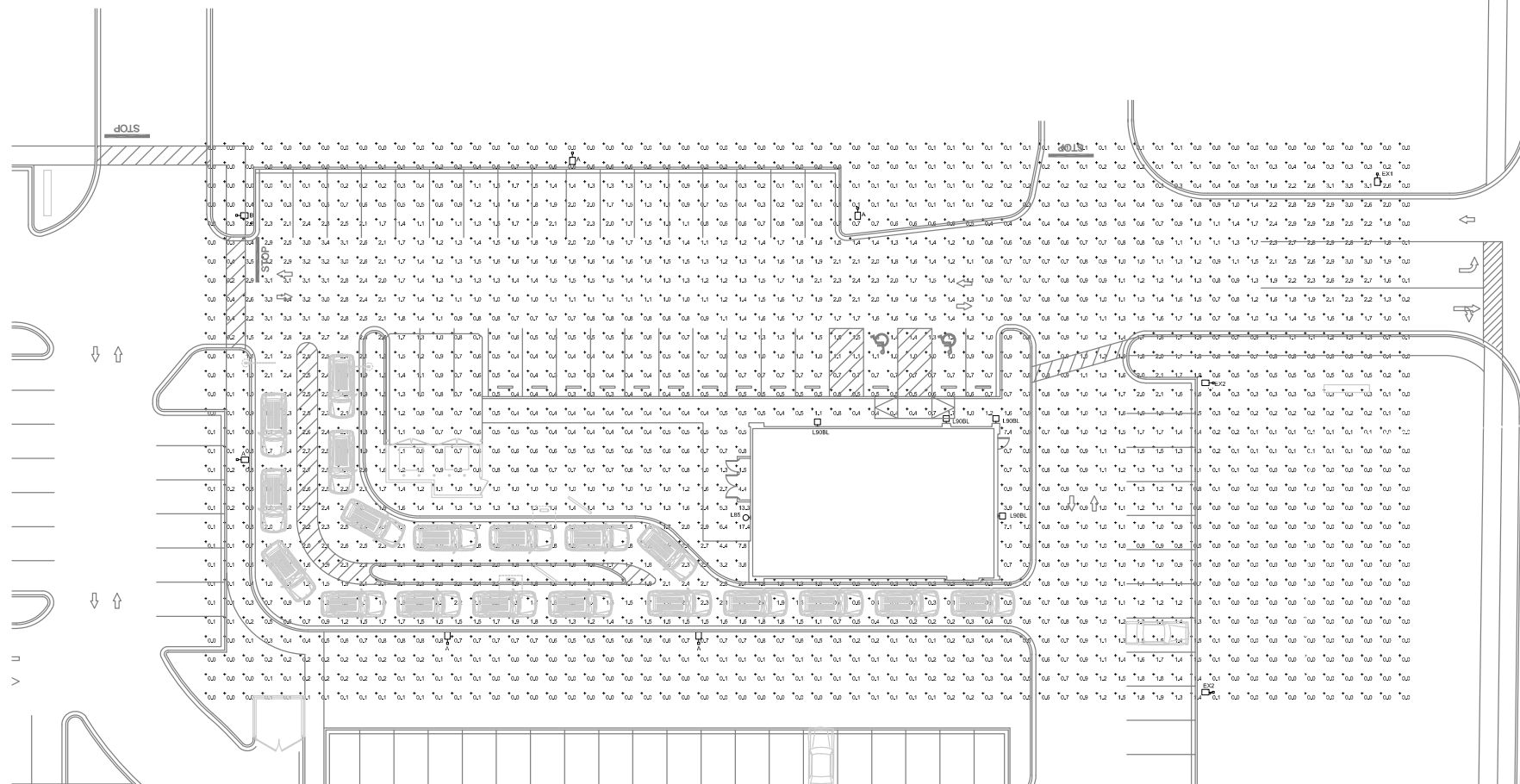

1 PHOTOMETRIC PLAN  
Scale: 1" = 20'-0"



LEGEND

—	EXISTING
—	NEW WORK
⊕	NEW TO EXISTING CONNECTION

Code Summary

SIGN	LOCATION	TYPE	HEIGHT	WIDTH	ALLOWED	PROPOSED	BALANCE
S1	SHORT STOREFRONT	STACKED RED LETTERSET	2'-5"	13'-0 1/8"	51.25	49.88	1.37
S2	LONG STOREFRONT	LOCKUP LOGO	6'-0"	6'-0"	65	36	29
S3	DRIVE THRU ELEVATION	LOCKUP LOGO	6'-0"	6'-0"	65	36	29
S4	DRIVE THRU ELEVATION	LETTERSET	9'-10 3/8"	2'-8 1/8"	29	24.9	41
S5	REAR ELEVATION	LOCKUP LOGO	6'-0"	6'-0"	41	36	5
S10	STREET	MONUMENT	6'-0"	4'-0"	64	19.25	44.75

Code Allowance	Elevation	Allowed	Elevation	Allowed
Primary wall 1.25sf per ft of building wall width; secondary walls at 1sf per ft	Long Storefront	65 SF	Drive Thru	65 SF
	Short Storefront	51.25 SF	Rear	41 SF

Site Plan

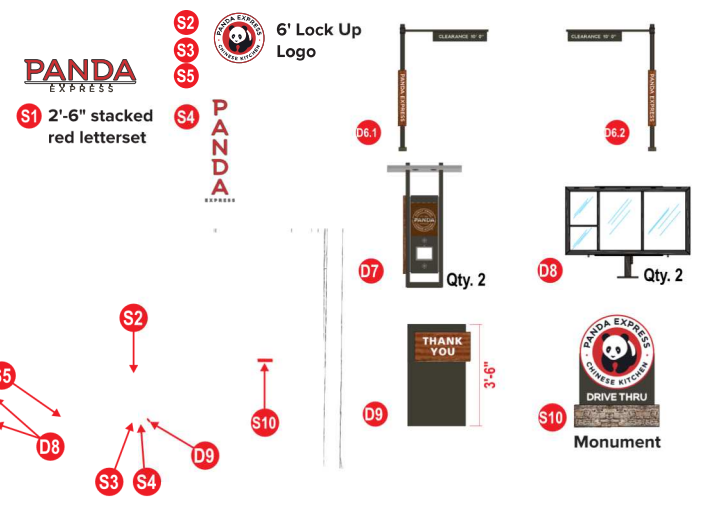
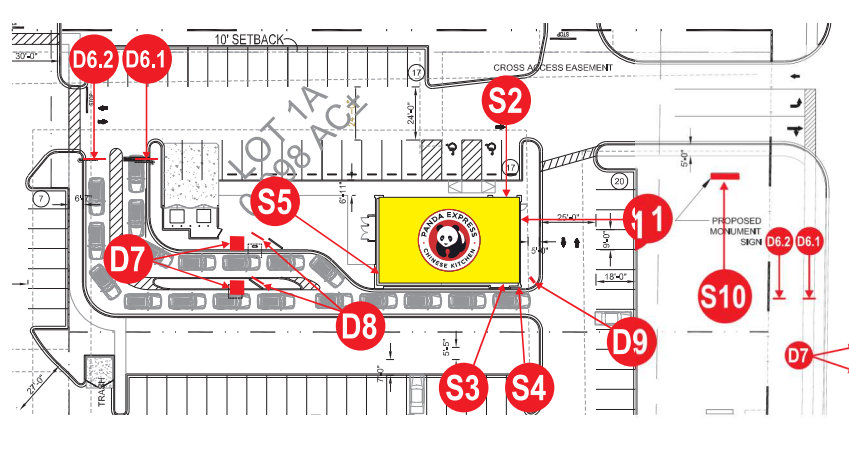

Drawing # C75197  
 Priority  
 Revisions: [Table with revision details]  
 Date: 06.22.2022  
 City/State: Lockport, IL  
 Address: 301 Farrell Rd - Lot 1A

Elevations

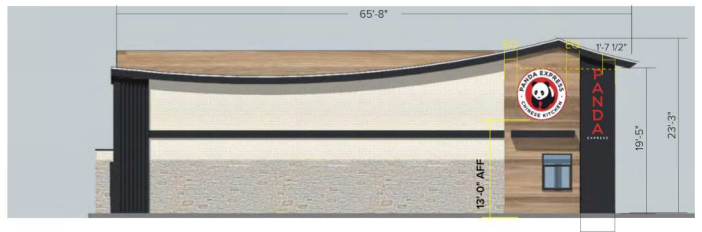

SIGN	LOCATION	TYPE	HEIGHT	WIDTH	ALLOWED	PROPOSED	BALANCE
S3	DRIVE THRU ELEVATION	LOCKUP LOGO	6'-0"	6'-0"	90.81	65	29
S4	DRIVE THRU ELEVATION	LETTERSET	9'-10 3/8"	2'-8 1/8"	29	24.9	41

Revisions: [Table with revision details]  
 Date: 06.22.2022  
 City/State: Lockport, IL  
 Address: 301 Farrell Rd - Lot 1A

Elevations



SIGN	LOCATION	TYPE	HEIGHT	WIDTH	ALLOWED	PROPOSED	BALANCE
S5	REAR ELEVATION	LOCKUP LOGO	6'-0"	6'-0"	41	36	5

Elevations

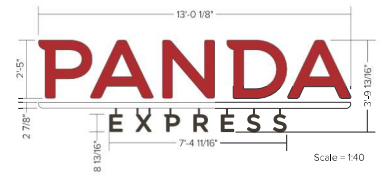

SIGN	LOCATION	TYPE	HEIGHT	WIDTH	ALLOWED	PROPOSED	BALANCE
S1	SHORT STOREFRONT	STACKED RED LETTERSET	2'-5"	13'-0 1/8"	51.25	49.88	1.37

Revisions: [Table with revision details]  
 Date: 06.22.2022  
 City/State: Lockport, IL  
 Address: 301 Farrell Rd - Lot 1A

Elevations

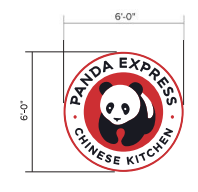

SIGN	LOCATION	TYPE	HEIGHT	WIDTH	ALLOWED	PROPOSED	BALANCE
S2	LONG STOREFRONT	LOCKUP LOGO	6'-0"	6'-0"	65	36	29

S10 Custom Illuminated Monument - (Qty: 1)

Install new internally illuminated double-faced monument sign. Refer to site plan for exact location. Note: Silt of Landscaping required at base of sign. To be provided by others.



COLOR SPECIFICATIONS

- TOP CLADDING**  
080" Aluminum sign cladding  
Color: To match PMS Black 7C
- RETAINER**  
080" Routed aluminum ring with 040" welded return  
Color: To match PMS Black 7C on return edge only  
To match PMS 71C on face
- FACE**  
120" 0.0250" aluminum cladding  
Color: To match PMS Black 7C
- BASE/SKIRT**  
Elastofoam Extruded Extrusion Mesquite
- ILLUMINATED FINISHED EDGE**  
Buyer's Selection  
3M Scotchlite D3636-23 Red film  
3M #3636SPB88-2m
- "DRIVE THRU/FRU" CO**  
Buyer's Selection  
3M Scotchlite D3636-23 Red film  
3M #3636SPB88-2m



PANDA EXPRESS, INC.  
 1683 Walnut Grove Ave.  
 Rosemead, California  
 91770  
 Telephone: 626.799.9898  
 Facsimile: 626.372.8288

All ideas, designs, arrangement and plans indicated or represented by this drawing are the property of Panda Express Inc. and were created for use on this specific project. None of these ideas, designs, arrangements or plans may be used by or disclosed to any person, firm, or corporation without the written permission of Panda Express Inc.

REVISIONS:

NO.	DESCRIPTION

ISSUE DATE: 3/24 FINAL DEVELOPMENT PLAN

DRAWN BY: RWS

PANDA PROJECT #: S8-24-D22261  
 PANDA STORE #: D22261  
 ARCH PROJECT #: Q-51107-0006

**NEWGROUND**  
 15450 S OUTER FORTY DRIVE, SUITE 300  
 CHESTERFIELD, MO 63017  
 636-898-8100

**PANDA EXPRESS**  
 PANDA HOME 2600  
 16000 S FARRELL RD  
 LOCKPORT, IL 60441

**SIGN-1**  
 SIGNAGE PLAN

# FINAL LANDSCAPE PLAN

SCALE: 1/16" = 1'-0"

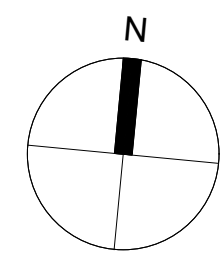

NOTE: PER SPACECO, INC., CONSULTING ENGINEERS, THE LOT HAS AN IMPERVIOUS CALCULATION OF 72.7%, AND A C VALUE OF 0.79

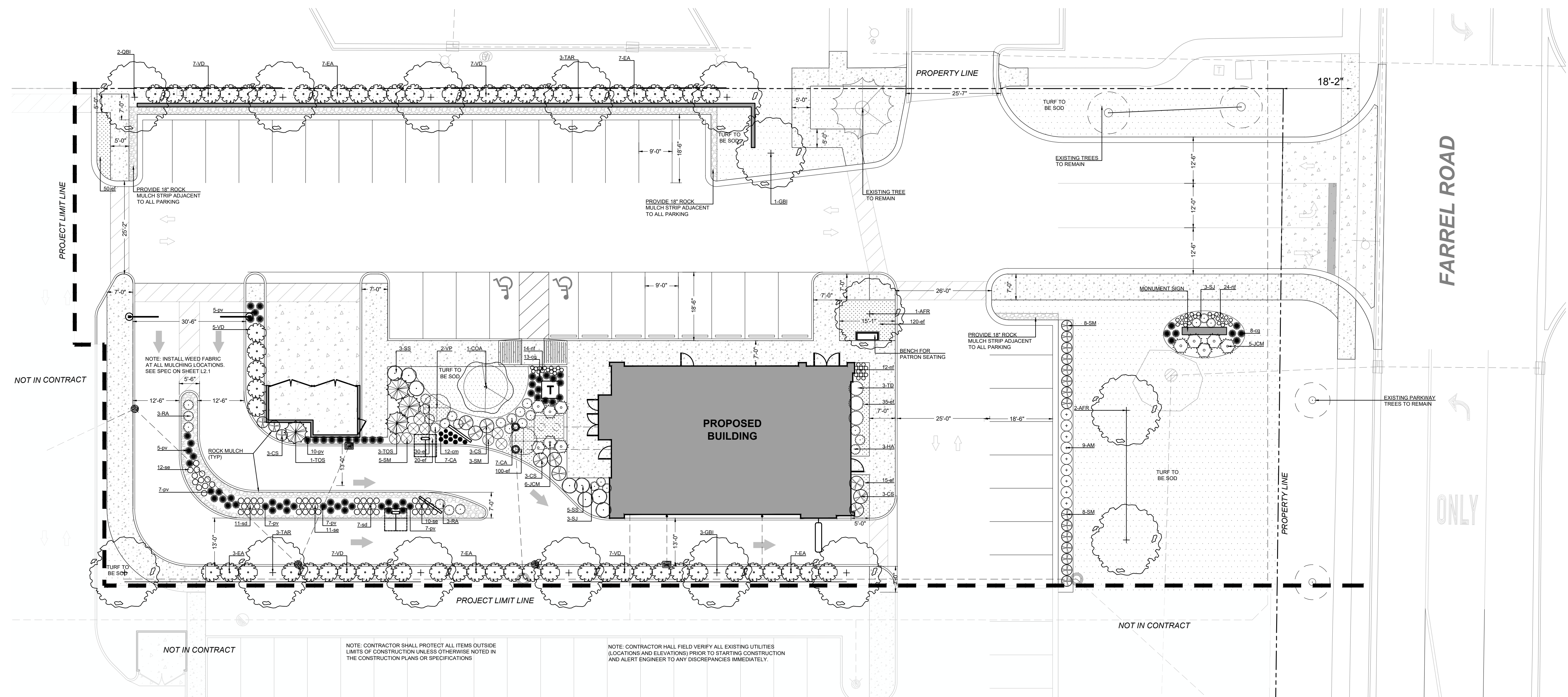

Master Plant List						
Symbol	Quantity	Botanical Name	Common Name	Size	Origin	Notes
<b>Shade Trees</b>						
AFR	3	ACER X FREEMANII 'AUTUMN BLAZE'	AUTUMN BLAZE FREEMAN MAPLE	3" BB		MOIST
GBI	4	GINKGO BILOBA	GINKGO	3" BB		URBAN, MALE SPEC. ONLY
QBI	3	QUERCUS BICOLOR	SWAMP WHITE OAK	3" BB	NATIVE	
TAR	6	TILIA AMERICANA 'REDMOND'	REDMOND AMERICAN LINDEN	3" BB	NATIVE	URBAN, MOIST
<b>Evergreen Trees</b>						
TOS	4	THUJA OCCIDENTALIS 'SMARAGD'	EMERALD GREEN ARBORVITAE	6" BB	NATIVE	
<b>Ornamental Trees</b>						
COA	1	CORNUS ALTERINFOLIA	PAGODA DOGWOOD	8" BB	NATIVE	
<b>Evergreen Shrubs</b>						
JCM	11	JUNIPERUS CHINENSIS 'MINT JULIP'	MINT JULIP SPREADING JUNIPER	24" BB		
TD	3	TAXUS x MEDIA 'DENSII'	DENSE YEW	24" BB		
<b>Deciduous Shrubs</b>						
AM	9	ARONIA MELANOCARPA 'IROQUOI'S BEAUTY'	IROQUOI'S BEAUTY BLACK CHOKEBERRY	24" BB	NATIVE	
CA	15	CLETHRA ALNIFOLIA 'HUMMINGBIRD'	HUMMINGBIRD CLETHRA	5 GAL		
CS	12	CORNUS SERICEA 'ISANTI'	ISANTI RED TWIG DOGWOOD	24" BB	NATIVE	
EA	31	EUONYMUS ALATA 'COMPACTA'	DWARF BURNING BUSH	36" BB		
HA	3	HYDRANGEA ARBORESCENS	ANNABELLE HYDRANGEA	5 GAL	NATIVE	
RA	6	RHUS AROMATICA 'GRO LOW'	GRO LOW SUMAC	5 GAL	NATIVE	
SS	8	SORBARIA SORBIFOLIA 'SEM'	SEM URAL FALSE SPIREA	24" BB		
SJ	6	SPIREA JAPONICA 'LITTLE PRINCESS'	LITTLE PRINCESS SPIREA	24" BB		
SM	24	SYRINGA MEYER 'PALBIN'	DWARF KOREAN LILAC	24" BB		
VD	33	VIBURNUM DENTATUM 'CHICAGO LUSTRE'	CHICAGO LUSTRE ARROWWOOD VIBURNUM	48" BB	NATIVE	
VP	2	VIBURNUM PLICATUM 'TOMENTOSUM 'MARISSII''	DOUBLEFILE VIBURNUM	36" BB		
<b>Groundcover</b>						
ef	350	EUONYMUS FORTUNEI 'COLORATUS'	PURPLELEAF WINTERCREEPER	3" POTS		
<b>Perennials</b>						
sd	41	SEDUM 'BACK IN BLACK'	DARK PURPLE SEDUM	1 GAL		24", PURPLE
se	41	SEDUM SPECTABILE 'AUTUMN JOY'	AUTUMN JOY SEDUM	1 GAL		24", PINK
nf	40	NEPETA X FAASSENII	FAASSENS CATMINT	1 GAL		12" LAVENDER
<b>Grasses</b>						
cg	21	CALAMAGROSTIS ACUTIFLORA 'KARL FOERSTER'	FEATHER REED GRASS	3 GAL		3'
cm	12	CAREX MORROWII 'ICE DANCE'	ICE DANCE SEDGE	1 GAL		18", PART SHADE
pv	48	PANICUM VIRGATUM 'NORTH WIND'	SWITCH GRASS	3 GAL		4'

## GENERAL CONSTRUCTION NOTES

- REQUIRED LANDSCAPE MATERIAL SHALL SATISFY AMERICAN ASSOCIATION OF NURSERYMEN STANDARDS AND BE STAKED, WRAPPED, WATERED AND MULCHED PER ORDINANCE.
- BEFORE ANY EXCAVATION ON THE SITE, CALL TO LOCATE ANY EXISTING UTILITIES ON THE SITE. THE CONTRACTOR SHALL FAMILIARIZE HIM/HERSELF WITH THE LOCATIONS OF ALL BURIED UTILITIES IN THE AREAS OF WORK BEFORE STARTING OPERATIONS. THE CONTRACTOR SHALL BE LIABLE FOR THE COST OF REPAIRING OR REPLACING ANY BURIED CONDUITS, CABLES OR PIPING DAMAGED DURING THE INSTALLATION OF THIS WORK.
- FOUR FOOT HIGH FENCING OR OTHER RIGID MATERIAL IS TO BE ERRECTED AROUND THE DRIP-LINE OF ALL TREES TO BE SAVED.
- PLANT QUANTITIES ON PLANT LIST INTENDED TO BE A GUIDE. ALL QUANTITIES SHALL BE CHECKED AND VERIFIED ON PLANTING PLAN. ANY DISCREPANCIES SHALL BE DISCUSSED WITH THE LANDSCAPE ARCHITECT.
- ANY DEVIATIONS FROM OR MODIFICATIONS TO THIS PLAN SHALL BE APPROVED BY THE LANDSCAPE ARCHITECT PRIOR TO INSTALLATION.
- CONTRACTOR TO NOTIFY LANDSCAPE ARCHITECT UPON DELIVERY OF PLANT MATERIAL TO THE SITE. LANDSCAPE ARCHITECT RESERVES THE RIGHT TO REJECT ANY PLANT MATERIAL THAT DOESN'T MEET STANDARDS OR SPECIFICATIONS OF THE PROJECT.
- ALL PLANT MATERIAL TO BE INSTALLED PER THE PLANTING DETAILS PROVIDED ON THIS PLAN SET.
- ALL BED EDGES TO BE WELL SHAPED, SPADE CUT, WITH LINES AND CURVES AS SHOWN ON THIS PLAN SET.
- ALL PLANTING BEDS TO BE PREPARED WITH PLANTING MIX: 50% TOPSOIL, 50% SOIL AMENDMENTS (3 PARTS PEATMOSS, 1 PART COMPOST, 1 PART SAND)
- ALL PARKING LOT ISLANDS SHALL BE BACKFILLED WITH THE FOLLOWING: 2" OF BLENDED GARDEN SOIL MIX (60% TOPSOIL, 30% COMPOST, 10% SAND) OR 6" OF ONE STEP BY MIDWEST TRADING, TOP DRESSED AND TILLED INTO 18" OF TOPSOIL.
- ALL SPECIFIED LANDSCAPE MATERIAL INDICATED ON THE CONSTRUCTION DOCUMENTS WILL BE REQUIRED TO BE MAINTAINED THROUGHOUT THE LIFE OF THE PROJECT AND MUST BE REPLACED SHOULD IT DIE OR BECOME DAMAGED.
- ALL PLANT MATERIAL SHALL HAVE A ONE YEAR GUARANTEE FROM SUBSTANTIAL COMPLETION AS DETERMINED BY THE LANDSCAPE ARCHITECT, AND SHALL BE REPLACED SHOULD IT DIE WITHIN THAT PERIOD.
- PROTECT STRUCTURES, SIDEWALKS, PAVEMENTS AND UTILITIES TO REMAIN FROM DAMAGE CAUSED BY SETTLEMENT, LATERAL MOVEMENT, UNDERMINING, WASHOUTS AND OTHER HAZARDS CAUSED BY SITE IMPROVEMENT OPERATIONS.
- ALL LAWN AREAS TO BE SEEDDED WITH STANDARD TURF GRASS SEED AND COVERED WITH EROSION CONTROL BLANKET. UNLESS OTHERWISE SPECIFIED ON THE PLAN.
- CAREFULLY MAINTAIN PRESENT GRADE AT BASE OF ALL EXISTING TREES TO REMAIN. PREVENT ANY DISTURBANCE OF EXISTING TREES INCLUDING ROOT ZONES. USE TREE PROTECTION BARRICADES WHERE INDICATED. PROTECT EXISTING TREES TO REMAIN AGAINST UNNECESSARY CUTTING, BREAKING OR SKINNING OF ROOTS, BRUISING OF BARK OR SMOTHERING OF TREES. DRIVING, PARKING, DUMPING, STOCKPILING AND/OR STORAGE OF VEHICLES, EQUIPMENT, SUPPLIES, MATERIALS OR DEBRIS ON TOP THE ROOT ZONES AND/OR WITHIN THE DRIPLINE OF EXISTING TREES OR OTHER PLANT MATERIAL TO REMAIN IS STRICTLY PROHIBITED.
- THE CONTRACTOR AT ALL TIMES SHALL KEEP THE PREMISES ON WHICH WORK IS BEING DONE, CLEAR OF RUBBISH AND DEBRIS. ALL PAVEMENT AND DEBRIS REMOVED FROM THE SITE SHALL BE DISPOSED OF LEGALLY.
- ALL WORK AND OPERATIONS SHALL COMPLY WITH ALL APPLICABLE FEDERAL, STATE AND LOCAL CODES AND ORDINANCES.

**Kathryn Talty**  
landscape architecture

Winnetka, Illinois 60093  
847.612.1514  
www.kmtaltdesign.com

no.	revision	description	initial	date
1	ISSUED FOR REVIEW		KMT	01-30-23
2	PER CITY COMMENTS		KMT	03-06-23
3	PER CITY COMMENTS		KMT	03-28-23

**PANDA EXPRESS**  
LOCKPORT, IL

FINAL LANDSCAPE PLAN  
MASTER PLANT LIST  
CONSTRUCTION NOTES

date: 01-10-23  
drawn: DW  
checked: KMT

job no.

**23010**

sheet no.

**L 1.1**



### Pro 5 Weed Barrier



DeWitt Pro 5 Weed Barrier is a woven, needle-punched polypropylene fabric for commercial grade weed control. Specified by leading architects, the fabric is designed to allow air, water, and nutrients through. The fabric will not rot or mildew, and is formulated to resist uv degradation.

Property	Test Method	Unit	Minimum Average Roll Value
Woven Material			Polypropylene
Fiber Backing			Polyester
Color			Black with Gold Stripe every 12"
Construction Weave			15 x 10 or 10 x 15
Weight	ASTM D 5261	OZ/SY	5.0 Scrim 2.8 Cap 2.2
Grab Tensile Strength	ASTM D 4632	LBS	Warp 80 Weft 65
Grab Elongation	ASTM D 4632	%	Warp 15 Weft 15
Trapezoid Tear	ASTM D 4533	LBS	Warp 35 Weft 30
Puncture	ASTM D 6241	LBS	300
Water Permeability	ASTM D 4491	GAL/MIN/SF	10
Ultraviolet Exposure	ASTM D 4355	% Strength Retained	>70% after 2500 Hrs Carbon Arc Exposure

THE ABOVE IS THE MINIMUM STANDARD. OTHER BRANDS MAY BE SUBSTITUTED AS LONG AS THE SPECIFICATIONS ARE MET OR EXCEEDED. HOWEVER, ANY SUBSTITUTION MUST BE SUBMITTED BY THE CONTRACTOR FOR PANDA PM APPROVAL, PRIOR TO INSTALLATION.

## LANDSCAPE MAINTENANCE SPECIFICATIONS

### LANDSCAPE MAINTENANCE SPECIFICATIONS

The Contractor shall provide a separate bid, maintenance for a period of 1 year after final acceptance of the project landscaping. The Contractor must be able to provide continued maintenance if requested by the Owner or provide the name of a reputable landscape contractor who can provide maintenance.

#### STANDARDS

All landscape maintenance services shall be performed by trained personnel using current, acceptable horticultural practices. All work shall be performed in a manner that maintains the original intent of the landscape design.

All chemical applications shall be performed in accordance with current county, state and federal laws, using EPA registered materials and methods of application. These applications shall be performed under the supervision of a Licensed Certified applicator.

#### APPROVALS

Any work performed in addition to that which is outlined in the contract shall only be done upon written approval by the Owner's Representative.

All seasonal color selections shall be approved by the Owner's Representative prior to ordering and installation.

#### SOIL TESTING

The maintenance contractor shall perform soil tests as needed to identify imbalances or deficiencies causing plant material decline. The owner shall be notified of the recommendation for approval, and the necessary corrections made at an additional cost to the owner.

Acceptable Soil Test Results:

	Landscape Trees & Shrubs	Turf
pH Range	5.0-7.0	6.0-7.0
Organic Matter	>1.5%	>2.5%
Magnesium (Mg)	100-lbs./acre	100-lbs./acre
Phosphorus (P2O5)	150-lbs./acre	150-lbs./acre
Potassium (K2O)	120-lbs./acre	120-lbs./acre
Soluble salts	Not to exceed 900ppm/1.9 mmhos/cm in soil; not to exceed 1400 ppm/2.5 mmhos/cm in high organic mix	Not to exceed 750ppm/0.75 mmhos/cm in soil; not to exceed 2000 ppm/2.0 mmhos/cm in high organic mix

For unusual soil conditions, the following optional tests are recommended with levels not to exceed:

Boron	3 pounds per acre
Manganese	50 pounds per acre
Potassium (K2O)	450 pounds per acre
Sodium	20 pounds per acre

#### WORKMANSHIP

During landscape maintenance operations, all areas shall be kept neat and clean. Precautions shall be taken to avoid damage to existing structures. All work shall be performed in a safe manner to the operators, the occupants and any pedestrians.

Upon completion of maintenance operations, all debris and waste material shall be cleaned up and removed from the site, unless provisions have been granted by the owner to use on-site trash receptacles.

Any damage to the landscape, the structure, or the irrigation system caused by the maintenance contractor, shall be repaired by the maintenance contractor without charge to the owner.

### TURF

#### GENERAL CLEAN UP

Prior to mowing, all trash, sticks, and other unwanted debris shall be removed from lawns, plant beds, and paved areas.

#### MOWING

Turf grasses, including blue grass, tall fescue, perennial ryegrass, etc., shall be maintained at a height of 2" to 3" in spring and fall. From June through September, mowing height shall be maintained at no less than 3".

The mowing operation includes trimming around all obstacles, raking excessive grass clippings and removing debris from walks, curbs, and parking areas. Caution: Mechanical weeders should NOT be used around trees because of potential damage to the bark.

#### EDGING

Edging of all sidewalks, curbs and other paved areas shall be performed once every other mowing. Debris from the edging operations shall be removed and the areas swept clean. Caution shall be used to avoid flying debris.

#### FERTILIZING

Seasonally stepped fertilizer shall be applied in areas based on the existing turf species.

#### LAWN WEED CONTROL: HERBICIDES

Selection and proper use of herbicides shall be the landscape contractor's responsibility. All chemical applications shall be performed under the supervision of a Licensed Certified Applicator. Read the label prior to applying any chemical.

#### INSECT & DISEASE CONTROL FOR TURF

The contractor shall be responsible for monitoring the site conditions on each visit to determine if any insect pest or disease problems exist. The contractor shall identify the insect pest or disease, as well as the host plant, and then consult the most current edition of the Cooperative Extension Service's "Commercial Insecticide Recommendation for Turf" for control. The licensed applicator shall be familiar with the label provided for the selected product prior to application.

Inspection and treatment to control insect pests shall be included in the contract price.

### TREES, SHRUBS, & GROUND COVER

#### PRUNING

All ornamental trees, shrubs and ground cover shall be pruned when appropriate to remove dead or damaged branches, develop the natural shapes. Do not shear trees or shrubs. If previous maintenance practice has been to shear and ball, then a natural shape will be restored gradually.

Pruning Guidelines:

- Prune plants that flower before the end of June (spring blooming) immediately after flowering. Flower buds develop during the previous growing season. Fall, winter or spring pruning would reduce the spring flowering display.
- Prune plants that flower in July - September (summer or autumn blooming) in winter or spring before new growth begins, since these plants develop flowers on new growth.
- Delay pruning plants grown for ornamental fruits, such as Cotonasters and Viburnums.
- Hollies and other evergreens may be pruned during winter in order to use their branches for seasonal decoration. However, severe pruning of evergreens should be done in early spring only.
- Broadleaf evergreen shrubs shall be hand-pruned to maintain their natural appearance after the new growth hardens off.
- Hedges or shrubs that require shearing to maintain a formal appearance shall be pruned as required. Dead wood shall be removed from sheared plants before the first shearing of the season.
- Conifers shall be pruned, if required, according to their genus.
  - Yews, Junipers, Hemlocks and Arborvitae may be pruned after new growth has hardened off in late summer.
  - Firs and spruces may be lightly pruned in late summer, fall, or winter after completing growth. Leave side buds. Never cut central leader.
  - Pines may be lightly pruned in early June by reducing candles.
- Groundcover shall be edged and pruned as needed to contain it within its borders.
- Thinning: Remove branches and water sprouts by cutting them back to their point of origin on parent stems. This method results in a more open plant, without stimulating excessive growth. Thinning is used on Crab Apples, Lilacs, Viburnums, etc.
- Renewal pruning: Remove oldest branches of shrub at ground, leaving the younger, more vigorous branches. Also remove weak stems. On overgrown plants, this method may be best done over a three-year period. Renewal pruning may be used on Forsythia, Hydrangea, Spiraea, etc.

Plants overhanging passageways and parking areas and damaged plants shall be pruned as needed.

Shade trees that cannot be adequately pruned from the ground shall not be included in the Maintenance Contract. A certified arborist under a separate contract shall perform this type of work.

#### SPRING CLEANUP

Plant beds shall receive a general cleanup before fertilizing and mulching. Cleanup includes removing debris and trash from beds and cutting back herbaceous perennials left standing through winter, e.g. ornamental grasses, Sedum Autumn Joy.

#### FERTILIZING

For trees, the rate of fertilization depends on the tree species, tree vigor, area available for fertilization, and growth stage of the tree. Mature specimens benefit from fertilization every 3 to 4 years; younger trees shall be fertilized more often during rapid growth stages.

The current recommendation is based on the rate of 1000 square feet of area under the tree to be fertilized. For deciduous trees, 2 to 6 pounds of Nitrogen per 1000 square feet; for narrow-leaf evergreens, 1 to 4 pounds of Nitrogen per 1000 square feet; for broadleaf evergreens, 1 to 3 pounds of Nitrogen per 1000 square feet.

Shrubs and groundcover shall be top-dressed with compost 1" deep or fertilized once in March with 10-6-4 analysis fertilizer at the rate of 3 pounds per 100 square feet of bed area. Ericaceous material shall be fertilized with an ericaceous fertilizer at the manufacturer's recommendation rate. If plants are growing poorly, a soil sample should be taken.

### TREES, SHRUBS, & GROUND COVER (CONT.)

#### MULCHING

Annually, all tree and shrub beds will be prepared and mulched, to a minimum depth of 3" with quality mulch to match existing. Bed preparation shall include removing all weeds, cleaning up said bed, edging and cultivating decayed mulch into the soil. Debris from edging is to be removed from beds where applicable. If deemed necessary, a pre-emergent herbicide may be applied to the soil to inhibit the growth of future weeds.

Organically maintained gardens shall not receive any pre-emergent herbicides. Mulch in excess of 4" will be removed from the bed areas. SPECIAL CARE shall be taken in the mulching operation not to over-mulch or cover the base of trees and shrubs. This can be detrimental to the health of the plants.

#### WEEDING

All beds shall be weeded on a continuous basis throughout the growing season to maintain a neat appearance at all times.

Pre-emergent (soil-applied) and post-emergent (foliar-applied) herbicides shall be used where and when applicable and in accordance with the product's label.

#### INSECT & DISEASE CONTROL: TREES, SHRUBS & GROUNDCOVER

The maintenance contractor shall be responsible for monitoring the landscape site on a regular basis. The monitoring frequency shall be monthly except for growing season, which will be every other week. Trained personnel shall monitor for plant damaging insect activity, plant pathogenic diseases and potential cultural problems in the landscape. The pest or cultural problem will be identified under the supervision of the contractor.

For plant damaging insects and mites identified in the landscape, the contractor shall consult and follow the recommendations of the most current edition of the state Cooperative Service publication on insect control on landscape plant material.

Plant pathogenic disease problems identified by the contractor that can be resolved by pruning or physical removal of damaged plant parts will be performed as part of the contract. For an additional charge, plant pathogenic diseases that can be resolved through properly timed applications of fungicides shall be made when the owner authorizes it.

If the contractor notes an especially insect-or-disease-prone plant species in the landscape, he/she will suggest replacement with a more pest-resistant cultivar or species that is consistent with the intent of the landscape design.

NOTE: For identification of plant-damaging insects and mites, a reference textbook that can be used is Insects that feed on Trees and Shrubs by Johnson and Lyon, Comstock Publishing Associates. For plant pathogenic diseases, two references are suggested: Scouting and Controlling Woody Ornamental Diseases in Landscapes and Nurseries, authorized by Gary Moorman, published by Penn State College of Agricultural Sciences, and Diseases of Trees and Shrubs by Sinclair and Lyon, published by Comstock Publishing Press.

#### TRASH REMOVAL

The maintenance contractor shall remove trash from all shrub and groundcover beds with each visit.

#### LEAF REMOVAL

All fallen leaves shall be removed from the site in November and once in December. If requested by the owner, the maintenance contractor, at an additional cost to the owner shall perform supplemental leaf removals.

#### WINTER CLEAN-UP

The project shall receive a general clean-up once during each of the winter months, i.e., January, February, and March.

Clean-up includes:

- Cleaning curbs and parking areas
- Removing all trash and unwanted debris
- Turning mulch where necessary
- Inspection of grounds

### SEASONAL COLOR: PERENNIALS, ANNUALS, AND BULBS

The installation of perennials, annuals, and bulbs, unless specified herein, shall be reviewed with the owner, and, if accepted, installed and billed to the owner.

#### SEASONAL COLOR MAINTENANCE

Perennialization of Bulbs:

- After flowering, cut off spent flower heads.
- Allow leaves of daffodils and hyacinths to remain for six weeks after flowers have faded. Cut off at base.
- Allow leaves of other bulbs to yellow naturally and then cut off at base.
- Apply fertilizer after flowering in spring, possibly again in fall. Apply 10-10-10 at the rate of 2 pounds per 1000 square feet or top-dress with compost 1" deep. Fall fertilization with a bulb fertilizer or mulching with 1" of compost is optional.

Flower Rotation:

- Bulbs: Remove the entire plant and bulb after flowers have faded or at the direction of the owner and install new plants if included in contract.
- Summer Annuals or Fall Plants:
  - Dead heading: Pinch and remove dead flowers on annuals as necessary.
  - Fertilizing Summer Annuals: Fertilize using one or two methods: Apply a slow-release fertilizer in May following manufacturer's recommendations. A booster such as 10-10-10 may be necessary in late summer. Or, apply liquid fertilizations of 20-20-20 water-soluble fertilizers, not to exceed 2 pounds of 20-20-20 per 100 gallons of water, monthly; or mulch with compost 1" deep.
  - Removal: If fall plants are to be installed, summer annuals shall be left in the ground until the first killing frost and then removed, unless otherwise directed by the owner.

#### Perennials:

- After initial installation, if a time-released fertilizer has been incorporated during plant installation, no more fertilizer need be applied the first growing season.
- The following year:
  - Fertilize perennials with a slow-release fertilizer or any 50% organic fertilizer, or mulch perennials with compost 1" deep.
  - Cut all deciduous perennials flush to the ground by March 1, if this was not done the previous fall, to allow new growth to develop freely.
  - Mulch the perennial bed once in early spring at 1"-2" depth. If soil is bared in late fall, re-mulch lightly after ground is frozen to protect perennials.
  - Inspect for insect or disease problems on perennials. Monitor and control slugs on hostas and ligularias. Powdery mildew on phlox, monardas, and asters can be prevented with properly timed fungicides or use of disease-resistant varieties.
  - Weed perennial bed as specified in "WEEDING" above.
  - Prune branching species to increase density. Cut only the flowering stems after blooming. Do not remove the foliage.
- The following fall cut back deteriorating plant parts unless instructed to retain for winter interest, e.g. Sedum Autumn Joy and ornamental grasses.
- Long-term Care:
  - Divide plants that overcrowd the space provided. Divide according to the species. Some need frequent dividing, e.g. asters and yarrow every two years; other rarely, if ever, e.g. peonies, hostas, and astilbe.
  - For detailed information regarding the care of specific perennials, refer to All About Perennials by Ortho; Perennials: How to Select, Grow and Enjoy by Pamela Harper and Frederick McGouty, Hp Books Publisher; Herbaceous Perennial Plants: A Treatise on their Identification, Culture and Garden Attributes by Allan Arnitage, Stipes Pub LLC.

### SUMMARY OF MAINTENANCE

#### LAWN MAINTENANCE

- Soil analysis performed annually to determine pH. If pH does not fall within specified range, adjust according to soil test recommendations.
- Maintain proper fertility and pH levels of the soil to provide an environment conducive to turf vitality for turf grasses.
- Mow turf on a regular basis and as season and weather dictates. Remove no more than the top 1/3 of leaf blade. Clippings on paved and bed areas will be removed.
- Aerate warm season turf areas to maintain high standards of turf appearance.
- Apply pre-emergent to turf in two applications in early February and early April to extend barrier.
- Apply post emergent as needed to control weeds.
- Mechanically edge curbs and walks.
- Apply non-selective herbicide, to mulched bed areas and pavement and remove excess runners to maintain clean defined beds.

#### TREE, GROUNDCOVER AND SHRUB BED MAINTENANCE

- Prune shrubs, trees and groundcover to encourage healthy growth and create a natural appearance.
- Mulch to be applied in February/March with a half rate in late summer to top dress.
- Apply pre-emergent herbicides in February and April.
- Manual weed control to maintain clean bed appearance.
- Apply fungicides and insecticides as needed to control insects and disease.
- Ornamental shrubs, trees and groundcovers to be fertilized three (3) times per year with a balanced material (January/February, April/May, and October/November)
- Edge all mulched beds.
- Remove all litter and debris.

#### GENERAL MAINTENANCE

- Remove all man-made debris, blow edges.
- Inspect grounds on a monthly basis and schedule inspection with Unit Operator.

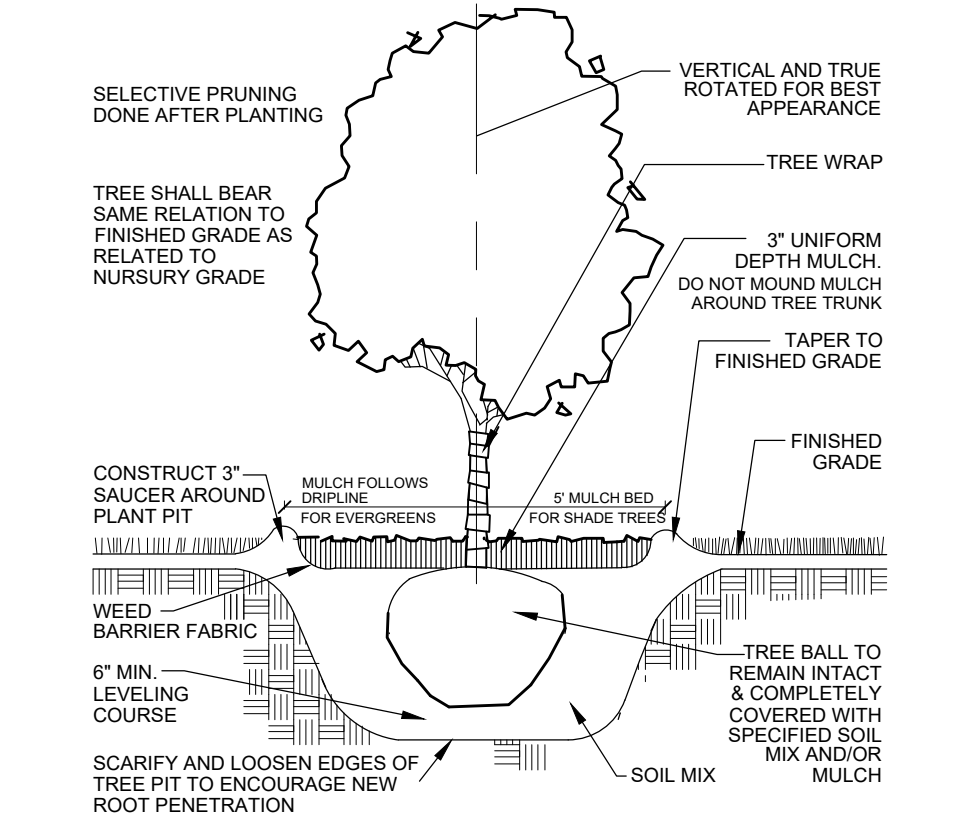

1 TREE PLANTING DETAIL  
L2.1 SCALE: NO SCALE

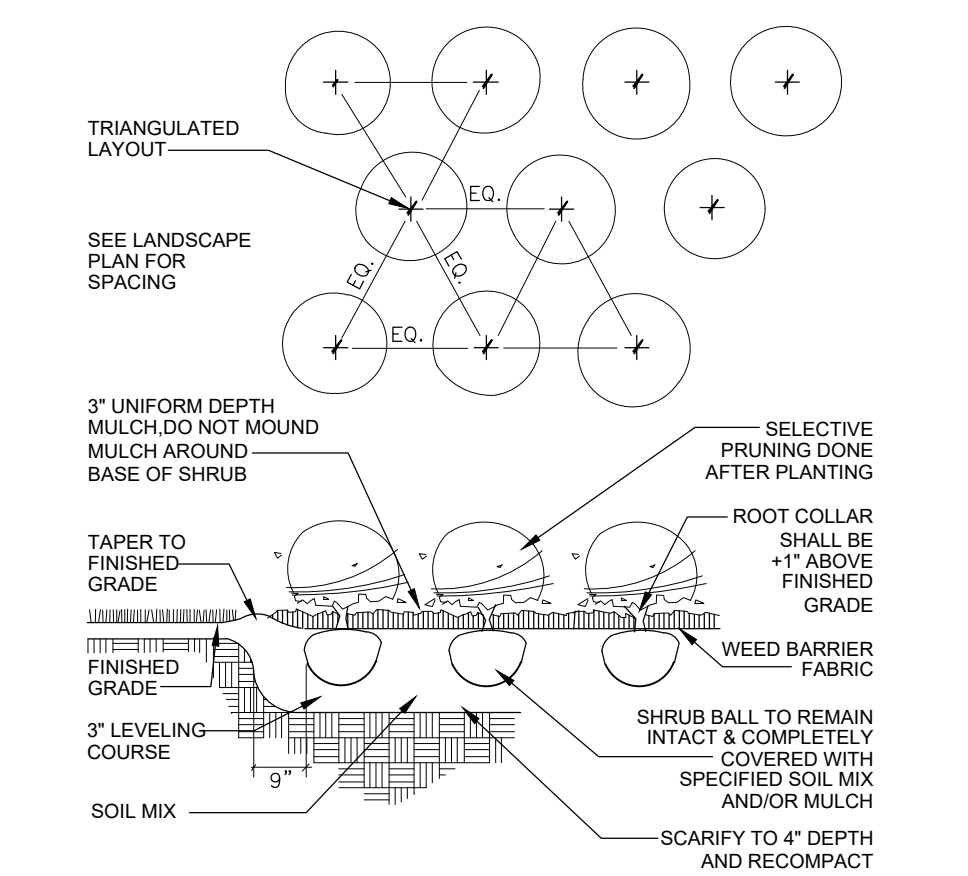

2 SHRUB PLANTING DETAIL  
L2.1 SCALE: NO SCALE

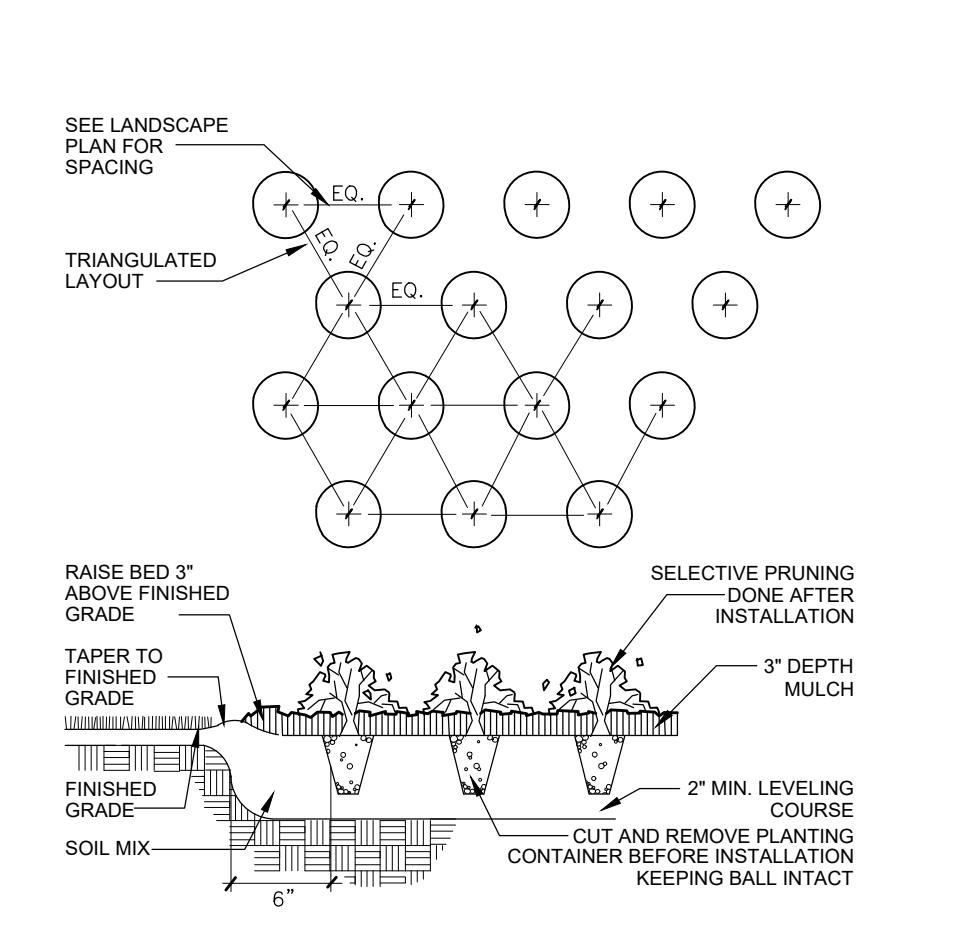

3 GROUNDCOVER DETAIL  
L2.1 SCALE: NO SCALE

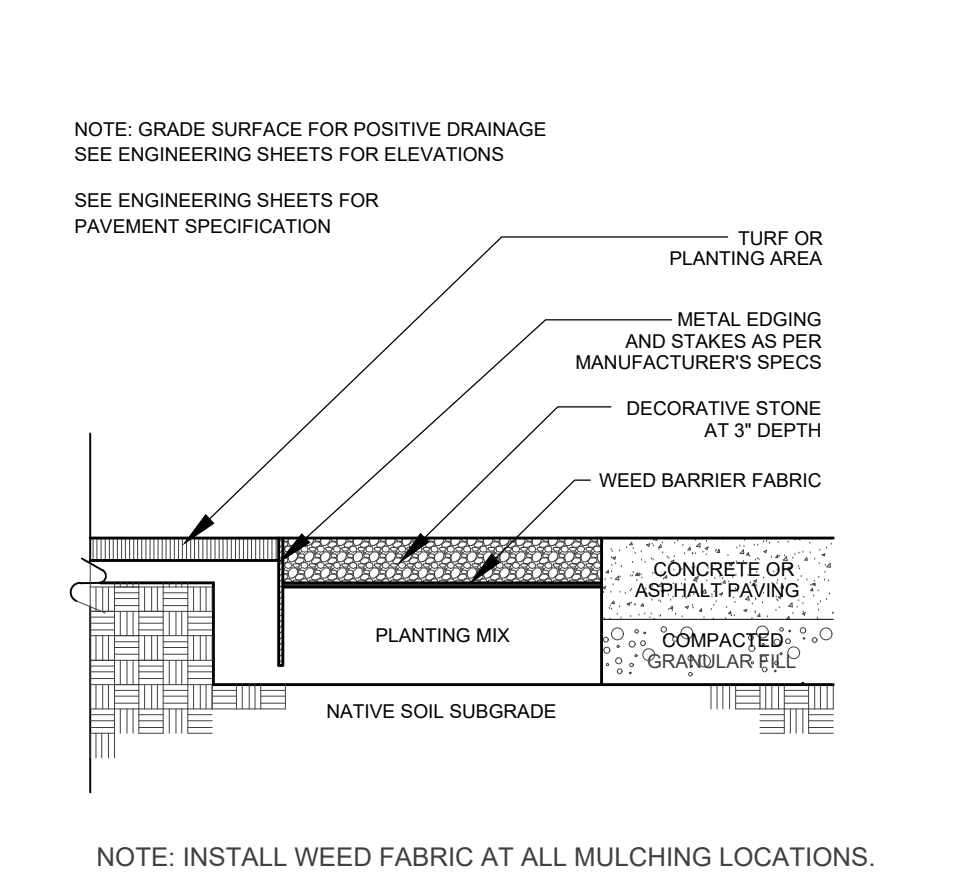

4 ROCK MULCH DETAIL  
L2.1 SCALE:

**Kathryn Talty**  
landscape architecture

Winnetka, Illinois 60093  
847.612.5154  
www.kraltalydesign.com

no.	revision	description	initial	date
	ISSUED FOR REVIEW		KMT	01-30-23
	PER CITY COMMENTS		KMT	03-06-23
	PER CITY COMMENTS		KMT	03-28-23

**PANDA EXPRESS**  
LOCKPORT, IL

**WEED BARRIER STANDARD MAINTENANCE SPECIFICATIONS PLANTING NOTES CONSTRUCTION DETAILS**

date	checked
01-10-23	KMT
drawn	
KMT	
job no.	
23020	
sheet no.	
L 2.1	



### GENERAL NOTES

- REFERENCED CODES
  - ALL PAVEMENT AND STORM SEWER CONSTRUCTION SHALL CONFORM TO THE STANDARD SPECIFICATIONS FOR ROAD AND BRIDGE CONSTRUCTION (SSBCC), AND SUPPLEMENTAL SPECIFICATIONS AND RECURRING SPECIAL PROVISIONS, ADOPTED APRIL 1, 2016 BY ILLINOIS DEPARTMENT OF TRANSPORTATION AND ALL AMENDMENTS THERETO; AND IN ACCORDANCE WITH THE LATEST EDITION OF THE CODE OF THE MUNICIPALITY, EXCEPT AS MODIFIED HEREIN. IN CASE OF CONFLICT, MUNICIPAL CODE SHALL TAKE PRECEDENCE.
  - ALL SANITARY SEWER AND WATERMAIN CONSTRUCTION SHALL CONFORM TO THE STANDARD SPECIFICATIONS FOR WATER AND SEWER MAIN CONSTRUCTION IN ILLINOIS, PUBLISHED JANUARY 2014, AND IN ACCORDANCE WITH THE CODE OF THE MUNICIPALITY, EXCEPT AS MODIFIED HEREIN OR BY ANY PUBLIC AGENCY PERMITS ISSUED FOR THIS WORK. IN CASE OF CONFLICT, THE MORE RESTRICTIVE PROVISIONS SHALL APPLY.
  - ALL SIDEWALK AND PUBLIC AREAS MUST BE CONSTRUCTED IN ACCORDANCE WITH CURRENT ADA, ILLINOIS HANDICAP ACCESSIBILITY AND ANY APPLICABLE LOCAL ORDINANCES. WHEN CONFLICTS EXIST BETWEEN THE GOVERNING AGENCIES, THE MORE STRINGENT SHALL GOVERN.
  - THE CITED STANDARD SPECIFICATIONS, CODES AND PERMITS, WITH THESE CONSTRUCTION PLANS AND DETAILS, ARE ALL TO BE CONSIDERED PART OF THE CONTRACT. INCIDENTAL ITEMS ACCESSORIES NECESSARY TO COMPLETE THIS WORK MAY NOT BE SPECIFICALLY NOTED BUT ARE CONSIDERED A PART OF THIS CONTRACT.
- UTILITY LOCATIONS
  - THE UTILITY COMPANIES HAVE BEEN CONTACTED IN REFERENCE TO UTILITIES THEY OWN AND OPERATE WITHIN THE LIMITS FOR THIS PROJECT. DATA FROM THESE AGENCIES HAS BEEN INCORPORATED INTO THE PLANS. IT IS, HOWEVER, THE CONTRACTOR'S RESPONSIBILITY TO CONFIRM OR ESTABLISH THE EXISTENCE OF ALL UTILITY FACILITIES AND THEIR EXACT LOCATIONS, AND TO SAFELY SCHEDULE ALL UTILITY RELOCATIONS. FOR ADDITIONAL INFORMATION, THE AGENCIES LISTED ON THIS SHEET MAY BE CONTACTED.
  - THE CONTRACTOR SHALL BE RESPONSIBLE FOR HAVING THE UTILITY COMPANIES LOCATE THEIR FACILITIES IN THE FIELD PRIOR TO CONSTRUCTION AND SHALL ALSO BE RESPONSIBLE FOR THE MAINTENANCE AND PRESERVATION OF THESE FACILITIES. THE ENGINEER DOES NOT WARRANT THE LOCATION OF ANY EXISTING UTILITIES SHOWN ON THE PLAN. THE CONTRACTOR SHALL CALL J.U.I.E.L. AT 800-892-0123 AND THE MUNICIPALITY, FOR UTILITY LOCATIONS. THE CONTRACTOR SHALL NOTIFY ALL UTILITY COMPANIES AND THE MUNICIPALITY TWENTY-FOUR (24) HOURS PRIOR TO STARTING ANY CONSTRUCTION.
  - EASEMENTS FOR THE EXISTING UTILITIES, BOTH PUBLIC AND PRIVATE, AND UTILITIES WITHIN PUBLIC RIGHTS-OF-WAY ARE SHOWN ON THE PLANS ACCORDING TO AVAILABLE RECORDS. THE CONTRACTOR SHALL BE RESPONSIBLE FOR DETERMINING THE EXACT LOCATION IN THE FIELD OF THESE UTILITY LINES AND THEIR PROTECTION FROM DAMAGE DUE TO CONSTRUCTION OPERATIONS. IF EXISTING UTILITY LINES OR ANY MATERIALS ARE ENCOUNTERED WHICH CONFLICT WITH LOCATIONS OF THE NEW CONSTRUCTION, THE CONTRACTOR SHALL NOTIFY THE OWNER AND ENGINEER SO THAT THE CONFLICT MAY BE RESOLVED.
- UTILITY COORDINATION
  - OWNER SHALL OBTAIN EASEMENTS AND PERMITS NECESSARY TO FACILITATE CONSTRUCTION OF THE PROPOSED UTILITIES. THE CONTRACTOR, HOWEVER, SHALL FURNISH ALL REQUIRED BONDS AND EVIDENCE OF INSURANCE NECESSARY TO SECURE THESE PERMITS.
  - THE CONTRACTOR IS RESPONSIBLE FOR VERIFYING THE NATURE AND STATUS OF ALL UTILITY RELOCATION WORK PRIOR TO THE START OF CONSTRUCTION. THE CONTRACTOR SHALL TAKE APPROPRIATE MEASURES TO ENSURE THAT CONSTRUCTION OPERATIONS DO NOT INTERFERE WITH UTILITY FACILITIES AND RELOCATION WORK. THE SCHEDULE SHOULD REFLECT CONSTRUCTION SEQUENCING WHICH COORDINATES WITH ALL UTILITY RELOCATION WORK. THE CONTRACTOR SHALL BE REQUIRED TO ADJUST THE ORDER OF HIS WORK FROM TIME TO TIME, TO COORDINATE SAME WITH UTILITY RELOCATION WORK, AND SHALL PREPARE REVISED SCHEDULE(S) IN COMPLIANCE THEREWITH AS DIRECTED BY THE OWNER.
  - THE OWNER AND THE ENGINEER SHALL BE NOTIFIED IN WRITING BY THE CONTRACTOR AT LEAST 48 HOURS PRIOR TO THE START OF ANY OPERATION REQUIRING COOPERATION WITH OTHERS. AT & SHALL BE CONTACTED ONE MONTH PRIOR TO START OF CONSTRUCTION IN ITS UTILITY AREAS. ALL OTHER AGENCIES, UNLESS OTHERWISE NOTED, SHALL BE NOTIFIED IN WRITING BY THE CONTRACTOR TEN (10) DAYS PRIOR TO THE START OF ANY SUCH OPERATION.
- NO PLAN SHALL BE USED FOR CONSTRUCTION UNLESS SPECIFICALLY MARKED "FOR CONSTRUCTION". PRIOR TO COMMENCEMENT OF CONSTRUCTION THE CONTRACTOR SHALL VERIFY ALL DIMENSIONS AND CONDITIONS AFFECTING THE WORK WITH THE ACTUAL CONDITIONS AT THE JOB SITE. IN ADDITION, THE CONTRACTOR MUST VERIFY THE ENGINEER'S LINE AND GRADE STAKES. IF THERE ARE ANY DISCREPANCIES WITH WHAT IS SHOWN ON THE CONSTRUCTION PLANS, HE MUST IMMEDIATELY REPORT SAME TO THE ENGINEER BEFORE DOING ANY WORK. OTHERWISE THE CONTRACTOR ASSUMES FULL RESPONSIBILITY. IN THE EVENT OF DISAGREEMENT BETWEEN THE CONSTRUCTION PLANS, SPECIFICATIONS AND/OR SPECIAL DETAILS, THE CONTRACTOR SHALL SECURE WRITTEN INSTRUCTION FROM THE ENGINEER PRIOR TO PROCEEDING WITH ANY PART OF THE WORK AFFECTED BY OMISSIONS OR DISCREPANCIES. FAILING TO SECURE SUCH INSTRUCTION, THE CONTRACTOR WILL BE CONSIDERED TO HAVE PROCEEDED AT HIS OWN RISK AND EXPENSE. IN THE EVENT OF ANY DOUBT OR QUESTIONS ARISING WITH RESPECT TO THE TRUE MEANING OF THE CONSTRUCTION PLANS OR SPECIFICATIONS, THE DECISION OF THE ENGINEER SHALL BE FINAL AND CONCLUSIVE.
- ALL PROPOSED ELEVATIONS SHOWN ON THE PLANS ARE FINISHED SURFACE ELEVATIONS, UNLESS OTHERWISE SPECIFIED.
- UPON AWARDING OF THE CONTRACT, AND WHEN REQUIRED BY THE MUNICIPALITY OR OWNER, THE CONTRACTOR SHALL FURNISH A LABOR, MATERIAL AND PERFORMANCE BOND IN THE AMOUNT REQUIRED GUARANTEEING COMPLETION OF THE WORK. THE UNDERWRITER SHALL BE ACCEPTABLE TO THE MUNICIPALITY OR OWNER, AS APPROPRIATE.
- THE CONTRACTORS SHALL PLAN THEIR WORK BASED ON THEIR OWN BORINGS, EXPLORATIONS AND OBSERVATIONS TO DETERMINE SOIL CONDITIONS AT THE LOCATION OF THE PROPOSED WORK. HOWEVER, IF THE OWNER HAS A SOILS REPORT, THE RESULTS WILL BE AVAILABLE FROM THE OWNER UPON WRITTEN REQUEST.
- CONTRACTOR SHALL VIDEO TAPE WORK AREA PRIOR TO CONSTRUCTION FOR THE PURPOSE OF DOCUMENTING EXISTING CONDITIONS.
- COMMENCING CONSTRUCTION
  - THE CONTRACTOR SHALL NOTIFY THE OWNER AND/OR HIS REPRESENTATIVE AND THE AFFECTED GOVERNMENTAL AGENCIES IN WRITING AT LEAST 14 WORKING DAYS PRIOR TO COMMENCEMENT OF CONSTRUCTION. IN ADDITION, THE CONTRACTOR SHALL NOTIFY AS NECESSARY, ALL TESTING AGENCIES, EITHER MUNICIPALITY'S OR THE OWNER'S, SUFFICIENTLY IN ADVANCE OF CONSTRUCTION. ALL MATERIAL TESTING SHALL BE THE RESPONSIBILITY AND EXPENSE OF THE CONTRACTOR. THE TESTING AGENCY SHALL MEET THE APPROVAL OF THE OWNER.
  - FAILURE OF CONTRACTOR TO ALLOW PROPER NOTIFICATION TIME WHICH RESULTS IN TESTING COMPANIES TO BE UNABLE TO VISIT SITE AND PERFORM TESTING WILL CAUSE CONTRACTOR TO SUSPEND OPERATION (PERTAINING TO TESTING) UNTIL TESTING AGENCY CAN SCHEDULE TESTING OPERATIONS. COST OF SUSPENSION OF WORK TO BE BORNE BY CONTRACTOR.
- ALL CONTRACTORS SHALL KEEP ACCESS AVAILABLE AT ALL TIMES FOR ALL TYPES OF TRAFFIC. AT NO TIME SHALL ACCESS BE DENIED TO ADJACENT PROPERTIES.
- THE CONTRACTOR SHALL PRESERVE ALL CONSTRUCTION STAKES UNTIL THEY ARE NO LONGER NEEDED, ANY STAKES DESTROYED OR DISTURBED BY THE CONTRACTOR PRIOR TO THEIR USE SHALL BE RESET BY THE DEVELOPER'S ENGINEER AT CONTRACTOR'S COST.
- ANY EXISTING SIGNS, LIGHT STANDARDS AND UTILITY POLES WHICH INTERFERE WITH CONSTRUCTION OPERATIONS AND NOT NOTED FOR DISPOSAL, SHALL BE REMOVED AND RESET BY THE CONTRACTOR AT HIS OWN EXPENSE AS SHOWN ON THE ENGINEERING PLANS OR AS DIRECTED BY THE DEVELOPER. ANY DAMAGE TO THESE ITEMS SHALL BE REPAIRED OR REPLACED BY THE CONTRACTOR AT HIS OWN EXPENSE TO THE SATISFACTION OF THE OWNER. ANY SIGN NOT REQUIRED TO BE RESET, SHALL BE DELIVERED TO THE RESPECTIVE OWNERS.
- REMOVAL OF SPECIFIED ITEMS, INCLUDING BUT NOT LIMITED TO, PAVEMENT, SIDEWALK, CURB, CURB AND GUTTER, CULVERTS, ETC. SHALL BE DISPOSED OF OFF-SITE BY THE CONTRACTOR AT HIS OWN EXPENSE. HE IS RESPONSIBLE FOR ANY PERMIT REQUIRED FOR SUCH DISPOSAL.
- ALL FIELD TILE ENCOUNTERED DURING CONSTRUCTION OPERATIONS SHALL BE CONNECTED TO THE PROPOSED STORM SEWER SYSTEM OR SHALL BE RESTORED TO PROPER OPERATING CONDITION. A RECORD OF THE LOCATION OF ALL FIELD TILE OR DRAIN PIPE ENCOUNTERED SHALL BE KEPT BY THE CONTRACTOR AND TURNED OVER TO THE ENGINEER, DEVELOPER OR MUNICIPAL ENGINEER UPON COMPLETION OF THE PROJECT. THE COST OF THIS WORK SHALL BE CONSIDERED AS INCIDENTAL TO THE CONTRACT AND NO ADDITIONAL COMPENSATION WILL BE ALLOWED.
- THE CONTRACTOR IS SOLELY RESPONSIBLE FOR SAFETY ON THE JOB.
- THE CONTRACTOR SHALL COLLECT AND REMOVE ALL CONSTRUCTION DEBRIS, EXCESS MATERIALS, TRASH, OIL AND GREASE RESIDUE, MACHINERY, TOOLS AND OTHER MISCELLANEOUS ITEMS WHICH WERE NOT PRESENT PRIOR TO PROJECT COMMENCEMENT AT NO ADDITIONAL EXPENSE TO THE OWNER. THE CONTRACTOR SHALL BE RESPONSIBLE FOR ACQUIRING ANY AND ALL PERMITS NECESSARY FOR THE HAULING AND DISPOSAL, REQUIRED FOR CLEAN-UP AS DIRECTED BY THE ENGINEER OR OWNER. BURNING ON THE SITE IS NOT PERMITTED.
- ALL EXISTING UTILITIES OR IMPROVEMENTS, INCLUDING WALKS, CURBS, PAVEMENT AND PARKWAYS DAMAGED OR REMOVED DURING CONSTRUCTION SHALL BE PROMPTLY RESTORED TO THEIR RESPECTIVE ORIGINAL CONDITION. THIS WORK SHALL BE CONSIDERED INCIDENTAL TO THE CONTRACT UNLESS SPECIFICALLY NOTED ON THE PLANS.
- TREES NOT MARKED FOR REMOVAL SHALL BE CONSIDERED AS DESIGNATED TO BE SAVED AND SHALL BE PROTECTED UNDER THE PROVISIONS OF (SSBCC) ARTICLE 201.05.
- LIMB PRUNING SHALL BE PERFORMED UNDER THE SUPERVISION OF THE LANDSCAPE ARCHITECT MEETING THE OWNER'S APPROVAL AND SHALL BE UNDERTAKEN IN A TIMELY FASHION SO AS NOT TO INTERFERE WITH CONSTRUCTION.
- ALL LIMBS, BRANCHES, AND OTHER DEBRIS RESULTING FROM THIS WORK SHALL BE DISPOSED OF OFF-SITE BY THE CONTRACTOR AT HIS OWN EXPENSE OFF-SITE.
- ALL CUTS OVER 1" IN DIAMETER SHALL BE MADE FLUSH WITH THE NEXT LARGE BRANCH. WOUNDS OVER 1" IN DIAMETER SHALL BE PAINTED WITH AN APPROVED TREE PAINT.

- GENERAL EXCAVATION/UNDERGROUND NOTES
  - SLOPE SIDES OF EXCAVATIONS TO COMPLY WITH CODES AND ORDINANCES HAVING JURISDICTION. SHORE AND BRACE WHERE SLOPING IS NOT POSSIBLE EITHER BECAUSE OF SPACE RESTRICTIONS OR STABILITY OF MATERIAL EXCAVATED. MAINTAIN SIDES AND SLOPES OF EXCAVATIONS IN A SAFE CONDITION UNTIL COMPLETION OF BACKFILLING.
  - PROVIDE MATERIALS FOR SHORING AND BRACING, SUCH AS SHEET PILING, UPRIGHTS, STRINGERS AND CROSS BRACES, IN GOOD SERVICEABLE CONDITION. PROVIDE MINIMUM REQUIREMENTS FOR TRENCH SHORING AND BRACING TO COMPLY WITH CODES AND AUTHORITIES HAVING JURISDICTION. MAINTAIN SHORING AND BRACING IN EXCAVATIONS REGARDLESS OF TIME PERIOD EXCAVATIONS WILL BE OPEN. CARRY DOWN SHORING AND BRACING AS EXCAVATION PROGRESSES IN ACCORDANCE WITH OSHA AND GOVERNING AUTHORITY.
  - PREVENT SURFACE WATER AND SUBSURFACE OR GROUNDWATER FROM FLOWING INTO EXCAVATIONS. REMOVE WATER TO PREVENT SOFTENING OF FOUNDATION BOTTOMS, UNDERCUTTING FOOTINGS, AND SOIL CHANGES DETRIMENTAL TO STABILITY OF SUBGRADES AND FOUNDATIONS. PROVIDE AND MAINTAIN PUMPS, SUMPS, SUCTION AND DISCHARGE LINES AND OTHER DEWATERING SYSTEM COMPONENTS NECESSARY TO CONVEY WATER AWAY FROM EXCAVATIONS. CONVEY WATER REMOVED FROM EXCAVATIONS AND RAINWATER TO COLLECTING OR RUN-OFF AREAS ACCEPTABLE TO AUTHORITIES HAVING JURISDICTION. PROVIDE AND MAINTAIN TEMPORARY DRAINAGE DITCHES AND OTHER DIVERSIONS OUTSIDE EXCAVATION LIMITS FOR EACH STRUCTURE. DO NOT USE TRENCH EXCAVATIONS AS TEMPORARY DRAINAGE DITCHES.
  - IMMEDIATELY REPORT CONDITIONS THAT MAY CAUSE UNSOUND BEARING TO THE OWNER/DEVELOPER BEFORE CONTINUING WORK.
- FINAL ACCEPTANCE
  - ALL WORK PERFORMED UNDER THIS CONTRACT SHALL BE GUARANTEED BY THE CONTRACTOR AND HIS SURETY FOR A PERIOD OF TWELVE (12) MONTHS FROM THE DATE OF FINAL ACCEPTANCE OF THE PROJECT AND THE CONTRACTOR SHALL BE HELD RESPONSIBLE FOR ALL DEFECTS IN MATERIALS AND WORKMANSHIP OF WHATEVER NATURE DURING THAT PERIOD. THIS GUARANTEE SHALL BE PROVIDED IN THE FORM OF MAINTENANCE BOND IN THE AMOUNT OF 10% OF THE COST OF IMPROVEMENTS.
  - BEFORE ACCEPTANCE BY THE OWNER AND FINAL PAYMENT, ALL WORK SHALL BE INSPECTED BY THE OWNER OR HIS REPRESENTATIVE. FINAL PAYMENT WILL BE MADE AFTER ALL THE CONTRACTOR'S WORK HAS BEEN APPROVED AND ACCEPTED.
  - NO UNDERGROUND WORK SHALL BE COVERED UNTIL IT HAS BEEN APPROVED BY THE MUNICIPALITY. APPROVAL TO PROCEED MUST BE OBTAINED FROM THE MUNICIPALITY PRIOR TO INSTALLING PAVEMENT BASE, BINDER, SURFACE, AND PRIOR TO PLACING ANY CONCRETE AFTER FORMS HAVE BEEN SET.
  - AT THE CLOSE OF EACH WORKING DAY AND AT THE CONCLUSION OF CONSTRUCTION OPERATIONS, ALL DRAINAGE STRUCTURES AND FLOW LINES SHALL BE FREE FROM DIRT AND DEBRIS.
- UNDERGROUND NOTES
  - UNDERGROUND WORK SHALL INCLUDE TRENCHING, INSTALLATION OF PIPE, CASTINGS, STRUCTURES, BACKFILLING OF TRENCHES AND COMPACTION AND TESTING AS SHOWN ON THE CONSTRUCTION PLANS, FITTINGS AND ACCESSORIES NECESSARY TO COMPLETE THE WORK MAY NOT BE SPECIFIED, BUT SHALL BE CONSIDERED AS INCIDENTAL TO THE COST OF THE CONTRACT.
  - WHERE SHOWN ON THE PLANS OR DIRECTED BY THE ENGINEER, EXISTING DRAINAGE STRUCTURES AND SYSTEMS SHALL BE CLEANED OF DEBRIS AND PATCHED AS NECESSARY TO ASSURE INTEGRITY OF THE STRUCTURE. THIS WORK SHALL BE PAID FOR AT THE CONTRACT UNIT PRICE EACH FOR STRUCTURES AND CONTRACT UNIT PRICE PER LINEAL FOOT FOR SYSTEMS WHICH SHALL BE PAID IN FULL FOR CLEANING, PATCHING, REMOVAL AND DISPOSAL OF DEBRIS AND DIRT. DRAINAGE STRUCTURES AND SYSTEMS CONSTRUCTED AS PART OF THIS PROJECT SHALL BE MAINTAINED BY THE CONTRACTOR AT HIS EXPENSE. NO PAYMENT WILL BE MADE FOR CLEANING STRUCTURES OR SYSTEMS CONSTRUCTED AS PART OF THIS PROJECT.
  - ANY DEWATERING OF SEWER AND WATER TRENCHES AS WELL AS TEMPORARY SHEETING OR BRACING THAT MAY BE REQUIRED SHALL BE THE RESPONSIBILITY OF THE CONTRACTOR AND SHALL NOT BE CONSIDERED AS EXTRA WORK UNLESS THERE IS A SPECIFIC LINE ITEM FOR DEWATERING. IN THE EVENT THAT SOFT MATERIALS WITH UNCONFINED COMPRESSIVE STRENGTH LESS THAN 0.5 TSF ARE ENCOUNTERED IN SEWER CONSTRUCTION, THE CONTRACTOR SHALL, UPON APPROVAL OF THE OWNER AND/OR ENGINEER, OVER-EXCAVATE TO A DEPTH OF ONE (1) FOOT BELOW THE BOTTOM OF THE PIPE AND BACKFILL WITH COMPACTED CRUSHED STONE, PROPERLY FORMED TO FIT THE BOTTOM OF THE PIPE.
  - DO NOT CA-7 TRENCH BACKFILL IS REQUIRED WHEN ANY PORTION OF THE TRENCH IS WITHIN FIVE (5) FEET OF PROPOSED OR EXISTING PAVEMENT, SIDEWALK, CURB & GUTTER OR DRIVEWAYS.
  - THE CONTRACTOR SHALL INSTALL A 4" X 4" X 8" (NOMINAL) POST AT THE TERMINUS OF THE SANITARY, WATER AND STORM SERVICE, SANITARY AND STORM MANHOLES, CATCH BASINS, INLETS AND WATER VAULTS. THE POST SHALL EXTEND 4" ABOVE THE GROUND. THE TOP 12" OF SAID POST SHALL BE PAINTED AS FOLLOWS: SANITARY - RED, WATERMAIN - BLUE, STORM - GREEN.
  - AFTER THE STORM SEWER SYSTEM HAS BEEN CONSTRUCTED, THE CONTRACTOR SHALL PLACE EROSION CONTROL AT REAR YARD INLET LOCATIONS, AND AT OTHER LOCATIONS SELECTED BY THE ENGINEER, TO MINIMIZE THE AMOUNT OF SILTATION WHICH NORMALLY WOULD ENTER THE STORM SEWER SYSTEM.
  - HYDRANTS SHALL NOT BE FLUSHED DIRECTLY ON THE ROAD SUBGRADES. WHENEVER POSSIBLE, HOSES SHALL BE USED TO DIRECT THE WATER INTO LOT AREAS OR THE STORM SEWER SYSTEM (IF AVAILABLE). DAMAGE TO THE ROAD SUBGRADE OR LOT GRADING DUE TO EXCESSIVE WATER SATURATION AND/OR EROSION FROM HYDRANT FLUSHING, OR FROM LEAKS IN THE WATER DISTRIBUTION SYSTEM, WILL BE REPAIRED BY THE CONTRACTOR AT HIS COST.
  - ALL TOP OF FRAMES FOR STORM AND SANITARY SEWERS AND VALVE VAULT COVERS ARE TO BE ADJUSTED TO MEET FINAL FINISH GRADE. THIS ADJUSTMENT IS TO BE MADE BY THE SEWER AND WATER CONTRACTOR AND THE COST IS TO BE CONSIDERED INCIDENTAL. THESE ADJUSTMENTS TO FINISHED GRADE WILL NOT ALLEViate THE CONTRACTOR FROM ANY ADDITIONAL ADJUSTMENTS AS REQUIRED BY THE MUNICIPALITY UPON FINAL INSPECTION AND MAY VARY FROM PLAN GRADE.)
  - SLEEVES FOR UTILITY (COMED, TELEPHONE, ETC.) STREET CROSSING, SHALL BE INSTALLED WHERE DIRECTED BY THE OWNER. SLEEVES SHALL BE 6" PVC INSTALLED 36" BELOW THE TOP OF CURB AND EXTEND TWO FEET OUTSIDE THE CURB. TRENCH SHALL BE BACKFILLED WITH COMPACTED GRANULAR MATERIAL.
  - THE CONTRACTOR SHALL VERIFY THE SIZE AND INVERT ELEVATION OF ALL CONNECTIONS TO AVOID ANY CONFLICTS BEFORE STARTING WORK. NOTIFY OWNER OF ANY DISCREPANCIES.
- IT SHALL BE UNDERSTOOD THAT NEITHER THE MUNICIPALITY, ITS OFFICIALS, CONSULTANTS, NOR ITS EMPLOYEES ARE AGENTS OF OR REPRESENTATIVES OF THE OWNER, NONE-THE-LESS, THE MUNICIPALITY, ITS OFFICIALS AND EMPLOYEES ARE TO BE PROVIDED SAFE ACCESS TO ALL PHASES OF ALL WORK PERFORMED ON THE PROJECT SITE TO MONITOR THE QUALITY OF THE WORK AND ASSURE ITS CONFORMITY WITH THE PLANS AND SPECIFICATIONS. THERE SHALL BE NO PERSONAL LIABILITY UPON ANY OFFICIAL OR EMPLOYEE OF THE MUNICIPALITY ON ACCOUNT OF ACTIONS TAKEN OR NOT TAKEN IN THE COURSE OF THEIR WORK. THE CONTRACTOR MUST AT ALL TIMES MAINTAIN A SAFE ACCESS TO THE WORK FOR INSPECTORS, "SAFETY" MEANING CONDITIONS COMPLYING WITH ALL PROVISIONS OF ALL APPLICABLE AND RECOGNIZED SAFETY STANDARDS, FEDERAL, STATE AND LOCAL. IF ACCESS IS NOT SAFE AND INSPECTIONS CANNOT BE MADE UNDER SAFE CONDITIONS, THE INSPECTOR CAN ORDER CESSATION OF THE WORK SO AFFECTED UNTIL SUCH TIME AS CONTRACTOR PROVIDES SAFE ACCESS.

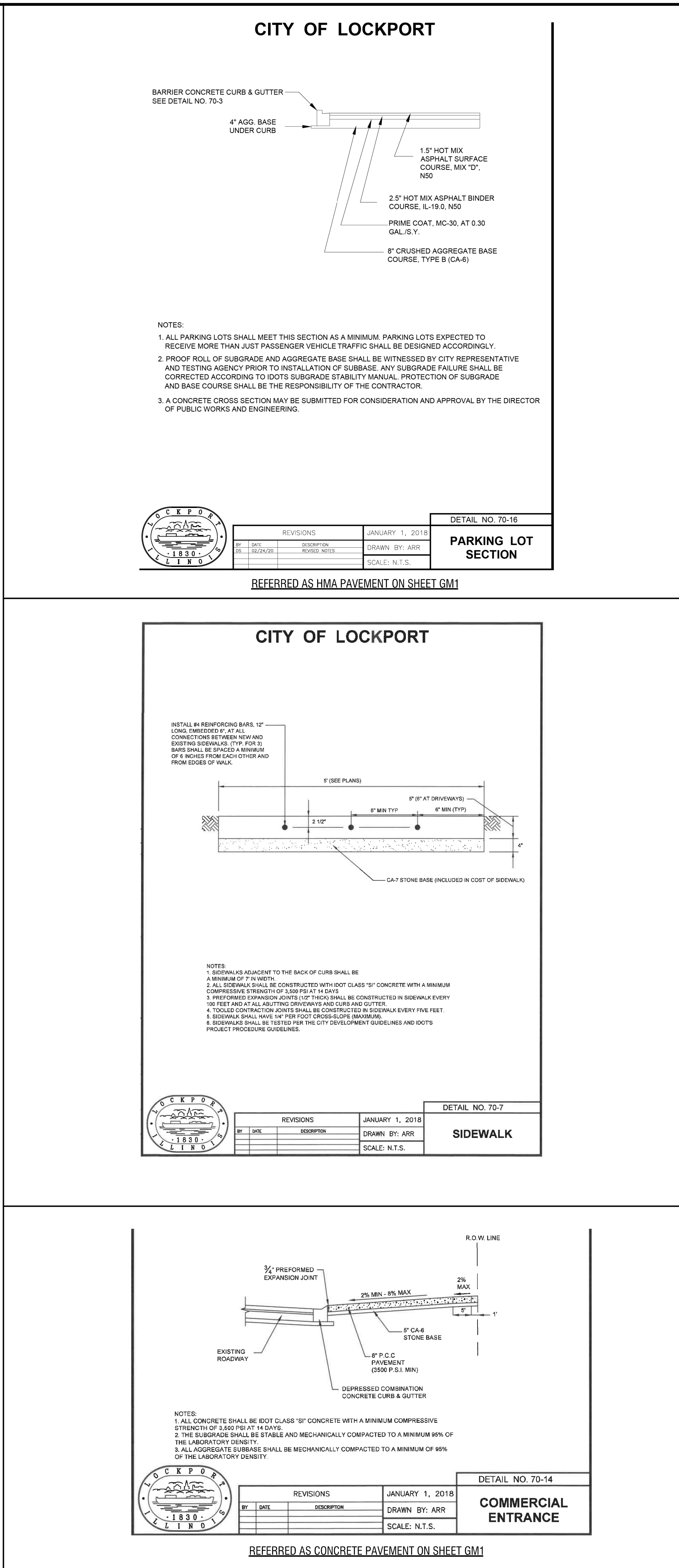

### LEGEND

EXISTING	DESCRIPTION	PROPOSED
	DRAIN TILE	
	STORM SEWER	
	SANITARY SEWER	
	SANITARY TRUNK SEWER	
	WATER MAIN (WITH SIZE)	
	PIPE TRENCH BACKFILL	
	GAS MAIN	
	TELEPHONE LINES	
	ELECTRIC LINE	
	FENCE	
	RIGHT-OF-WAY	
	EASEMENT	
	PROPERTY LINE	
	SETBACK LINE	
	CENTERLINE	
	CONTOUR	
	SANITARY MANHOLE	
	STORM MANHOLE	
	CATCH BASIN	
	INLET	
	FIRE HYDRANT	
	PRESSURE CONNECTION	
	PIPE REDUCER	
	VALVE AND VAULT VALVE	
	FLARED END SECTION	
	STREET LIGHT	
	UTILITY POLE	
	CONTROL POINT	
	SIGN	
	SPOT ELEVATION	
	SOIL BORING	
	OVERLAND FLOW ROUTE	
	DRAINAGE SLOPE	
	GUARDRAIL	
	WATER'S EDGE	
	CONCRETE	
	REVERSE PITCH CURB	
	TREE, FIR TREE, BUSH, & PROPOSED TREE TO REMOVE	

### ABBREVIATIONS

M = STORM MANHOLE	I = INVERT OR INLET	T/P = TOP OF PIPE
S = SANITARY MANHOLE	TF = TOP OF FOUNDATION	B/P = BOTTOM OF PIPE
CB = CATCH BASIN	GF = GARAGE FLOOR	WM = WATERMAIN
LP = LIGHT POLE	TC = TOP OF CURB	SAN = SANITARY SEWER
V = VALVE VAULT	TW = TOP OF DEPRESSED CURB	STM = STORM SEWER
E = END SECTION	TD = TOP OF RETAINING WALL	LO = LOOK OUT
FR = FIRE HYDRANT	BW = BOTTOM OF RETAINING WALL	PLO = PARTIAL LOOK OUT
GR = GRADE RING (HYDRANT)	OP = OUTLET OF PIPE	

### PERMITS

DESCRIPTION	LOG NO.	PERMIT NO.	DATE ISSUED
I EPA NPDES NOI	ILR10W764	ILR10W764	7/30/2013

### BENCHMARK

THE SOUTHWEST BOLT ON FIRE HYDRANT, LOCATED NORTH OF THE PROPOSED SITE APPROXIMATELY 160 FOOT WEST FROM THE CENTERLINE OF FARRELL ROAD AND APPROXIMATELY 56' FROM THE SOUTHEAST CORNER OF THE CULVERS NORTH OF THE PROPOSED SITE.

### CONTACT INFORMATION

<b>LOCKPORT PUBLIC WORKS DEPARTMENT</b> 7171 S. PINE BLVD LOCKPORT, IL 60441 (815) 838-6580 CONTACT PERSON: BRETT GANN	<b>CITY REVIEW ENGINEER CHAMIN &amp; ASSOCIATES</b> 221 W WASHINGTON ST MORRIS, IL 60450 (815) 942-1402 CONTACT PERSON: ROBERT SCHMUDE
--	--

NO.	DATE	REMARKS

  

NO.	DATE	REMARKS
1	3/6/23	PER CITY REVIEW
2	3/23/23	PER CITY REVIEW

**TYPICAL SECTIONS AND GENERAL NOTES**  
**ROSE CENTER LOCKPORT**  
**LOT 1A - PANDA EXPRESS**  
 LOCKPORT, ILLINOIS

**CONSULTING ENGINEERS**  
**SITE DEVELOPMENT ENGINEERS**  
**LAND SURVEYORS**  
 224 1/2 N. Liberty Street,  
 Morris, Illinois 60450  
 Phone: (815) 941-0260 Fax: (815) 941-0263

**SPACECO INC.**  
 FILENAME:  
 C2\_5225-03-GN1  
 DATE:  
 01/30/23  
 JOB NO.  
 5225-03-M  
 SHEET  
**GN1**  
 2 OF 11

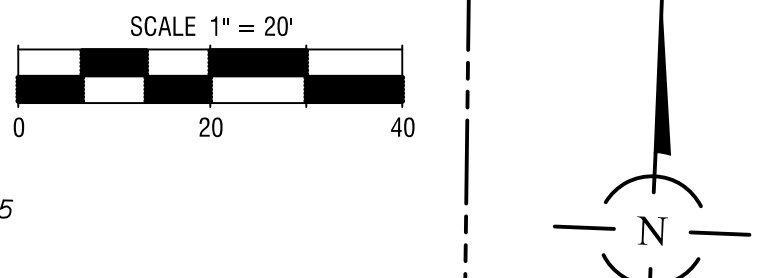
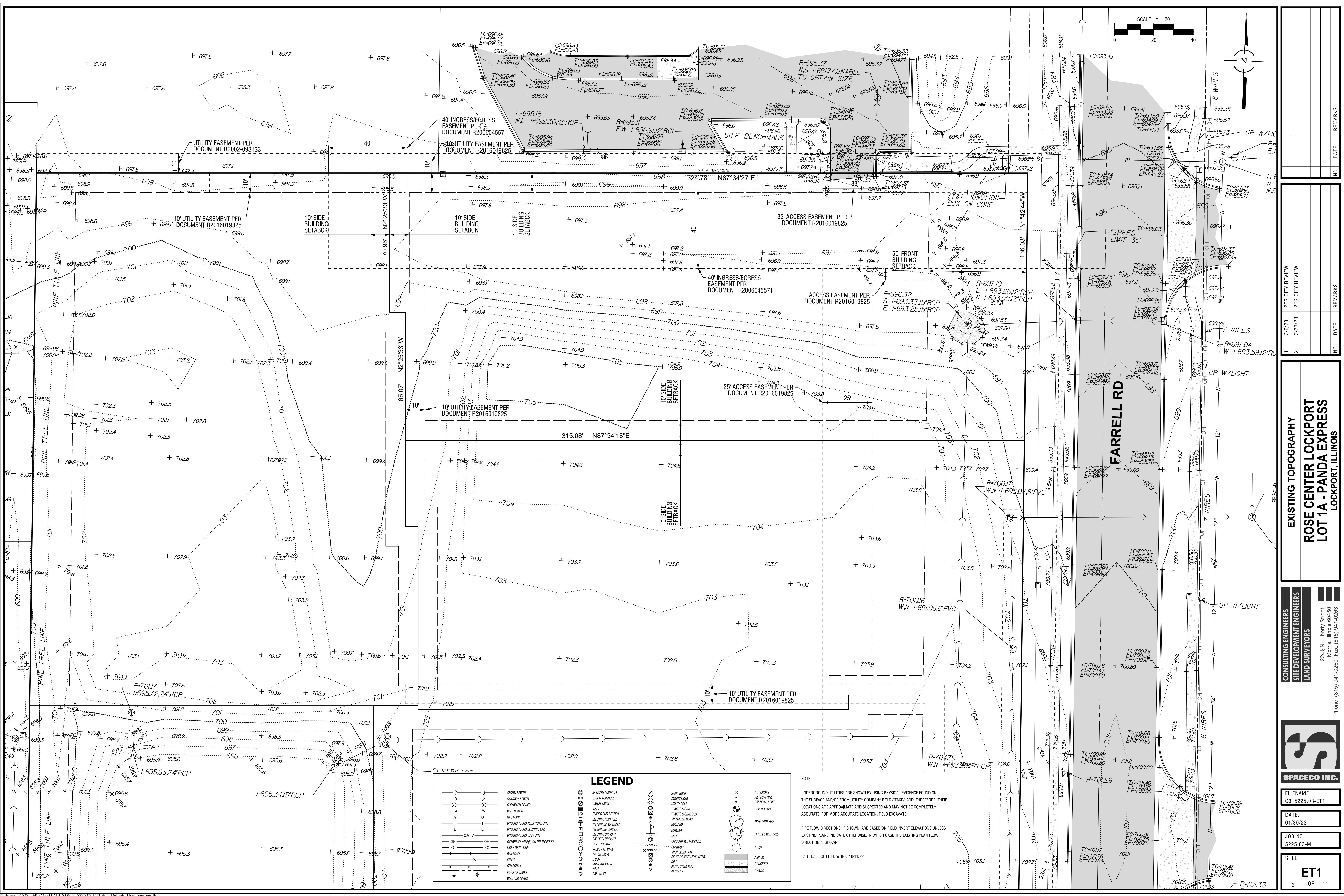

**LEGEND**

	STORM SEWER		SANITARY MANHOLE		HAND HOLE		CUT CROSS
	SANITARY SEWER		STORM MANHOLE		STREET LIGHT		PK/NOG NAIL
	COMBINED SEWER		CATCH BASIN		HANDHOLE SPIKE		SOIL BORING
	WATER MAIN		INLET		FLARED END SECTION		TREE WITH SIZE
	GAS MAIN		ELECTRIC MANHOLE		SPRINKLER HEAD		TREE WITH SIZE
	UNDERGROUND TELEPHONE LINE		TELEPHONE MANHOLE		BELLAND		BUSH
	UNDERGROUND ELECTRIC LINE		TELEPHONE UPRIGHT		MALLOCK		IRON/STEEL ROD
	CATV		ELECTRIC UPRIGHT		SIGN		IRON PIPE
	OVERHEAD WIRES ON UTILITY POLES		CABLE TV UPRIGHT		UNDERSIZED MANHOLE		
	FIBER OPTIC LINE		FIRE HYDRANT		COVER		
	RAILROAD		VALVE AND VAULT		SPOT ELEVATION		
	FENCE		WATER VALVE		RIGHT-OF-WAY MONUMENT		
	EDGE OF WATER		BOX		ASPHALT		
	WETLAND LIMITS		WELL		CONCRETE		
			AUXILIARY VALVE		GRAVEL		
			GAS VALVE				

**NOTE:**

UNDERGROUND UTILITIES ARE SHOWN BY USING PHYSICAL EVIDENCE FOUND ON THE SURFACE AND/OR FROM UTILITY COMPANY FIELD STAKES AND, THEREFORE, THEIR LOCATIONS ARE APPROXIMATE AND SUSPECTED AND MAY NOT BE COMPLETELY ACCURATE. FOR MORE ACCURATE LOCATION, FIELD EXCAVATE.

PIPE FLOW DIRECTIONS, IF SHOWN, ARE BASED ON FIELD INVERT ELEVATIONS UNLESS EXISTING PLANS INDICATE OTHERWISE, IN WHICH CASE THE EXISTING PLAN FLOW DIRECTION IS SHOWN.

LAST DATE OF FIELD WORK: 10/11/22

NO.	DATE	REMARKS
1	3/16/23	PER CITY REVIEW
2	3/23/23	PER CITY REVIEW

**EXISTING TOPOGRAPHY**  
**ROSE CENTER LOCKPORT**  
**LOT 1A - PANDA EXPRESS**  
 LOCKPORT, ILLINOIS

**CONSULTING ENGINEERS**  
**SITE DEVELOPMENT ENGINEERS**  
**LAND SURVEYORS**

224 N. Liberty Street,  
 Morris, Illinois 60450  
 Phone: (615) 941-0260 Fax: (615) 941-0263



FILENAME:	C3_5225-03-ET1
DATE:	01/30/23
JOB NO.	5225-03-M
SHEET	ET1
	3 OF 11

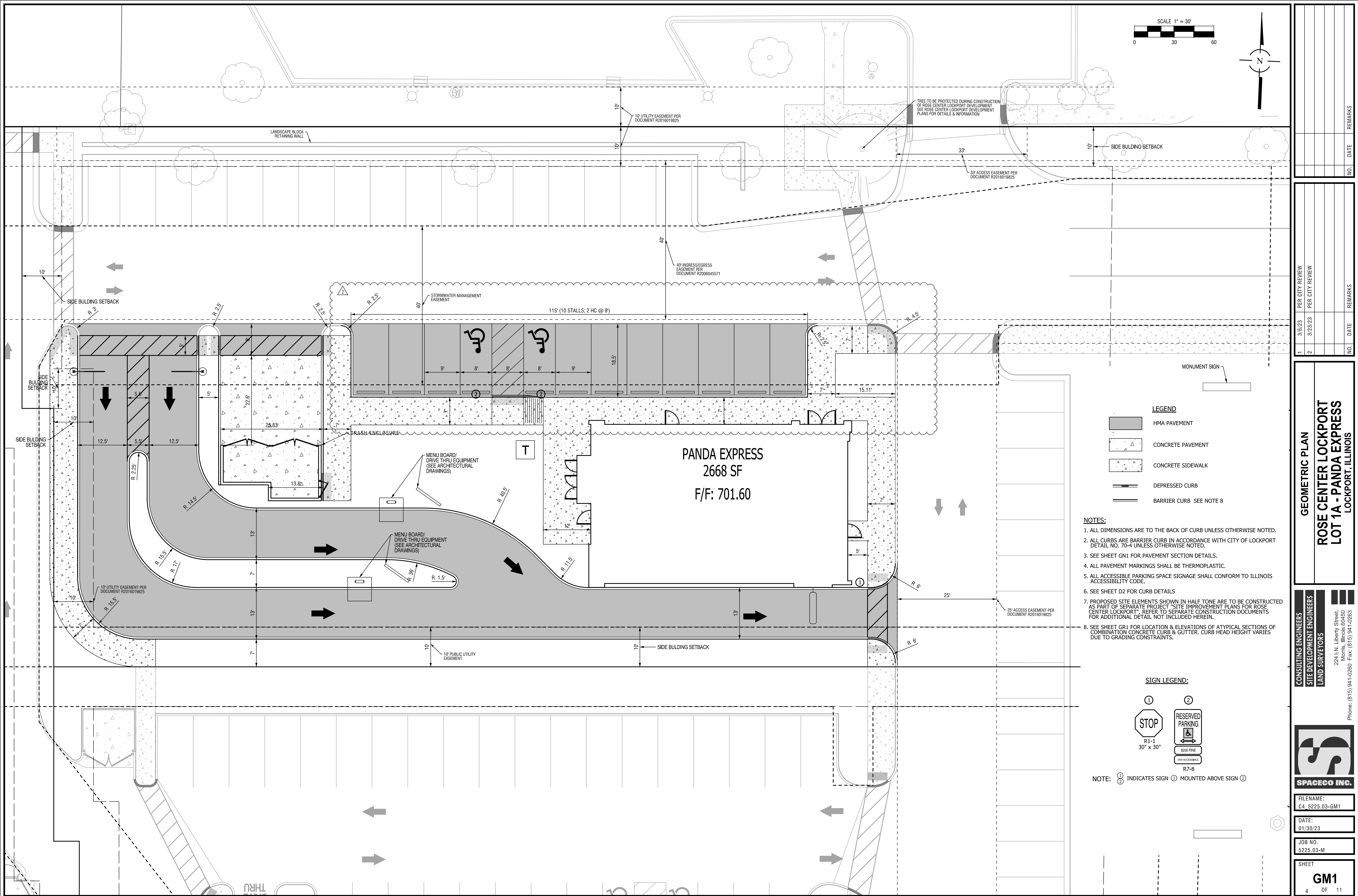

SCALE 1" = 30'

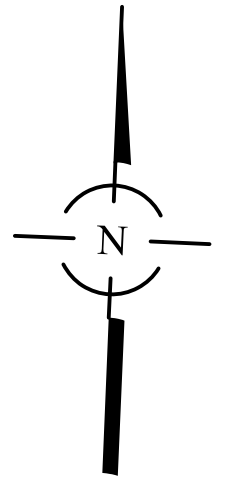

NO.	DATE	REMARKS
1	3/16/23	PER CITY REVIEW
2	3/23/23	PER CITY REVIEW

NO.	DATE	REMARKS
1	3/16/23	PER CITY REVIEW
2	3/23/23	PER CITY REVIEW

**GEOMETRIC PLAN**  
**ROSE CENTER LOCKPORT**  
**LOT 1A - PANDA EXPRESS**  
LOCKPORT, ILLINOIS

CONSULTING ENGINEERS  
SITE DEVELOPMENT ENGINEERS  
LAND SURVEYORS

224 1/2 N. Liberty Street,  
Morris, Illinois 60450  
Phone: (815) 941-0260 Fax: (815) 941-0263



FILENAME:  
C4\_5225.03-GM1

DATE:  
01/30/23

JOB NO.  
5225.03-M

SHEET  
**GM1**  
4 OF 11

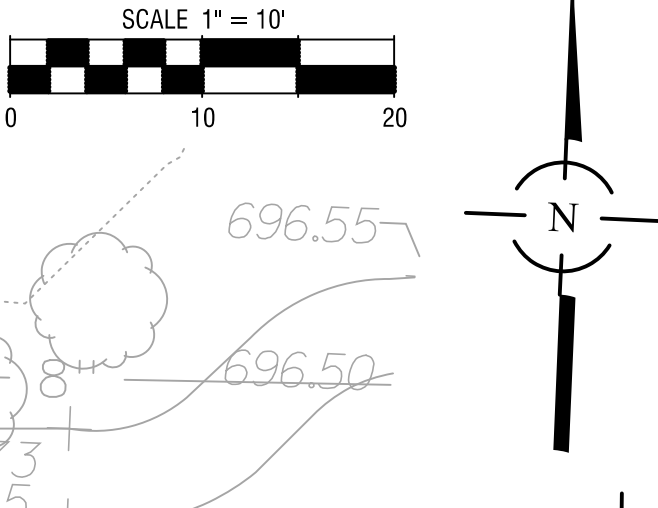
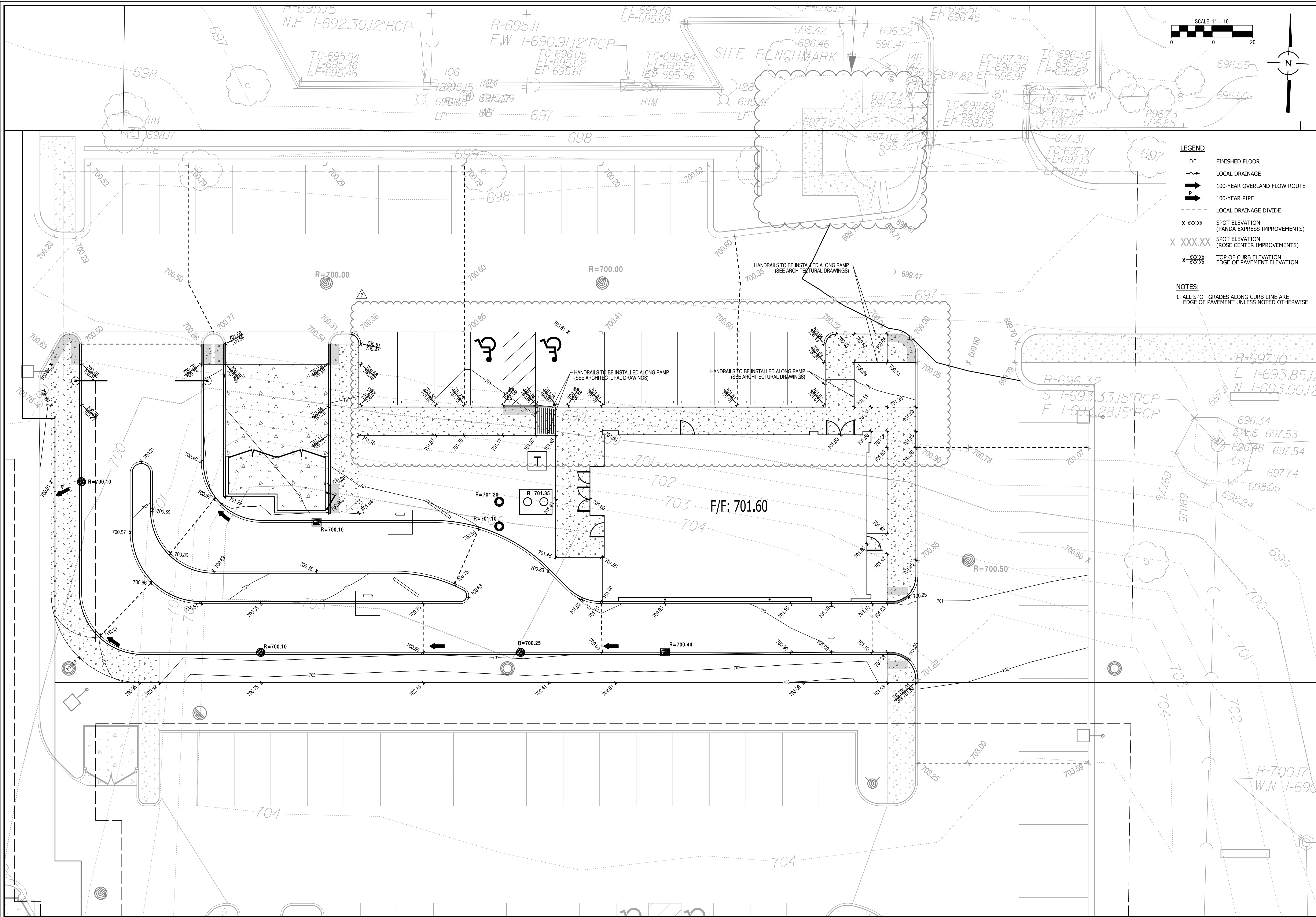

- LEGEND**
- F/F FINISHED FLOOR
  - LOCAL DRAINAGE
  - 100-YEAR OVERLAND FLOW ROUTE
  - 100-YEAR PIPE
  - LOCAL DRAINAGE DIVIDE
  - x XXX.XX SPOT ELEVATION (PANDA EXPRESS IMPROVEMENTS)
  - X XXX.XX SPOT ELEVATION (ROSE CENTER IMPROVEMENTS)
  - X XXX.XX TOP OF CURB ELEVATION
  - X XXX.XX EDGE OF PAVEMENT ELEVATION

**NOTES:**  
 1. ALL SPOT GRADES ALONG CURB LINE ARE EDGE OF PAVEMENT UNLESS NOTED OTHERWISE.

PER CITY REVIEW		NO.	DATE	REMARKS
3/6/23	PER CITY REVIEW	1		
3/23/23	PER CITY REVIEW	2		

CONSULTING ENGINEERS		SITE DEVELOPMENT ENGINEERS		LAND SURVEYORS	
<b>GRADING PLAN</b> <b>ROSE CENTER LOCKPORT</b> <b>LOT 1A - PANDA EXPRESS</b> LOCKPORT, ILLINOIS					
224 1/2 N. Liberty Street, Morris, Illinois 60450 Phone: (615) 941-0260 Fax: (615) 941-0263					
 <b>SPACECO INC.</b>					
FILENAME: CS_5225.03-GR1					
DATE: 01/30/23					
JOB NO. 5225.03-M					
SHEET <b>GR1</b> 5 OF 11					

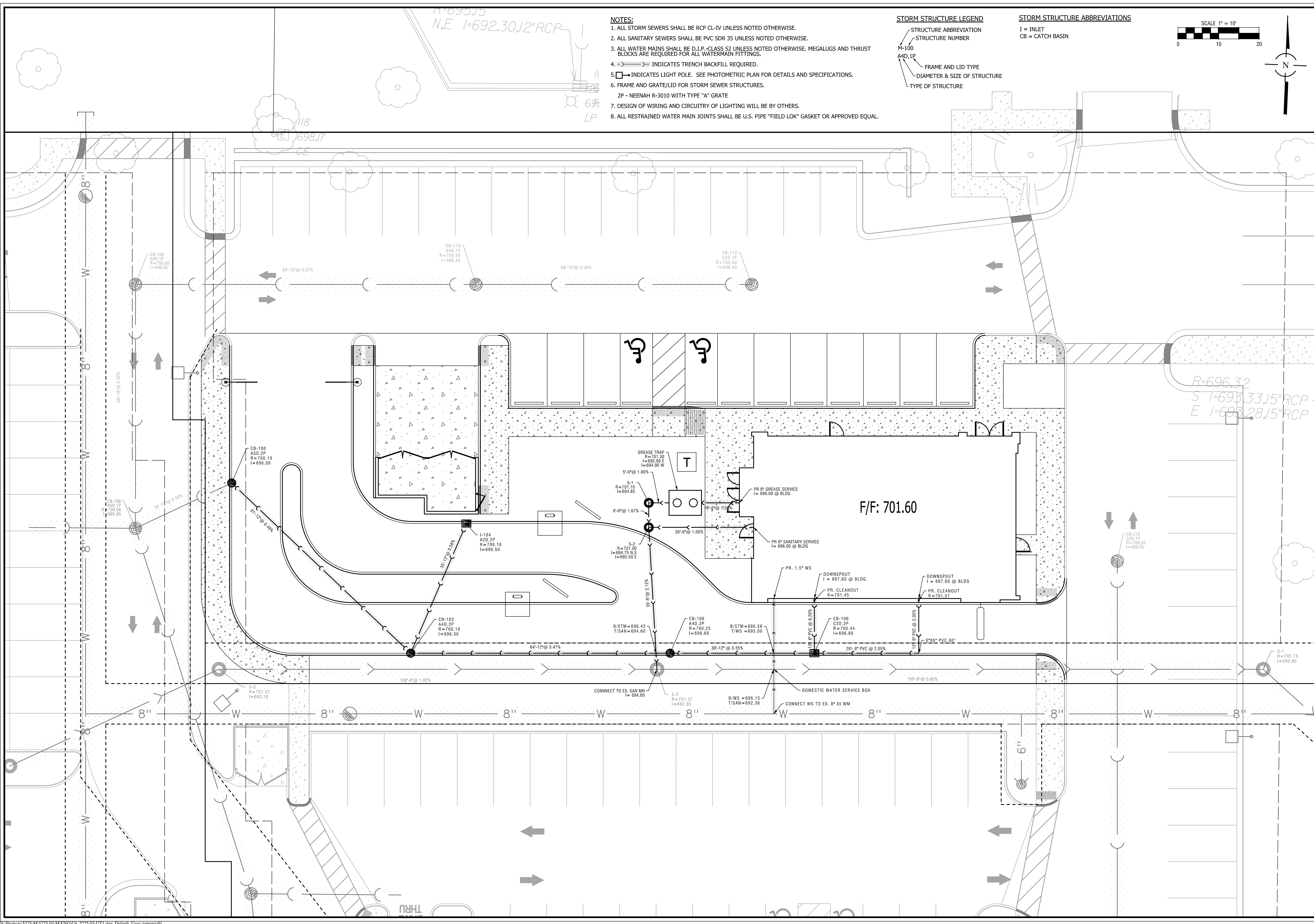

- NOTES:**
1. ALL STORM SEWERS SHALL BE RCP CL-IV UNLESS NOTED OTHERWISE.
  2. ALL SANITARY SEWERS SHALL BE PVC SDR 35 UNLESS NOTED OTHERWISE.
  3. ALL WATER MAINS SHALL BE D.I.P.-CLASS 52 UNLESS NOTED OTHERWISE. MEGALUGS AND THRUST BLOCKS ARE REQUIRED FOR ALL WATERMAIN FITTINGS.
  4. INDICATES TRENCH BACKFILL REQUIRED.
  5. INDICATES LIGHT POLE. SEE PHOTOMETRIC PLAN FOR DETAILS AND SPECIFICATIONS.
  6. FRAME AND GRATE/LID FOR STORM SEWER STRUCTURES.  
2P - NEENAH R-3010 WITH TYPE "A" GRATE
  7. DESIGN OF WIRING AND CIRCUITRY OF LIGHTING WILL BE BY OTHERS.
  8. ALL RESTRAINED WATER MAIN JOINTS SHALL BE U.S. PIPE "FIELD LOK" GASKET OR APPROVED EQUAL.

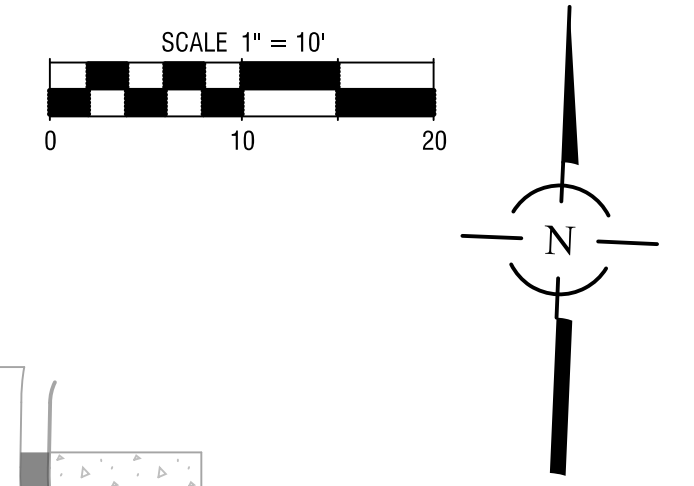
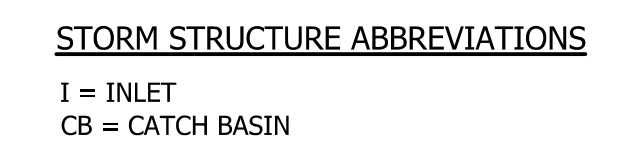
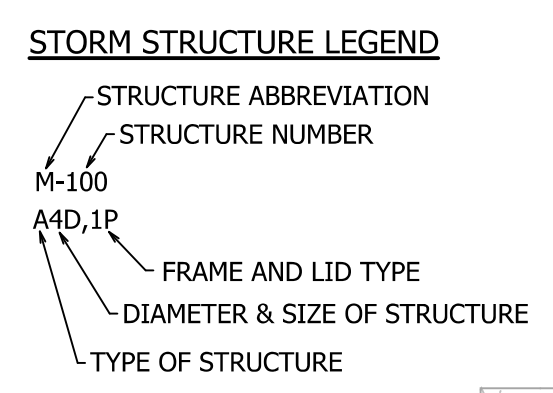

NO.	DATE	REMARKS

NO.	DATE	REMARKS
1	3/6/23	PER CITY REVIEW
2	3/23/23	PER CITY REVIEW

**UTILITY PLAN**  
**ROSE CENTER LOCKPORT**  
**LOT 1A - PANDA EXPRESS**  
 LOCKPORT, ILLINOIS

**CONSULTING ENGINEERS**  
**SITE DEVELOPMENT ENGINEERS**  
**LAND SURVEYORS**

224 1/2 N. Liberty Street,  
 Morris, Illinois 60450  
 Phone: (615) 941-0260 Fax: (615) 941-0263

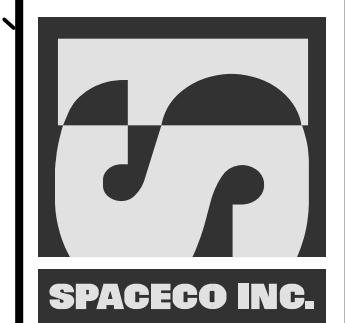

FILENAME: C6_5225.03-UT1
DATE: 01/30/23
JOB NO. 5225.03-M
SHEET <b>UT1</b> 6 OF 11

This Soil Erosion & Sediment Control (SESC) Plan has been prepared to fulfill one of the requirements of the National Pollutant Discharge Elimination System (NPDES) General Permit No. ILR10-\_\_\_\_\_. The SESC Plan should be maintained on site as an integral component of the Storm Water Pollution Prevention Plan (SWPPP). The SWPPP, including the SESC Plan, should be amended whenever there is a change in design, construction, operation, or maintenance, which has a significant effect on the potential for the discharge of pollutants to the Waters of the State and which has not otherwise been addressed in the SWPPP. The SWPPP shall also be amended if it proves to be ineffective in eliminating or significantly minimizing pollutants, or in otherwise achieving the general objectives of controlling pollutants in storm water discharges associated with construction site activity. In addition, the SWPPP shall be amended to identify any new contractor and/or subcontractor that will implement a measure of the SWPPP.

A. The following is a description of the nature of the construction activity:  
Construction of the exterior road network for a commercial development center.

B. The following is a description of the intended sequence of construction activities which will disturb soils for major portions of the construction site:  
Describe proposed construction sequence, sample follows:

- 1) Install perimeter sediment control measures
- a) Selective vegetation removal for silt fence installation
- b) Silt fence installation
- c) Construction fencing around areas not to be disturbed
- d) Stabilized construction entrance
- e) Clear and grub (as necessary)
- f) Construct sediment trapping devices (sediment traps, sediment basins, etc.)
- g) Construct detention facilities and outlet control structure with restrictor & temporary perforated pipe
- h) Strip topsoil, stockpile topsoil and grade site
- i) Temporarily stabilize topsoil stockpiles (seed and silt fence around toe of slope)
- j) Install storm sewer, sanitary sewer, watermain and associated inlet & outlet protection
- k) Permanently stabilize detention basins with seed and erosion control blanket
- l) Temporarily stabilize all areas including lots which have reached mass grade
- m) Install roadways
- n) Permanently stabilize all outdoor areas
- o) Install buildings and other individual lots
- p) Permanently stabilize lots
- q) Remove all temporary soil erosion and sediment control measures after the site is stabilized with vegetation

C. The site has a total acreage of approximately 6.24 acres. Construction activity will disturb approximately 0.433 acres of the site.

D. 1) An estimated runoff coefficient of the site after construction activities are completed is 0.85.  
2) Existing data describing the soil or quality of any discharge from the site is included in N/A.

- E. Refer to Sheets GR1 - UT1 for a site plan indicating:
- 1) drainage patterns;
  - 2) approximate slopes anticipated before and after major grading activities;
  - 3) locations where vehicles enter or exit the site and controls to minimize off-site sediment tracking;
  - 4) areas of soil disturbance;
  - 5) the location of major structural and nonstructural controls;
  - 6) the location of areas where stabilization practices are expected to occur;
  - 7) surface waters (including wetlands); and
  - 8) locations where storm water is discharged to a surface water.

F. 1) The name of the receiving water(s) is/are: Private Storm Sewer.  
2) The name of the ultimate receiving water is: DES PLAINES RIVER.  
3) The extent of wetland acreage at the site is N/A acres.

- G. Potential sources of pollution associated with this construction activity may include:
- sediment from disturbed soils
  - portable sanitary stations
  - fuel tanks
  - staging areas
  - waste containers
  - construction storage areas
  - oil or other petroleum products
  - adhesives
  - tires
  - solvents
  - detergents
  - fertilizers
  - raw materials (e.g., bagged portland cement)
  - construction debris
  - landscape waste
  - concrete and concrete trucks
  - litter

2. CONTROLS  
This section of the SESC Plan addresses the various controls that should be implemented for each of the major construction activities described in the "Site Description" section. For each measure identified in the SWPPP, the contractor(s) shall implement the measure should be identified. All contractors and subcontractors that are identified should be required to sign a copy of the certification statement from Part IV.F. of the ILR10 Permit (in accordance with Part VI.G. - Signatory Requirements, of the ILR10 Permit). All signed certification statements should be maintained in the SWPPP.

A. Approved State or Local Plans  
The management practices, controls and other provisions contained in the SWPPP should be at least as protective as the requirements contained in the Illinois Environmental Protection Agency's (IEPA) and the United States Department of Agriculture Resource Conservation Service Illinois Urban Manual, 2012. Replacements specified in sediment and erosion control site plans or site permits or storm water management site plans or site permits approved by local officials that are applicable to protecting surface water resources are, upon submittal of a Notice of Intent (NOI) to be authorized to discharge under the ILR10 permit, incorporated by reference and are enforceable under the ILR10 permit even if they are not specifically included in a SWPPP required under the ILR10 permit. This provision does not apply to provisions of master plans, comprehensive plans, non-enforceable guidelines or technical guidance documents that are not identified in a specific plan or permit that is issued for the construction site.

The soil erosion and sediment control measures for this site should meet the requirements of the following agencies:  
- Lockport  
- Will County  
- IEPA  
- U.S. Army Corps of Engineers

B. Control Implementation Schedule  
Best Management Practices will be implemented on an as-needed basis to protect water quality. Perimeter controls of the site should be installed prior to soil disturbance (excluding soil disturbance necessary to install the controls), including demolition activities. Perimeter controls, including the silt fence, should be actively maintained until final stabilization of those portions of the site upwind of the perimeter control. Stabilized construction entrance(s) and sediment traps should be installed as described in the intended sequence of construction activities. The contractor is responsible for the adequate protection (including sediment control) of existing sewers and sewer structures during construction operations. As necessary, the appropriate sediment control measure should be installed prior to land disturbing activities.

Stabilization measures should be initiated where construction activities have temporarily or permanently ceased, in accordance with Local and State requirements, as described below. Once construction activity in an area has permanently ceased, that area should be permanently stabilized. Temporary perimeter controls should be removed after final stabilization of those portions of the site upwind of the perimeter control.

C. Erosion and Sediment Controls  
The appropriate soil erosion and sediment controls should be implemented on site and should be modified to reflect the current phase of construction. All temporary sediment and erosion control measures should be repaired or replaced as soon as practicable to maintain NPDES compliance. Permittee or an authorized agent is responsible for inspecting all sediment and erosion control measures at a minimum of every 7 calendar days and within 24 hours, or one working day, of the end of a 0.5-inch (or greater) rain event.

Unless otherwise indicated, all vegetative and structural erosion and sediment control practices should be installed to the Standard Practice. The contractor is responsible for the installation of any additional erosion and sediment control measures necessary to minimize erosion and sedimentation as determined by the Engineer or Primary Contact.

- 1) Stabilization Practices - Areas that will not be paved or covered with non-erosive material should be stabilized using procedures in substantial conformance with the Illinois Urban Manual. This SESC Plan includes site-specific soil erosion and sediment control measures. Additional erosion controls should be implemented as necessary, as determined by the Engineer or Primary Contact.

The following temporary and permanent stabilization practices, at a minimum, are proposed:

- permanent seeding
- temporary seeding
- erosion control blanket
- other measures

Site-specific scheduling of the implementation of these practices is included in the Soil Protection Chart. A record of the dates when major grading activities occur, when construction activities cease on a portion of the site, and when stabilization measures are initiated should be included in the SWPPP.

Stabilization of disturbed areas must be initiated within 1 working day of permanent or temporary cessation of earth activities and shall be completed as soon as possible but not later than 14 days from the initiation of stabilization work in an area. Exceptions to these time frames are specified below.

- a. Where the initiation of stabilization measures is precluded by snow cover, stabilization measures shall be initiated as soon as practicable.
- b. On areas where construction activity has temporarily ceased and will resume after 14 days, a temporary stabilization method can be used. Temporary stabilization techniques and materials shall conform to the SWPPP.

2) Structural Practices - Provided below is a description of structural practices that should be implemented, to the degree attainable to divert flows from exposed soils, store flows or otherwise limit runoff and the discharge of pollutants from exposed areas of the site. Structural practices should be placed on upland soils to the degree practicable. The installation of the following devices may be subject to Section 404 of the Clean Water Act:

- stabilized construction entrance
- silt fence
- sediment traps (provide locations and dimensions in plan set)
- other measures

D. Storm Water Management  
Provided below is a description of measures that will be installed during the construction process to control the pollutants in storm water discharges that will occur after the construction operations have been completed. The installation of these devices may be subject to Section 404 of the Clean Water Act.

1) The practices selected for implementation were determined on the basis of technical guidance contained in IEPA's Illinois Urban Manual, Federal, State, and/or Local Requirements. The storm water management measures include:

- detention basins (wet basins, dry basins, etc.)
- retention basins
- vegetated swales
- infiltration trenches
- other measures

2) Velocity dissipation devices, such as rip-rap aprons at flared end sections or level spreaders, shall be placed at discharge locations and along the length of any outfall channel as necessary to provide a non-erosive velocity flow from the structure to a watercourse so that the natural physical and biological characteristics and functions are maintained and protected (e.g., maintenance of hydrologic conditions, such as the hydroperiod and hydrodynamics present prior to the initiation of construction activities).

E. Waste Management  
Solid waste materials including trash, construction debris, excess construction materials, machinery, tools and other items will be collected and disposed of off site by the contractor. The contractor is responsible to acquire the permit required for such disposal. Burning on site will not be permitted. No solid materials, including building materials, shall be discharged to Waters of the State, except as authorized by a Section 404 permit. All waste materials should be collected and stored in approved receptacles. No wastes should be placed in any location other than in the approved containers appropriate for the materials being discarded. There should be no open burning of materials in dumpsters or other containers which may leak. Receptacles with deficiencies should be replaced as soon as possible and the appropriate clean-up procedure should take place. If necessary, construction waste material is not to be buried on site. Waste disposal should comply with all Local, State, and Federal regulations.

On-site hazardous material storage should be minimized and stored in labeled, separate receptacles from non-hazardous waste. All hazardous waste should be disposed of in the manner specified by Local or State regulations or by the manufacturer.

F. Concrete Waste Management  
Concrete waste or washout should not be allowed in the street or allowed to reach a storm water drainage system or watercourse. When practicable, a sign should be posted at each location to identify the washout. To the extent practicable, concrete washout areas should be located a reasonable distance from a storm water drainage inlet or watercourse, and should be located at least 10 feet behind the curb. If the washout area is adjacent to a paved road, a stabilized entrance that meets Illinois Urban Manual standards should be installed at each washout area.

The containment facilities should be of sufficient volume to completely contain all liquid and concrete waste materials including enough capacity for anticipated levels of rainfallwater. The dried concrete waste material should be picked up and disposed of properly when the capacity is reached. Hardened concrete can be efficiently recycled and used again on site (as approved by the Engineer) or hauled off site to an appropriate landfill.

G. Concrete Cutting  
Concrete waste management should be implemented to contain and dispose of saw-cutting slurries. Concrete cutting should not take place during or immediately after a rainfall event. Waste generated from concrete cutting should be cleaned-up and disposed into the concrete washout facility as described above.

H. Vehicle Storage and Maintenance  
When not in use, construction vehicles should be stored in a designated area(s) outside of the regulatory floodplain, away from any natural or created watercourse, pond, drainage-way or storm drain. Controls should be installed to minimize the potential of runoff from the storage area(s) from reaching storm drains or water courses. Vehicle maintenance (including both routine maintenance as well as on-site repairs) should be made within a designated area(s) to prevent the migration of mechanical fluids (oil, antifreeze, etc.) into watercourses, wetlands or storm drains. Dip pans or absorbent pads should be used for all vehicle and equipment maintenance activities that involve grease, oil, solvents, or other vehicle fluids. Construction vehicles should be inspected frequently to identify any leaks; leaks should be repaired immediately or the vehicle should be removed from site. Dispose of all used oil, antifreeze, solvents and other vehicle-related chemicals in accordance with United States Environmental Protection Agency (USEPA) and IEPA regulations and per Material Safety Data Sheet (MSDS) and/or manufacturer instructions. Contractors should immediately report spills to the Primary Contact.

I. Material Storage and Good Housekeeping  
Materials and/or containers should be stored in a manner that minimizes the potential to discharge into storm drains or watercourses. An on-site area should be designated for material delivery and storage. All materials kept on site should be stored in their original containers with legible labels, and if possible, under a roof or other enclosure. Labels should be replaced if damaged or difficult to read. Bermed-off storage areas are an acceptable control measure to prevent contamination of storm water. MSDS should be available for referencing clean-up procedures. Any release of chemicals/containers should be immediately related to and disposed of properly. Contractors should immediately report all spills to the Primary Contact, who should notify the appropriate agencies, if needed.

To reduce the risks associated with hazardous materials on site, hazardous products should be kept in original containers unless they are not re-sealable. The original labels and MSDS should be retained on site at all times. Hazardous materials and all other material on site should be stored in accordance with manufacturer or MSDS specifications. Where disposing of hazardous materials, follow manufacturer or Local and State recommended methods.

The following good housekeeping practices should be followed on site during the construction project:

- An effort should be made to store only enough product regularly to do the job.
- All materials stored on site should be stored in a neat, orderly manner in their appropriate containers and adequately protected from the environment.
- Products should be kept in their original containers with the original manufacturer's label.
- Substances should not be mixed with one another unless recommended by the manufacturer.
- Operations should be observed as necessary to ensure proper use and disposal of materials on site.
- Whenever possible, all of a product should be used up before disposing of the container.
- Manufacturer's recommendations for proper use and disposal should be followed.

J. Management of Portable Sanitary Stations  
To the extent practicable, portable sanitary stations should be located in an area that does not drain to any protected natural areas, Waters of the State, or storm water structures and should be anchored to the ground to prevent from tipping over. Portable sanitary stations located on impervious surfaces should be placed on top of a secondary containment device, or be surrounded by a control device (e.g., gravel-bag berm). The contractor should not create or allow unsanitary conditions. Sanitary waste should be disposed of in accordance with applicable State and/or Local regulations.

K. Spill Prevention and Clean-Up Procedures  
Manufacturer's recommended methods for spill clean-up should be available and site personnel should be made aware of the procedures and the location of the information and clean-up supplies. Materials and equipment necessary for spill clean-up should be kept in the main storage area on site. Equipment and materials should include, but are not limited to, brooms, dust pans, mops, rags, gloves, goggles, kitty litter, sand, sawdust and plastic and/or metal trash containers specifically for this purpose. Discharges of a spill caused by a spill (e.g., a spill of oil into a sewer storm sewer or Waters of the State) are not authorized by the ILR10 permit. If a spill occurs, notify the Primary Contact immediately. The construction site should have the capacity to control, contain, and remove spills, if they occur. Spills should be cleaned up immediately (after discovery) in accordance with MSDS and should not be buried on site or washed into storm sewer drainage inlets, drainage-ways, or Waters of the State.

Spills in excess of Federal Reportable Quantities (as established under 40 CFR Parts 110, 117, or 302), should be reported to the National Response Center by calling (800) 424-8002. MSDS often include information on Federal Reportable Quantities for materials. Spills of toxic or hazardous materials should be reported to the appropriate State or local government agency, as required. When cleaning up a spill, the area should be kept well ventilated and appropriate personal protective equipment should be used to minimize injury from contact with a hazardous substance.

In addition to the good housekeeping and other management practices discussed in the previous sections of these Notes, the following minimum practices should be followed to reduce the risk of spills:

- On-site vehicles should be monitored for leaks and should receive regular preventative maintenance to reduce the chance of leakage.
- Petroleum products should be stored in tightly sealed and clearly labeled containers.
- Contractors should follow the manufacturer's recommendations for proper use, storage, and disposal of materials. Excess materials should be disposed of according to the manufacturer's instructions or State and Local regulations, and should not be discharged to the storm sewer or waterbody.

L. De-Watering Operations  
During de-watering/pumping operations, only uncontaminated water should be allowed to discharge to protected natural areas, Waters of the State, or to a storm sewer system (in accordance with Local permits). Inlet hoses should be placed in a stabilized sump pit or floated on the surface of the water in order to limit the amount of sediment intake. Pumping operations may be discharged to a stabilized area that consists of an energy dissipating device (e.g., stone), sediment filter bag, or both. Adequate erosion controls should be used during de-watering operations as necessary. Stabilized conveyance channels should be installed to direct water to the desired location as applicable. Additional control measures may be installed at the outlet area at the discretion of the Primary Contact or Engineer.

M. Off-Site Vehicle Tracking  
The site should have one or more stabilized construction entrances in conformance with the Plan details. Stabilized construction entrance(s) should be installed to help reduce vehicle tracking of sediments. Streets should be swept as needed to reduce excess sediment, dirt, or stone tracked from the site. Maintenance may include top dressing the stabilizes with additional stone and removing top layers of stone and sediment, as needed. Vehicles hauling erodible material to or from the construction site should be covered with a tarp.

N. Topsoil Stockpile Management  
If topsoil is to be stockpiled at the site, select a location so that it will not erode, block drainage, or interfere with work on site. Topsoil stockpiles should not be located in the 100-year floodplain or designated buffer protecting Waters of the State. During construction of the project, soil stockpiles should be stabilized or protected with sediment trapping measures. Perimeter controls, such as silt fence, should be placed around the stockpile immediately. Stabilization of the stockpile should be completed if the stockpile is to remain undisturbed for longer than fourteen days.

O. Dust Control  
Dust control should be implemented on site as necessary. Repetitive treatment should be applied as needed to accomplish control when temporary dust control measures are used. A water truck should be present on site (or available) for sprinkling/irrigation to limit the amount of dust leaving the site. Watering should be applied daily (or more frequently) to be effective. Caution should be used not to overwater, as that may cause erosion.  
If field observations indicate that additional protection from wind erosion (in addition to, or in place of watering) is necessary, alternative dust suppression controls should be implemented at the discretion and approval of the Engineer and/or Primary Contact.  
Street cleaning should also be used as necessary to control dust. Paved areas that have soil on them from the construction site should be cleaned as needed, utilizing a street sweeper or bucket-type endloader or scraper at the direction of the Engineer and/or Primary Contact.

3. MAINTENANCE  
Maintenance of the controls incorporated into this project should be performed as needed to assure their continued effectiveness. This includes prompt and effective repair and/or replacement of deficient control measures. The following is a description of procedures that should be used to maintain, in good and effective operating condition, erosion and sediment control measures and other protective measures identified in the SESC Plan and Standard Specifications.  
Dust control: When temporary dust control measures are used, repetitive treatment should be applied as needed to accomplish control.

Sediment filter bags: Sediment filter bags should be installed on pump outlet hoses that discharge off site or to sensitive on-site areas, and should be placed in an area that allows for the bag to be removed without producing a sediment discharge. The bags should be inspected frequently and repaired or replaced as needed.  
Silt fence: Silt fences should be inspected regularly for undercutting where the fence meets the ground, overtopping, and tears along the length of the fence. Deficiencies should be repaired immediately. Remove accumulated sediments from the fence base when the sediment reaches one-half the fence height. During final stabilization, properly dispose of any sediment that has accumulated on the silt fence. Alternative sediment control measures should be considered for areas where silt fence continually fails.

Stabilized construction entrance: The stabilized construction entrances should be maintained to prevent tracking of sediment onto public streets. Maintenance includes top dressing with additional stone and removing top layers of stone and sediment. The sediment tracked onto the public right-of-way should be removed immediately.  
Temporary sediment traps: Temporary sediment traps should be inspected after each period of significant rainfall. Remove sediment and restore the trap to its original dimensions when the sediment has accumulated to one-half the design depth of the permanent pool. Place the sediment that is removed in a designated disposal area. Check the structure for damage from erosion or piping. After all sediment-producing areas have been permanently stabilized, remove the structure and all unstable sediment. Grade the area to blend with the adjoining areas and stabilize properly.

4. INSPECTIONS  
The Permittee (or their authorized representative) will be responsible for conducting site inspections in compliance with the ILR10 NPDES Permit. After each inspection, a report should be prepared by the qualified personnel who performed the inspection. The inspection report should be maintained on site as part of the SWPPP.

Inspections should be conducted at least once every seven calendar days and within 24 hours by the end of the following work day, or the end of a storm event that is 0.5 inches or greater, or equivalent snowfall.  
Inspections may be reduced to once per month when construction activities have ceased due to frozen conditions. Weekly inspections will recommence when construction activities are conducted, or if there is 0.5" or greater rain event, or a discharge due to snowmelt occurs.  
Each inspection should include the following components:

A. Disturbed areas and areas used for the storage of materials that are exposed to precipitation should be inspected for evidence of, or the potential for, pollutants entering the drainage system. The erosion and sediment control measures identified in the SWPPP should be observed to ensure that they have been installed and are operating correctly. Where discharge points are accessible, they should be inspected to ascertain whether erosion control measures are effective in preventing significant impacts to the receiving waters. Locations where vehicles enter or exit the site should be inspected for off-site sediment tracking. All pumping operations and other potential non-storm water discharge sources should also be inspected.

B. Based on the results of the inspection, the description of potential pollutant sources identified, and the pollution prevention measures described in the SWPPP should be revised, as appropriate, as soon as practicable after the inspection. The modifications, if any, shall provide for timely implementation of any changes to the SWPPP within 7 calendar days following the inspection.

C. A report summarizing the scope of the inspection, name(s) and qualifications of personnel making the inspection, the date(s) of the inspection, major observations relating to the implementation of the SWPPP, and actions taken in accordance with paragraph B. above should be made and retained as part of the SWPPP for at least three years from the date that permit coverage expires or is terminated. The report shall be signed in accordance with Part VI.G. (Signatory Requirements) of the ILR10 NPDES Permit.

D. The Permittee shall notify the appropriate agency field operations section office by e-mail at: [epa\\_swnoncomp@illinois.gov](mailto:epa_swnoncomp@illinois.gov), telephone or fax within 24 hours of any incidence of noncompliance for any violation of the storm water pollution prevention measures during any inspection conducted or for violation of any condition of this permit. The Permittee should contact and submit within 5 days an "Incidence of Non-Compliance (INON)" report for any violation of the SWPPP observed during an inspection conducted, including those not required by the SWPPP. Submission should be on forms provided by IEPA and include specific information on the cause of non-compliance, actions which were taken to prevent any further causes of non-compliance, and a statement detailing any environmental impact, which may have resulted from the non-compliance.

E. All reports of non-compliance shall be signed by a responsible authority as defined in Part VI.G. (Signatory Requirements), of the ILR10 NPDES Permit.

F. After the initial contact has been made within the appropriate agency field operations section office, all reports of non-compliance shall be mailed to IEPA at the following address:  
Illinois Environmental Protection Agency  
Division of Water Pollution Control  
Compliance Assurance Section  
1107 North Grand Avenue East  
Post Office Box 19276  
Springfield, Illinois 62794-9276

5. NON-STORM WATER DISCHARGES  
Except for flows from fire fighting activities, possible sources of non-storm water that may be combined with storm water discharges associated with the proposed activity, are described below:

- Fire fighting activities
- Fire hydrant flushings
- Water used to wash vehicles where detergents are not used
- Water used to control dust
- Potable water sources including uncontaminated waterline flushings
- Landscape irrigation drainages
- Routine external building washdown which does not use detergents
- Pavement wash waters where spills or leaks of toxic or hazardous materials have not occurred (unless spilled materials have been removed) and where detergents have not been used.
- Uncontaminated all conditioning condensate
- Springs
- Irrigation ditches
- Uncontaminated ground water
- Foundation or footing drains where flows are not contaminated with process materials such as solvents

6. PROHIBITED NON-STORM-WATER DISCHARGES  
- Concrete and wastewater from washout of concrete (unless managed by an appropriate contact)  
- Drywall compound  
- Wastewater from washout and cleanup of stucco, paint  
- Form release oils  
- Curing compounds and other construction materials  
- Fuels, oils, or other pollutants used in vehicle or equipment operation and maintenance  
- Soaps, solvents, or detergents  
- Toxic or hazardous substances from a spill or other release  
- Any other pollutant that could cause or tend to cause water pollution  
Pollution prevention measures should be implemented for non-storm water components of the discharge.

STABILIZATION TYPE	JAN.	FEB.	MAR.	APR.	MAY	JUNE	JULY	AUG.	SEPT.	OCT.	NOV.	DEC.
PERMANENT SEEDING			A									
DORMANT SEEDING	B										B	
TEMPORARY SEEDING			C			D						
SODDING			E**									
MULCHING	F											

A	KENTUCKY BLUEGRASS 90 LBS/ACRE MIXED WITH PERENNIAL RYEGRASS 30 LBS/ACRE.	C	SPRING OATS 100 LBS/ACRE
B	KENTUCKY BLUEGRASS 135 LBS/ACRE MIXED WITH PERENNIAL RYEGRASS 45 LBS/ACRE + STRAW MULCH 2 TONS/ACRE.	D	WHEAT OR CERIAL RYE 150 LBS/ACRE.
		E	SOD
		F	STRAW MULCH 2 TONS/ACRE.

\* IRRIGATION NEEDED DURING JUNE AND JULY.  
\*\* IRRIGATION NEEDED FOR 2 TO 3 WEEKS AFTER APPLYING SOD.

SOIL PROTECTION CHART

NO.	DATE	REMARKS

NO.	DATE	REMARKS

SOIL EROSION AND SEDIMENT CONTROL PLAN - 1  
ROSE CENTER LOCKPORT  
LOT 1A - PANDA EXPRESS  
LOCKPORT, ILLINOIS

CONSULTING ENGINEERS  
SITE DEVELOPMENT ENGINEERS  
LAND SURVEYORS  
224 1/2 N. Liberty Street,  
Morris, Illinois 60450  
Phone: (615) 941-0260 Fax: (615) 941-0263



FILENAME:  
C7\_5225\_03-SE1  
DATE:  
01/30/23  
JOB NO.  
5225-03-M  
SHEET

SE1  
7 OF 11

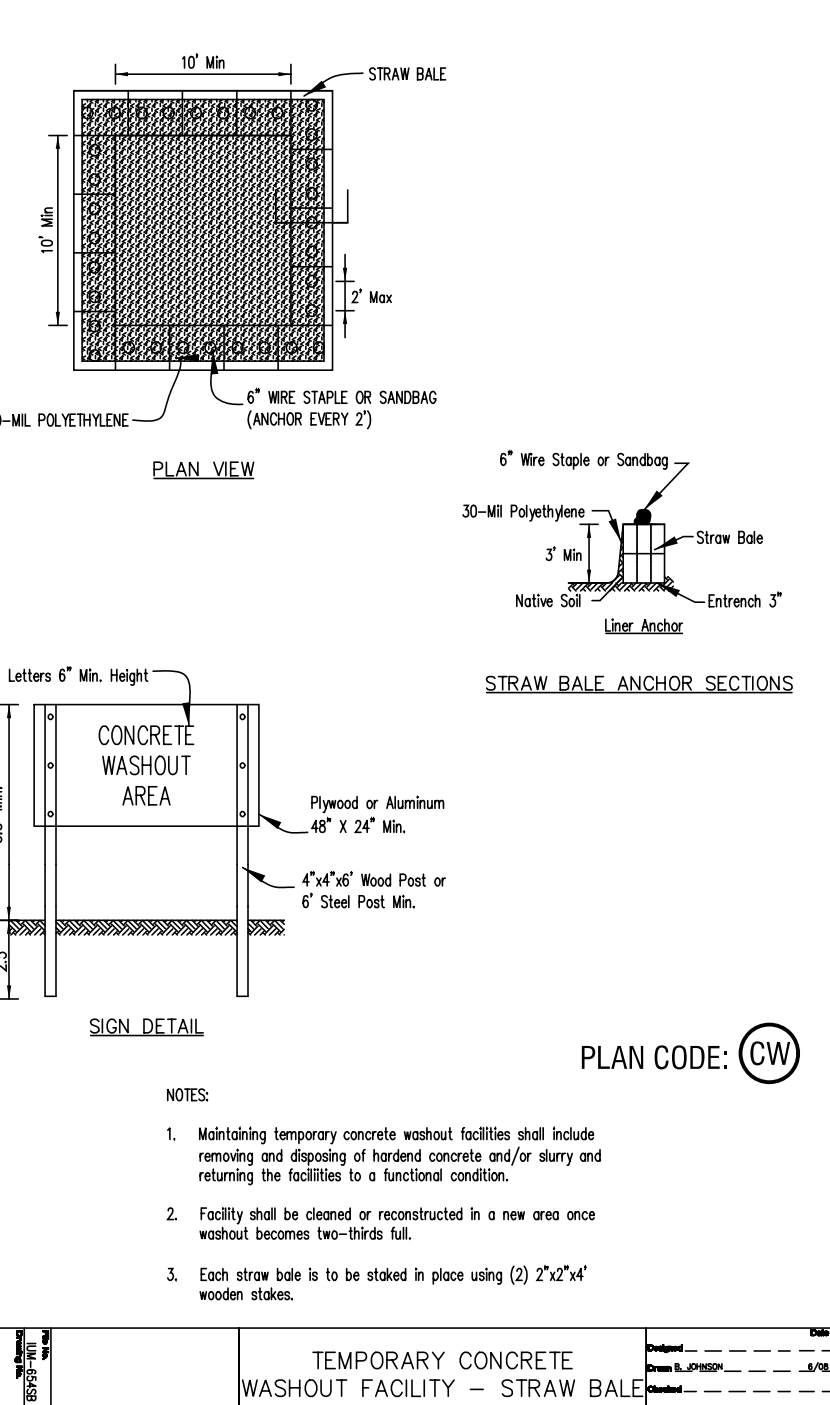
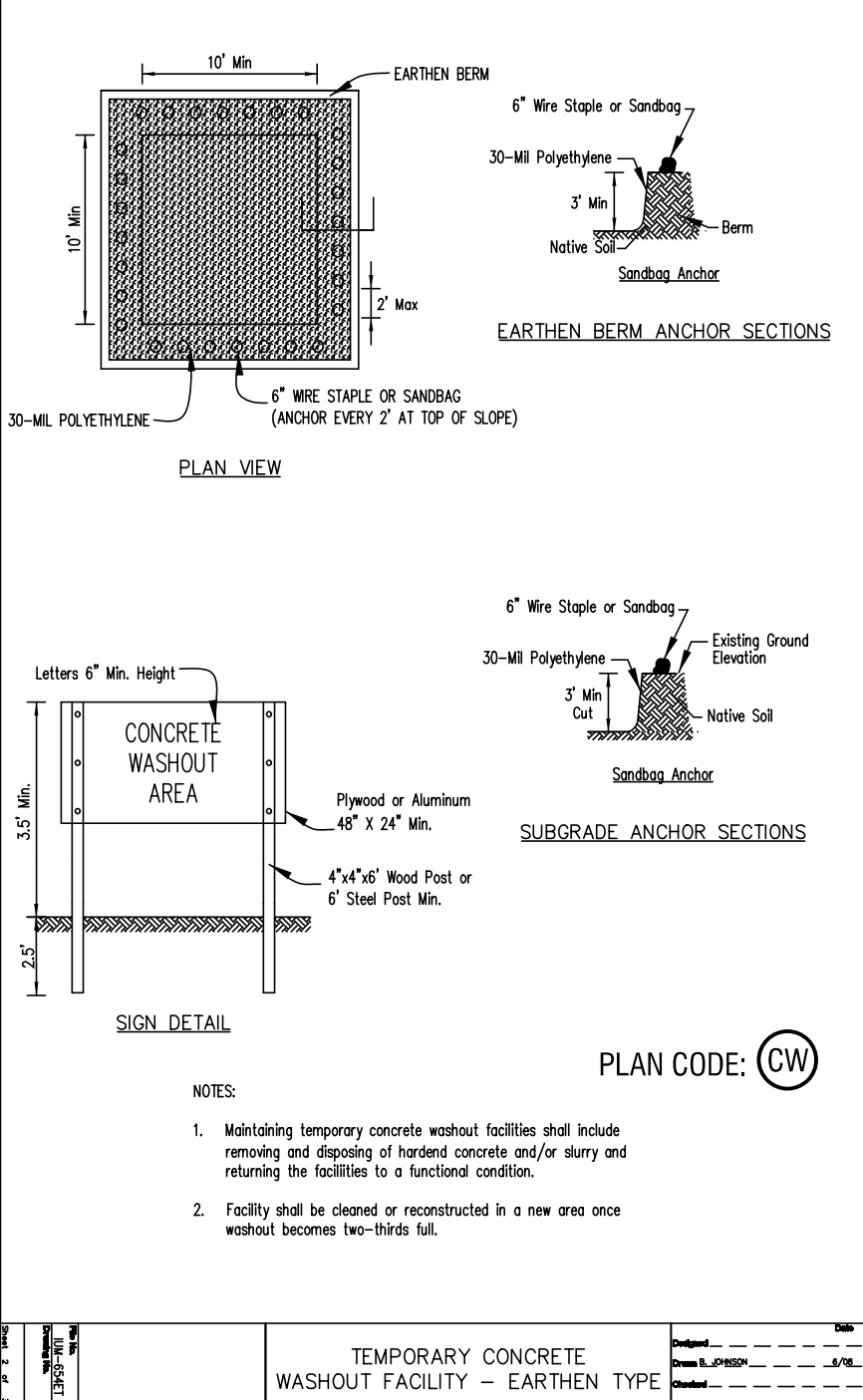
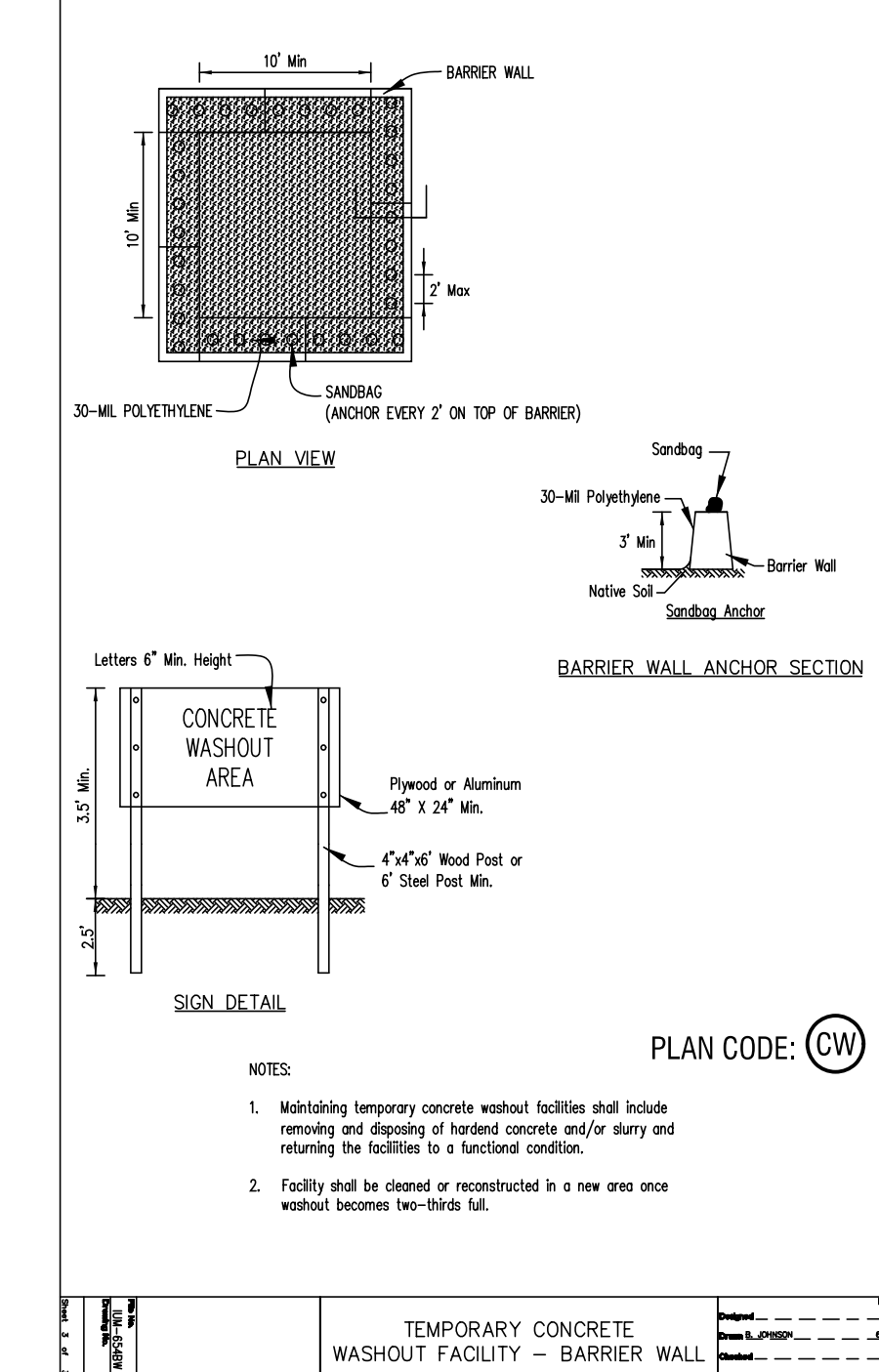
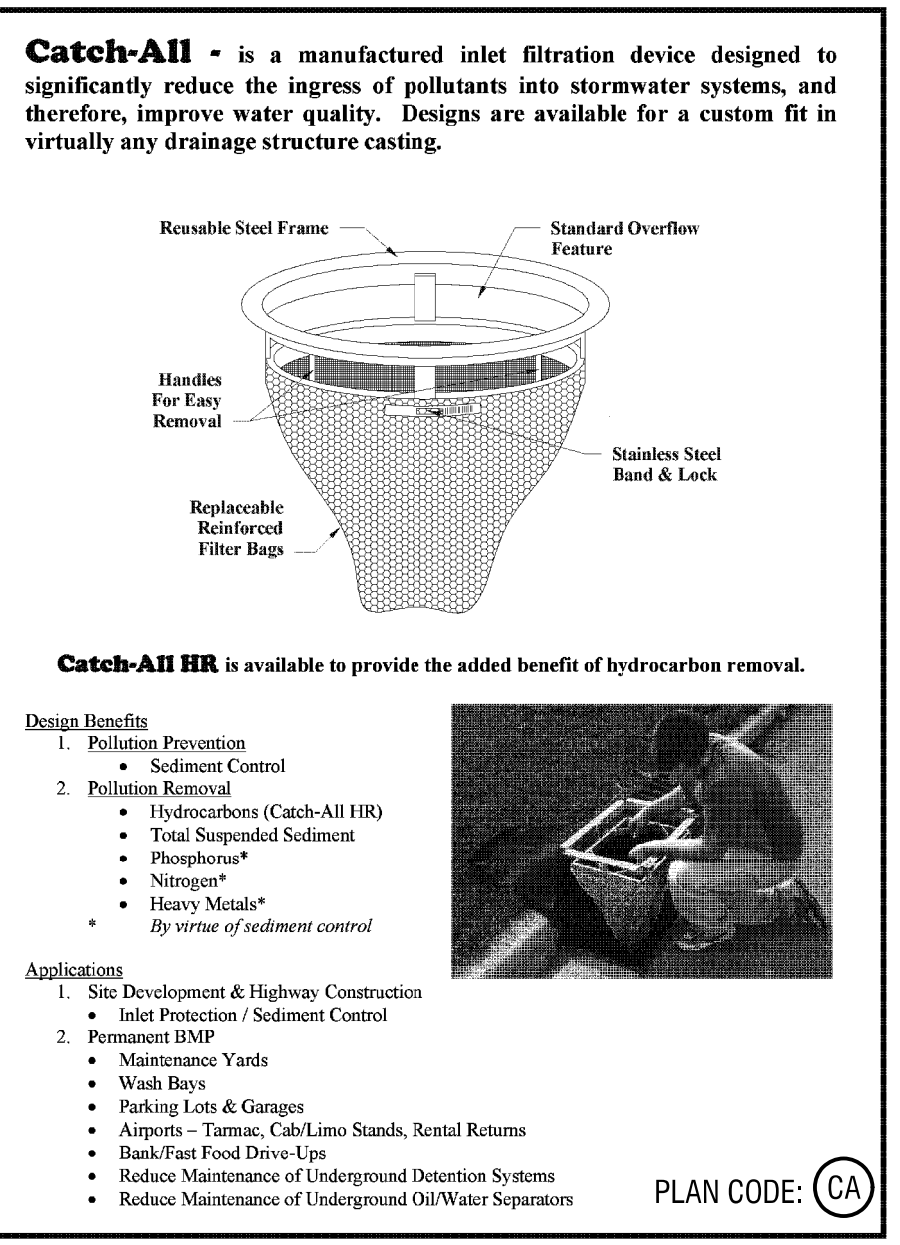
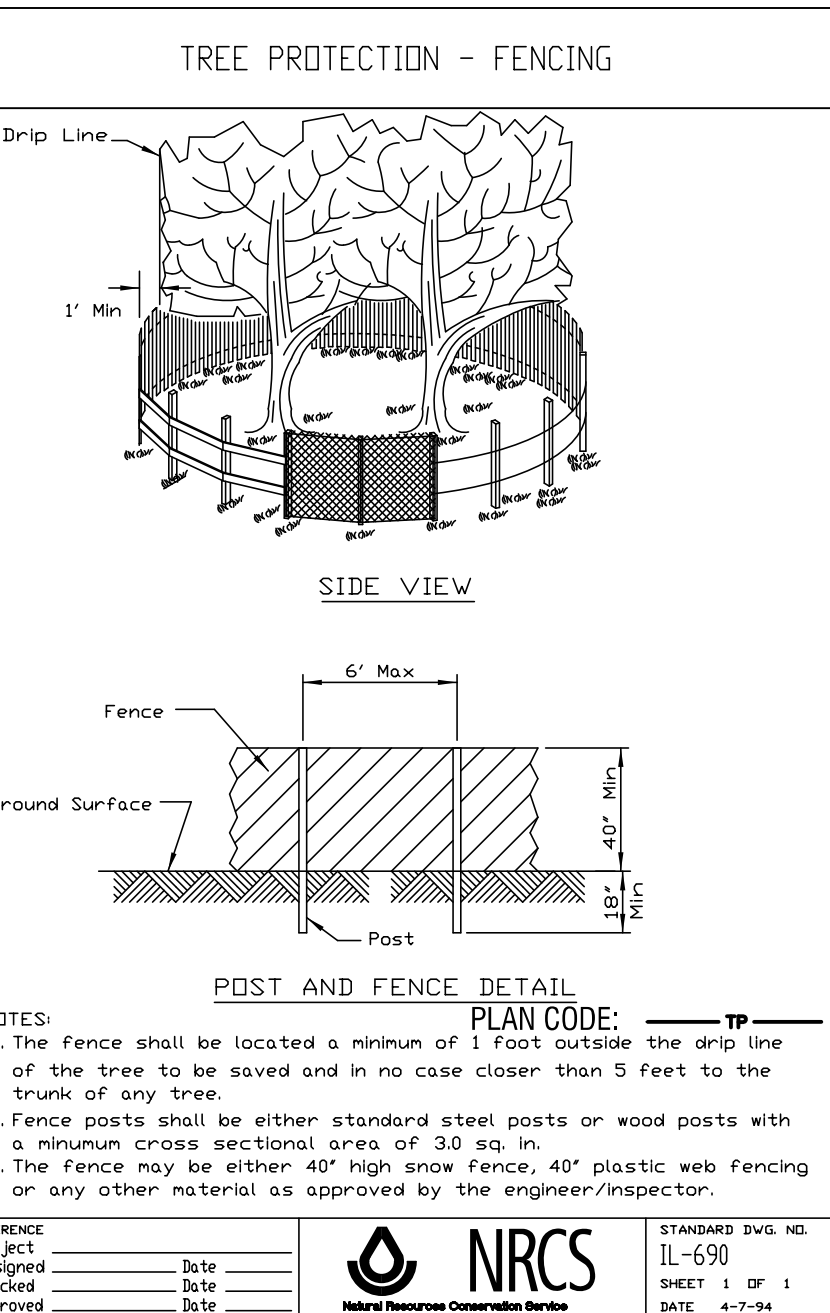
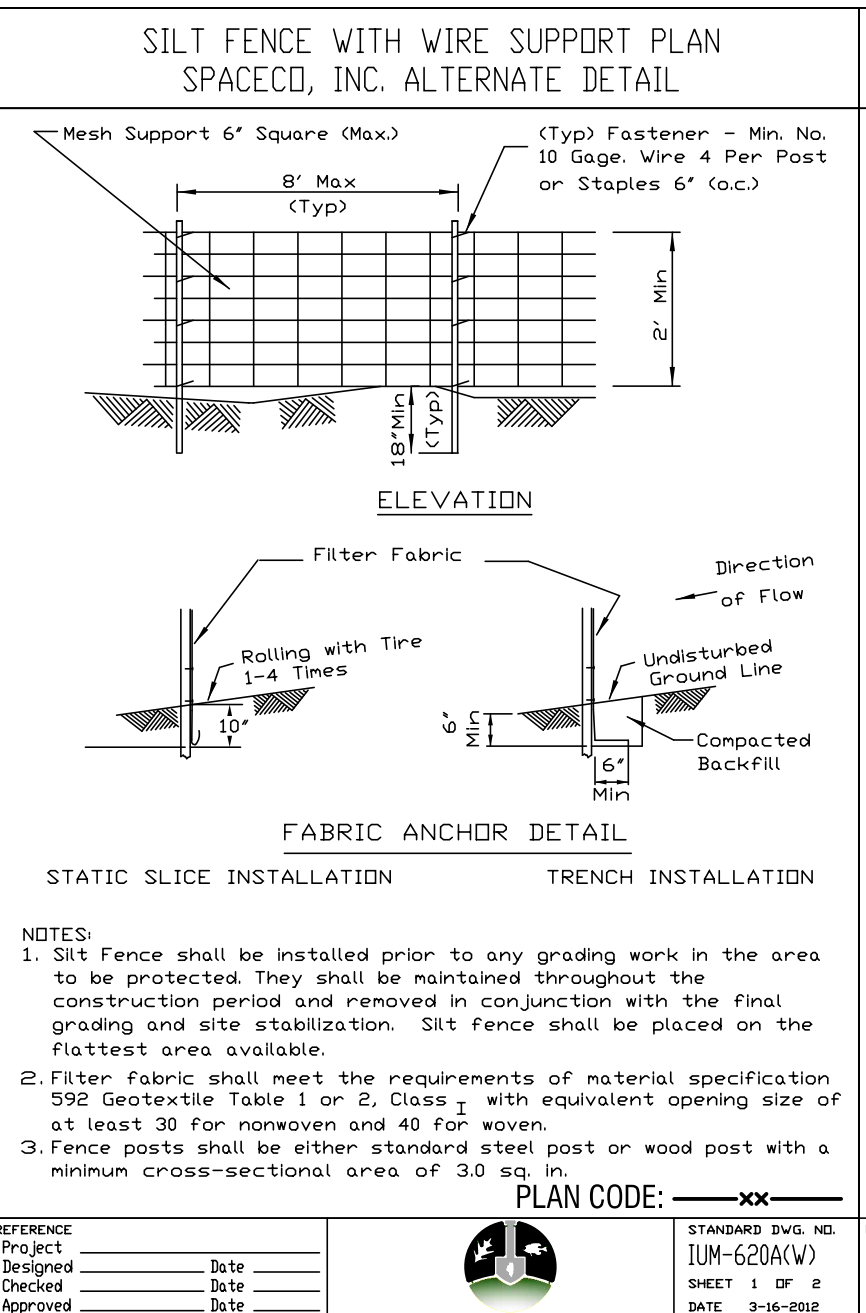
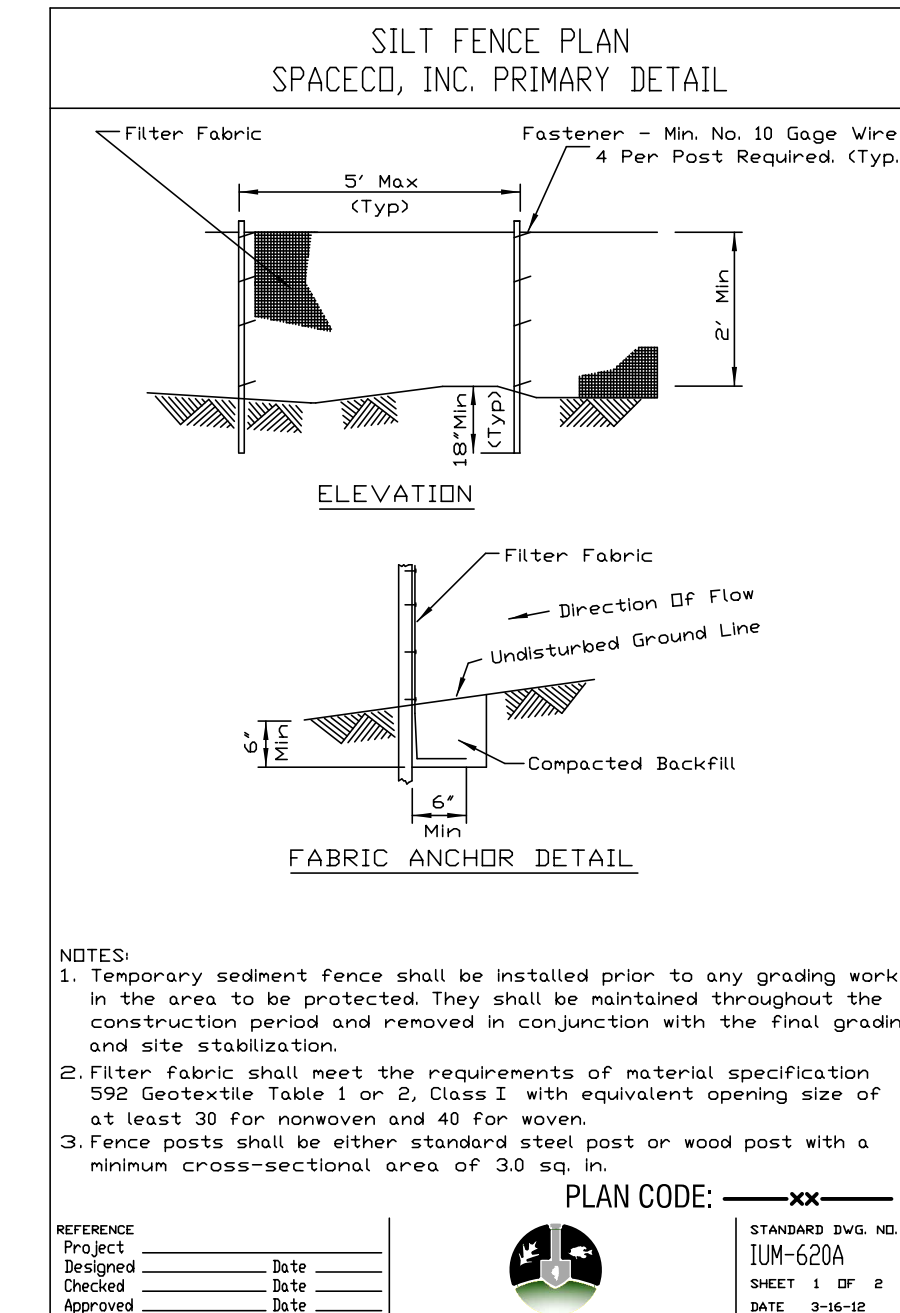
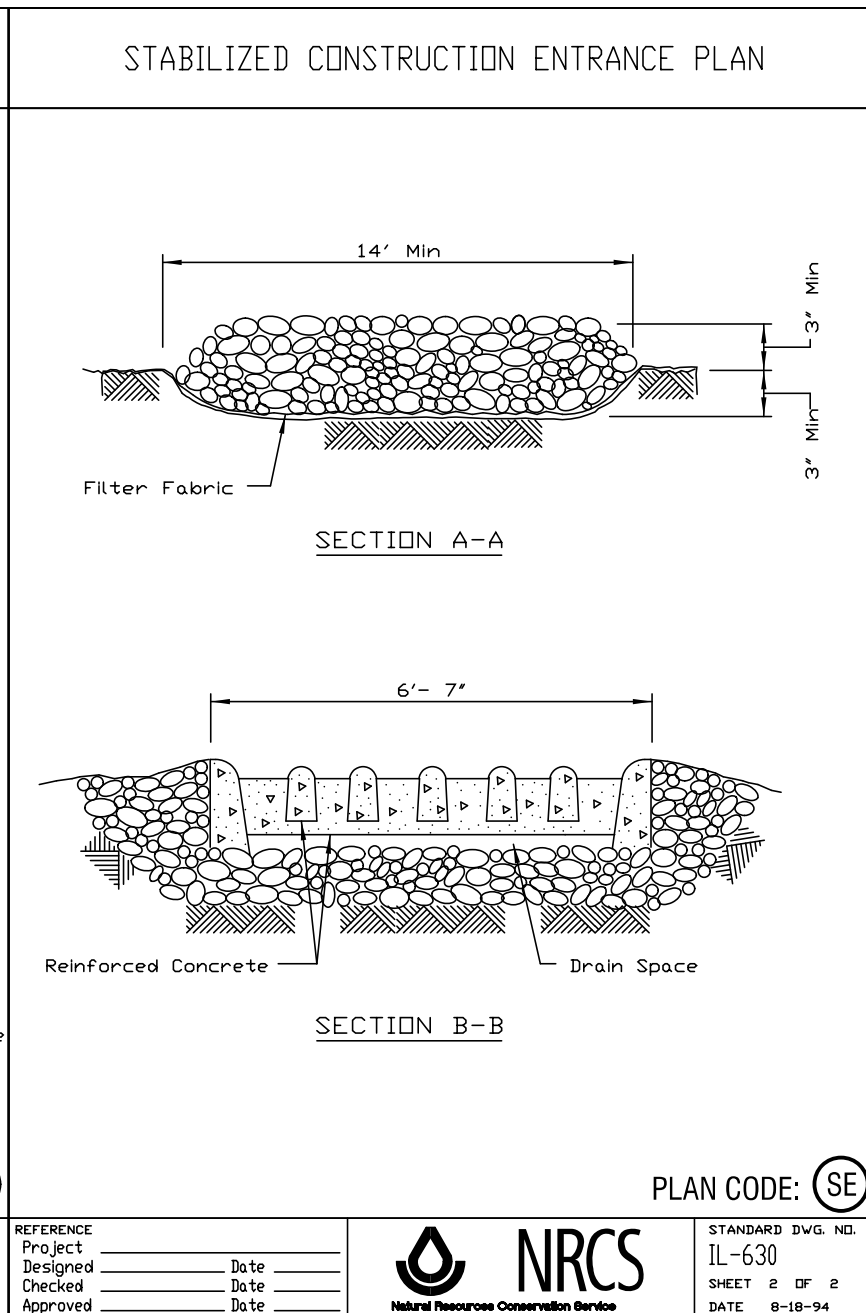
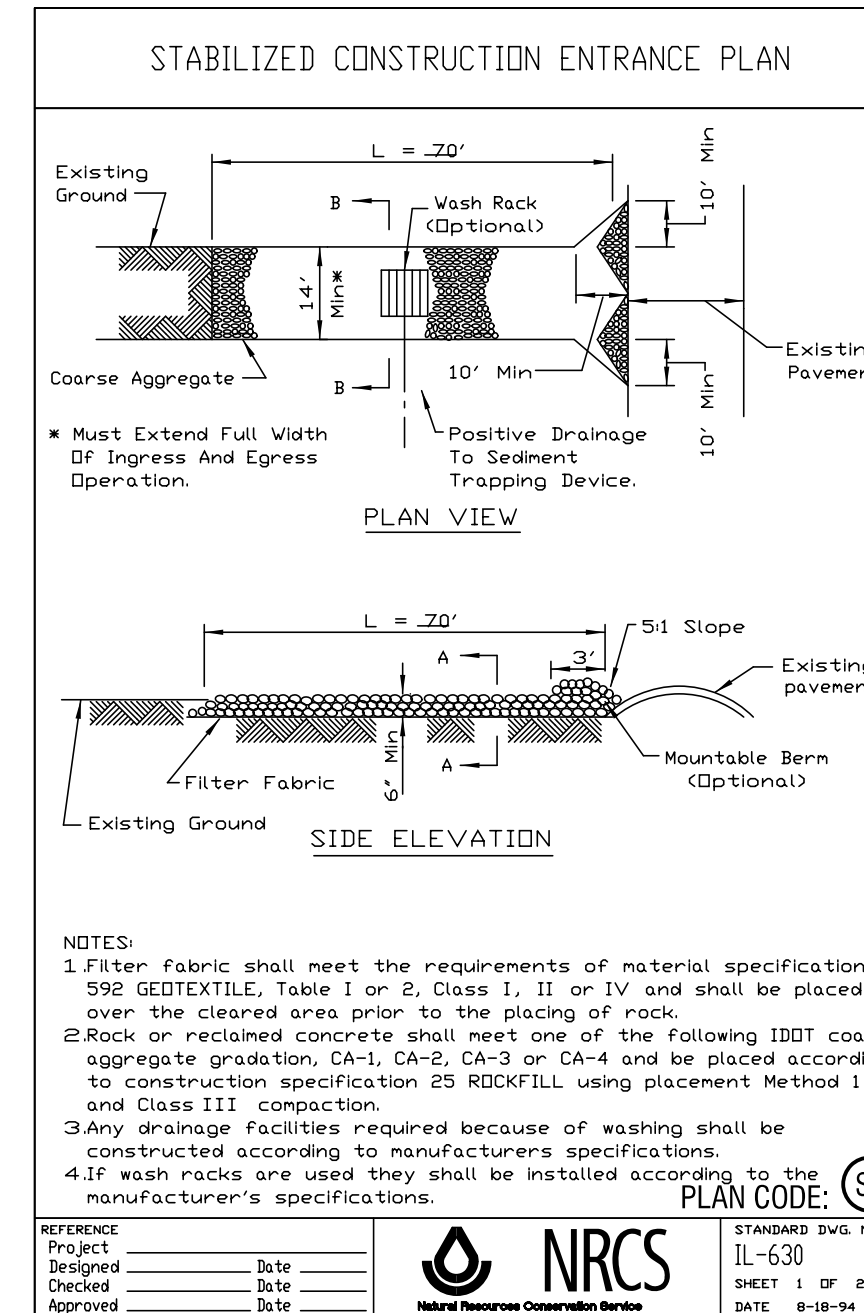
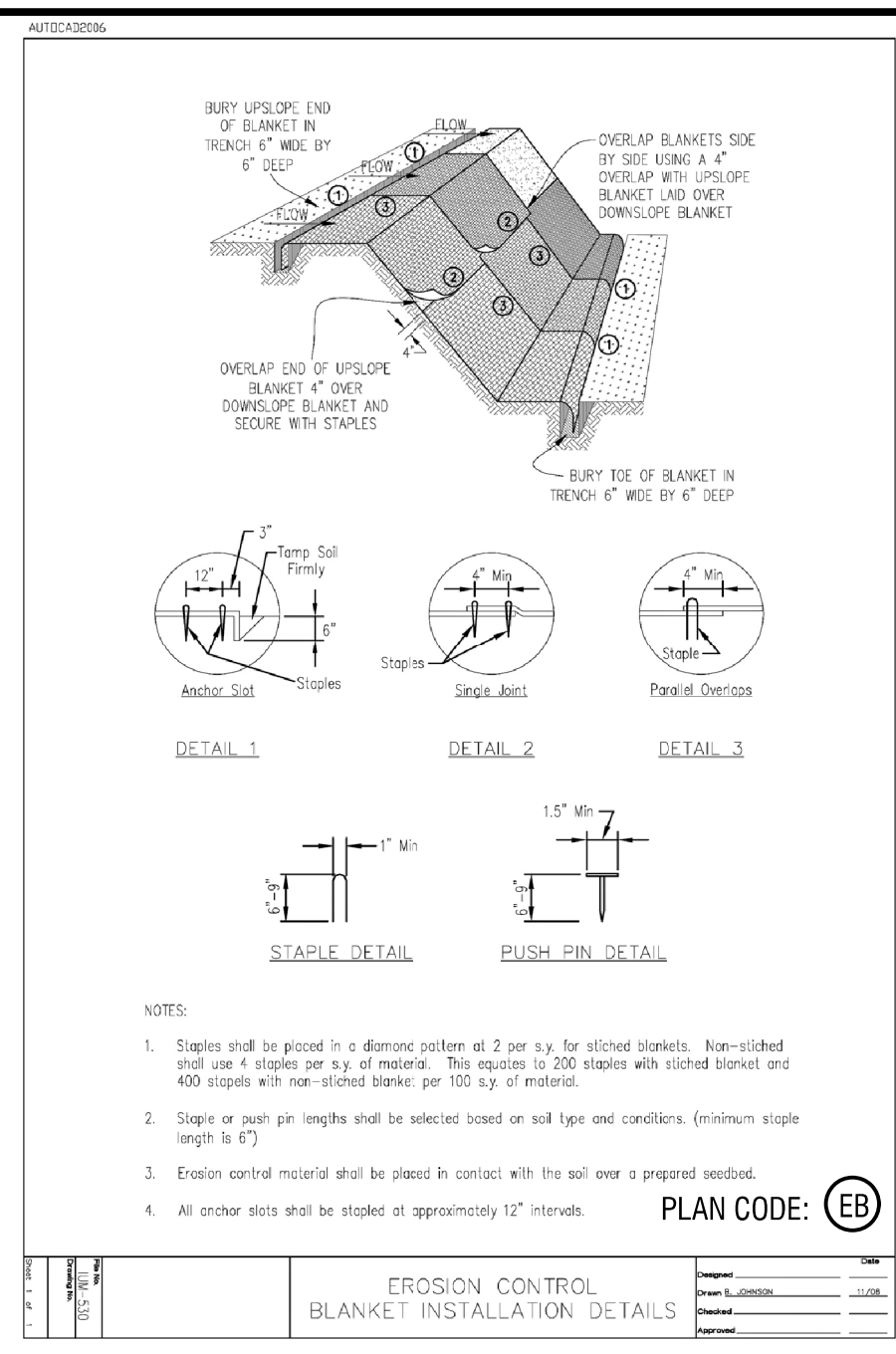

NO.	DATE	REMARKS

NO.	DATE	REMARKS

**SOIL EROSION AND SEDIMENT CONTROL PLAN - 2**

**ROSE CENTER LOCKPORT**

**LOT 1A - PANDA EXPRESS**

**LOCKPORT, ILLINOIS**

**CONSULTING ENGINEERS**

**SITE DEVELOPMENT ENGINEERS**

**LAND SURVEYORS**

224 1/2 N. Liberty Street,  
Morris, Illinois 60450

Phone: (615) 941-0260 Fax: (615) 941-0263



FILENAME: C8\_5225.03-SE2

DATE: 01/30/23

JOB NO. 5225.03-M

SHEET **SE2**

8 OF 11

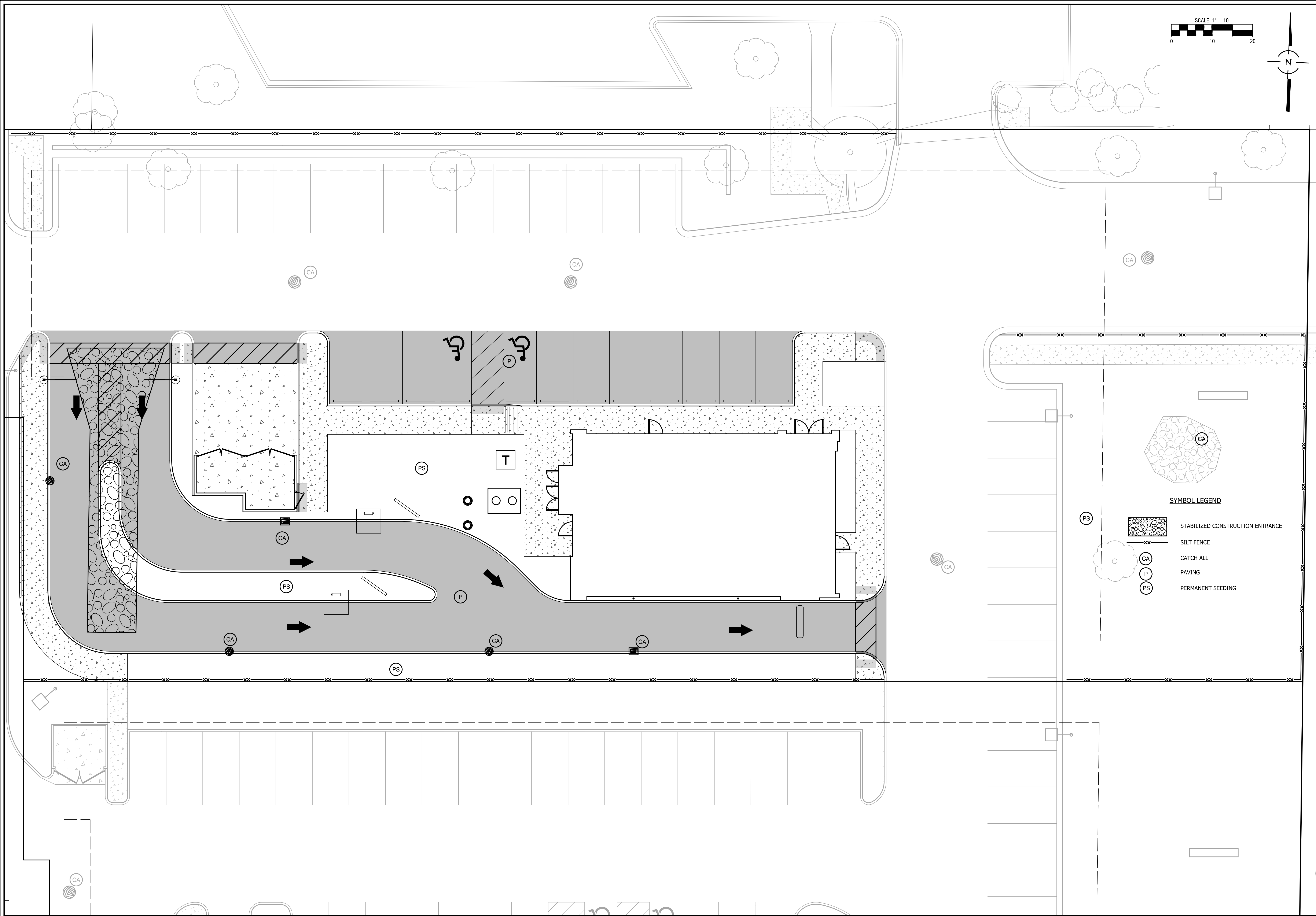

SCALE 1" = 10'

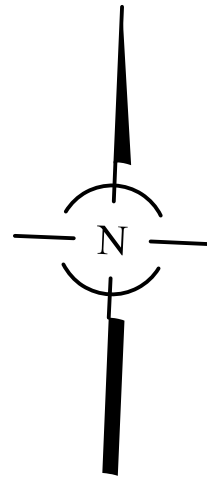

CA

CA

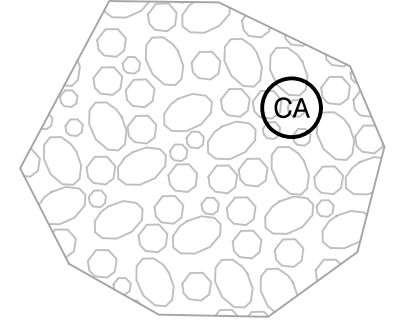

SYMBOL LEGEND



STABILIZED CONSTRUCTION ENTRANCE

XX SILT FENCE

CA CATCH ALL

P PAVING

PS PERMANENT SEEDING

NO.	DATE	REMARKS

NO.	DATE	REMARKS
1	3/6/23	PER CITY REVIEW
2	3/23/23	PER CITY REVIEW

**SOIL EROSION & SEDIMENT CONTROL PLAN - 3**  
**ROSE CENTER LOCKPORT**  
**LOT 1A - PANDA EXPRESS**  
 LOCKPORT, ILLINOIS

**CONSULTING ENGINEERS**  
**SITE DEVELOPMENT ENGINEERS**  
**LAND SURVEYORS**

224 1/2 N. Liberty Street,  
 Morris, Illinois 60450  
 Phone: (815) 941-0260 Fax: (815) 941-0263



FILENAME:  
 C9\_5225.03-SE3

DATE:  
 01/30/23

JOB NO.  
 5225.03-M

SHEET  
**SE3**  
 9 OF 11

EARTHWORK NOTES	PAVING NOTES	SANITARY SEWER NOTES	STORM SEWER NOTES
<p>1. GENERAL</p> <p>A. IT IS THE CONTRACTOR'S RESPONSIBILITY TO UNDERSTAND THE SOIL AND GROUNDWATER CONDITIONS AT THE SITE. THE CONTRACTOR SHALL OBTAIN AND READ THE GEOTECHNICAL REPORTS AVAILABLE FROM THE OWNER.</p> <p>B. ANY QUANTITIES IN THE BID PROPOSAL ARE INTENDED AS A GUIDE FOR THE CONTRACTOR'S USE IN DETERMINING THE SCOPE OF THE COMPLETED PROJECT. IT IS THE CONTRACTOR'S RESPONSIBILITY TO DETERMINE ALL MATERIAL QUANTITIES AND APPRAISE HIMSELF OF ALL SITE CONDITIONS. THE CONTRACT PRICE SUBMITTED BY THE CONTRACTOR SHALL BE CONSIDERED AS LUMP SUM FOR THE COMPLETE PROJECT. NO CLAIMS FOR EXTRA WORK WILL BE RECOGNIZED UNLESS ORDERED IN WRITING BY THE OWNER.</p> <p>C. THE CONTRACTOR WILL NOTE THAT THE ELEVATIONS SHOWN ON THE CONSTRUCTION PLANS ARE FINISHED GRADE ELEVATIONS AND THAT PAVEMENT THICKNESS, TOPSOIL, ETC. MUST BE SUBTRACTED TO DETERMINE SUBGRADE ELEVATIONS.</p> <p>D. THE CONTRACTOR SHALL MAINTAIN POSITIVE DRAINAGE DURING CONSTRUCTION, AND PREVENT STORMWATER FROM RUNNING INTO OR STANDING IN EXCAVATED AREAS. THE FAILURE TO PROVIDE PROPER DRAINAGE WILL NEGATE ANY POSSIBLE ADDED COMPENSATION REQUESTED DUE TO DELAYS OR UNSUITABLE MATERIALS CREATED AS A RESULT THEREOF. FINAL GRADES SHALL BE PROTECTED AGAINST DAMAGE FROM EROSION, SEDIMENTATION AND TRAFFIC.</p> <p>E. PLANS FOR THE SITE Dewatering, IF EMPLOYED, SHALL BE SUBMITTED TO AND APPROVED BY THE OWNER PRIOR TO IMPLEMENTATION. NO ADDITIONAL COMPENSATION SHALL BE MADE FOR Dewatering DURING CONSTRUCTION.</p> <p>F. THE CONTRACTOR SHALL BE RESPONSIBLE FOR IMPLEMENTATION OF THE "SOIL EROSION AND SEDIMENTATION CONTROL MEASURES". THE INITIAL ESTABLISHMENT OF EROSION CONTROL PROCEDURES AND THE PLACEMENT OF SILT AND FILTER FENCING, ETC. TO PROTECT ADJACENT PROPERTY, WETLANDS, ETC. SHALL OCCUR BEFORE GRADING BEGINS. A MUNICIPAL EROSION CONTROL INSPECTION MAY BE REQUIRED BEFORE ANY EARTHWORK IS PERFORMED.</p> <p>G. PRIOR TO COMMENCEMENT OF GRADING ACTIVITIES, THE CONTRACTOR SHALL ERRECT A "SNOW FENCE" AROUND ANY TREE DESIGNATED TO BE PRESERVED. SAID FENCE SHALL BE PLACED IN A CIRCLE CENTERED AROUND THE TREE. THE DIAMETER OF WHICH SHALL BE SUCH THAT THE ENTIRE DRIP ZONE (EXTENT OF FURTHEST EXTENDING BRANCHES) SHALL BE WITHIN THE FENCE LIMITS. THE EXISTING GRADE WITHIN THE FENCED AREA SHALL NOT BE DISTURBED.</p> <p>H. EXCESS MATERIALS, IF NOT UTILIZED AS FILL, SHALL BE COMPLETELY REMOVED FROM THE CONSTRUCTION SITE AND DISPOSED OF OFF-SITE BY THE CONTRACTOR.</p> <p>I. ALL EARTHWORK SHALL BE DONE UNDER THE SUPERVISION OF AN ILLINOIS LICENSED ENGINEER WHO SPECIALIZES IN THE GEOTECHNICAL FIELD (SOILS ENGINEER). THIS ENGINEER WILL BE RESPONSIBLE FOR ENSURING THAT ALL UNSUITABLE MATERIALS ARE REMOVED, ALL STRUCTURAL FILL MATERIALS ARE PROPERLY PLACED AND COMPACTED, ALL PAVEMENT SUBGRADES ARE PROPERLY PREPARED, PROOF ROLLING SUBGRADES, AND ENSURING THAT ALL WATER RETAINING EMBANKMENTS ARE PROPERLY CONSTRUCTED. THE DEVELOPER PAYS FOR ALL GEOTECHNICAL SERVICES.</p> <p>2. TOPSOIL EXCAVATION INCLUDES:</p> <p>A. EXCAVATION OF TOPSOIL AND OTHER STRUCTURALLY UNSUITABLE MATERIALS WITHIN THOSE AREAS THAT WILL REQUIRE EARTH EXCAVATION OR COMPACTED EARTH FILL MATERIAL. EXISTING VEGETATION SHALL BE REMOVED PRIOR TO STRIPPING TOPSOIL OR FILLING AREAS.</p> <p>B. PLACEMENT OF THE EXCAVATED MATERIAL IN OWNER DESIGNATED AREAS FOR FUTURE USE WITHIN AREAS TO BE LANDSCAPED, AND THOSE AREAS NOT REQUIRING STRUCTURAL FILL MATERIAL. PROVIDE NECESSARY EROSION CONTROL MEASURES FOR STOCKPILE.</p> <p>C. TOPSOIL STOCKPILED FOR RESPAED SHALL BE FREE OF CLAY AND SHALL NOT CONTAIN ANY OF THE TRANSITIONAL MATERIAL BETWEEN THE TOPSOIL AND CLAY. THE TRANSITIONAL MATERIAL SHALL BE USED IN NON-STRUCTURAL FILL AREAS OR DISPOSED OF OFF-SITE.</p> <p>D. TOPSOIL RESPAED SHALL INCLUDE HAULING AND SPREADING 6" OF TOPSOIL OVER AREAS TO BE LANDSCAPED WHERE SHOWN ON THE PLANS OR DIRECTED BY THE OWNER.</p> <p>E. MODERATE COMPACTION IS REQUIRED IN NON-STRUCTURAL FILL AREAS.</p> <p>3. EARTH EXCAVATION INCLUDES:</p> <p>A. EXCAVATION OF CLAY AND OTHER MATERIALS WHICH ARE SUITABLE FOR USE AS STRUCTURAL FILL. THE EXCAVATION SHALL BE TO WITHIN A TOLERANCE OF 0.1 FEET OF THE PLAN SUBGRADE ELEVATIONS WHILE MAINTAINING PROPER DRAINAGE. THE TOLERANCE WITHIN PAVEMENT AREAS SHALL BE SUCH THAT THE EARTH MATERIALS SHALL "BALANCE" DURING THE FINE GRADING OPERATION.</p> <p>B. PLACEMENT OF THE CLAY AND OTHER SUITABLE MATERIALS SHALL BE WITHIN THOSE AREAS REQUIRING STRUCTURAL FILL IN ORDER TO ACHIEVE THE PLAN SUBGRADE ELEVATIONS TO WITHIN A TOLERANCE OF 0.1 FEET. THE FILL MATERIAL SHALL BE PLACED IN LOOSE LISTS THAT SHALL NOT EXCEED EIGHT (8) INCHES IN THICKNESS, AND THE WATER CONTENT SHALL BE ADJUSTED IN ORDER TO ACHIEVE REQUIRED COMPACTION.</p> <p>C. STRUCTURAL FILL MATERIAL MAY BE PLACED WITHIN THOSE PORTIONS OF THE SITE NOT REQUIRING STRUCTURAL FILL, TO WITHIN SIX (6) INCHES OF THE PLAN FINISHED GRADE ELEVATION. IN AREAS REQUIRING STRUCTURAL FILL, HOWEVER, THIS MATERIAL SHALL NOT BE OTHER UNSUITABLE MATERIALS UNLESS SPECIFICALLY DIRECTED BY A SOILS ENGINEER WITH THE CONCURRENCE OF THE OWNER.</p> <p>D. COMPACTION OF THE CLAY AND OTHER SUITABLE MATERIALS, SHALL BE TO AT LEAST 93% OF THE MODIFIED PROCTOR DRY DENSITY WITHIN PROPOSED PAVEMENT AREAS, SIDEWALK, ETC. COMPACTION SHALL BE AT LEAST 95% OF THE MODIFIED PROCTOR WITHIN PROPOSED BUILDING PAD AREAS.</p> <p>E. EXCAVATION: QUANTITIES OF EARTH EXCAVATION INDICATED ELSEWHERE IN THIS CONTRACT HAVE BEEN COMPUTED BY THE END AREA METHOD AS PROVIDED FOR IN SECTION 202 OF THE STANDARD SPECIFICATIONS. EXCAVATED MATERIALS NOT NEEDED FOR THIS JOB SITE SHALL BE LEGALLY DISPOSED OF. PAYMENT SHALL BE MADE AT THE CONTRACT UNIT PRICE PER CUBIC YARD OF EARTH EXCAVATION.</p> <p>4. UNSUITABLE MATERIAL</p> <p>UNSUITABLE MATERIAL SHALL BE CONSIDERED AS MATERIAL WHICH IS NOT SUITABLE FOR THE SUPPORT OF PAVEMENT AND BUILDING CONSTRUCTION, AND IS ENCOUNTERED BELOW NORMAL TOPSOIL DEPTHS AND THE PROPOSED SUBGRADE ELEVATION. THE DECISION TO REMOVE SAID MATERIAL, AND TO WHAT EXTENT, SHALL BE MADE BY A SOILS ENGINEER WITH THE CONCURRENCE OF THE OWNER.</p> <p>5. MISCELLANEOUS THE CONTRACTOR SHALL:</p> <p>A. SPREAD AND COMPACT UNIFORMLY TO THE DEGREE SPECIFIED ALL EXCESS TRENCH SPOIL AFTER COMPLETION OF THE UNDERGROUND IMPROVEMENTS.</p> <p>B. SCARIFY, DISC, AERATE, AND COMPACT, TO THE DEGREE SPECIFIED, THE UPPER TWELVE (12) INCHES OF THE SUITABLE SUBGRADE MATERIAL IN ALL AREAS THAT MAY BE SOFT DUE TO EXCESS MOISTURE CONTENT. THIS APPLIES TO CUT AREAS AS WELL AS FILL AREAS.</p> <p>C. PROVIDE WATER TO ADD TO DRY MATERIAL IN ORDER TO ADJUST THE MOISTURE CONTENT FOR THE PURPOSE OF ACHIEVING THE SPECIFIED COMPACTION.</p> <p>D. BACKFILL THE CURB AND GUTTER AFTER ITS CONSTRUCTION AND PRIOR TO THE PLACEMENT OF THE BASE COURSE MATERIAL. THE CURBS SHALL NOT BE BACKFILLED UNTIL THE CONCRETE HAS CURED FOR AT LEAST 7 DAYS.</p> <p>E. TRENCH COMPACTION: ALL TRENCHES SHALL BE COMPACTED BY MECHANICAL TECHNIQUES APPROVED BY THE SOILS ENGINEER UNTIL PROPER COMPACTION IS ACHIEVED. THE REQUIREMENT FOR MECHANICAL COMPACTION MAY BE WAIVED IF, IN THE OPINION OF THE SOILS ENGINEER AND THE MUNICIPAL ENGINEER, THE EXCAVATED TRENCHES MEET THE DENSITY REQUIREMENTS. JETTING OF TRENCHES FOR COMPACTION WILL NOT BE ALLOWED.</p> <p>6. TESTING AND FINAL ACCEPTANCE</p> <p>A. THE CONTRACTOR SHALL PROVIDE AS A MINIMUM, A FULLY LOADED SIX-WHEEL TANDEM AXLE TRUCK FOR PROOF ROLLING TO TEST THE SUBGRADE PRIOR TO THE PLACEMENT OF THE CURB AND GUTTER AND THE BASE MATERIAL. THIS SHALL BE WITNESSED BY MUNICIPAL ENGINEER AND THE OWNER. SEE PAVING SPECIFICATION.</p> <p>B. ANY UNSUITABLE AREA ENCOUNTERED AS A RESULT OF PROOF ROLLING SHALL BE REMOVED AND REPLACED WITH SUITABLE MATERIAL, OR OTHERWISE CORRECTED, APPROVED BY THE SOILS CONSULTANT.</p> <p>C. ANY TESTING THAT IS REQUIRED OF THIS CONSTRUCTION IS CONSIDERED INCIDENTAL TO THE COST OF CONSTRUCTION. NO SEPARATE PAYMENT WILL BE MADE.</p>	<p>1. GENERAL</p> <p>A. PAVING WORK INCLUDES FINAL SUBGRADE SHAPING, PREPARATION AND COMPACTION; PLACEMENT OF SUB-BASE OR BASE COURSE MATERIALS; FINISHING AND CURING OF THE SURFACE COURSE; FINISHING AND CURING CONCRETE PAVEMENT, CURBS AND WALKS; AND FINAL CLEAN-UP AND ALL RELATED WORK.</p> <p>B. COMPACTION REQUIREMENTS: REFERENCE ASTM D-1557 (MODIFIED PROCTOR) SUB-GRADE = 93%; SUB-BASE = 93%; AGGREGATE BASE COURSE = 95%; BITUMINOUS COURSES = REFER TO SSSRC ARTICLE 406.07. THE SOILS ENGINEER IS RESPONSIBLE FOR ENSURING THAT MATERIALS ARE PROPERLY PLACED AND COMPACTED.</p> <p>C. IT SHALL BE THE CONTRACTOR'S SOLE RESPONSIBILITY TO PROVIDE PROPER BARRICADING, WARNING DEVICES AND THE SAFE MANAGEMENT OF TRAFFIC WITHIN THE AREA OF CONSTRUCTION. ALL SUCH DEVICES AND THEIR INSTALLATION SHALL CONFORM TO THE ILLINOIS MANUAL OF UNIFORM TRAFFIC CONTROL, DEVICES, LATEST EDITION AND IN ACCORDANCE WITH THE MUNICIPAL CODE.</p> <p>2. SUB-GRADE PREPARATION</p> <p>A. EARTHWORK FOR PROPOSED PAVEMENT SUBGRADE SHALL BE FINISHED TO WITHIN 0.1 FOOT PLUS OR MINUS, OF PLAN ELEVATION. THE CONTRACTOR SHALL SATISFY HIMSELF THAT THE SUBGRADE HAS BEEN PROPERLY PREPARED AND THAT THE FINISH TOP SUBGRADE ELEVATION HAS BEEN GRADDED WITH TOLERANCES ALLOWED IN THESE SPECIFICATIONS. UNLESS THE CONTRACTOR ADVISES THE OWNER AND ENGINEER IN WRITING PRIOR TO FINE GRADING FOR BASE COURSE CONSTRUCTION, IT IS UNDERSTOOD THAT HE HAS APPROVED AND ACCEPTS THE RESPONSIBILITY FOR THE SUBGRADE.</p> <p>B. PRIOR TO THE PLACEMENT OF THE BASE COURSE, THE SUBGRADE MUST BE PROOF ROLLED AND INSPECTED FOR UNSUITABLE MATERIALS AND/OR EXCESSIVE MOVEMENT. THE SOILS ENGINEER SHALL CONDUCT AND THE VILLAGE SHALL WITNESS ALL PROOF ROLLS. IF UNSUITABLE SUBGRADE IS ENCOUNTERED, IT SHALL BE CORRECTED IN A MANNER APPROVED BY THE OWNER OR HIS REPRESENTATIVE. THIS MAY INCLUDE ONE OR MORE OF THE FOLLOWING METHODS:</p> <ol style="list-style-type: none"> <li>1) SCARIFY DISC AND AERATE.</li> <li>2) REMOVE AND REPLACE WITH STRUCTURAL CLAY FILL.</li> <li>3) REMOVE AND REPLACE WITH GRANULAR MATERIAL.</li> <li>4) USE OF GEOTEXTILE FABRIC.</li> </ol> <p>MAXIMUM DEFLECTION ALLOWED IN ISOLATED AREAS MAY BE 1/4" TO 1/2" IF NO DEFLECTION OCCURS OVER THE MAJORITY OF THE AREA.</p> <p>C. PRIOR TO THE CONSTRUCTION OF THE CURB AND GUTTER AND THE PLACEMENT OF THE BASE MATERIAL, THE PAVEMENT AREA SHALL BE FINE GRADED TO WITHIN 0.04 FEET (1/2") OF FINAL SUBGRADE ELEVATION, TO A POINT TWO (2) FEET BEYOND THE BACK OF CURB, SO AS TO INSURE THE PROPER THICKNESS OF PAVEMENT COURSES. NO CLAIMS FOR EXCESS QUANTITY OF BASE MATERIALS DUE TO IMPROPER SUBGRADE PREPARATION WILL BE HONORED.</p> <p>D. PRIOR TO PLACEMENT OF THE BASE COURSE, ALL SUBGRADES MUST BE APPROVED BY THE MUNICIPAL ENGINEER, SOILS ENGINEER AND/OR OWNER.</p> <p>3. CONCRETE WORK</p> <p>A. ALL EXTERIOR CONCRETE SHALL BE PORTLAND CEMENT CONCRETE CLASS 91 OR PV PER (SSRBC) SECTION 1020.04 WITH AIR ENTRAINMENT OF NOT LESS THAN FIVE (5%) OR MORE THAN EIGHT (8%) PERCENT. CONCRETE SHALL BE A MINIMUM OF SIX (6) BAG MIX AND SHALL DEVELOP A MINIMUM OF 3,500 PSI COMPRESSIVE STRENGTH AT FOURTEEN (14) DAYS. ALL CONCRETE SHALL BE BRODCH FINISHED PERPENDICULAR TO THE DIRECTION OF TRAVEL. THE ADDITION OF CALCIUM CHLORIDE AND THE SUBSTITUTION OF FLY ASH FOR PORTLAND CEMENT IS PROHIBITED. 1.50 lbs of COLLATED, FILLBRATED, POLYPROPYLENE OLEFIN FIBERS 0.50 TO 0.75 INCHES IN LENGTH SHALL BE ADDED TO EACH CUBIC YARD OF CONCRETE USED FOR SIDEWALKS. THE FIBERS SHALL BE AS MANUFACTURED UNDER THE NAME "FIBERMESH" OR EQUAL.</p> <p>B. CONCRETE CURB AND/OR COMBINATION CURB AND GUTTER SHALL BE OF THE TYPE SHOWN ON THE PLANS. THE CONTRACTOR IS CAUTIONED TO REFER TO THE CONSTRUCTION STANDARDS AND THE PAVEMENT CROSS-SECTION TO DETERMINE THE GUTTER AND THE AGGREGATE BASE COURSE THICKNESS BENEATH THE CURB AND GUTTER. PREMOLDED FIBER EXPANSION JOINTS, WITH TWO 3/4" X 1/8" EPOXY COATED STEEL DOVEL BARS, SHALL BE INSTALLED AT SIXTY (60) FOOT INTERVALS AND AT ALL PCS, PTS AND CURB RETURNS. ALTERNATE ENDS OF THE DOVEL BARS SHALL BE GREASED AND FITTED WITH METAL EXPANSION TUBES. SAWED OR FORMED CONSTRUCTION JOINTS SHALL BE PROVIDED AT NO GREATER THAN FIFTEEN (15) FOOT INTERVALS BETWEEN EXPANSION JOINTS AND CAULKED. NO HONEY-COMBING OF THE CURB AND GUTTER WILL BE ACCEPTED.</p> <p>C. CURBS SHALL BE DEPRESSED AT LOCATIONS WHERE PUBLIC WALKS/PEDESTRIAN PATHS INTERSECT CURB LINES, AND OTHER LOCATIONS AS DIRECTED, FOR THE PURPOSE OF PROVIDING ACCESSIBILITY. (SEE CONSTRUCTION STANDARDS FOR DETAIL). BARRIER CURB SHALL ALSO BE DEPRESSED AT DRIVEWAY LOCATIONS.</p> <p>D. THE CURBS SHALL BE BACKFILLED AFTER THEIR CONSTRUCTION AND PRIOR TO THE PLACEMENT OF THE BASE COURSE. THE CONCRETE MUST CURE FOR AT LEAST SEVEN DAYS BEFORE THE CURBS ARE BACKFILLED.</p> <p>E. CONCRETE SIDEWALK SHALL BE IN ACCORDANCE WITH THE ABOVE AND THE PLANS. PROVIDE SCORED JOINTS AT 5 FOOT INTERVALS AND 1/2" PREMOLDED FIBER EXPANSION JOINTS AT 50 FOOT INTERVALS, AND ADJACENT TO CONCRETE CURBS, DRIVEWAYS, FOUNDATIONS, ETC.</p> <p>F. CONCRETE DRIVEWAY APRONS SHALL BE IN ACCORDANCE WITH THE ABOVE AND THE PLANS. PROVIDE 6" X 6" NO. 6 WELDED WIRE MESH 12" FINISHED GRADE ELEVATION. THE ADJACENT TO CURBS AND CONCRETE SIDEWALKS. PROVIDE SAWED OR FORMED CONTRACTION JOINT AT MID-POINT AND 15 FOOT MAXIMUM.</p> <p>G. STANDARD REINFORCED CONCRETE PAVEMENT SHALL BE IN ACCORDANCE WITH THE ABOVE AND THE PLANS. SAWED OR FORMED CONTRACTION EXPANSION JOINTS SHALL BE AS SHOWN ON THE PLANS.</p> <p>H. CONCRETE CURING AND PROTECTION SHALL BE IN ACCORDANCE WITH (SSRBC) -METHOD I, II, OR III.</p> <p>I. THE COST OF AGGREGATE BASE OR SUB-BASE UNDER CONCRETE WORK SHALL BE INCLUDED IN THE COST OF THE RESPECTIVE CONCRETE ITEM.</p> <p>4. FLEMBLE PAVEMENT</p> <p>A. THE PAVEMENT MATERIALS FOR BITUMINOUS STREETS, PARKING LOTS, DRIVEWAYS, SIDEWALKS AND PATHS SHALL BE AS DETAILED ON THE PLANS. UNLESS OTHERWISE SHOWN ON THE PLANS, THE FLEXIBLE PAVEMENTS SHALL CONSIST OF AGGREGATE BASE COURSE (I, II, 19.0, NS); BITUMINOUS CONCRETE BINDER COURSE; AND BITUMINOUS CONCRETE SURFACE COURSE. MIX "D" NS; OF THE THICKNESS AND MATERIALS SPECIFIED ON THE PLANS. THICKNESSES SPECIFIED SHALL BE CONSIDERED TO BE THE MINIMUM COMPACTED THICKNESS. THE PAVING IS TO BE DONE IN ACCORD WITH THE STANDARD SPECIFICATIONS FOR ROAD AND BRIDGE CONSTRUCTION IN ILLINOIS.</p> <p>B. ALL TRAFFIC SHALL BE KEPT OFF THE COMPLETED AGGREGATE BASE UNTIL THE BINDER COURSE IS LAID. THE AGGREGATE BASE SHALL BE UNIFORMLY PRIME COATED AT A RATE OF 0.4 TO 0.5 GALLONS PER SQUARE YARD PRIOR TO PLACING THE BINDER COURSE. PRIME COAT MATERIALS SHALL BE BITUMINOUS M.C. -30.</p> <p>C. PRIOR TO PLACEMENT OF THE SURFACE COURSE, THE BINDER COURSE SHALL BE CLEANED, AND TACK COATED IF DUSTY OR DIRTY OR THE TIME BETWEEN LEFTS EXCEEDS 30 DAYS. ALL DAMAGED AREAS IN THE BINDER, BASE OR CURB SHALL BE REPAIRED TO THE SATISFACTION OF THE OWNER PRIOR TO LAYING THE SURFACE COURSE. THE CONTRACTOR SHALL PROVIDE WHATEVER EQUIPMENT AND MANPOWER NECESSARY, INCLUDING THE USE OF POWER BROOMS IF REQUIRED BY THE OWNER, TO PREPARE THE PAVEMENT FOR APPLICATION OF THE SURFACE COURSE. THE TACK COAT SHALL BE UNIFORMLY APPLIED TO THE BINDER COURSE AT A RATE OF 0.35 TO 0.10 GALLONS PER SQUARE YARD. TACK COAT SHALL BE AS SPECIFIED IN (SSRBC) SECTION 406.02.</p> <p>D. SEAMS IN BASE, BINDER AND SURFACE COURSE SHALL BE STAGGERED A MINIMUM OF 6'.</p> <p>E. FOR NEW STREETS, THE CONTRACTOR SHALL PERMIT THE BITUMINOUS CONCRETE BINDER COURSE TO WEATHER ONE (1) WINTER SEASON PRIOR TO THE INSTALLATION OF THE BITUMINOUS CONCRETE SURFACE COURSE UNLESS OTHERWISE SPECIFIED BY THE MUNICIPAL ENGINEER OR OWNER.</p> <p>5. TESTING AND FINAL ACCEPTANCE</p> <p>A. THE CONTRACTOR SHALL FOLLOW THE QUALITY CONTROL TESTING PROGRAM FOR CONCRETE AND PAVEMENT MATERIALS ESTABLISHED BY THE OWNER AND/OR MUNICIPALITY. TESTING SHALL BE DONE IN ACCORD WITH THE STANDARD SPECIFICATIONS FOR ROAD AND BRIDGE CONSTRUCTION IN ILLINOIS AND THE TESTING REQUIREMENTS OF THE MUNICIPALITY.</p> <p>B. WHEN REQUESTED BY THE OWNER, TEST RESULTS AND DOCUMENTATION FOR THE CONCRETE, BASE COURSE, BITUMINOUS CONCRETE BINDER, AND/OR SURFACE COURSE, SHALL BE SUBMITTED FOR VERIFICATION.</p> <p>C. PRIOR TO PLACEMENT OF THE BITUMINOUS CONCRETE SURFACE COURSE, THE CONTRACTOR, WHEN REQUIRED BY THE OWNER OR MUNICIPALITY, SHALL OBTAIN SPECIMENS OF THE BINDER COURSE WITH A CORE DRILL WHERE DIRECTED, FOR THE PURPOSE OF THICKNESS VERIFICATION.</p> <p>D. WHEN REQUIRED BY THE OWNER OR MUNICIPALITY, THE CONTRACTOR SHALL OBTAIN SPECIMENS OF THE FULL DEPTH BITUMINOUS CONCRETE PAVEMENT STRUCTURE WITH A CORE DRILL WHERE DIRECTED, IN ORDER TO CONFIRM THE PLAN THICKNESS. DEFICIENCIES IN THICKNESS SHALL BE ADJUSTED FOR BY THE METHOD DESCRIBED IN (SSRBC), ART. 407.10.</p> <p>E. FINAL ACCEPTANCE OF THE TOTAL PAVEMENT INSTALLATION SHALL BE SUBJECT TO THE TESTING AND CHECKING REQUIREMENTS CITED ABOVE.</p>	<p>1. GENERAL</p> <p>A. SANITARY SEWER PIPE SHALL BE PVC (POLYVINYL CHLORIDE) PLASTIC PIPE WITH A STANDARD DIMENSION RATIO (SDR) OF 38 CONFORMING TO ASTM D-3024 WITH PUSH-ON JOINTS CONFORMING TO ASTM D-3212 AND PVC (POLYVINYL CHLORIDE) PLASTIC PIPE WITH A STANDARD DIMENSION RATIO (SDR) OF 21 CONFORMING TO ASTM D-2241 WITH PUSH-ON JOINTS CONFORMING TO ASTM D-1319 AS SHOWN ON THE PLANS. PAYMENT SHALL BE MADE AT THE CONTRACT UNIT PRICE PER LINEAL FOOT OF SANITARY SEWER COMPLETE IN PLACE.</p> <p>B. SANITARY SEWER PIPE 18" AND LARGER, WHERE NOTED ON THE PLANS, OR WHERE THE IEPA MINIMUM SEPARATION CANNOT BE MAINTAINED, SHALL BE ONE OF THE FOLLOWING:</p> <p>PLAN CODE DESCRIPTION</p> <p>DIP: DUCTILE IRON WATERMAIN QUALITY PIPE, CLASS 52, (ANSI A-21.51) WITH MECHANICAL OR O-RING GASKETED JOINTS (ANSI A-21.11).</p> <p>PVC: PRESSURE RATED PVC PIPE MEETING ASTM D-2241 WITH ASTM D-319 GASKETED JOINT, SDR 28</p> <p>C. "BAND-SEAL" OR SIMILAR FLEXIBLE TYPE COUPLINGS SHALL BE USED WHEN CONNECTING SEWER PIPES OF DISSIMILAR MATERIALS. "BAND-SEAL", "FERNOCO", AND "MISSION" TYPE COUPLINGS SHALL NOT BE USED ON ANY SEWER MAIN.</p> <p>D. ALL SANITARY SEWERS ARE TO BE CONSTRUCTED USING A LASER INSTRUMENT TO MAINTAIN LINE AND GRADE.</p> <p>E. ALL FLOOR DRAINS SHALL CONNECT TO THE SANITARY SEWER.</p> <p>F. CONNECTIONS TO EXISTING SANITARY SEWER SYSTEM SHALL NOT BE DONE UNTL AUTHORIZED BY THE MUNICIPALITY.</p> <p>G. WATERMANS SHALL BE SEPARATED FROM SANITARY SEWERS AND STORM SEWERS IN ACCORDANCE WITH IEPA REQUIREMENTS AS SPECIFIED IN "WATER MAIN" SECTION.</p> <p>H. NO WATER LINE SHALL BE PLACED IN THE SAME TRENCH AS A SEWER LINE EXCEPT UNDER SPECIAL CIRCUMSTANCES AND THEN ONLY UNDER THE FOLLOWING RULES:</p> <ol style="list-style-type: none"> <li>a) PERMISSION SHALL BE OBTAINED FROM THE MUNICIPAL ENGINEERING DEPARTMENT IN WRITING PRIOR TO BEGINNING CONSTRUCTION.</li> <li>b) THE BOTTOM OF A WATER LINE SHALL BE INSTALLED ON A SHELF A MINIMUM OF 18" ABOVE THE TOP OF THE SEWER AND 18" HORIZONTALLY AWAY FROM THE EDGE OF THE SEWER.</li> </ol> <p>2. BEDDING:</p> <p>A. BEDDING SHALL CONSIST OF A MINIMUM OF FOUR (4") INCHES OF COMPACTED CRUSHED GRAVEL OR STONE, 1/4" - 3/4" IN SIZE. THE SEWER SHALL HAVE MECHANICALLY TAMPED CRUSHED GRAVEL OR STONE COVER ABOVE THE TOP OF THE PIPE TO A MINIMUM OF TWELVE (12") INCHES FOR PVC PIPE AND TO THE SPRING LINE FOR DIP. THE BEDDING AND COVER MATERIAL SHALL BE ASTM D-2321 CLASS II FOR PVC PIPE AND ASTM D-445 SIZE #1 FOR DIP PIPE. THE COST OF THE BEDDING AND COVER SHALL BE MERGED WITH THE UNIT PRICE BID FOR THE SEWER.</p> <p>B. ALL UNSUITABLE MATERIAL SHALL BE REMOVED BELOW THE PROPOSED SANITARY SEWER AND REPLACED WITH COMPACTED CA-7 CRUSHED GRAVEL OR STONE.</p> <p>C. ALL TRENCHES BENEATH PROPOSED OR EXISTING UTILITIES, PAVEMENTS, ROADWAYS, SIDEWALKS, AND FOR A DISTANCE OF FIVE (5) FEET ON EITHER SIDE OF SAME, AND/OR WHERE SHOWN ON THE PLANS, SHALL BE BACKFILLED WITH SELECT GRANULAR BACKFILL (CA-7) AND THOROUGHLY MECHANICALLY COMPACTED IN 8" THICK LAYERS (MEASUREMENT) LAYERS. JETTING WITH WATER IS NOT PERMITTED. REFER TO THE TRENCH BACKFILL LIMITS DETAIL.</p> <p>3. MANHOLES:</p> <p>A. SANITARY SEWER MANHOLES SHALL BE 4'-0" I.D. PRECAST CONCRETE SECTIONS CONFORMING TO ASTM D-478 WITH PREFORMED BITUMINOUS OR "O" RING JOINTS, IN ACCORDANCE WITH MUNICIPAL REGULATIONS, AND HAVE AN ECCENTRIC CONE INSTALLED TO LINE UP WITH THE MANHOLE STEPS. ALL MANHOLE STEPS SHALL BE AT 16" O.C. SIMILAR TO NEENAH R-1990.</p> <p>B. ALL PIPE CONNECTION OPENINGS SHALL BE PRECAST WITH RESILIENT RUBBER WATER TIGHT SLEEVES. THE BOTTOM OF MANHOLE SHALL HAVE A CONCRETE BENCH POURS TO FACILITATE SMOOTH FLOWS.</p> <p>4. FRAMES AND LIDS:</p> <p>A. ALL SANITARY SEWER MANHOLE FRAMES AND LIDS SHALL BE NEENAH R-1712 UNLESS OTHERWISE NOTED ON THE PLANS. THE LIDS SHALL HAVE RECESSED (CONCEALED) PICK HOLE AND BE SELF SEALING WITH AN "O" RING GASKET. THE LIDS SHALL HAVE THE WORDS "SANITARY" EMBOSSED ON THE SURFACE. THE JOINTS BETWEEN FRAME AND CONCRETE SECTION SHALL BE SEALED WITH A BUTYL ROPE.</p> <p>B. A MAXIMUM OF EIGHT (8) INCHES OF CONCRETE ADJUSTING RINGS SHALL BE USED TO ADJUST FRAME ELEVATIONS. RINGS SHALL BE SEALED TOGETHER WITH BUTYL ROPE.</p> <p>5. DROP MANHOLE ASSEMBLIES:</p> <p>A. DROP MANHOLE ASSEMBLIES: DROP MANHOLE ASSEMBLIES SHALL BE PROVIDED AT THE JUNCTION OF SANITARY SEWERS WHERE THE DIFFERENCE IN INVERT GRADES EXCEEDS TWO FEET (2'), OR AS SHOWN ON THE PLANS. THE ENTIRE DROP ASSEMBLY SHALL BE CAST IN CONCRETE MONOLITHICALLY WITH THE MANHOLE BARREL SECTION.</p> <p>6. CLEANING:</p> <p>A. ALL MANHOLES AND PIPES SHALL BE THOROUGHLY CLEANED OF DIRT AND DEBRIS, AND ALL VISIBLE LEAKAGE ELIMINATED, BEFORE FINAL INSPECTION AND ACCEPTANCE.</p> <p>7. TESTING:</p> <p>A. DEFLECTION AND LEAKAGE TESTING WILL BE REQUIRED. THE PROCEDURE AND ALLOWABLE TESTING LIMITS SHALL BE AS SPECIFIED IN THE "STANDARD SPECIFICATIONS FOR WATER AND SEWER MAIN CONSTRUCTION IN ILLINOIS" OR MUNICIPAL CODES. IN THE EVENT OF A DISCREPANCY BETWEEN THE STANDARD SPECIFICATIONS AND THE MUNICIPAL CODE, THE MUNICIPAL CODE SHALL GOVERN. THE FULL LENGTH OF THE SANITARY SEWER IS REQUIRED TO BE BOTH AIR TESTED AND DEFLECTION TESTED.</p> <p>B. TESTING THE ALIGNMENT/STRAIGHTNESS SHALL BE IN ACCORDANCE WITH MUNICIPAL CODE.</p> <p>C. TESTING OF MANHOLES TO BE IN ACCORDANCE WITH ASTM C-969.</p> <p>8. TELEVISIONING:</p> <p>A. ALL SANITARY SEWERS SHALL BE TELEVIEWED AND A COPY OF THE TAPE /DVD AND A WRITTEN REPORT SHALL BE SUBMITTED AND REVIEWED BY THE OWNER OR MUNICIPALITY BEFORE FINAL ACCEPTANCE. THE REPORT SHALL INCLUDE STUB LOCATION AS WELL AS A DESCRIPTION OF ALL DEFECTS, WATER LEVEL, LEAKS AND LENGTHS. IDENTIFY MANHOLE TO MANHOLE BOTH VERBALLY AND ON-SCREEN USING MANHOLE NUMBERS FROM APPROVED PLANS. ORDER OF WRITTEN REPORT SHALL BE THE SAME AS THE VIDEO TAPES/DVDS.</p> <p>9. TEST RESULTS:</p> <p>A. IF THE SANITARY SEWER INSTALLATION FAILS TO MEET THE TEST REQUIREMENTS SPECIFIED, THE CONTRACTOR SHALL DETERMINE THE CAUSE OR CAUSES OF THE DEFECT AND SHALL, AT HIS OWN EXPENSE, REPAIR OR REPLACE ALL MATERIALS, AND WORKSMANSHIP AS MAY BE NECESSARY TO CORRECT WITH THE TEST REQUIREMENTS.</p> <p>10. CERTIFICATION:</p> <p>A. CONTRACTOR SHALL SUBMIT CERTIFIED COPIES OF ALL REPORTS OF TESTS CONDUCTED BY AN INDEPENDENT LABORATORY BEFORE INSTALLATION OF PVC PLASTIC PIPE. TESTS SHALL BE CONDUCTED IN ACCORDANCE WITH STANDARD METHOD OF TEST FOR "EXTERNAL LOADING PROPERTIES OF PLASTIC PIPE BY PARALLEL PLATE LOADING". ASTM STANDARDS D-2412 OR D-2241 AS APPROPRIATE FOR THE PIPE TO BE USED. TESTS SHALL ALSO BE CONDUCTED TO DEMONSTRATE JOINT PERFORMANCE AT 5% MAXIMUM DIAMETRIC DEFLECTION OF THE SPIGOT.</p> <p>11. RECORD DRAWINGS:</p> <p>A. THE CONTRACTOR SHALL PROVIDE ALL INFORMATION TO PREPARE RECORD DRAWINGS (S) INCLUDING SERVICE STUB LOCATIONS TO SPACECO. SPACECO SHALL PREPARE RECORD DRAWINGS AND SUBMIT TO APPROPRIATE PUBLIC AGENCIES. IF FINAL MEASUREMENTS INDICATE DEFICIENCIES, THE CONTRACTOR, AT HIS OWN COST, WILL ADJUST MANHOLES AND/OR SEWERS TO PROPER ELEVATIONS AND OTHERWISE CORRECT THE DEFICIENCIES.</p>	<p>2. BEDDING:</p> <p>A. ALL STORM SEWERS SHALL BE INSTALLED ON A TYPE A GRANULAR BEDDING, 1/4" TO 3/4" IN SIZE (CA-7) WITH A MINIMUM THICKNESS EQUAL TO 1/4 THE OUTSIDE DIAMETER OF THE SEWER PIPE BUT NOT LESS THAN 4". BLOCKING OF ANY KIND FOR GRADE IS NOT PERMITTED. THE BEDDING MATERIALS SHALL BE COMPACTED TO 90% OF MODIFIED PROCTOR DENSITY. BEDDING SHALL EXTEND TO THE SPRINGLINE ON ALL RCP AND DIP PIPE. BEDDING SHALL EXTEND TO 12" OVER AN PVC OR HDPE PIPE. COST OF BEDDING SHALL BE CONSIDERED INCIDENTAL TO THE COST OF PIPE. NO SEPARATE PAYMENT SHALL BE MADE FOR THIS.</p> <p>3. STRUCTURES:</p> <p>A. MANHOLE, CATCH BASIN AND INLET BOTTOMS SHALL BE PRECAST CONCRETE SECTIONAL UNITS OR MONOLITHIC CONCRETE. MANHOLES AND CATCH BASINS SHALL BE A MINIMUM 4" IN DIAMETER UNLESS OTHERWISE SPECIFIED ON THE PLANS. STRUCTURE JOINTS SHALL BE SEALED WITH O-RING OR BUTYL ROPE. A MAXIMUM OF EIGHT (8") INCHES OF ADJUSTING RINGS SHALL BE USED.</p> <p>B. A CONCRETE BENCH TO DIRECT FLOWS SHALL BE CONSTRUCTED IN THE BOTTOM OF ALL INLETS AND MANHOLES.</p> <p>C. THE FRAME, GRATE, AND/OR CLOSED LID SHALL BE CAST IRON OF THE STYLE SHOWN ON THE PLANS.</p> <p>D. MANHOLE LIDS SHALL BE MACHINE SURFACED, NON-ROCKING DESIGN. THE CLOSED LIDS SHALL HAVE THE WORD "STORM" CAST ON THE LID. THE JOINTS BETWEEN CONCRETE SECTION ADJUSTING RINGS, AND FRAME SHALL BE SEALED WITH A MASTIC COMPOUND.</p> <p>4. FRENCH DRAIN:</p> <p>A. ALL LOW POINT STORM STRUCTURES ARE TO HAVE FOUR 1" DIAMETER WEEP HOLES PROVIDED 24" BELOW THE TOP OF LID. THE HOLES SHALL BE COVERED WITH A GEOTEXTILE FILTER FABRIC CEMENTED IN PLACE WITH BITUMINOUS MASTIC. THE DRAIN SHALL BE BACKFILLED WITH BEDDING OR CA-7 CRUSHED STONE TO TOP OF SUBGRADE OR BOTTOM OF TOPSOIL.</p> <p>5. CASTINGS:</p> <p>A. CASTINGS FOR SEWER OR OTHER STRUCTURES SHALL BE "NEENAH" OR APPROVED EQUAL. COST OF CASTINGS SHALL BE CONSIDERED INCIDENTAL TO THE COST OF THE STRUCTURE. NO SEPARATE PAYMENT SHALL BE MADE FOR THIS ITEM.</p> <p>6. CLEANING:</p> <p>A. THE STORM SEWER SYSTEM SHALL BE THOROUGHLY CLEANED PRIOR TO FINAL INSPECTION AND TESTING.</p> <p>7. TELEVISIONING:</p> <p>A. THE STORM SEWER SYSTEM SHALL BE TELEVIEWED IF REQUIRED BY MUNICIPALITY.</p>
<p>1. GENERAL</p> <p>A. EXCAVATION OF TOPSOIL AND OTHER STRUCTURALLY UNSUITABLE MATERIALS WITHIN THOSE AREAS THAT WILL REQUIRE EARTH EXCAVATION OR COMPACTED EARTH FILL MATERIAL. EXISTING VEGETATION SHALL BE REMOVED PRIOR TO STRIPPING TOPSOIL OR FILLING AREAS.</p> <p>B. PLACEMENT OF THE EXCAVATED MATERIAL IN OWNER DESIGNATED AREAS FOR FUTURE USE WITHIN AREAS TO BE LANDSCAPED, AND THOSE AREAS NOT REQUIRING STRUCTURAL FILL MATERIAL. PROVIDE NECESSARY EROSION CONTROL MEASURES FOR STOCKPILE.</p> <p>C. TOPSOIL STOCKPILED FOR RESPAED SHALL BE FREE OF CLAY AND SHALL NOT CONTAIN ANY OF THE TRANSITIONAL MATERIAL BETWEEN THE TOPSOIL AND CLAY. THE TRANSITIONAL MATERIAL SHALL BE USED IN NON-STRUCTURAL FILL AREAS OR DISPOSED OF OFF-SITE.</p> <p>D. TOPSOIL RESPAED SHALL INCLUDE HAULING AND SPREADING 6" OF TOPSOIL OVER AREAS TO BE LANDSCAPED WHERE SHOWN ON THE PLANS OR DIRECTED BY THE OWNER.</p> <p>E. MODERATE COMPACTION IS REQUIRED IN NON-STRUCTURAL FILL AREAS.</p> <p>3. EARTH EXCAVATION INCLUDES:</p> <p>A. EXCAVATION OF CLAY AND OTHER MATERIALS WHICH ARE SUITABLE FOR USE AS STRUCTURAL FILL. THE EXCAVATION SHALL BE TO WITHIN A TOLERANCE OF 0.1 FEET OF THE PLAN SUBGRADE ELEVATIONS WHILE MAINTAINING PROPER DRAINAGE. THE TOLERANCE WITHIN PAVEMENT AREAS SHALL BE SUCH THAT THE EARTH MATERIALS SHALL "BALANCE" DURING THE FINE GRADING OPERATION.</p> <p>B. PLACEMENT OF THE CLAY AND OTHER SUITABLE MATERIALS SHALL BE WITHIN THOSE AREAS REQUIRING STRUCTURAL FILL IN ORDER TO ACHIEVE THE PLAN SUBGRADE ELEVATIONS TO WITHIN A TOLERANCE OF 0.1 FEET. THE FILL MATERIAL SHALL BE PLACED IN LOOSE LISTS THAT SHALL NOT EXCEED EIGHT (8) INCHES IN THICKNESS, AND THE WATER CONTENT SHALL BE ADJUSTED IN ORDER TO ACHIEVE REQUIRED COMPACTION.</p> <p>C. STRUCTURAL FILL MATERIAL MAY BE PLACED WITHIN THOSE PORTIONS OF THE SITE NOT REQUIRING STRUCTURAL FILL, TO WITHIN SIX (6) INCHES OF THE PLAN FINISHED GRADE ELEVATION. IN AREAS REQUIRING STRUCTURAL FILL, HOWEVER, THIS MATERIAL SHALL NOT BE OTHER UNSUITABLE MATERIALS UNLESS SPECIFICALLY DIRECTED BY A SOILS ENGINEER WITH THE CONCURRENCE OF THE OWNER.</p> <p>D. COMPACTION OF THE CLAY AND OTHER SUITABLE MATERIALS, SHALL BE TO AT LEAST 93% OF THE MODIFIED PROCTOR DRY DENSITY WITHIN PROPOSED PAVEMENT AREAS, SIDEWALK, ETC. COMPACTION SHALL BE AT LEAST 95% OF THE MODIFIED PROCTOR WITHIN PROPOSED BUILDING PAD AREAS.</p>	<p>3. CONCRETE WORK</p> <p>A. ALL EXTERIOR CONCRETE SHALL BE PORTLAND CEMENT CONCRETE CLASS 91 OR PV PER (SSRBC) SECTION 1020.04 WITH AIR ENTRAINMENT OF NOT LESS THAN FIVE (5%) OR MORE THAN EIGHT (8%) PERCENT. CONCRETE SHALL BE A MINIMUM OF SIX (6) BAG MIX AND SHALL DEVELOP A MINIMUM OF 3,500 PSI COMPRESSIVE STRENGTH AT FOURTEEN (14) DAYS. ALL CONCRETE SHALL BE BRODCH FINISHED PERPENDICULAR TO THE DIRECTION OF TRAVEL. THE ADDITION OF CALCIUM CHLORIDE AND THE SUBSTITUTION OF FLY ASH FOR PORTLAND CEMENT IS PROHIBITED. 1.50 lbs of COLLATED, FILLBRATED, POLYPROPYLENE OLEFIN FIBERS 0.50 TO 0.75 INCHES IN LENGTH SHALL BE ADDED TO EACH CUBIC YARD OF CONCRETE USED FOR SIDEWALKS. THE FIBERS SHALL BE AS MANUFACTURED UNDER THE NAME "FIBERMESH" OR EQUAL.</p> <p>B. CONCRETE CURB AND/OR COMBINATION CURB AND GUTTER SHALL BE OF THE TYPE SHOWN ON THE PLANS. THE CONTRACTOR IS CAUTIONED TO REFER TO THE CONSTRUCTION STANDARDS AND THE PAVEMENT CROSS-SECTION TO DETERMINE THE GUTTER AND THE AGGREGATE BASE COURSE THICKNESS BENEATH THE CURB AND GUTTER. PREMOLDED FIBER EXPANSION JOINTS, WITH TWO 3/4" X 1/8" EPOXY COATED STEEL DOVEL BARS, SHALL BE INSTALLED AT SIXTY (60) FOOT INTERVALS AND AT ALL PCS, PTS AND CURB RETURNS. ALTERNATE ENDS OF THE DOVEL BARS SHALL BE GREASED AND FITTED WITH METAL EXPANSION TUBES. SAWED OR FORMED CONSTRUCTION JOINTS SHALL BE PROVIDED AT NO GREATER THAN FIFTEEN (15) FOOT INTERVALS BETWEEN EXPANSION JOINTS AND CAULKED. NO HONEY-COMBING OF THE CURB AND GUTTER WILL BE ACCEPTED.</p> <p>C. CURBS SHALL BE DEPRESSED AT LOCATIONS WHERE PUBLIC WALKS/PEDESTRIAN PATHS INTERSECT CURB LINES, AND OTHER LOCATIONS AS DIRECTED, FOR THE PURPOSE OF PROVIDING ACCESSIBILITY. (SEE CONSTRUCTION STANDARDS FOR DETAIL). BARRIER CURB SHALL ALSO BE DEPRESSED AT DRIVEWAY LOCATIONS.</p> <p>D. THE CURBS SHALL BE BACKFILLED AFTER THEIR CONSTRUCTION AND PRIOR TO THE PLACEMENT OF THE BASE COURSE. THE CONCRETE MUST CURE FOR AT LEAST SEVEN DAYS BEFORE THE CURBS ARE BACKFILLED.</p> <p>E. CONCRETE SIDEWALK SHALL BE IN ACCORDANCE WITH THE ABOVE AND THE PLANS. PROVIDE SCORED JOINTS AT 5 FOOT INTERVALS AND 1/2" PREMOLDED FIBER EXPANSION JOINTS AT 50 FOOT INTERVALS, AND ADJACENT TO CONCRETE CURBS, DRIVEWAYS, FOUNDATIONS, ETC.</p> <p>F. CONCRETE DRIVEWAY APRONS SHALL BE IN ACCORDANCE WITH THE ABOVE AND THE PLANS. PROVIDE 6" X 6" NO. 6 WELDED WIRE MESH 12" FINISHED GRADE ELEVATION. THE ADJACENT TO CURBS AND CONCRETE SIDEWALKS. PROVIDE SAWED OR FORMED CONTRACTION JOINT AT MID-POINT AND 15 FOOT MAXIMUM.</p> <p>G. STANDARD REINFORCED CONCRETE PAVEMENT SHALL BE IN ACCORDANCE WITH THE ABOVE AND THE PLANS. SAWED OR FORMED CONTRACTION EXPANSION JOINTS SHALL BE AS SHOWN ON THE PLANS.</p> <p>H. CONCRETE CURING AND PROTECTION SHALL BE IN ACCORDANCE WITH (SSRBC) -METHOD I, II, OR III.</p> <p>I. THE COST OF AGGREGATE BASE OR SUB-BASE UNDER CONCRETE WORK SHALL BE INCLUDED IN THE COST OF THE RESPECTIVE CONCRETE ITEM.</p> <p>4. FLEMBLE PAVEMENT</p> <p>A. THE PAVEMENT MATERIALS FOR BITUMINOUS STREETS, PARKING LOTS, DRIVEWAYS, SIDEWALKS AND PATHS SHALL BE AS DETAILED ON THE PLANS. UNLESS OTHERWISE SHOWN ON THE PLANS, THE FLEXIBLE PAVEMENTS SHALL CONSIST OF AGGREGATE BASE COURSE (I, II, 19.0, NS); BITUMINOUS CONCRETE BINDER COURSE; AND BITUMINOUS CONCRETE SURFACE COURSE. MIX "D" NS; OF THE THICKNESS AND MATERIALS SPECIFIED ON THE PLANS. THICKNESSES SPECIFIED SHALL BE CONSIDERED TO BE THE MINIMUM COMPACTED THICKNESS. THE PAVING IS TO BE DONE IN ACCORD WITH THE STANDARD SPECIFICATIONS FOR ROAD AND BRIDGE CONSTRUCTION IN ILLINOIS.</p> <p>B. ALL TRAFFIC SHALL BE KEPT OFF THE COMPLETED AGGREGATE BASE UNTIL THE BINDER COURSE IS LAID. THE AGGREGATE BASE SHALL BE UNIFORMLY PRIME COATED AT A RATE OF 0.4 TO 0.5 GALLONS PER SQUARE YARD PRIOR TO PLACING THE BINDER COURSE. PRIME COAT MATERIALS SHALL BE BITUMINOUS M.C. -30.</p> <p>C. PRIOR TO PLACEMENT OF THE SURFACE COURSE, THE BINDER COURSE SHALL BE CLEANED, AND TACK COATED IF DUSTY OR DIRTY OR THE TIME BETWEEN LEFTS EXCEEDS 30 DAYS. ALL DAMAGED AREAS IN THE BINDER, BASE OR CURB SHALL BE REPAIRED TO THE SATISFACTION OF THE OWNER PRIOR TO LAYING THE SURFACE COURSE. THE CONTRACTOR SHALL PROVIDE WHATEVER EQUIPMENT AND MANPOWER NECESSARY, INCLUDING THE USE OF POWER BROOMS IF REQUIRED BY THE OWNER, TO PREPARE THE PAVEMENT FOR APPLICATION OF THE SURFACE COURSE. THE TACK COAT SHALL BE UNIFORMLY APPLIED TO THE BINDER COURSE AT A RATE OF 0.35 TO 0.10 GALLONS PER SQUARE YARD. TACK COAT SHALL BE AS SPECIFIED IN (SSRBC) SECTION 406.02.</p> <p>D. SEAMS IN BASE, BINDER AND SURFACE COURSE SHALL BE STAGGERED A MINIMUM OF 6'.</p> <p>E. FOR NEW STREETS, THE CONTRACTOR SHALL PERMIT THE BITUMINOUS CONCRETE BINDER COURSE TO WEATHER ONE (1) WINTER SEASON PRIOR TO THE INSTALLATION OF THE BITUMINOUS CONCRETE SURFACE COURSE UNLESS OTHERWISE SPECIFIED BY THE MUNICIPAL ENGINEER OR OWNER.</p>	<p>2. BEDDING:</p> <p>A. BEDDING SHALL CONSIST OF A MINIMUM OF FOUR (4") INCHES OF COMPACTED CRUSHED GRAVEL OR STONE, 1/4" - 3/4" IN SIZE. THE SEWER SHALL HAVE MECHANICALLY TAMPED CRUSHED GRAVEL OR STONE COVER ABOVE THE TOP OF THE PIPE TO A MINIMUM OF TWELVE (12") INCHES FOR PVC PIPE AND TO THE SPRING LINE FOR DIP. THE BEDDING AND COVER MATERIAL SHALL BE ASTM D-2321 CLASS II FOR PVC PIPE AND ASTM D-445 SIZE #1 FOR DIP PIPE. THE COST OF THE BEDDING AND COVER SHALL BE MERGED WITH THE UNIT PRICE BID FOR THE SEWER.</p> <p>B. ALL UNSUITABLE MATERIAL SHALL BE REMOVED BELOW THE PROPOSED SANITARY SEWER AND REPLACED WITH COMPACTED CA-7 CRUSHED GRAVEL OR STONE.</p> <p>C. ALL TRENCHES BENEATH PROPOSED OR EXISTING UTILITIES, PAVEMENTS, ROADWAYS, SIDEWALKS, AND FOR A DISTANCE OF FIVE (5) FEET ON EITHER SIDE OF SAME, AND/OR WHERE SHOWN ON THE PLANS, SHALL BE BACKFILLED WITH SELECT GRANULAR BACKFILL (CA-7) AND THOROUGHLY MECHANICALLY COMPACTED IN 8" THICK LAYERS (MEASUREMENT) LAYERS. JETTING WITH WATER IS NOT PERMITTED. REFER TO THE TRENCH BACKFILL LIMITS DETAIL.</p> <p>3. MANHOLES:</p> <p>A. SANITARY SEWER MANHOLES SHALL BE 4'-0" I.D. PRECAST CONCRETE SECTIONS CONFORMING TO ASTM D-478 WITH PREFORMED BITUMINOUS OR "O" RING JOINTS, IN ACCORDANCE WITH MUNICIPAL REGULATIONS, AND HAVE AN ECCENTRIC CONE INSTALLED TO LINE UP WITH THE MANHOLE STEPS. ALL MANHOLE STEPS SHALL BE AT 16" O.C. SIMILAR TO NEENAH R-1990.</p> <p>B. ALL PIPE CONNECTION OPENINGS SHALL BE PRECAST WITH RESILIENT RUBBER WATER TIGHT SLEEVES. THE BOTTOM OF MANHOLE SHALL HAVE A CONCRETE BENCH POURS TO FACILITATE SMOOTH FLOWS.</p> <p>4. FRAMES AND LIDS:</p> <p>A. ALL SANITARY SEWER MANHOLE FRAMES AND LIDS SHALL BE NEENAH R-1712 UNLESS OTHERWISE NOTED ON THE PLANS. THE LIDS SHALL HAVE RECESSED (CONCEALED) PICK HOLE AND BE SELF SEALING WITH AN "O" RING GASKET. THE LIDS SHALL HAVE THE WORDS "SANITARY" EMBOSSED ON THE SURFACE. THE JOINTS BETWEEN FRAME AND CONCRETE SECTION SHALL BE SEALED WITH A BUTYL ROPE.</p> <p>B. A MAXIMUM OF EIGHT (8) INCHES OF CONCRETE ADJUSTING RINGS SHALL BE USED TO ADJUST FRAME ELEVATIONS. RINGS SHALL BE SEALED TOGETHER WITH BUTYL ROPE.</p> <p>5. DROP MANHOLE ASSEMBLIES:</p> <p>A. DROP MANHOLE ASSEMBLIES: DROP MANHOLE ASSEMBLIES SHALL BE PROVIDED AT THE JUNCTION OF SANITARY SEWERS WHERE THE DIFFERENCE IN INVERT GRADES EXCEEDS TWO FEET (2'), OR AS SHOWN ON THE PLANS. THE ENTIRE DROP ASSEMBLY SHALL BE CAST IN CONCRETE MONOLITHICALLY WITH THE MANHOLE BARREL SECTION.</p> <p>6. CLEANING:</p> <p>A. ALL MANHOLES AND PIPES SHALL BE THOROUGHLY CLEANED OF DIRT AND DEBRIS, AND ALL VISIBLE LEAKAGE ELIMINATED, BEFORE FINAL INSPECTION AND ACCEPTANCE.</p> <p>7. TESTING:</p> <p>A. DEFLECTION AND LEAKAGE TESTING WILL BE REQUIRED. THE PROCEDURE AND ALLOWABLE TESTING LIMITS SHALL BE AS SPECIFIED IN THE "STANDARD SPECIFICATIONS FOR WATER AND SEWER MAIN CONSTRUCTION IN ILLINOIS" OR MUNICIPAL CODES. IN THE EVENT OF A DISCREPANCY BETWEEN THE STANDARD SPECIFICATIONS AND THE MUNICIPAL CODE, THE MUNICIPAL CODE SHALL GOVERN. THE FULL LENGTH OF THE SANITARY SEWER IS REQUIRED TO BE BOTH AIR TESTED AND DEFLECTION TESTED.</p> <p>B. TESTING THE ALIGNMENT/STRAIGHTNESS SHALL BE IN ACCORDANCE WITH MUNICIPAL CODE.</p> <p>C. TESTING OF MANHOLES TO BE IN ACCORDANCE WITH ASTM C-969.</p> <p>8. TELEVISIONING:</p> <p>A. ALL SANITARY SEWERS SHALL BE TELEVIEWED AND A COPY OF THE TAPE /DVD AND A WRITTEN REPORT SHALL BE SUBMITTED AND REVIEWED BY THE OWNER OR MUNICIPALITY BEFORE FINAL ACCEPTANCE. THE REPORT SHALL INCLUDE STUB LOCATION AS WELL AS A DESCRIPTION OF ALL DEFECTS, WATER LEVEL, LEAKS AND LENGTHS. IDENTIFY MANHOLE TO MANHOLE BOTH VERBALLY AND ON-SCREEN USING MANHOLE NUMBERS FROM APPROVED PLANS. ORDER OF WRITTEN REPORT SHALL BE THE SAME AS THE VIDEO TAPES/DVDS.</p> <p>9. TEST RESULTS:</p> <p>A. IF THE SANITARY SEWER INSTALLATION FAILS TO MEET THE TEST REQUIREMENTS SPECIFIED, THE CONTRACTOR SHALL DETERMINE THE CAUSE OR CAUSES OF THE DEFECT AND SHALL, AT HIS OWN EXPENSE, REPAIR OR REPLACE ALL MATERIALS, AND WORKSMANSHIP AS MAY BE NECESSARY TO CORRECT WITH THE TEST REQUIREMENTS.</p> <p>10. CERTIFICATION:</p> <p>A. CONTRACTOR SHALL SUBMIT CERTIFIED COPIES OF ALL REPORTS OF TESTS CONDUCTED BY AN INDEPENDENT LABORATORY BEFORE INSTALLATION OF PVC PLASTIC PIPE. TESTS SHALL BE CONDUCTED IN ACCORDANCE WITH STANDARD METHOD OF TEST FOR "EXTERNAL LOADING PROPERTIES OF PLASTIC PIPE BY PARALLEL PLATE LOADING". ASTM STANDARDS D-2412 OR D-2241 AS APPROPRIATE FOR THE PIPE TO BE USED. TESTS SHALL ALSO BE CONDUCTED TO DEMONSTRATE JOINT PERFORMANCE AT 5% MAXIMUM DIAMETRIC DEFLECTION OF THE SPIGOT.</p> <p>11. RECORD DRAWINGS:</p> <p>A. THE CONTRACTOR SHALL PROVIDE ALL INFORMATION TO PREPARE RECORD DRAWINGS (S) INCLUDING SERVICE STUB LOCATIONS TO SPACECO. SPACECO SHALL PREPARE RECORD DRAWINGS AND SUBMIT TO APPROPRIATE PUBLIC AGENCIES. IF FINAL MEASUREMENTS INDICATE DEFICIENCIES, THE CONTRACTOR, AT HIS OWN COST, WILL ADJUST MANHOLES AND/OR SEWERS TO PROPER ELEVATIONS AND OTHERWISE CORRECT THE DEFICIENCIES.</p>	<p>WATERMAIN NOTES</p> <p>1. PIPE MATERIALS:</p> <p>A. WATERMANS OR SERVICES 3" OR LARGER IN DIAMETER SHALL BE CONSTRUCTED OF BITUMINOUS COATED, CEMENT LINED DUCTILE IRON PIPE, CLASS 52, CONFORMING TO ANSI A-21.50 (AWWA C150) AND ANSI A-21.51 (AWWA C151). CEMENT MORTAR LINING SHALL CONFORM TO ANSI A-21.4 (AWWA C-104</p>

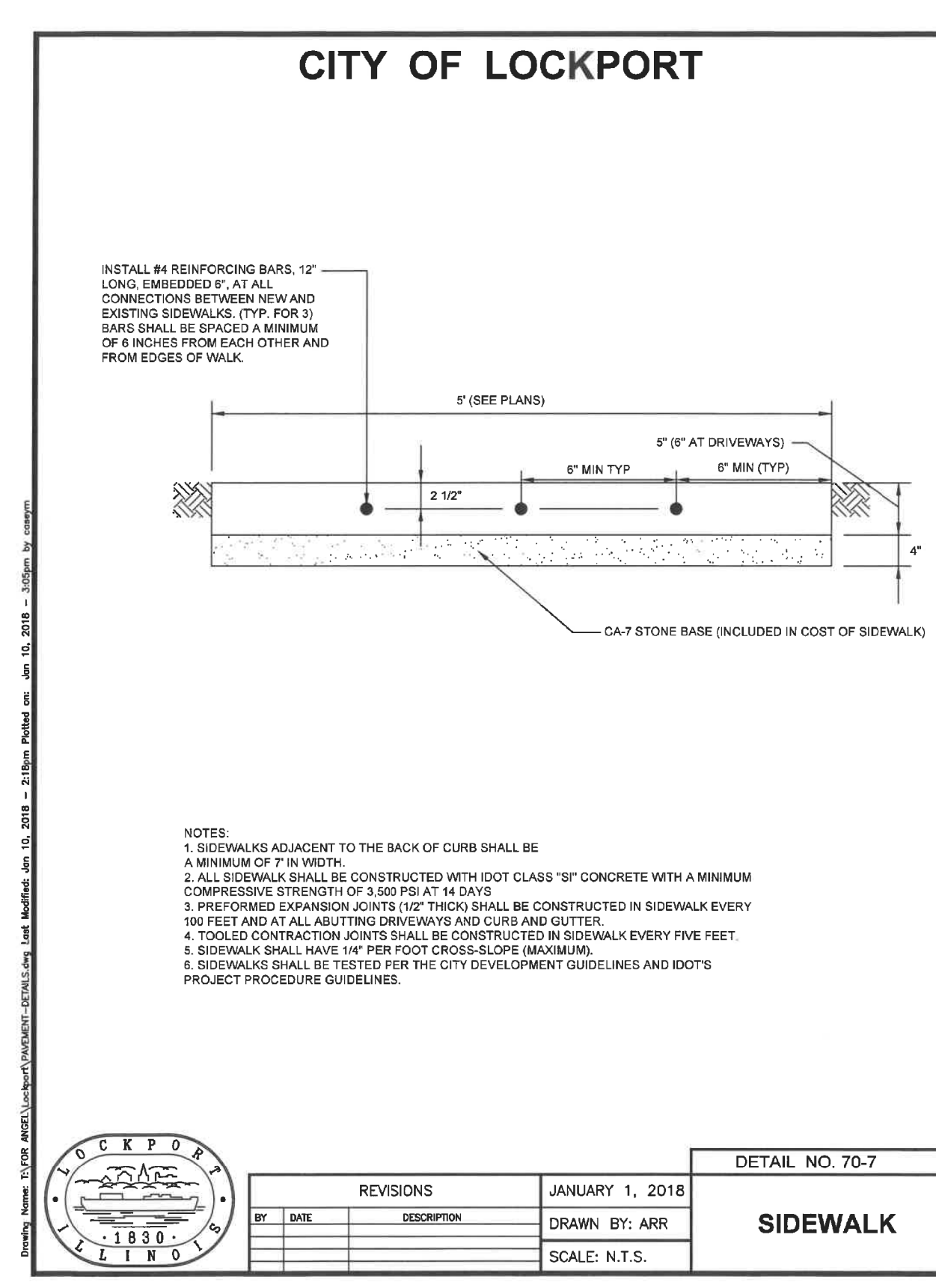
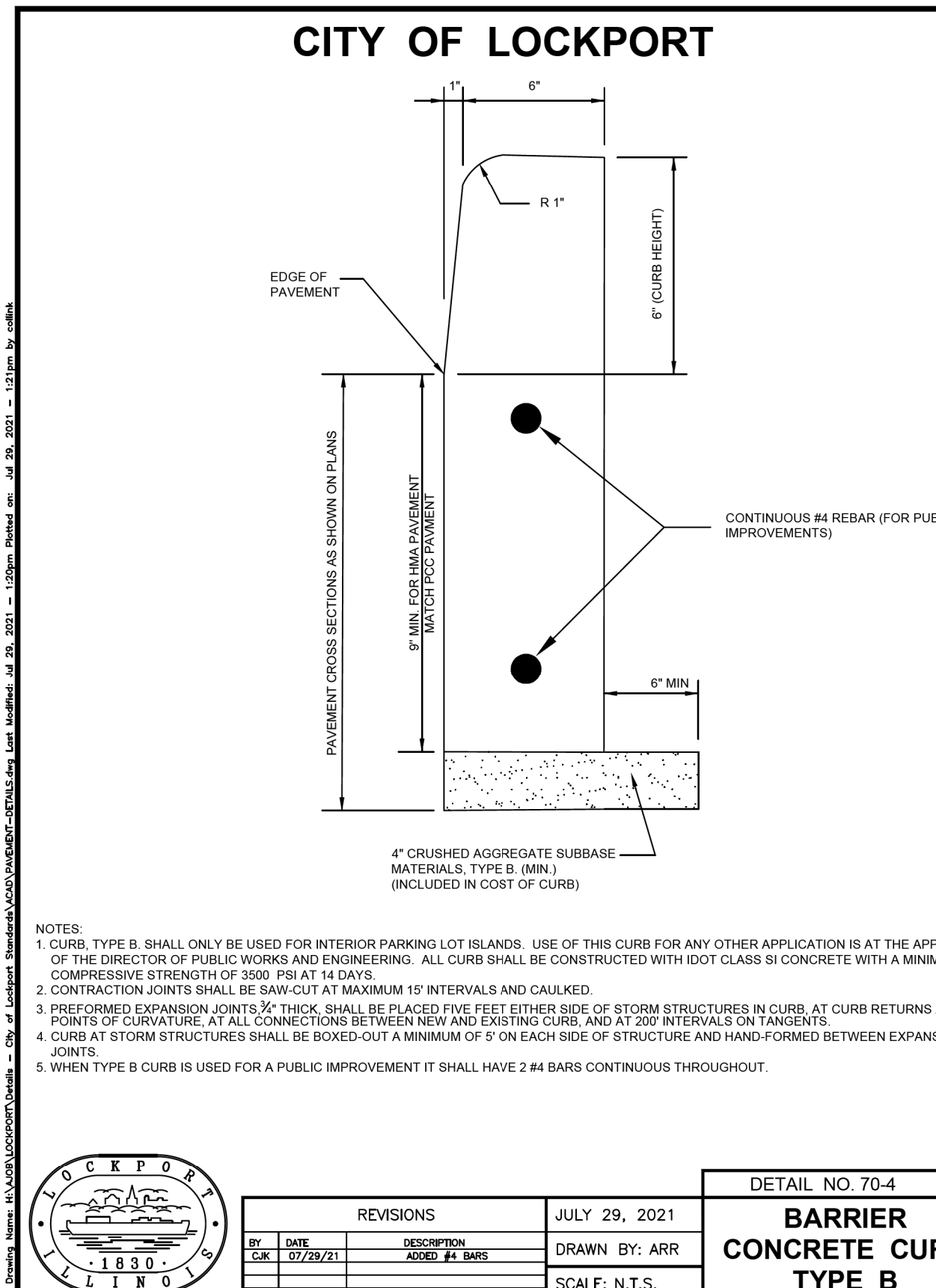
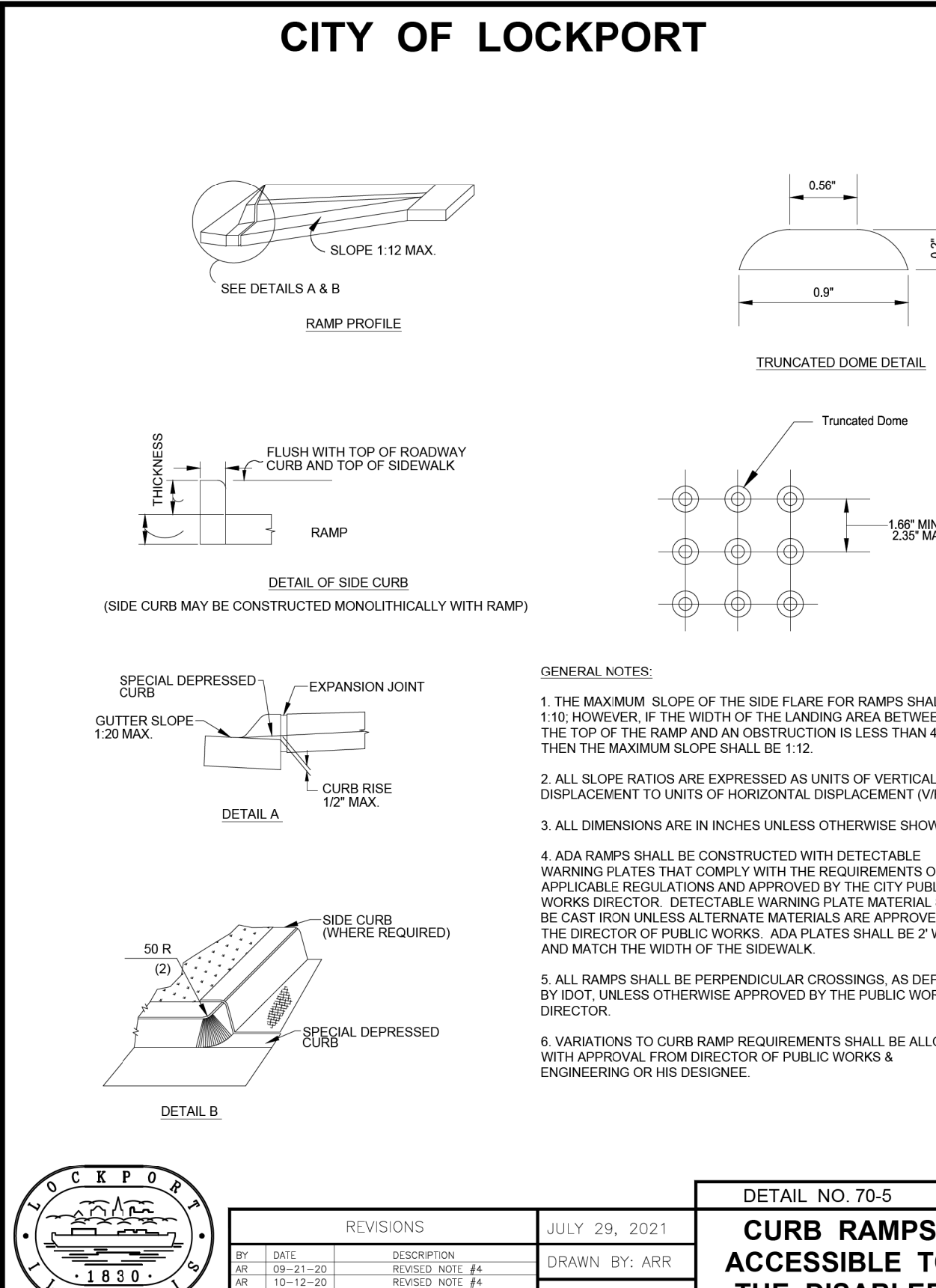
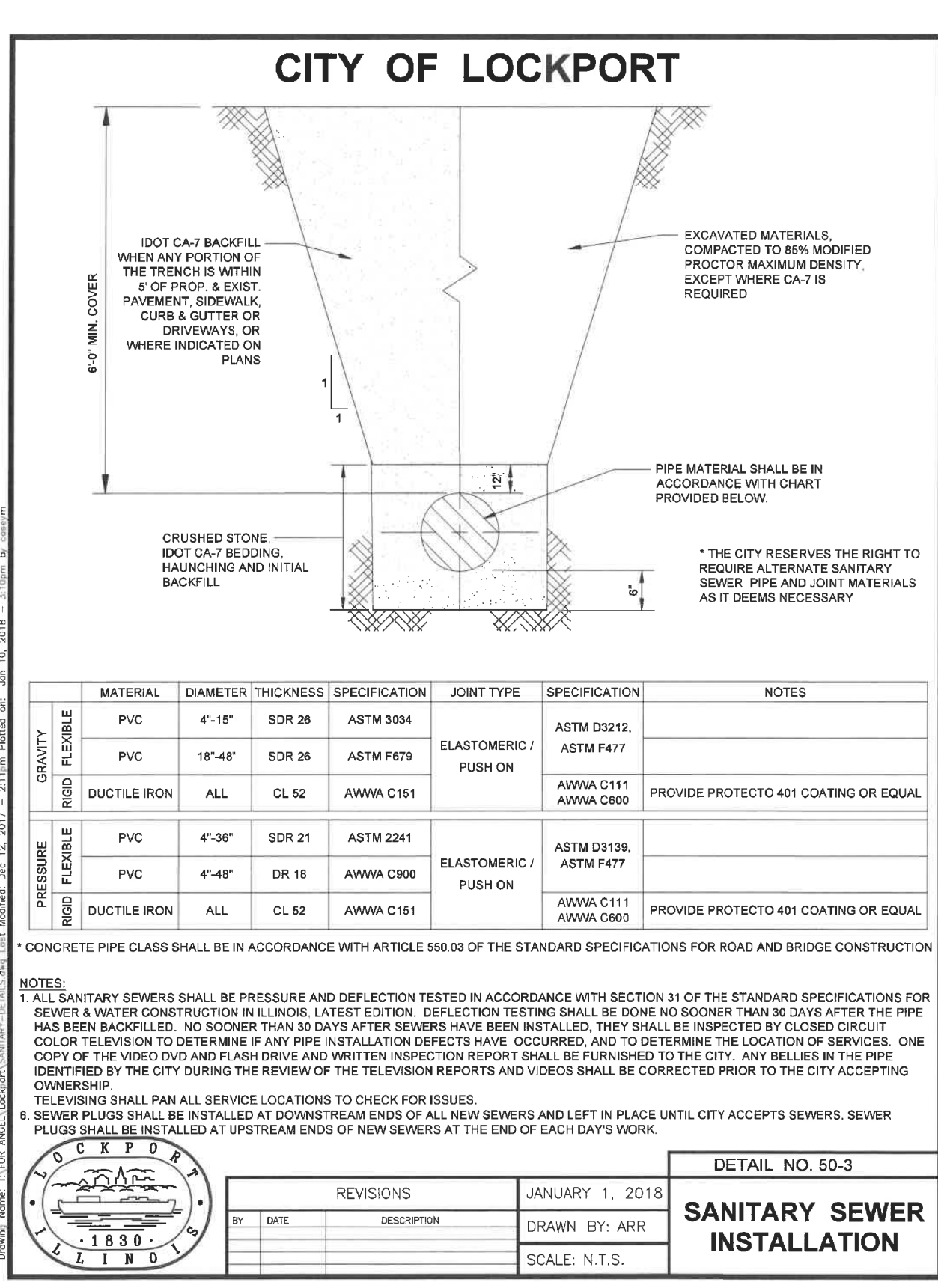
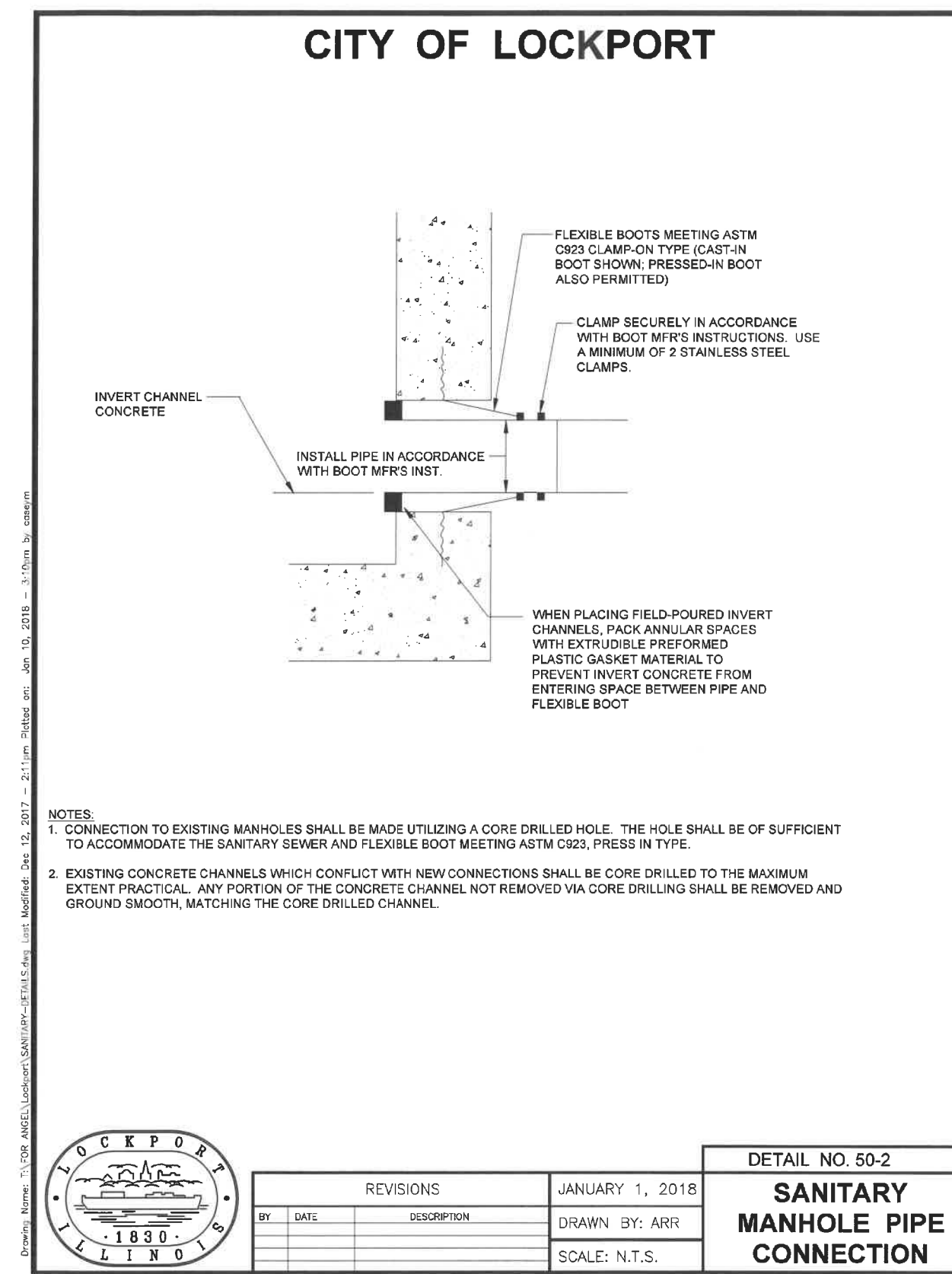
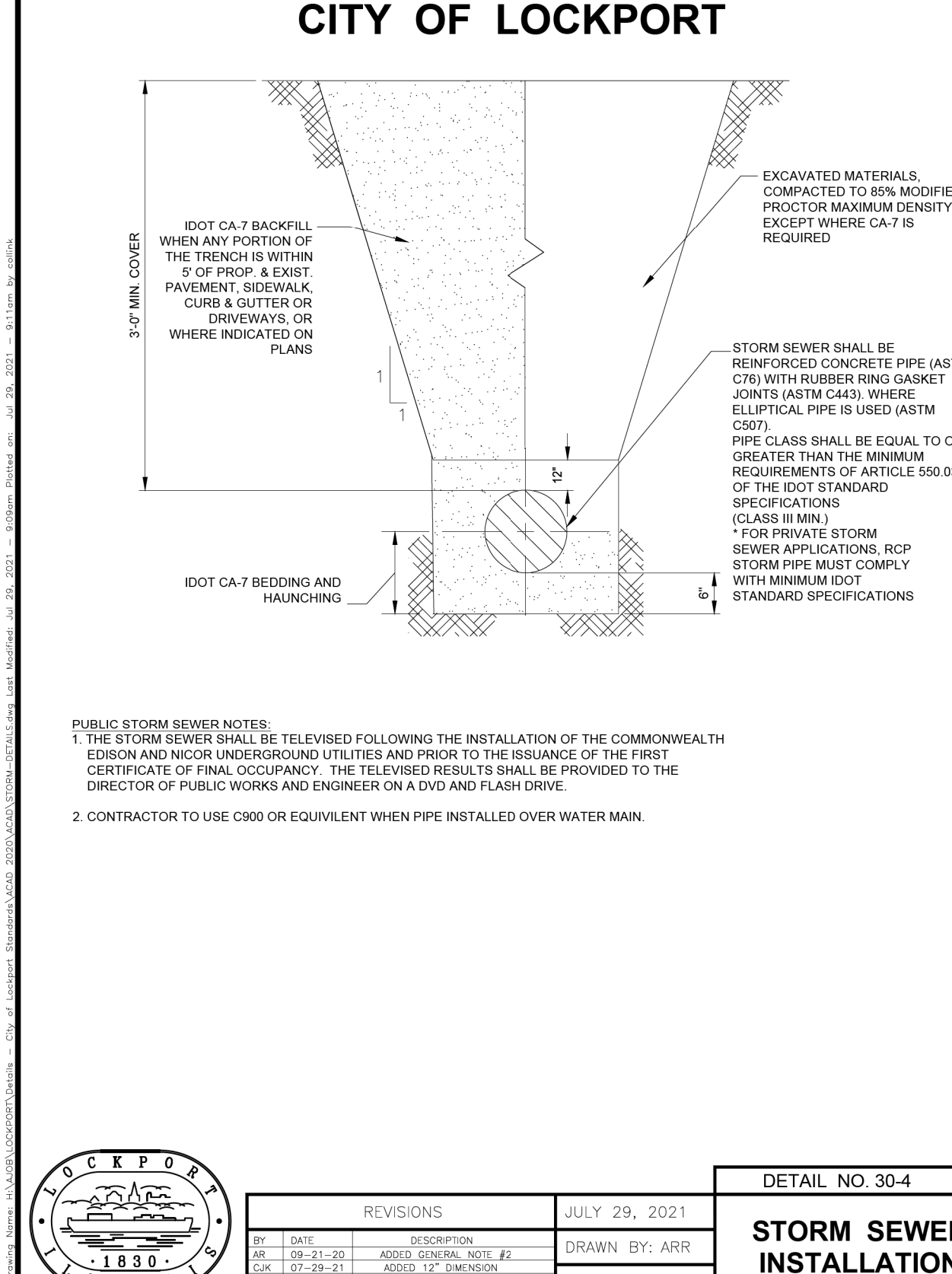
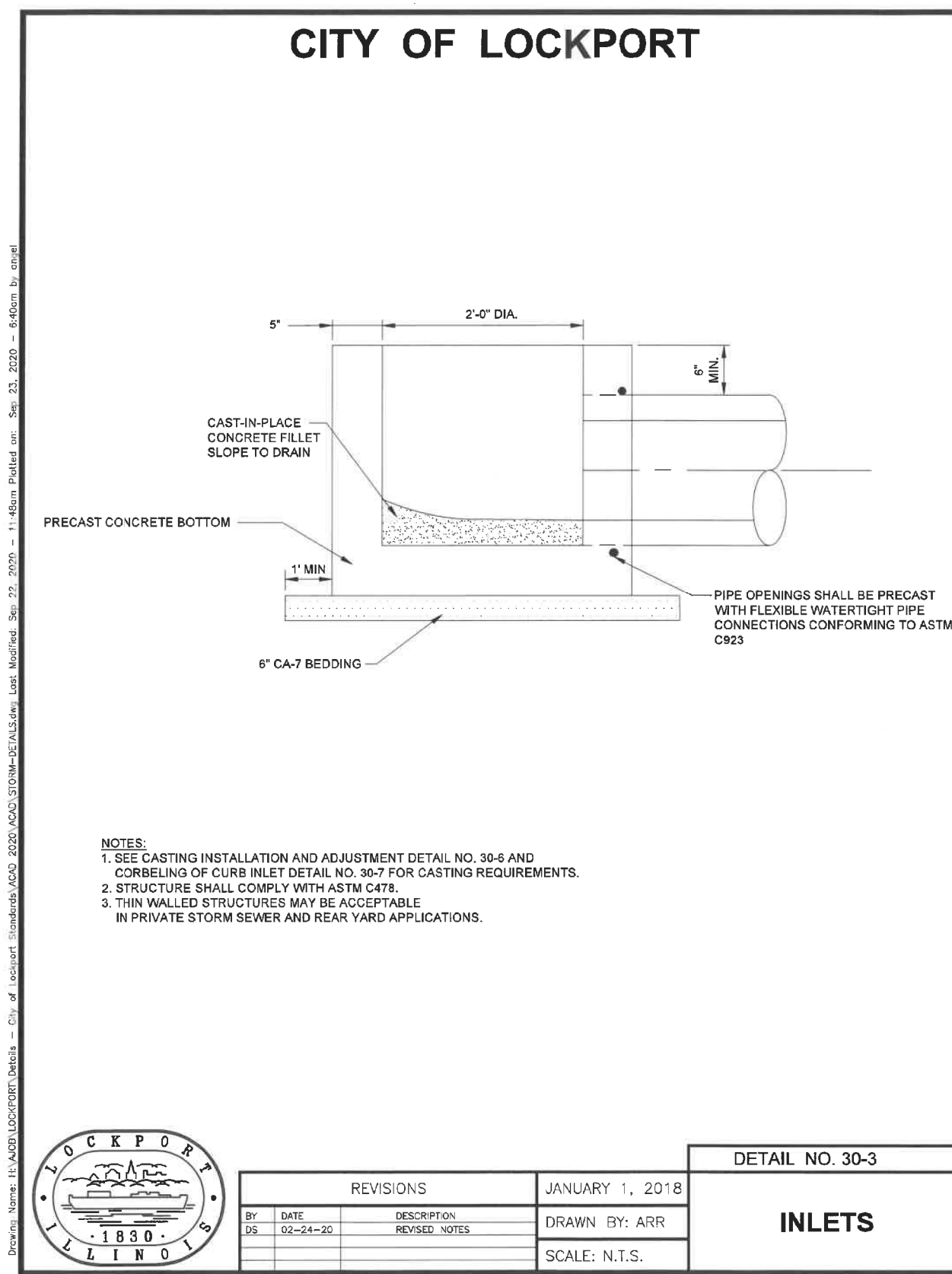
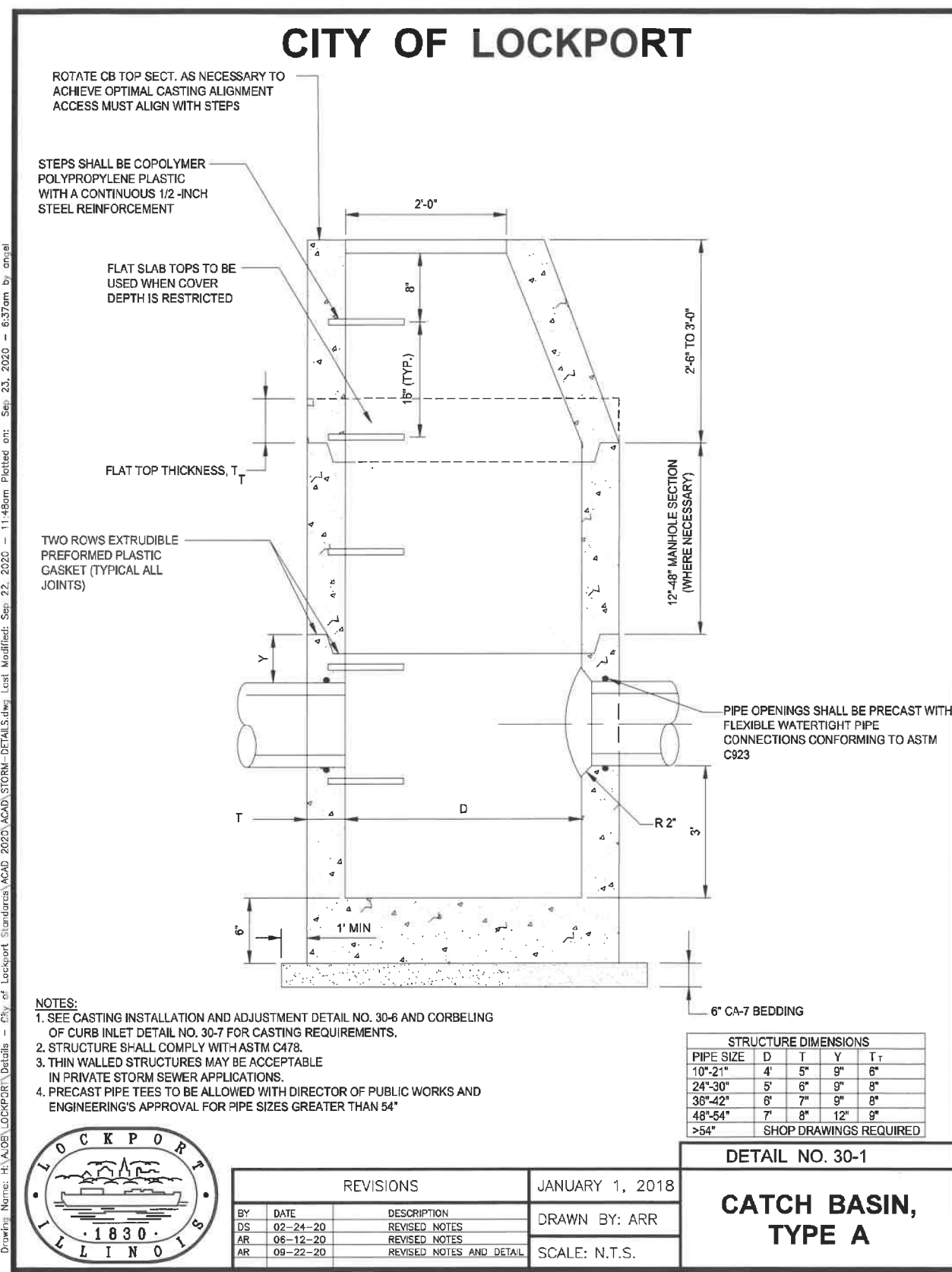

**DETAILS - 1**

## ROSE CENTER LOCKPORT LOT 1A - PANDA EXPRESS LOCKPORT, ILLINOIS

NO.	DATE	REMARKS
1	3/16/23	PER CITY REVIEW
2	3/23/23	PER CITY REVIEW

CONSULTING ENGINEERS  
**SITE DEVELOPMENT ENGINEERS**  
 LAND SURVEYORS  
 SPACECO INC.  
 224 1/2 N. Liberty Street,  
 Morris, Illinois 60450  
 Phone: (615) 941-0260 Fax: (615) 941-0263

FILENAME:  
 C11\_5225-03-01  
 DATE:  
 01/30/23  
 JOB NO.  
 5225-03-M  
 SHEET  
**D1**  
 11 OF 11



**Planning and Zoning Memorandum**

**Case # 2023-003**

TO: Plan & Zoning Commission

FROM: Kimberly Phillips, City Planner

DATE: April 5, 2023

SUBJECT: Final Development Plan Review for a Restaurant with a Drive-thru Facility, Lot 1A (Panda Express) in Rose Lockport Center

---

**I. SUMMARY/REQUESTED ACTION**

The applicant Derek Knight on behalf of Panda Express Inc., has submitted an application for approval of Final Development Plans for a stand-alone 2,667 square foot restaurant with drive thru facility on the Lot 1A of Rose Lockport Center (Planned Development). The new restaurant will be operated under the Panda Express, Inc. brands.

Development Plans being reviewed include the following:

- 1) Final Site Plan, Prepared by Newground, revision date 3/24/23  
(Final Site Plan, Elevations, Signage & Photometric)
- 2) Final Landscape Plan, Prepared by Kimley Horn, dated 3/28/23
- 3) Final Engineering Plan, Prepared by Space Co Inc. dated 4/2/23

---

**II. GENERAL INFORMATION**

- 1) **Petitioner:** Panda Express, Inc.
- 2) **Parcel size:** 0.998 acres
- 3) **PIN number:** 11-04-24-201-016-0000, (new PIN pending re-plat)
- 4) **Location:** Rose Lockport Center Lot 1A (Re-subdivision)  
Near the southwest corner of 159<sup>th</sup> and Farrell Road
- 5) **Zoning:** C2 Community Commercial  
Special Use for Planned Development

---

**III. PROJECT OVERVIEW**

The proposed development is located on Lot 1A of Rose Lockport Center (Resubdivision). The proposed restaurant consists of a 2,667 square foot commercial building containing an indoor eating area and kitchen with drive-thru window. The drive-thru facility use is an integral part of Panda Express's business plan and provides customers a desired convenience. The subject property is impressed with a Special Use Permit for the drive thru under the approved PD for Rose Lockport Center.

### **Site Plan**

The final site plan is in substantial compliance with City development requirements.

- The Site Plan illustrates a single story 2,667 square foot building with drive thru facility centered on Lot 1A.
- Adequate vehicle queueing is provided in the double-lane drive thru. The Plan demonstrates two stack drive thru lanes with queueing for up to nineteen (19) vehicles. There is not a bypass lane, however, circulation is provided by the Rose Lockport Center internal driveway.
- Site access is provided in two main locations. There is a full access point off of Farrell Road across from the Jewel/Osco access point and there is also full access (with a traffic signal) at the Aldi's access point. Additionally, cross access is provided to the existing Culver's Restaurant, which currently has a full access point to Farrell Road.
- Circulation is provided on two (2) sides of the building.
- An enclosure for the trash dumpsters is provided (west/rear of the building). The proposed enclosure will be constructed of brick to match the building.

### **Sidewalks**

Sidewalk connection is provided via a pedestrian walkway at the northeast corner of the site connecting to the public sidewalk along Farrell Road and on the west side via the sidewalk being constructed at the connection to Clover Ridge.

### **Parking**

Parking is in compliance with City code and approved agreements of Lockport Square. For a drive-thru facility, one space per 200 sf of floor area is required, totaling thirteen (13) spaces. Thirty-seven (37) spaces are provided.

### **Final Landscape Plan**

A Final Landscape Plan was submitted and is in conformance with City requirements. Requirements such as perimeter landscaping, foundation landscaping, and interior parking lot landscaping have been met and are comprised of a variety trees and shrubs, and perennials.

- The Landscape Plan provides a (required) landscaped strip which creates separation of the double drive-thru lanes.
- Sod has been specified in the proposed turf areas.

### **Final Elevation Plans**

Final Elevations were submitted and are in conformance with City requirements.

- The single-story building is proposed as a mix of "Thin Brick", wood composite siding, stone veneer, and glass storefront.
- The front façade (east elevation) contains 81% Class I materials and 9% Class II. The north elevation contains 86% Class I materials and 5% Class II materials. The west elevation contains 60% Class I materials and 16% Class II materials. The south elevation contains 80% Class I materials and 11% Class II materials.
- Architectural interest is provided on the north side by a "swoop" element comprised of black aluminum over the entry doors and windows, circular window trim and vertical elements are provided.
- The building design will incorporate parapets to screen the equipment.
- The Drive thru window is illustrated on the south elevation. Chinese symbols are displayed in a decorative horizontal band, this will be considered wall signage.

**Final Lighting Plan**

A Photometric Plan was submitted and is in compliance with City’s code. All fixtures are fully cut-off and shielded.

**Signage**

- The signage package for the proposed restaurant is provided. As such, the signage package contained wall signage, drive thru signage (with two menu boards, speaker post/clearance bar) and freestanding signage. Up to two menu boards are allowed for drive thru lanes and two are provided. However the sign exceeds the maximum sign area of 24 sf with a total display area of approximately 36 sf. Staff supports the request for additional display area.
- The monument sign is illustrated with a masonry base as required. (However, the material is not identified). The circle shaped Panda Express brand is internally illuminated and centered over the masonry base.
- Wall signage is illustrated on the elevations and is comprised of red channel set letters. The Panda Express brand “round cabinet signs” are used as secondary wall signage on the north, south, and west elevations. Wall signage area has been exceeded on the south elevation, however, the applicant’s design team is working with staff to meet wall signage requirements.
- Sign permits will be required at the time of sign construction. Each permit will be reviewed for compliance with the signage plan contained in the Final Development Plan.

**Engineering Review**

Final Engineering Plans have been reviewed by the City’s Development Engineering Consultant. All review comments have been addressed.

**Fire District, Building Official and Police Department Review**

The Lockport Township Fire Protection District has reviewed the development plan and has no comments related to the development plan at this time.

The City’s Building Official has reviewed the development plan and has no comments related to the development plan at this time.

The City’s Police Department reviewed the development plan and has no comments related to the development plan at this time.

**IV. RECOMMENDATION**

Should the Commission find the Final Development Plans for a Restaurant with Drive Thru Facility in Rose Lockport Center, Lot 1A acceptable the following motion is suggested:

A motion to approve Final Development Plans for a 2,667 sf Commercial Building for a Restaurant with Drive Thru Facility in Rose Lockport Center, Lot 1A

**V. ATTACHMENT(S)**

1. Panda Express Project Narrative
2. Subdivision Plat (For Reference)
3. Final Site Plan, Prepared by Newground, revision date 3/24/23
4. (Final Site Plan, Elevations, Signage & Photometric)
5. Final Landscape Plan, Prepared by Kimley Horn, dated 3/28/23

6. Final Engineering Plan, Prepared by Space Co Inc. dated 4/2/23



## City Council

### Agenda Memorandum

Item # PW-1

**To:** Mayor & City Council

**From:** Brent Cann, Public Works Director

**Subject:** Release of Bond and Initial Acceptance of Site Improvements for Homer Tree Service, Inc.

**Date:** Wednesday, May 17, 2023

#### **BACKGROUND/HISTORY**

On March 29, 2021, a surety bond was established for the Homer Tree Service, Inc. site expansion in the amount of \$408,996. All improvements have been completed, inspected, and approved by the City of Lockport Engineering Department. This bond release will be contingent on the City receiving the 12-month maintenance guarantee from the owner for 10% of the original amount of the surety.

#### **PROS/CONS/ALTERNATIVES**

N/A

#### **RECOMMENDATION**

Approve Resolution No. 23-040 to release the surety bond for the Homer Tree Service, Inc. site, contingent on the City receiving the 12-month maintenance guarantee from the developer for 10% of the original amount of the surety.

#### **ATTACHMENTS**

[Resolution No. 23-040 Release of bond and initial acceptance of Site Improvements for Homer Tree Service, Inc.](#)

[Recommendation for Bond Release and Initial Acceptance](#)

[Bond No. 30124766](#)

#### **SPECIFIC CITY COUNCIL ACTION REQUIRED**

Approve Resolution No. 23-040 for the Release of Bond and Initial Acceptance of Site Improvements for Homer Tree Service, Inc.



**RESOLUTION NO. 23-040**

**A RESOLUTION FOR RELEASE OF BOND AND INITIAL ACCEPTANCE OF SITE IMPROVEMENTS FOR HOMER TREE SERVICE, INC.**

**WHEREAS**, the Owner of Homer Tree Service, Inc. posted Bond No. 30124766 on March 29, 2021 in the amount of \$408,996.00 for site improvements; and

**WHEREAS**, all improvements have been completed, inspected, and approved by the City of Lockport Engineering Department, therefore the project is ready for close-out; and

**WHEREAS**, release of the Bond will be contingent upon receipt of a one year maintenance bond of 10% of original Bond amount;

**NOW, THEREFORE, BE IT RESOLVED BY THE MAYOR AND CITY COUNCIL OF THE CITY OF LOCKPORT, ILLINOIS, AS FOLLOWS:**

**SECTION ONE:** The Mayor and the City Council hereby authorize the release of Bond No. 30124766 in the amount of \$408,996.00.

**SECTION TWO:** This Resolution shall become effective immediately upon passage and approval.

**PASSED and APPROVED** this \_\_\_\_\_ day of \_\_\_\_\_, 2023, with:

\_\_\_\_\_ALDERMEN voting aye      \_\_\_\_\_ALDERMEN abstaining

\_\_\_\_\_ALDERMEN voting nay      \_\_\_\_\_ALDERMEN absent

The MAYOR voting aye \_\_\_\_\_, voting nay \_\_\_\_\_, not voting \_\_\_\_\_

\_\_\_\_\_ KAIRIS      \_\_\_\_\_ DESKIN      \_\_\_\_\_ MCDONALD      \_\_\_\_\_ GILLOGLY

\_\_\_\_\_ BERGBOWER      \_\_\_\_\_ PUGH      \_\_\_\_\_ SABAN      \_\_\_\_\_ BARTELSEN

\_\_\_\_\_ MAYOR

\_\_\_\_\_  
Steven Streit, Mayor

**ATTEST:**

\_\_\_\_\_  
Kathleen Gentile, City Clerk

DATE: April 20, 2023

SUBJECT: Bond Release and Initial Acceptance Recommendation  
Homer Tree Expansion Yard

Chamlin Engineering has reviewed the request for bond release and Initial Acceptance of site improvements for Homer Tree Expansion Yard on behalf of the City of Lockport and recommend approval of both.

The developer has addressed inspection punchlist items for this development and has submitted as-built record drawings that have since been approved. Additionally, the developer has submitted a signed copy of a Certificate of Initial Acceptance to the Director of Public Works and Engineering in accordance with City of Lockport Development Code Section 153.40.050 . This form is attached.

The City Council's formal approval of the bond release and Initial Acceptance of site improvements is contingent on the City receiving 12-month maintenance guarantees from the developer for 10% the original amount of the bond. Formal City Council approval followed by the City receipt and acceptance of the maintenance guarantee shall mark the beginning of a 12-month guarantee period covering the workmanship and materials incorporated into the required improvements. Final Acceptance procedures will be according to Section 153.40.060.

This and all previous reviews did not include field verification of elevations, grades, and/or topography as shown on the plan, and we disclaim responsibility for any errors or omissions. This review is for general conformance to the City of Lockport Development Code, Zoning Ordinance, and other applicable guidelines. Review and approval of the plans does not relieve the developer from adhering to all City of Lockport requirements. Any additional measures required as a result of actual field conditions shall be at the discretion of the City of Lockport Director of Public Works.

Peru Office

4152 Progress Boulevard • Peru, IL 61354  
Phone 815.223.3344 • Fax 815.223.3348  
peru@chamlin.com

Ottawa Office

218 West Lafayette Street • Ottawa, IL 61350  
Phone 815.434.7225 • Fax 815.434.2831  
ottawa@chamlin.com

Mendota Office

903 Main Street • Mendota, IL 61342  
Phone 815.539.8137 • Fax 815.224.8575  
mendota@chamlin.com

**SUBDIVISION BOND**

Bond No.: 30124766

Principal Amount: \$408,996.00

KNOW ALL MEN BY THESE PRESENTS, that we Homer Tree Service, Inc.  
as Principal, and Western Surety Company a SD  
Corporation, as Surety, are held and firmly bound unto City of Lockport,  
as Oblige, in the penal sum of Four Hundred Eight Thousand Nine Hundred Ninety Six Dollars and  
00/100 (Dollars) (\$408,996.00), lawful money of the  
United States of America, for the payment of which well and truly to be made, we bind ourselves, our  
heirs, executors, administrators, successors and assigns, jointly and severally, firmly by these presents.

WHEREAS, Homer Tree Service, Inc. has agreed to construct in  
Subdivision, in Northeast corner of archer ave and Basham Drive the following improvements:

including erosion control, grading, stormwater detention,  
storm sewer, asphalt grindings lot, fencing, landscaping, and other site improvements typical to  
a development of this type.

NOW, THEREFORE, THE CONDITION OF THIS OBLIGATION IS SUCH, that if the said Principal  
shall construct, or have constructed, the improvements herein described, and shall save the Oblige  
harmless from any loss, cost or damage by reason of its failure to complete said work, then this obligation  
shall be null and void, otherwise to remain in full force and effect, and the Surety, upon receipt of a  
resolution of the Oblige indicating that the improvements have not been installed or completed, will  
complete the improvements or pay to the Oblige such amount up to the Principal amount of this bond  
which will allow the Oblige to complete the improvements.

Upon approval by the Oblige, this instrument may be proportionately reduced as the public  
improvements are completed.

Signed, sealed and dated, this 29th day of March, 2021

Homer Tree Service, Inc.  
Principal

Western Surety Company  
Surety



By: \_\_\_\_\_

By: [Signature]  
Kristen Schmidt Attorney-in-Fact

**SUBDIVISION BOND  
LABOR & MATERIAL/PAYMENT**

KNOW ALL MEN BY THESE PRESENTS: That we, Homer Tree Service, Inc.  
as Principal, and Western Surety Company, as  
Surety, are held and firmly bound unto City of Lockport, as  
Obligee, in the sum of Four Hundred Eight Thousand Nine Hundred Ninety Six Dollars and 00/100  
DOLLARS (\$408,996.00), lawful money of the United States of America, for the payment of  
which sum will and truly to be made, we bind ourselves jointly and severally, firmly by these presents.

THE CONDITION OF THIS OLBIGATION IS SUCH, That, Whereas, said Principal has entered into a  
Subdivision Agreement with the Obligee, dated October 30, 2020, in which said Principal  
agrees to construct designated public improvements, as follows:

including erosion control, grading, stormwater detention,  
storm sewer, asphalt grindings lot, fencing, landscaping, and other site improvements typical to  
a development of this type.

And, as a condition of approving said Subdivision, the Principal is required to give Labor and Material  
Payment Bond as herein provided.

NOW, THEREFORE, if said Principal and/or contractor or subcontractor fails to pay for any materials,  
provisions, or rented equipment used in, upon, or for or about the construction of the public improvements  
for performance of the work to be done, or any work or labor done of any kind, in or on such  
improvements, said surety will pay the same in an amount not exceeding the sum set forth above.

This bond shall insure to the benefit of the contractor, his subcontractors, and to persons renting  
equipment or furnishing labor and materials to them for the improvements.

SIGNED, SEALED, DATED: March 29, 2021

Homer Tree Service, Inc.  
(Principal)

Western Surety Company  
(Surety)

By:

\_\_\_\_\_



*Kristen Schmidt*  
Kristen Schmidt, Attorney In Fact

# Western Surety Company

## POWER OF ATTORNEY APPOINTING INDIVIDUAL ATTORNEY-IN-FACT

Know All Men By These Presents, That WESTERN SURETY COMPANY, a South Dakota corporation, is a duly organized and existing corporation having its principal office in the City of Sioux Falls, and State of South Dakota, and that it does by virtue of the signature and seal herein affixed hereby make, constitute and appoint

**Kristen Schmidt , Individually**

of Orland Park, IL its true and lawful Attorney(s)-in-Fact with full power and authority hereby conferred to sign, seal and execute for and on its behalf bonds, undertakings and other obligatory instruments of similar nature

**- In Unlimited Amounts -**

Surety Bond No.: 30124766  
Principal: Homer Tree Service, Inc.  
Obligee: City of Lockport

and to bind it thereby as fully and to the same extent as if such instruments were signed by a duly authorized officer of the corporation and all the acts of said Attorney, pursuant to the authority hereby given, are hereby ratified and confirmed.

This Power of Attorney is made and executed pursuant to and by authority of the By-Law printed on the reverse hereof, duly adopted, as indicated, by the shareholders of the corporation.

In Witness Whereof, WESTERN SURETY COMPANY has caused these presents to be signed by its Vice President and its corporate seal to be hereto affixed on this 27th day of February, 2018.



WESTERN SURETY COMPANY

Paul T. Bruflat, Vice President

State of South Dakota }  
County of Minnehaha } ss

On this 27th day of February, 2018, before me personally came Paul T. Bruflat, to me known, who, being by me duly sworn, did depose and say: that he resides in the City of Sioux Falls, State of South Dakota; that he is the Vice President of WESTERN SURETY COMPANY described in and which executed the above instrument; that he knows the seal of said corporation; that the seal affixed to the said instrument is such corporate seal; that it was so affixed pursuant to authority given by the Board of Directors of said corporation and that he signed his name thereto pursuant to like authority, and acknowledges same to be the act and deed of said corporation.

My commission expires

June 23, 2021



J. Mohr, Notary Public

### CERTIFICATE

I, L. Nelson, Assistant Secretary of WESTERN SURETY COMPANY do hereby certify that the Power of Attorney hereinabove set forth is still in force, and further certify that the By-Law of the corporation printed on the reverse hereof is still in force. In testimony whereof I have hereunto subscribed my name and affixed the seal of the said corporation this 29th day of March, 2021.



WESTERN SURETY COMPANY

L. Nelson, Assistant Secretary

Form F4280-7-2012

Go to [www.cnasurety.com](http://www.cnasurety.com) > Owner / Obligee Services > Validate Bond Coverage, if you want to verify bond authenticity.

**Authorizing By-Law**

**ADOPTED BY THE SHAREHOLDERS OF WESTERN SURETY COMPANY**

This Power of Attorney is made and executed pursuant to and by authority of the following By-Law duly adopted by the shareholders of the Company.

Section 7. All bonds, policies, undertakings, Powers of Attorney, or other obligations of the corporation shall be executed in the corporate name of the Company by the President, Secretary, and Assistant Secretary, Treasurer, or any Vice President, or by such other officers as the Board of Directors may authorize. The President, any Vice President, Secretary, any Assistant Secretary, or the Treasurer may appoint Attorneys in Fact or agents who shall have authority to issue bonds, policies, or undertakings in the name of the Company. The corporate seal is not necessary for the validity of any bonds, policies, undertakings, Powers of Attorney or other obligations of the corporation. The signature of any such officer and the corporate seal may be printed by facsimile.



## City Council

### Agenda Memorandum

Item # FN-1

---

**To:** Mayor & City Council

**From:** Lisa Heglund, Finance Director

**Subject:** Bills Through May 9, 2023

**Date:** Wednesday, May 17, 2023

#### **BACKGROUND/HISTORY**

Attached is a list of various bills and invoices through May 9, 2023.

#### **PROS/CONS/ALTERNATIVES**

N/A

#### **RECOMMENDATION**

Approve the various bills through May 9, 2023.

#### **ATTACHMENTS**

[Bill Summary Through May 9, 2023](#)

[Bills List Through May 9, 2023](#)

#### **SPECIFIC CITY COUNCIL ACTION REQUIRED**

Approve the various bills through May 9, 2023 as presented.

**To:** City Council  
**From:** Lisa Heglund  
**RE:** Various Bills  
**Date:** May 9, 2023

Below is a list of some of the invoices that are in your packet. I have included some additional information to further explain the expense. The amounts listed below are based on the invoice amount.

Austin Tyler Construction	797,118.33	2023 Watermain & Roadway Reconstruction Project-April
Baxter and Woodman	5,396.25	Industrial Pretreatment Program Assistance - March/April
Baxter and Woodman	5,818.18	Water And Sewer Rate Study - March
Baxter and Woodman	17,914.10	Regionalization Flow Monitoring Program - March
Baxter and Woodman	41,723.96	Division Street WWTP Improvments Phase I - Mar/April
Baxter and Woodman	200,000.00	Division Street WWTP Improvements Phase II
Bloomington Ford, Inc.	48,302.25	Squad Car
Blue Peak Tents	8,300.00	** Deposit ** Old Canal Days Tent Rentals
BNSF Railway Company	7,633.00	Per Agreement For Resurfacing In Rr Row & Insurance-Tracking # 22W-15764
Chamlin Associates Inc.	5,206.00	FCA Lockport Car Dealership - March
Chamlin Associates Inc.	8,192.00	Gas N Wash - 143Rd & Gougar - March
Chamlin Associates Inc.	12,108.00	State St Lift Station & Water Main - Mary Knoll To 151St Engineering-Feb
Chamlin Associates Inc.	15,318.00	State St Lift Station & Water Main - Mary Knoll To 151St Engineering - March
Chamlin Associates Inc.	16,583.00	Bruce Rd OSs Children's Lift Station Engineering - March
Concentric Integration	9,728.33	Well 10 & 11 PLC Upgrades - March
Conley Excavating, Inc.	14,670.00	Water And Wastewater Structure Adjustments
Core & Main	10,024.00	1 1/2 C2 Flanged Omni Meters
Core & Main	13,627.00	2" C2 Flanged Omni Meters
CPP Events, Inc.	7,842.13	** Deposit ** Old Canal Days - Electricity
DPS Equipment Services, Inc.	45,250.00	Sw Clarifier Repairs Lockport STP
EJ USA, Inc.	22,429.14	Fire Hydrants And Parts
Elliott Electric	10,010.00	Install EV Charger At City Hall
Esri, Inc.	7,719.51	Arcgis Maintenance **Internal Note**
GW & Associates	20,325.00	Audit Fieldwork - April 2023
Heidelberg Materials Midwest Agg	5,961.11	20 Loads of Ca-6 To Chevron
Meade Inc.	5,479.58	Repair 9th St Bridge Streetlights
New Era Spreading Inc	33,930.00	Sludge Haul from BBFM-April
Treasurer, State Of Illinois	139,833.92	2022 Streetscape Cost Share
Twig Technologies	6,891.25	GIS IT & Maintenance - March
United Door & Lock	6,800.00	Repair Of Door For Sally Port
Wescom	35,371.03	Monthly Dispatch Fee, Airtime Fees - June
Wescom	35,610.98	Dispatch Service, Airtime Fees - April 2023
West Side Specialized Service	12,700.00	Light Tower/Generator **2023**
West Side Specialized Service	33,613.68	Purchase Of A New 2022 Felling Ft-30-2 Tilt Trailer
Williams Brothers Construction	255,431.79	Division Street WWTP Improvements Phase III
Xylem Water Solutions USA, Inc	111,864.61	Flygt Submersible Pumps For Briggs St. Lift Station Project

INVOICE REGISTER FOR CITY OF LOCKPORT  
 EXP CHECK RUN DATES 04/26/2023 - 05/09/2023  
 JOURNALIZED  
 PAID

VENDOR NAME	INVOICE NUMBER	INVOICE DATE	DESCRIPTION	ACCOUNT #	DEPARTMENT	ITEM AMOUNT
<b>3 CORNERS GRILL &amp; TAP</b>						
	340072	04/30/2023	P.D. #75 UNION MEETING - NEYHART, BENSON	01-01-00-56800	CITY ADMINISTRATION	\$61.72
					<b>VENDOR TOTAL:</b>	<b>\$61.72</b>
<b>A &amp; W TRAILER LLC</b>						
	7708	04/29/2023	#163 - DRUMS AND BRAKES	01-18-00-52200	STREET DEPARTMENT	\$779.92
					<b>VENDOR TOTAL:</b>	<b>\$779.92</b>
<b>ACCURATE EMPLOYMENT SCREENINGS LLC</b>						
	AUR2166148	04/30/2023	EMPLOYMENT SCREENING - DIAZ, FITZPATRICK	01-18-00-52820	STREET DEPARTMENT	\$144.84
					<b>VENDOR TOTAL:</b>	<b>\$144.84</b>
<b>ADOBE</b>						
	3/30/2023	04/28/2023	ADOBE ACROPRO SUBS	01-01-00-53600	CITY ADMINISTRATION	\$15.93
					<b>VENDOR TOTAL:</b>	<b>\$15.93</b>
<b>ADVANTAGE BUILDING CORP</b>						
	05/01/2023	04/29/2023	UB refund for account: 0048020500-00	20-00-00-12500	CTY ADMIN OR CPTL OUTLY	\$33.67
					<b>VENDOR TOTAL:</b>	<b>\$33.67</b>
<b>AIR WANS</b>						
	178756	05/09/2023	ANNUAL INTERNET SERVICE FOR PUBLIC WORKS-I	01-01-00-53600	CITY ADMINISTRATION	\$259.00
					<b>VENDOR TOTAL:</b>	<b>\$259.00</b>
<b>AMAZON CAPITAL SERVICES</b>						
	1TLF-1GQ3-MHFM	04/30/2023	AA BATTERIES, C BATTERIES	01-16-00-51000	PUBLIC WORKS	\$52.04
	1HN4-DH3G-NJJ6	04/30/2023	BLACK VINYL CHAIR, MINI CASE BOX, GPS TRACKER	01-04-00-51670	POLICE DEPARTMENT	\$381.60
	1PJR-VRJ7-PFFR	04/30/2023	PORTABLE CHARGER POWER BANK, PORTABLE CH	01-16-00-51000	PUBLIC WORKS	\$59.58
	199M-DFKX-KVNR	04/30/2023	K CUP HOLDERS, IPHONE CHARGER, BREWER STA	01-04-00-56800	POLICE DEPARTMENT	\$228.32
	191W-1P3H-M3RY	04/30/2023	FOAM GLOW STICKS - ILLUMINATE EVENT	01-01-00-56310	CITY ADMINISTRATION	\$206.99
	1MRK-QYG7-LDLK	04/30/2023	MIC ENABLED WEBCAM	01-16-00-51000	PUBLIC WORKS	\$63.40
	1XKY-HM7K-MJ9R	04/30/2023	FULL HD MONITOR, CABPE ADAPTER CONVERTER	01-01-00-53400	CITY ADMINISTRATION	\$1,278.88
					<b>VENDOR TOTAL:</b>	<b>\$2,270.81</b>
<b>AMAZON, INC.</b>						
	114-1661765-000905	04/28/2023	DUST OFF	01-16-00-51000	PUBLIC WORKS	\$29.99
					<b>VENDOR TOTAL:</b>	<b>\$29.99</b>
<b>AMERICAN LEGAL PUBLISHING CORP</b>						
	25130	04/30/2023	APRIL 2023 S-34 EDITING	01-01-00-52600	CITY ADMINISTRATION	\$176.00
					<b>VENDOR TOTAL:</b>	<b>\$176.00</b>
<b>ANGLE DRONE SOLUTIONS INC.</b>						
	ILLUMINATE PREMIE	04/28/2023	3.30.23 DRONE FOOTAGE FOR ILLUMINATE VIP NIGI	01-01-00-56310	CITY ADMINISTRATION	\$150.00
					<b>VENDOR TOTAL:</b>	<b>\$150.00</b>
<b>ANYPROMO.COM</b>						

INVOICE REGISTER FOR CITY OF LOCKPORT  
 EXP CHECK RUN DATES 04/26/2023 - 05/09/2023  
 JOURNALIZED  
 PAID

VENDOR NAME	INVOICE NUMBER	INVOICE DATE	DESCRIPTION	ACCOUNT #	DEPARTMENT	ITEM AMOUNT
	CV3045212	04/30/2023	FLYER DISC	01-04-00-56300	POLICE DEPARTMENT	\$300.22
	CV30311281	04/30/2023	BADGES FOR SCHOOLS	01-04-00-51000	POLICE DEPARTMENT	\$347.31
					<b>VENDOR TOTAL:</b>	<b>\$647.53</b>
APWA-CHICAGO METRO CHAPTER						
	129802	04/28/2023	REGISTRATION-REQUIRED IL STATUTES AND RULE	01-09-00-56200	ENGINEERING	\$20.00
	129803	04/28/2023	APWA REGISTRATION -IL PROFESSIONAL ETHICS- E	01-09-00-56200	ENGINEERING	\$20.00
					<b>VENDOR TOTAL:</b>	<b>\$40.00</b>
ARTHUR J. GALLAGHER & CO.						
	4670472	04/29/2023	2023 GENERAC LIGHT PLANT	01-01-00-54000	CITY ADMINISTRATION	\$16.00
					<b>VENDOR TOTAL:</b>	<b>\$16.00</b>
AUSTIN TYLER CONSTRUCTION LLC						
	2306-02	04/30/2023	2023 WATERMAIN & ROADWAY RECONSTRUCTION	14-00-00-52311	CTY ADMIN OR CPTL OUTLY	\$797,118.33
					<b>VENDOR TOTAL:</b>	<b>\$797,118.33</b>
BAXTER AND WOODMAN, INC						
	244707	04/30/2023	PFAS IMPACT REPORT - JAN	20-15-00-53200	PUBLIC WORKS	\$32.75
	244710	04/30/2023	2022 PRETREATMENT ASSISTANCE PH II - FEB	20-16-00-53200	PUBLIC WORKS	\$1,655.00
	244708	04/30/2023	SOURCE WATER PROTECTION PLAN - FEB	20-24-00-67000	WATER/SEWER CAPITAL	\$2,852.50
	245683	04/30/2023	DIVISION STREET WWTP IMPROVEMENTS PHASE II	20-24-00-67000	WATER/SEWER CAPITAL	\$200,000.00
	245684	04/30/2023	LOCKPORT HEIGHTS WATER INFRASTRUCTURE AS	20-15-00-53200	PUBLIC WORKS	\$11.67
	245691	04/30/2023	ADAMS ST HEADWALL & RAILING REPAIR - APRIL	14-00-00-53200	CTY ADMIN OR CPTL OUTLY	\$3,065.00
	245690	04/30/2023	151ST ST LIFT STATION STUDY - MARCH	01-09-00-53200	ENGINEERING	\$41.25
	245679	04/30/2023	WATER AND SEWER RATE STUDY - MARCH	20-15-00-53200	PUBLIC WORKS	\$5,818.18
	245685	04/30/2023	INDUSTRIAL PRETREATMENT PROGRAM ASSISTAN	20-16-00-53200	PUBLIC WORKS	\$5,396.25
	245682	04/30/2023	PFAS IMPACT REPORT - MAR/APRIL	20-15-00-53200	PUBLIC WORKS	\$1,363.75
	245692	04/30/2023	REGIONALIZATION FLOW MONITORING PROGRAM -	20-24-00-67000	WATER/SEWER CAPITAL	\$17,914.10
	245681	04/30/2023	DIVISION STREET WWTP IMPROVMENTS PHASE I - I	20-24-00-67000	WATER/SEWER CAPITAL	\$41,723.96
					<b>VENDOR TOTAL:</b>	<b>\$279,874.41</b>
BEARY LANDSCAPE MANAGEMENT INC						
	254537	04/30/2023	RESTORATIONS @ 309 LAURIE - MAIN BREAK	20-15-00-52260	PUBLIC WORKS	\$1,410.00
					<b>VENDOR TOTAL:</b>	<b>\$1,410.00</b>
BEST BUY #308						
	BBY01-80675472949	04/30/2023	PORTABLE PROJECTOR SCREEN	01-01-00-51000	CITY ADMINISTRATION	\$149.99
					<b>VENDOR TOTAL:</b>	<b>\$149.99</b>
BLOOMINGTON FORD, INC.						
	STOCK #FE2202	04/26/2023	SQUAD CAR	14-00-00-59530	CTY ADMIN OR CPTL OUTLY	\$48,302.25
					<b>VENDOR TOTAL:</b>	<b>\$48,302.25</b>
BLUE COLLAR SUPPLY						
	26198	05/09/2023	UNIFORM ALLOWANCE FOR L. GASPER	01-18-00-51600	STREET DEPARTMENT	\$129.00

INVOICE REGISTER FOR CITY OF LOCKPORT  
 EXP CHECK RUN DATES 04/26/2023 - 05/09/2023  
 JOURNALIZED  
 PAID

VENDOR NAME	INVOICE NUMBER	INVOICE DATE	DESCRIPTION	ACCOUNT #	DEPARTMENT	ITEM AMOUNT
<b>VENDOR TOTAL:</b>						<b>\$129.17</b>
BLUE PEAK TENTS	113062	05/03/2023	** DEPOSIT ** OLD CANAL DAYS TENT RENTALS	01-20-00-52200	SPECIAL PROJECTS	\$8,300.00
<b>VENDOR TOTAL:</b>						<b>\$8,300.00</b>
BNSF RAILWAY COMPANY	TRACKING #22W-15	04/28/2023	PER AGREEMENT FOR RESURFACING IN RR ROW &	14-00-00-52311	CTY ADMIN OR CPTL OUTLY	\$7,633.00
	90249711	04/30/2023	ENGINEERING SERVICES AREEMENT FOR QUIET ZC	14-00-00-53200	CTY ADMIN OR CPTL OUTLY	\$1,374.67
<b>VENDOR TOTAL:</b>						<b>\$9,007.67</b>
BONNIE BRAE FOREST MANOR	MAY 2023	05/01/2023	MONTHLY CONTRIBUTION- MAY 2023	20-15-00-56920	PUBLIC WORKS	\$20,801.09
<b>VENDOR TOTAL:</b>						<b>\$20,801.09</b>
BROWN TECHNOLOGIES, LLC	MAY 2023	05/01/2023	INETERNET SERVICE@SCALEHOUSE-200 W 10TH S	01-01-00-53600	CITY ADMINISTRATION	\$100.00
	SPEAKER SYSTEM	04/29/2023	SPEAKER INSTALLATION AT SCALE HOUSE- ILLUMII	01-01-00-56310	CITY ADMINISTRATION	\$475.00
<b>VENDOR TOTAL:</b>						<b>\$575.00</b>
BS & A SOFTWARE	146233	05/01/2023	ANNUAL SERVICE/SUPPORT FEE- 5/1/2023-5/1/2024	01-01-00-53600	CITY ADMINISTRATION	\$2,683.00
<b>VENDOR TOTAL:</b>						<b>\$2,683.00</b>
BURRIS EQUIPMENT CO.	PS30136137-2	04/28/2023	STREET DEPT CHAIN SAW PARTS	01-18-00-52200	STREET DEPARTMENT	\$322.91
	PS3013137-1	04/29/2023	BLADES FOR MOWERS, CHAINS FOR CHAIN SAWS	01-18-00-52200	STREET DEPARTMENT	\$1,370.81
	PS3013137-3	05/09/2023	FILTERS FOR MOWERS	01-18-00-52200	STREET DEPARTMENT	\$219.92
	PS3013270-1	05/09/2023	#55/#611-LOWER RADIATOR HOSES	01-18-00-52200	STREET DEPARTMENT	\$39.94
<b>VENDOR TOTAL:</b>						<b>\$1,953.58</b>
CAFE MOXO	764282	04/30/2023	WILL COUNTY GOVERNMENT LEAGUE - MAYOR, BE	01-01-00-56800	CITY ADMINISTRATION	\$29.63
<b>VENDOR TOTAL:</b>						<b>\$29.63</b>
CANON FINANCIAL SERVICES, INC.	30183419	04/28/2023	COPIER RENTAL@CITY HALL, STP, PW - FEB	01-01-00-55000	CITY ADMINISTRATION	\$1,981.39
	30349342	04/30/2023	COPIER RENTAL@CITY HALL, STP, PW - MARCH	01-01-00-55000	CITY ADMINISTRATION	\$1,287.90
<b>VENDOR TOTAL:</b>						<b>\$3,269.29</b>
CAR REFLECTIONS	23-67	05/09/2023	510 SQUAD STRIPE AND GRAPHICS	01-04-00-51670	POLICE DEPARTMENT	\$1,095.00
<b>VENDOR TOTAL:</b>						<b>\$1,095.00</b>
CARGILL, INCORPORATED	2908045479	04/30/2023	800 TONS ROAD SALT - ORDER 1	02-00-00-52440	CTY ADMIN OR CPTL OUTLY	\$65,175.11
<b>VENDOR TOTAL:</b>						<b>\$65,175.11</b>

INVOICE REGISTER FOR CITY OF LOCKPORT  
 EXP CHECK RUN DATES 04/26/2023 - 05/09/2023  
 JOURNALIZED  
 PAID

VENDOR NAME	INVOICE NUMBER	INVOICE DATE	DESCRIPTION	ACCOUNT #	DEPARTMENT	ITEM AMOUNT
-----						
CARLIN SALES CORP.	5008084-00	04/30/2023	PREEMERGENT, HERBICIDE, ETC. FOR DOWNTOWN	01-18-00-56810	STREET DEPARTMENT	\$205.06
					<b>VENDOR TOTAL:</b>	<b>\$205.06</b>
CENTRAL STATES WATER ENVIRONMENT	9067324A8548847	04/28/2023	REGISTRATION-CSWEA - J NEIGHBORS	20-16-00-56200	PUBLIC WORKS	\$515.00
					<b>VENDOR TOTAL:</b>	<b>\$515.00</b>
CHAMLIN ASSOCIATES INC.	3023199	04/30/2023	STATE ST LIFT STATION & WATER MAIN - MARY KN	20-24-00-67000	WATER/SEWER CAPITAL	\$12,108.00
	3023193	04/30/2023	CAR WASH SEC OF 4TH AND STATE - FEB	01-09-00-53200	ENGINEERING	\$444.00
	3023189	04/30/2023	GAS N WASH - 143RD & GOUGAR - FEB	01-09-00-53200	ENGINEERING	\$296.00
	3023185	04/30/2023	SERENITY LANDING - FEB	01-09-00-53200	ENGINEERING	\$296.00
	3023178	04/30/2023	REDWOOD APARTMENT HOMES - FEB	01-09-00-53200	ENGINEERING	\$622.00
	3023191	04/30/2023	WILL COUNTY SCHOOL SITEWORK 2023 - FEB	01-09-00-53200	ENGINEERING	\$1,776.00
	3023192	04/30/2023	PRIME SUB LOTS 9-11 - FEB	01-09-00-53200	ENGINEERING	\$450.00
	3023190	04/30/2023	GAS STATION - 151ST AND ARCHER - FEB	01-09-00-53200	ENGINEERING	\$888.00
	3023183	04/30/2023	HOMER TREE SERVICE - ARCHER EXPANSION - FE	01-09-00-53200	ENGINEERING	\$148.00
	3023186	04/30/2023	WENDYS/NOODLES/CRUMBL @ LOCKPORT SQUARE	01-09-00-53200	ENGINEERING	\$592.00
	3023267	04/30/2023	PROLOGIS PARK PLAN REVIEW - MARCH	01-09-00-53200	ENGINEERING	\$2,898.50
	3023268	04/30/2023	GRADING - LAGO VISTA PH 5 - MARCH	01-09-00-53200	ENGINEERING	\$592.00
	3023270	04/30/2023	FCA LOCKPORT CAR DEALERSHIP - MARCH	01-09-00-53200	ENGINEERING	\$5,206.00
	3023271	04/30/2023	PROLOGIS BUILDING 6 - MARCH	01-09-00-53200	ENGINEERING	\$2,039.50
	3023272	04/30/2023	PROLOGIS BUILDING 7 - MARCH	01-09-00-53200	ENGINEERING	\$2,226.50
	3023273	04/30/2023	GRADING - CLOVER RIDGE PH3 - MARCH	01-09-00-53200	ENGINEERING	\$592.00
	3023275	04/30/2023	GRADING - PARKSIDE ESTATES PH2-MARCH	01-09-00-53200	ENGINEERING	\$74.00
	3023277	04/30/2023	GRADING - REDWOOD APTS - MARCH	01-09-00-53200	ENGINEERING	\$1,200.50
	3023279	04/30/2023	GRADING - OAK CREEK PH 3 - MARCH	01-09-00-53200	ENGINEERING	\$74.00
	3023281	04/30/2023	SILO BEND - MARCH	01-09-00-53200	ENGINEERING	\$4,286.50
	3023284	04/30/2023	PROLOGIS BUILDING 4 FINAL PLANS - MARCH	01-09-00-53200	ENGINEERING	\$1,001.00
	3023286	04/30/2023	RUSH THE PUCK/SUMMIT HOCKEY DOME - MARCH	01-09-00-53200	ENGINEERING	\$370.00
	3023287	04/30/2023	LOCKPORT SQUARE LOT 18 - LIFE STORAGE - MAR	01-09-00-53200	ENGINEERING	\$740.00
	3023288	04/30/2023	ROSE CENTER- FARRELL ROAD - MARCH	01-09-00-53200	ENGINEERING	\$1,480.00
	3023289	04/30/2023	GRADING - 1423 JOHNSON - STREET GRADING PLA	01-09-00-53200	ENGINEERING	\$113.00
	3023290	04/30/2023	GAS N WASH - 143RD & GOUGAR - MARCH	01-09-00-53200	ENGINEERING	\$8,192.00
	3023292	04/30/2023	PANDA EXPRESS AT ROSE CENTER - MARCH	01-09-00-53200	ENGINEERING	\$2,516.00
	3023298	04/30/2023	STATE ST LIFT STATION & WATER MAIN - MARY KN	20-24-00-67000	WATER/SEWER CAPITAL	\$15,318.00
	3023296	04/30/2023	BRUCE RD SOS CHILDREN'S LIFT STATION ENGINEE	20-24-00-67000	WATER/SEWER CAPITAL	\$16,583.00
	3023280	04/30/2023	GRADING - SILO BEND SUBDIVISION - MARCH	01-09-00-53200	ENGINEERING	\$1,628.00
	3023297	04/30/2023	LEAD WATER SERVICE LINE REPLACEMENT - MARC	01-09-00-53200	ENGINEERING	\$480.00
					<b>VENDOR TOTAL:</b>	<b>\$85,230.50</b>

INVOICE REGISTER FOR CITY OF LOCKPORT  
 EXP CHECK RUN DATES 04/26/2023 - 05/09/2023  
 JOURNALIZED  
 PAID

VENDOR NAME	INVOICE NUMBER	INVOICE DATE	DESCRIPTION	ACCOUNT #	DEPARTMENT	ITEM AMOUNT
	4/3/2023	04/28/2023	CHICAGO TRIBUNE SUBSCRIPTION	01-09-00-51400	ENGINEERING	\$23.96
	3/24/2023	04/30/2023	CHICAGO TRIBUNE	01-01-00-51400	CITY ADMINISTRATION	\$19.96
					<b>VENDOR TOTAL:</b>	<b>\$43.92</b>
CHRISTOPHER B. BURKE ENG., LTD.	182840	04/30/2023	IL 7 CHANNELIZATION PHASE II ENGINEERING SER\	14-00-00-53200	CTY ADMIN OR CPTL OUTLY	\$1,260.23
					<b>VENDOR TOTAL:</b>	<b>\$1,260.23</b>
CINTAS	840623890	04/30/2023	MONTHLY MEDICAL CABINET CHECK	20-16-00-52800	PUBLIC WORKS	\$24.34
					<b>VENDOR TOTAL:</b>	<b>\$24.34</b>
CINTAS CORP	4137052386	04/30/2023	HAND SANITIZER STAND CONTRACT - FINAL INVOIC	01-01-00-52800	CITY ADMINISTRATION	\$75.89
					<b>VENDOR TOTAL:</b>	<b>\$75.89</b>
CINTAS CORP	4142607695	04/30/2023	HAND SANITIZERSTAND CONTRACT - FINAL INVOIC	01-01-00-52800	CITY ADMINISTRATION	\$75.89
					<b>VENDOR TOTAL:</b>	<b>\$75.89</b>
CLARK LANHAM	STATE OF STATE	04/30/2023	STATE OF THE CITY ADDRESS LIVE STREAMING	01-01-00-56301	CITY ADMINISTRATION	\$1,600.00
					<b>VENDOR TOTAL:</b>	<b>\$1,600.00</b>
CLASSIC CAR WASH	959	04/28/2023	CAR WASH - B CANN	01-09-00-52000	ENGINEERING	\$15.00
					<b>VENDOR TOTAL:</b>	<b>\$15.00</b>
COLONY HARDWARE CORP	1568342	04/30/2023	PARTS FOR INFLUENT WATER LINE	20-24-00-67100	WATER/SEWER CAPITAL	\$4,330.19
					<b>VENDOR TOTAL:</b>	<b>\$4,330.19</b>
COM ED	2203107039-89	04/30/2023	TRAFFIC SIGNAL - APRIL	01-18-00-53700	STREET DEPARTMENT	\$184.45
	6771073142-R	04/30/2023	304 W 5TH STREET - CHEVRON - APRIL	01-01-00-52705	CITY ADMINISTRATION	\$825.74
	0402116036-2	04/30/2023	WELL 15 - APRIL	20-15-00-53700	PUBLIC WORKS	\$4,264.21
					<b>VENDOR TOTAL:</b>	<b>\$5,274.40</b>
COMCAST	170948245	04/28/2023	ETHERNET SERVICE@P.W. CITY HALL, P.D. - APRIL	01-01-00-53600	CITY ADMINISTRATION	\$3,958.18
					<b>VENDOR TOTAL:</b>	<b>\$3,958.18</b>
COMCAST CABLE		INTERNET SERVICE 04/28/2023	INTERNET SERVICE@ TRAIN STATION	01-01-00-53600	CITY ADMINISTRATION	\$182.90
		INTERNET SVC @ S' 04/28/2023	INTERNET SERVICE@STP	01-01-00-53600	CITY ADMINISTRATION	\$253.70
		INTERNET SVC 04/28/2023	INTERNET SERVICE@P.D.	01-01-00-53600	CITY ADMINISTRATION	\$605.22
		INTERNET/CITY HAL 04/30/2023	INTERNET@CITY HALL - APRIL	01-01-00-53600	CITY ADMINISTRATION	\$686.70

INVOICE REGISTER FOR CITY OF LOCKPORT  
 EXP CHECK RUN DATES 04/26/2023 - 05/09/2023  
 JOURNALIZED  
 PAID

VENDOR NAME	INVOICE NUMBER	INVOICE DATE	DESCRIPTION	ACCOUNT #	DEPARTMENT	ITEM AMOUNT	
						<b>VENDOR TOTAL:</b>	<b>\$1,728.52</b>
COMPUTERS NATIONWIDE							
	IL-24768	04/30/2023	CARD READER REPAIR FOR EMPLOYEE DOOR	01-16-00-68000	PUBLIC WORKS	\$892.00	
						<b>VENDOR TOTAL:</b>	<b>\$892.00</b>
CONCENTRIC INTEGRATION, LLC							
	245688	04/30/2023	2023 YEARLY SCADA MANAGEMENT PROGRAM	20-24-00-67000	WATER/SEWER CAPITAL	\$1,605.78	
	245689	04/30/2023	2023 YEARLY SCADA MANAGEMENT PROGRAM	20-24-00-67000	WATER/SEWER CAPITAL	\$1,434.11	
	245680	04/30/2023	WELL 10 & 11 PLC UPGRADES - MARCH	20-24-00-67000	WATER/SEWER CAPITAL	\$9,728.33	
						<b>VENDOR TOTAL:</b>	<b>\$12,768.22</b>
CONLEY EXCAVATING, INC.							
	4663	04/30/2023	WATER AND WASTEWATER STRUCTURE ADJUSTM	20-16-00-52260	PUBLIC WORKS	\$14,670.00	
	4664	04/30/2023	WATER AND WASTEWATER STRUCTURE ADJUSTM	20-15-00-52260	PUBLIC WORKS	\$1,577.00	
						<b>VENDOR TOTAL:</b>	<b>\$16,247.00</b>
CONSTELLATION NEW ENERGY, INC.							
	63878687502	04/30/2023	MONTHLY ELECTRIC@BOOSTER, LIFT STATIONS, W	20-16-00-53700	PUBLIC WORKS	\$56,106.61	
	64469149801	04/30/2023	ELECTRIC-LIFT STATIONS, PRV 'S - FEB	20-16-00-53700	PUBLIC WORKS	\$1,762.85	
						<b>VENDOR TOTAL:</b>	<b>\$57,869.46</b>
COOM'S CORNER							
	432429	04/30/2023	PZC RECOGNITION - D DESKIN	01-01-00-56800	CITY ADMINISTRATION	\$50.00	
						<b>VENDOR TOTAL:</b>	<b>\$50.00</b>
CORE & MAIN							
	S660166	04/30/2023	2" C2 FLANGED OMNI METERS	20-15-00-52230	PUBLIC WORKS	\$13,627.00	
	S660184	04/30/2023	1 1/2 C2 FLANGED OMNI METERS	20-15-00-52230	PUBLIC WORKS	\$10,024.00	
						<b>VENDOR TOTAL:</b>	<b>\$23,651.00</b>
COSTAR REALTY INFORMATION, INC.							
	120317918	04/30/2023	MONTHLY SITE RESEARCH- APRIL 2023	01-07-00-53200	PLANNING/ECONOMIC DEV	\$466.56	
						<b>VENDOR TOTAL:</b>	<b>\$466.56</b>
COSTCO WHOLESALE							
	965175	04/28/2023	CASES OF WATER / VINEGAR	01-04-00-56800	POLICE DEPARTMENT	\$39.00	
						<b>VENDOR TOTAL:</b>	<b>\$39.00</b>
CPP EVENTS, INC.							
	* DEPOSIT * OCD 20:04/28/2023		** DEPOSIT ** OLD CANAL DAYS - ELECTRICITY	01-20-00-52200	SPECIAL PROJECTS	\$7,842.13	
						<b>VENDOR TOTAL:</b>	<b>\$7,842.13</b>
CPS-WHEELING							
	3-0055245	04/30/2023	12 OIL FILTERS FOR PD	01-04-00-52000	POLICE DEPARTMENT	\$64.80	
						<b>VENDOR TOTAL:</b>	<b>\$64.80</b>
CRESCENT ELECTRIC SUPPLY CO.							

INVOICE REGISTER FOR CITY OF LOCKPORT  
 EXP CHECK RUN DATES 04/26/2023 - 05/09/2023  
 JOURNALIZED  
 PAID

VENDOR NAME	INVOICE NUMBER	INVOICE DATE	DESCRIPTION	ACCOUNT #	DEPARTMENT	ITEM AMOUNT
	S511335022.001	05/09/2023	ITEMS FOR STREETLIGHTS - PHOTOCONTROL	01-18-00-52210	STREET DEPARTMENT	\$439.62
					<b>VENDOR TOTAL:</b>	<b>\$439.62</b>
CROSS POINTS SALES, INC.						
	P 80605	05/09/2023	ANNUAL FIRE ALARM TEST & INSPECTION SERVICE	01-03-00-52020	COMMUTER LOT	\$167.00
	P 80606	04/30/2023	ANNUAL FIRE ALARM TEST & SPRINKLER INSEPCTI	01-16-00-52100	PUBLIC WORKS	\$831.50
					<b>VENDOR TOTAL:</b>	<b>\$998.50</b>
CROWNE PLAZA						
	28012865	04/28/2023	WATERCON 23-REGISTRATION - W RYAN	20-15-00-56200	PUBLIC WORKS	\$461.70
	25322375	04/28/2023	WATERCON 23-REGISTRATION - D WYSOCKI	01-18-00-56200	STREET DEPARTMENT	\$461.70
					<b>VENDOR TOTAL:</b>	<b>\$923.40</b>
CUMMINS, INC						
	F2-27158	04/28/2023	GENERATOR FOR STATION	01-04-00-52200	POLICE DEPARTMENT	\$689.19
					<b>VENDOR TOTAL:</b>	<b>\$689.19</b>
DALE TOLLY REMODELING						
	674	04/30/2023	KITCHEN CABINETS	01-04-00-52100	POLICE DEPARTMENT	\$468.00
					<b>VENDOR TOTAL:</b>	<b>\$468.00</b>
DELLWOOD TIRE & AUTO						
	2-GS65105	04/28/2023	#549 - 4 TIRES	01-04-00-52000	POLICE DEPARTMENT	\$704.80
	2-GS65153	05/09/2023	#506 - 4 TIRES	01-04-00-52000	POLICE DEPARTMENT	\$715.20
	2-GS65156	05/09/2023	#706 - 2 TIRES, 2 VAVLES, & 2 BALANCE BEADS	20-15-00-52200	PUBLIC WORKS	\$661.10
	2-GS65165	05/09/2023	#511- TIRES	01-04-00-52000	POLICE DEPARTMENT	\$176.20
					<b>VENDOR TOTAL:</b>	<b>\$2,257.30</b>
DONNA NEVELS						
	ILLUMINATE	04/28/2023	ILLUMINATE 3/30/2023	01-01-00-56310	CITY ADMINISTRATION	\$50.00
	APRIL	04/28/2023	SPECIAL EVENT COORD - APRIL 2023	01-01-00-56310	CITY ADMINISTRATION	\$650.00
					<b>VENDOR TOTAL:</b>	<b>\$700.00</b>
DOUBLETREE AB LINCOLN						
	85223387	04/30/2023	WCGL - HOTEL - MAYOR	01-01-00-56200	CITY ADMINISTRATION	\$279.21
					<b>VENDOR TOTAL:</b>	<b>\$279.21</b>
DPS EQUIPMENT SERVICES, INC.						
	PAY APP #1	04/30/2023	SW CLARIFIER REPAIRS LOCKPORT STP	20-24-00-67250	WATER/SEWER CAPITAL	\$45,250.00
					<b>VENDOR TOTAL:</b>	<b>\$45,250.00</b>
EDUCATION & OUTREACH COMPANY						
	23-390	04/29/2023	PW EDUCATION ITEMS FOR YOUTH	01-18-00-51300	STREET DEPARTMENT	\$1,520.00
					<b>VENDOR TOTAL:</b>	<b>\$1,520.00</b>
EDWARD J. BATIS & ASSOCIATES						
	723 S STATE ST	04/28/2023	APPRAISAL FOR 723 SOIUTH STATE	01-01-00-53200	CITY ADMINISTRATION	\$1,750.00

INVOICE REGISTER FOR CITY OF LOCKPORT  
 EXP CHECK RUN DATES 04/26/2023 - 05/09/2023  
 JOURNALIZED  
 PAID

VENDOR NAME	INVOICE NUMBER	INVOICE DATE	DESCRIPTION	ACCOUNT #	DEPARTMENT	ITEM AMOUNT	
						<b>VENDOR TOTAL:</b>	<b>\$1,750.00</b>
EJ USA, INC.							
	110230023866	04/28/2023	FIRE HYDRANTS AND PARTS	20-15-00-52260	PUBLIC WORKS	\$22,429.14	
						<b>VENDOR TOTAL:</b>	<b>\$22,429.14</b>
ELLIOTT ELECTRIC							
	27785	04/28/2023	CONCRETE PAD FOR NORTH GENERATOR	20-16-00-52200	PUBLIC WORKS	\$4,800.00	
	27805	05/09/2023	INSTALL EV CHARGER AT CITY HALL	01-01-00-53000	CITY ADMINISTRATION	\$10,010.00	
						<b>VENDOR TOTAL:</b>	<b>\$14,810.00</b>
ESRI, INC.							
	94471038	04/28/2023	ARCGIS MAINTENANCE **INTERNAL NOTE**	01-01-00-53600	CITY ADMINISTRATION	\$7,719.51	
						<b>VENDOR TOTAL:</b>	<b>\$7,719.51</b>
FAB WERKS INC.							
	51073	04/30/2023	TABLE FOR CONF ROOM	01-04-00-52100	POLICE DEPARTMENT	\$3,250.00	
						<b>VENDOR TOTAL:</b>	<b>\$3,250.00</b>
FACEBOOK							
	QNH9YMKNJ2	04/30/2023	CAMPAIGNS-RESTAURANT WEEK	01-01-00-56301	CITY ADMINISTRATION	\$32.61	
						<b>VENDOR TOTAL:</b>	<b>\$32.61</b>
FERGUSON ENTERPRISES LLC #3099							
	232578	04/30/2023	SPIKES FOR CHLORINATOR	20-15-00-52220	PUBLIC WORKS	\$721.09	
	234530	04/30/2023	LOCATOR REPAIR	20-15-00-52260	PUBLIC WORKS	\$810.40	
						<b>VENDOR TOTAL:</b>	<b>\$1,531.49</b>
FISHER AUTO PARTS, INC.							
	341-072596	04/28/2023	#503 - AIR FILTER, WIPER BLADES	01-04-00-52000	POLICE DEPARTMENT	\$54.50	
	341-072600	04/28/2023	#523 - AIR FILTER	01-04-00-52000	POLICE DEPARTMENT	\$12.17	
	341-072551	04/28/2023	#556 - WIPER BLADES	01-04-00-52000	POLICE DEPARTMENT	\$30.98	
	341-072506	04/28/2023	#525 - WIPER BLADES	01-04-00-52000	POLICE DEPARTMENT	\$44.73	
	341-072691	04/28/2023	#609 - OIL, FUEL FILTER	20-16-00-52000	PUBLIC WORKS	\$13.60	
	341-072745	04/28/2023	#513 - WIPER BLADES	01-04-00-52000	POLICE DEPARTMENT	\$44.13	
	341-072985	05/09/2023	#701 - AIR FILTER	20-15-00-52000	PUBLIC WORKS	\$16.23	
	341-072982	05/09/2023	#701/#707 - WIPER BLADES	20-15-00-52000	PUBLIC WORKS	\$60.56	
	341-072988	05/09/2023	#704 - AIR FILTER	20-15-00-52000	PUBLIC WORKS	\$34.18	
	341-072994	05/09/2023	#707 - SET FRONT BRAKE PADS	20-15-00-52000	PUBLIC WORKS	\$86.54	
						<b>VENDOR TOTAL:</b>	<b>\$397.62</b>
FLEET SAFETY SUPPLY							
	80677	04/28/2023	SELECT A FLASH ISOLATION, CONTROL PANEL ANE	01-04-00-52000	POLICE DEPARTMENT	\$292.31	
						<b>VENDOR TOTAL:</b>	<b>\$292.31</b>
GALLAGHER MATERIALS, INC.							
	27553	04/28/2023	SEMI LOAD OF COLD PATCH - APRIL	01-18-00-52310	STREET DEPARTMENT	\$3,589.	

INVOICE REGISTER FOR CITY OF LOCKPORT  
 EXP CHECK RUN DATES 04/26/2023 - 05/09/2023  
 JOURNALIZED  
 PAID

VENDOR NAME	INVOICE NUMBER	INVOICE DATE	DESCRIPTION	ACCOUNT #	DEPARTMENT	ITEM AMOUNT
						<b>VENDOR TOTAL:</b>
						<b>\$3,589.41</b>
<b>GENUINE PARTS COMPANY</b>						
	3104-796508	04/28/2023	#609 - OIL FILTER	20-16-00-52000	PUBLIC WORKS	\$8.61
	3104-796503	04/28/2023	#612 - LOWER RADIATOR HOSE	20-16-00-52000	PUBLIC WORKS	\$138.54
	3104-796321	04/28/2023	SHOP - 2 CANS PENETRATING OIL - WD40	01-15-00-51500	PUBLIC WORKS	\$15.98
	3104-796178	04/28/2023	OZZY JUICE FOR PARTS WASHER & FILTER MAT	01-15-00-51900	PUBLIC WORKS	\$126.98
	3104-796156	04/28/2023	#709 - GAS CAP	20-15-00-52200	PUBLIC WORKS	\$27.13
	3104-796154	04/28/2023	#604- MARKER LIGHT	20-16-00-52000	PUBLIC WORKS	\$14.10
	3104-796425	04/28/2023	#549 - REAR BRAKE ROTORS	01-04-00-52000	POLICE DEPARTMENT	\$157.00
	3104-796414	04/28/2023	#612 - LOWER RADIATOR HOSES	20-16-00-52200	PUBLIC WORKS	\$229.48
	3104-796430	04/28/2023	#609 - AIR FILTER	20-16-00-52000	PUBLIC WORKS	\$58.66
	3104-796726	04/29/2023	#SHOP -UTILITY KNIFE BLADES	01-15-00-51900	PUBLIC WORKS	\$9.86
	3104-796529	04/30/2023	* CREDIT * #616-RAD. HOSE-ORIGINAL INVOICE #310	20-16-00-52200	PUBLIC WORKS	\$(138.54)
	3104-796847	05/09/2023	SHOP - ALUM WHEEL WEIGHTS	01-15-00-51900	PUBLIC WORKS	\$12.27
	3104-796916	05/09/2023	SHOP - STEEL WHEEL WEIGHTS	01-15-00-51700	PUBLIC WORKS	\$9.34
	3104-796827	05/09/2023	WRENCH	01-15-00-51900	PUBLIC WORKS	\$73.10
	3104-797108	05/09/2023	#134 - RATCHET STRAP FOR WATER TANK	01-18-00-52000	STREET DEPARTMENT	\$21.99
	3104-797102	05/09/2023	#134 - STRAP FOR WATER TANK	01-18-00-52000	STREET DEPARTMENT	\$21.99
						<b>VENDOR TOTAL:</b>
						<b>\$786.49</b>
<b>GO DADDY</b>						
	2514836227	04/28/2023	2 YEAR PLAN	01-01-00-53600	CITY ADMINISTRATION	\$399.98
						<b>VENDOR TOTAL:</b>
						<b>\$399.98</b>
<b>GOVERNMENT FINANCE OFFICERS</b>						
	752438	04/30/2023	GFOA - CLOSING EVENT - L EHLUND	01-01-00-56200	CITY ADMINISTRATION	\$35.00
						<b>VENDOR TOTAL:</b>
						<b>\$35.00</b>
<b>GW &amp; ASSOCIATES PC</b>						
	2304188	04/30/2023	AUDIT FIELDWORK - APRIL 2023	01-01-00-53100	CITY ADMINISTRATION	\$20,325.00
						<b>VENDOR TOTAL:</b>
						<b>\$20,325.00</b>
<b>HALOGEN SUPPLY COMPANY</b>						
	594847	05/09/2023	(2) 2 GAL EPOXY FOR CENTRAL SQUARE FOUNTAIN	01-18-00-56810	STREET DEPARTMENT	\$649.79
						<b>VENDOR TOTAL:</b>
						<b>\$649.79</b>
<b>HARRINGTON INDUSTRIAL PLASTICS</b>						
	2313596	04/28/2023	** CREDIT ** FREIGHT - DID NOT SHIP 1 DAY HAS QL	20-16-00-52200	PUBLIC WORKS	\$(57.92)
	2313514	04/28/2023	FREIGHT	20-16-00-52200	PUBLIC WORKS	\$16.71
						<b>VENDOR TOTAL:</b>
						<b>\$(41.21)</b>
<b>HARRINGTON INDUSTRIAL PLASTICS LLC</b>						
	2313514	04/28/2023	ELEC ACT TUBV PVC	20-16-00-52200	PUBLIC WORKS	\$629.91
						<b>VENDOR TOTAL:</b>
						<b>\$629.91</b>

INVOICE REGISTER FOR CITY OF LOCKPORT  
 EXP CHECK RUN DATES 04/26/2023 - 05/09/2023  
 JOURNALIZED  
 PAID

VENDOR NAME	INVOICE NUMBER	INVOICE DATE	DESCRIPTION	ACCOUNT #	DEPARTMENT	ITEM AMOUNT
<b>HAWKINS, INC.</b>						
	6456707	04/29/2023	POLYMER	20-16-00-51830	PUBLIC WORKS	\$5,974.56
	6456705	04/29/2023	ALUMINUM SULFATE	20-16-00-51840	PUBLIC WORKS	\$3,915.60
	6454529	04/29/2023	POLYMER	20-16-00-51830	PUBLIC WORKS	\$4,995.06
	6454906	04/29/2023	TUBING & FILTERS FOR GAS FEED REGULATORS	20-16-00-52200	PUBLIC WORKS	\$218.50
	6448995	04/29/2023	CHLORINE , HYDROFLUOSILICIC ACID	20-15-00-51820	PUBLIC WORKS	\$7,310.80
	6447831	04/29/2023	CYLINDER CHARGES	20-15-00-51820	PUBLIC WORKS	\$450.00
					<b>VENDOR TOTAL:</b>	<b>\$22,864.52</b>
<b>HEIDELBERG MATERIALS MIDWEST AGG</b>						
	42157003	04/30/2023	20 LOADS OF CA-6 TO CHEVRON	01-01-00-52705	CITY ADMINISTRATION	\$5,961.11
	42182249	04/30/2023	RIP RAP STONES 3" SIZE **TOTAL IS AN EST**	01-18-00-52310	STREET DEPARTMENT	\$129.93
					<b>VENDOR TOTAL:</b>	<b>\$6,091.04</b>
<b>HOLIDAY INN PEORIA</b>						
	WY7U7WY	04/30/2023	ILCMA - HOTEL - B BENSON	01-01-00-56200	CITY ADMINISTRATION	\$607.19
					<b>VENDOR TOTAL:</b>	<b>\$607.19</b>
<b>HOME DEPOT</b>						
	* CREDIT *	04/28/2023	* CREDIT * ORGINAL RECEIPT 1989 001 11989 -SWIT	01-04-00-52100	POLICE DEPARTMENT	\$(83.03)
	476521/40523330	04/28/2023	SCHLAGE PASSAGE	01-04-00-52100	POLICE DEPARTMENT	\$31.47
	928099/4062497	04/28/2023	25 FT PUSH FIT FOR ICEMAKER	01-04-00-52100	POLICE DEPARTMENT	\$11.42
	141851/2084498	04/28/2023	KITCHEN SINK STRAINER, SNOZZLE APPLICATTOR,	01-04-00-52100	POLICE DEPARTMENT	\$135.73
	319793/9015312	04/28/2023	OUTLETS AND PLATES FOR STATION	01-04-00-52100	POLICE DEPARTMENT	\$86.41
					<b>VENDOR TOTAL:</b>	<b>\$182.00</b>
<b>HOME DEPOT CREDIT SERVICES</b>						
	6207549	04/28/2023	ITEMS FOR STREET DEPT. -SPRING WOUND IN WAL	01-18-00-51900	STREET DEPARTMENT	\$82.03
	7052766	04/28/2023	CORNER BRACE, CANE BOLT, WEX BOLT	01-18-00-56810	STREET DEPARTMENT	\$34.76
	6020834	04/28/2023	LOCK FOR CITY HALL-KEYPAD LEVER, ALUMINUM P	01-01-00-52700	CITY ADMINISTRATION	\$252.98
	5020975	04/28/2023	HEX BOLT	01-18-00-56810	STREET DEPARTMENT	\$10.60
					<b>VENDOR TOTAL:</b>	<b>\$380.37</b>
<b>HOMER INDUSTRIES, LLC</b>						
	S194132	04/29/2023	DROP CHARGE -CHIPS	01-06-00-52210	YARD WASTE	\$25.00
	S193445	04/29/2023	DROP CHARGE - CHIPS	01-06-00-52210	YARD WASTE	\$25.00
	S193883	04/29/2023	DROP CHARGE - CHIPS	01-06-00-52210	YARD WASTE	\$25.00
	S194604	05/09/2023	DROP CHARGE - CHIPS	01-06-00-52210	YARD WASTE	\$25.00
	S194236	05/09/2023	DROP CHARGE - CHIPS	01-06-00-52210	YARD WASTE	\$25.00
	S194688	05/09/2023	DROP CHARGE - CHIPS	01-06-00-52210	YARD WASTE	\$25.00
					<b>VENDOR TOTAL:</b>	<b>\$150.00</b>
<b>HOMER TREE CARE INC.</b>						
	51831	04/29/2023	TREE REMOVAL & PRUNING @ 820 WASHINGTON	01-18-00-52420	STREET DEPARTMENT	\$2,200.00
					<b>VENDOR TOTAL:</b>	<b>\$2,200.71</b>

INVOICE REGISTER FOR CITY OF LOCKPORT  
 EXP CHECK RUN DATES 04/26/2023 - 05/09/2023  
 JOURNALIZED  
 PAID

VENDOR NAME	INVOICE NUMBER	INVOICE DATE	DESCRIPTION	ACCOUNT #	DEPARTMENT	ITEM AMOUNT
-----						
HOMETOWN PROS, INC.	MAY 2023	05/01/2023	PRO CHAMPS MONTHLY STIPEND - MAY 2023	01-08-00-53200	BUILDING DEPARTMENT	\$500.00
					<b>VENDOR TOTAL:</b>	<b>\$500.00</b>
HOSTGATOR.COM	3/30/2023	04/30/2023	HOSTGATOR.COM	01-01-00-53600	CITY ADMINISTRATION	\$419.40
					<b>VENDOR TOTAL:</b>	<b>\$419.40</b>
IGFOA	IGFOA REGISTRATIC	04/28/2023	INTERNAL CONTROL SEMINAR 05/02/2023	01-01-00-56200	CITY ADMINISTRATION	\$125.00
					<b>VENDOR TOTAL:</b>	<b>\$125.00</b>
IL WI SERTOMA REGIONAL CENTER	49075	04/30/2023	OCCUPATIONAL HEARING EXAMS - OSHA HEARING	01-18-00-52820	STREET DEPARTMENT	\$49.00
	48645	04/30/2023	OCCUPATIONAL HEARING EXAMS - OSHA HEARING	01-18-00-52820	STREET DEPARTMENT	\$898.00
					<b>VENDOR TOTAL:</b>	<b>\$947.00</b>
ILLINOIS ASSOCIATION FOR FLOODPLAIN	17162	05/09/2023	MEMBERSHIP DUES -B CANN	01-09-00-51400	ENGINEERING	\$25.00
					<b>VENDOR TOTAL:</b>	<b>\$25.00</b>
ILLINOIS PUBLIC RISK FUND	81568	05/03/2023	WORKERS COMP INSURANCE - JUNE	01-01-00-54000	CITY ADMINISTRATION	\$26,246.00
					<b>VENDOR TOTAL:</b>	<b>\$26,246.00</b>
ILLINOIS STATE TOLL HIGHWAY	VN5905142483	04/30/2023	TOLLWAY REPLENISH - #703	01-01-00-51500	CITY ADMINISTRATION	\$20.40
	239927	04/30/2023	I PASS REPLENISH	01-01-00-51500	CITY ADMINISTRATION	\$40.00
					<b>VENDOR TOTAL:</b>	<b>\$60.40</b>
INTEGRITY FIRE EQUIPMENT, INC.	69379	04/30/2023	MONTHLY FIRE EXTINGUISHER CHECK@P.D.	01-04-00-52200	POLICE DEPARTMENT	\$40.00
					<b>VENDOR TOTAL:</b>	<b>\$40.00</b>
INTERSTATE BATTERIES OF	50917689	04/30/2023	BATTERIES FOR PD AND STREET	01-04-00-52000	POLICE DEPARTMENT	\$419.85
					<b>VENDOR TOTAL:</b>	<b>\$419.85</b>
JENNIFER KEARNEY	FEB/MARCH	04/28/2023	PREPARATION/PROSECUTION OF LOCKPORT OV/TF	01-01-00-53200	CITY ADMINISTRATION	\$3,052.50
	APRIL	04/28/2023	PREPARATION/PROSECUTION OF LOCKPORT OV/TF	01-01-00-53200	CITY ADMINISTRATION	\$1,470.00
					<b>VENDOR TOTAL:</b>	<b>\$4,522.50</b>
JIM'S TRUCK INSPECTION LLC	197212	05/09/2023	#121 - SAFETY LANE INSPECTION	01-18-00-52000	STREET DEPARTMENT	\$37.00
	197213	05/09/2023	#116 - SAFETY LANE INSPECTION	01-18-00-52000	STREET DEPARTMENT	\$37.00
	197196	05/09/2023	#120 - SAFETY LANE INSPECTION	01-18-00-52000	STREET DEPARTMENT	\$37.00

INVOICE REGISTER FOR CITY OF LOCKPORT  
 EXP CHECK RUN DATES 04/26/2023 - 05/09/2023  
 JOURNALIZED  
 PAID

VENDOR NAME	INVOICE NUMBER	INVOICE DATE	DESCRIPTION	ACCOUNT #	DEPARTMENT	ITEM AMOUNT	
						<b>VENDOR TOTAL:</b>	<b>\$111.00</b>
JOHN/SHARON/KRISTINE ODOM	05/01/2023	04/29/2023	UB refund for account: 0020004500-02	20-00-00-12500	CTY ADMIN OR CPTL OUTLY	\$40.68	
						<b>VENDOR TOTAL:</b>	<b>\$40.68</b>
KD LANDSCAPE, INC.	17121	04/30/2023	LANDSCAPE SERVICES FOR CENTRAL SQUARE APF	01-01-00-52700	CITY ADMINISTRATION	\$1,303.00	
						<b>VENDOR TOTAL:</b>	<b>\$1,303.00</b>
KONICA MINOLTA PREMIER FINANCE	499223089	05/03/2023	DESIGNJET COPIER RENTAL@ENG DEPT	01-09-00-52200	ENGINEERING	\$268.27	
	500204458	05/03/2023	KONJICA MINOLTA BIZHUB COPIER@P.D.	01-04-00-52200	POLICE DEPARTMENT	\$196.00	
						<b>VENDOR TOTAL:</b>	<b>\$464.27</b>
LANDS END BUSINESS OUTFITTERS	SIN11114123	04/28/2023	UNIFORM SHIRTS	01-04-00-51600	POLICE DEPARTMENT	\$744.02	
	SO-20230329-14003E04/28/2023		SHIRTS	01-04-00-51600	POLICE DEPARTMENT	\$207.00	
						<b>VENDOR TOTAL:</b>	<b>\$951.02</b>
LAUTERBACH & AMEN, LLP	APRIL 2023	04/28/2023	PD MONTHLY PENSION ALLOCATION APRIL 2023	01-04-00-56850	POLICE DEPARTMENT	\$150,000.00	
	77496	04/30/2023	ACTUARIAL REPORT - TAX LEVY - POLICE	01-01-00-53200	CITY ADMINISTRATION	\$1,475.00	
						<b>VENDOR TOTAL:</b>	<b>\$151,475.00</b>
LOCK & MULE	152503	04/30/2023	CITY OF LOCKPORT/VILLAGE OF LEMONT MAYORAI	01-01-00-56800	CITY ADMINISTRATION	\$90.60	
						<b>VENDOR TOTAL:</b>	<b>\$90.60</b>
LOCKPORT CHAMBER OF COMMERCE	STATE OF CITY	04/30/2023	STATE OF THE CITY ADDRESS - C BERGBOWER	01-01-00-56310	CITY ADMINISTRATION	\$40.00	
						<b>VENDOR TOTAL:</b>	<b>\$40.00</b>
LOCKPORT HEIGHTS SANITARY	MAY 2023	05/01/2023	MONTHLY CONTRIBUTION -MAY 2023	20-15-00-56930	PUBLIC WORKS	\$15,600.81	
						<b>VENDOR TOTAL:</b>	<b>\$15,600.81</b>
LOCKPORT TOWNSHIP PARK DIST.	2023-06	05/09/2023	PARK DISTRICT CHECK VALVE REPAIR *INTERNAL	20-24-00-67100	WATER/SEWER CAPITAL	\$2,052.00	
						<b>VENDOR TOTAL:</b>	<b>\$2,052.00</b>
M/I Homes of Chicago	15419 Summerwind	05/09/2023	BD Bond Refund	01-00-00-21600	CTY ADMIN OR CPTL OUTLY	\$300.00	
						<b>VENDOR TOTAL:</b>	<b>\$300.00</b>
MAILCHIMP	MC13048776	04/30/2023	RENTAL PROGRAM - APRIL	01-01-00-56301	CITY ADMINISTRATION	\$13.00	
						<b>VENDOR TOTAL:</b>	<b>\$13.73</b>

INVOICE REGISTER FOR CITY OF LOCKPORT  
 EXP CHECK RUN DATES 04/26/2023 - 05/09/2023  
 JOURNALIZED  
 PAID

VENDOR NAME	INVOICE NUMBER	INVOICE DATE	DESCRIPTION	ACCOUNT #	DEPARTMENT	ITEM AMOUNT
MARLEY	105779-001008	04/30/2023	ILLUMINATE VIP NIGHT	01-01-00-56310	CITY ADMINISTRATION	\$200.00
					<b>VENDOR TOTAL:</b>	<b>\$200.00</b>
MCMASTER-CARR SUPPLY CMLAY	96782727	04/30/2023	BOX FOR TOTAL FLOW METER	20-24-00-67250	WATER/SEWER CAPITAL	\$1,129.55
					<b>VENDOR TOTAL:</b>	<b>\$1,129.55</b>
MEADE INC.	704448	04/29/2023	REPAIR 9TH ST BRIDGE STREETLIGHTS	01-18-00-52210	STREET DEPARTMENT	\$5,479.58
	703971	04/29/2023	INSTALL NEW CLOCK AT METRA STATION	01-03-00-52020	COMMUTER LOT	\$493.73
	704173	04/29/2023	TRAFFIC SIGNAL MAINT - APRIL 2023	01-18-00-52211	STREET DEPARTMENT	\$1,245.58
	704519	04/30/2023	FURNISH TRAFFIC SIGNAL WALK TIME SIGN - APRIL	01-18-00-52211	STREET DEPARTMENT	\$1,213.00
					<b>VENDOR TOTAL:</b>	<b>\$8,431.89</b>
MEDWORKS JOLIET CORP.	279960-001	04/30/2023	HEALTH EXAM - A DEHOYES	01-04-00-56810	POLICE DEPARTMENT	\$940.32
	279811-001	04/30/2023	HEALTH EXAM - Z LEHMACHER	01-04-00-56810	POLICE DEPARTMENT	\$940.32
					<b>VENDOR TOTAL:</b>	<b>\$1,880.64</b>
MIDWEST TIME RECORDER, INC.	190220	04/30/2023	TIME & ATTENDANCE MAINTENACE - APRIL	01-01-00-53600	CITY ADMINISTRATION	\$134.00
					<b>VENDOR TOTAL:</b>	<b>\$134.00</b>
NAAG TAG INC.	NG-335945	04/30/2023	NAME TAG FOR JONATHAN PUGH	01-01-00-51000	CITY ADMINISTRATION	\$17.73
					<b>VENDOR TOTAL:</b>	<b>\$17.73</b>
NEW ERA SPREADING INC	468	04/29/2023	SLUDGE HAUL - 4/17/23	20-16-00-52810	PUBLIC WORKS	\$2,280.00
	472	04/30/2023	SLUDGE HAULFROM BBFM-APRIL	20-16-00-52810	PUBLIC WORKS	\$33,930.00
					<b>VENDOR TOTAL:</b>	<b>\$36,210.00</b>
NICOR	88 77 96 0753 5	04/29/2023	610 E 3RD STREET - 3/30 - 4/13	01-01-00-56800	CITY ADMINISTRATION	\$82.67
	10 37 54 0942 1-14	04/30/2023	141ST STREET LIFT STATION - APRIL	20-16-00-53800	PUBLIC WORKS	\$55.96
					<b>VENDOR TOTAL:</b>	<b>\$138.63</b>
NORTHERN ILLINOIS UNIVERSITY	692621	04/30/2023	REGISTRATION - CIVIC LEADERSHIP ACADEMY - B C	01-01-00-56200	CITY ADMINISTRATION	\$162.00
	692691	04/30/2023	REGISTRATION-12TH ANNUAL WOMEN'S LEGACY C	01-01-00-56200	CITY ADMINISTRATION	\$120.00
	692985	05/03/2023	ILCMA SUMMER CONFERENCE - REGISTRATION - B	01-01-00-56200	CITY ADMINISTRATION	\$250.00
					<b>VENDOR TOTAL:</b>	<b>\$532.00</b>
NORWALK TANK COMPANY	186767	04/30/2023	CULVERT PIPE	01-18-00-52310	STREET DEPARTMENT	\$715.05

INVOICE REGISTER FOR CITY OF LOCKPORT  
 EXP CHECK RUN DATES 04/26/2023 - 05/09/2023  
 JOURNALIZED  
 PAID

VENDOR NAME	INVOICE NUMBER	INVOICE DATE	DESCRIPTION	ACCOUNT #	DEPARTMENT	ITEM AMOUNT	
						<b>VENDOR TOTAL:</b>	<b>\$715.05</b>
ORKIN PEST CONTROL	247048477	04/28/2023	PEST CONTROL @ CITY HALL - APRIL	01-01-00-52700	CITY ADMINISTRATION	\$1,000.00	
						<b>VENDOR TOTAL:</b>	<b>\$1,000.00</b>
PAPA JOE'S OF LOCKPORT	382364	04/28/2023	PIZZAS FOR HIGH SCHOOL TOUR	01-16-00-68000	PUBLIC WORKS	\$225.18	
						<b>VENDOR TOTAL:</b>	<b>\$225.18</b>
POLICE LAW INSTITUTE,INC	23009	04/28/2023	TRAINING FOR HAZMAT AND BLOOD PATH	01-04-00-56200	POLICE DEPARTMENT	\$600.00	
						<b>VENDOR TOTAL:</b>	<b>\$600.00</b>
PRECISE MRM LLC	200-1042536	04/30/2023	GPS LICENSE & MAINTENANCE - MARCH 2023	01-18-00-52800	STREET DEPARTMENT	\$280.00	
						<b>VENDOR TOTAL:</b>	<b>\$280.00</b>
QUILL CORPORATION	32115552	04/29/2023	DUSTER	01-04-00-51000	POLICE DEPARTMENT	\$48.00	
	31936657	04/29/2023	8.5 X 11 PAPER	01-04-00-51000	POLICE DEPARTMENT	\$174.96	
	32166011	04/29/2023	STORAGE BAGS, COFFEE, TAPE, HALF & HALF	01-01-00-51000	CITY ADMINISTRATION	\$106.73	
						<b>VENDOR TOTAL:</b>	<b>\$329.69</b>
RAY O'HERRON	2266555	04/28/2023	STARS - R HUFF	01-04-00-51600	POLICE DEPARTMENT	\$15.39	
	2266730	04/28/2023	UNIFORM ALLOWANCE - Z LEHMACHER	01-04-00-51600	POLICE DEPARTMENT	\$224.97	
	2266662	04/28/2023	UNIFORM ALLOWANCE - A DEHOYOS	01-04-00-51600	POLICE DEPARTMENT	\$659.79	
	2267952	05/09/2023	UNIFORM ALLOWANCE - FOX	01-04-00-51600	POLICE DEPARTMENT	\$224.97	
	2267308	04/30/2023	UNIFORM ALLOWANCE - FOX	01-04-00-51600	POLICE DEPARTMENT	\$160.97	
						<b>VENDOR TOTAL:</b>	<b>\$1,286.09</b>
READYREFRESH BY NESTLE'	03D0124774613	04/28/2023	WATER DISPENSERS@CITY HALL & BBFM	01-01-00-56801	CITY ADMINISTRATION	\$196.94	
	03D6701651081	04/30/2023	WATER DISPENSER@P.D. GYM - APRIL	01-01-00-56801	CITY ADMINISTRATION	\$28.99	
						<b>VENDOR TOTAL:</b>	<b>\$225.93</b>
ROGUE	138738	04/28/2023	MODEL D ROWER, ECHO BIKE	01-01-00-56801	CITY ADMINISTRATION	\$1,939.45	
						<b>VENDOR TOTAL:</b>	<b>\$1,939.45</b>
RUETTIGER,TONELLI & ASSOCIATES	307	04/28/2023	PROFESSIONAL SERVICES 5TH & MADISON	01-01-00-53200	CITY ADMINISTRATION	\$1,206.25	
						<b>VENDOR TOTAL:</b>	<b>\$1,206.25</b>
RUSH TRUCK CENTER	3032364466	05/09/2023	#124 - MUFFLER STRAP	01-18-00-52000	STREET DEPARTMENT	\$61.90	

INVOICE REGISTER FOR CITY OF LOCKPORT  
 EXP CHECK RUN DATES 04/26/2023 - 05/09/2023  
 JOURNALIZED  
 PAID

VENDOR NAME	INVOICE NUMBER	INVOICE DATE	DESCRIPTION	ACCOUNT #	DEPARTMENT	ITEM AMOUNT	
						<b>VENDOR TOTAL:</b>	<b>\$61.90</b>
SAFE BUILT ILLINOIS, LLC	98518-IN	04/30/2023	REVEIW FOR HOMER PERMIT AND W/BRIAN P - APR 01-08-00-53210		BUILDING DEPARTMENT	\$308.25	
						<b>VENDOR TOTAL:</b>	<b>\$308.25</b>
SAFEGUARD BUSINESS SYSTEMS	9001189830	05/09/2023	A/P GREEN DISBURSEMENT CHECKS - STARTING # 01-01-00-51000		CITY ADMINISTRATION	\$452.37	
						<b>VENDOR TOTAL:</b>	<b>\$452.37</b>
SAM'S CLUB/GEMB	85560532M01MHED	04/28/2023	ILLUMINATE EVENT - PLASTIC PLATES, CUTLERY	01-01-00-56310	CITY ADMINISTRATION	\$39.46	
	FI469002P000LF087	04/28/2023	REFUND OF LATE FEES	01-01-00-56800	CITY ADMINISTRATION	\$(15.99)	
	* REFUND *	04/28/2023	REFUND OF DISPUTED CHARGES LAST STATEMENT	01-01-00-56800	CITY ADMINISTRATION	\$(9.22)	
						<b>VENDOR TOTAL:</b>	<b>\$14.25</b>
SAQ CONSULTING, INC.	MAY 2023	05/01/2023	CONSULTING SERVICES-MAY 2023	01-01-00-53200	CITY ADMINISTRATION	\$4,000.00	
						<b>VENDOR TOTAL:</b>	<b>\$4,000.00</b>
SECRETARY OF STATE	60217092	04/28/2023	PLATE RENEWAL SQUAD 511	01-04-00-56800	POLICE DEPARTMENT	\$154.40	
	60469495	04/28/2023	#501 - PLATE RENEWAL	01-04-00-56800	POLICE DEPARTMENT	\$154.40	
						<b>VENDOR TOTAL:</b>	<b>\$308.80</b>
SECRETARY OF STATE (VEH SRV DEPT)	TRAILER - TITLE	05/08/2023	TRAILER TITLE	20-15-00-52000	PUBLIC WORKS	\$163.00	
						<b>VENDOR TOTAL:</b>	<b>\$163.00</b>
SERVICE INDUSTRIAL SUPPLY INC	134664	05/09/2023	HOSE REPAIR	01-15-00-52200	PUBLIC WORKS	\$40.00	
						<b>VENDOR TOTAL:</b>	<b>\$40.00</b>
SHAW SUBURBAN MEDIA GROUP, INC.	4/10/2023	04/28/2023	HERALD NEWS SUBSCRIPTION	01-09-00-51400	ENGINEERING	\$17.33	
	2065784	04/30/2023	ADVERTISE RFQ IL 7 CHANNELIZATION	01-09-00-56300	ENGINEERING	\$311.30	
						<b>VENDOR TOTAL:</b>	<b>\$328.63</b>
SHI INTERNATIONAL CORP	B16802982	04/28/2023	BLUEBEAM SOFTWARE RENEWAL	01-01-00-53600	CITY ADMINISTRATION	\$158.34	
						<b>VENDOR TOTAL:</b>	<b>\$158.34</b>
SONNI C. WILLIAMS	672276	05/03/2023	IL. STATE BAR ASSOC. ANNUAL DUES REIMBURSEMENT	01-01-00-51400	CITY ADMINISTRATION	\$415.00	
						<b>VENDOR TOTAL:</b>	<b>\$415.00</b>
SOUTHWEST AIRLINES	2GFQDH	04/30/2023	ICMA ANNUAL CONFERENCE- AIR FARE - BENSON	01-01-00-56200	CITY ADMINISTRATION	\$20.00	

INVOICE REGISTER FOR CITY OF LOCKPORT  
 EXP CHECK RUN DATES 04/26/2023 - 05/09/2023  
 JOURNALIZED  
 PAID

VENDOR NAME	INVOICE NUMBER	INVOICE DATE	DESCRIPTION	ACCOUNT #	DEPARTMENT	ITEM AMOUNT
	2GFQDH -B	04/30/2023	ILCMA ANNUAL CONFERENCE - AIR FARE - B BENS	01-01-00-56200	CITY ADMINISTRATION	\$20.00
	2GFQDH-C	04/30/2023	ILCA - ANNUAL CONFERENCE - AIR FARE - B BENS	01-01-00-56200	CITY ADMINISTRATION	\$355.96
					<b>VENDOR TOTAL:</b>	<b>\$395.96</b>
STEVE BURESH'S CHEESECAKE STORE						
	04/04/2023	04/28/2023	TELECOMMUNICATORS WEEK	01-04-00-56800	POLICE DEPARTMENT	\$362.47
					<b>VENDOR TOTAL:</b>	<b>\$362.47</b>
STICKER MULE, LLC						
	R142864513	04/28/2023	MAGNETS FOR CARS	01-04-00-56800	POLICE DEPARTMENT	\$209.00
					<b>VENDOR TOTAL:</b>	<b>\$209.00</b>
SUBURBAN LABORATORIES						
	213688	04/28/2023	VARIOUS WATER SAMPLE TESTING CONTRACT-FLL	20-15-00-51811	PUBLIC WORKS	\$23.10
	213565	04/30/2023	VARIOUS WATER SAMPLE TESTING CONTRACT FOF	20-15-00-51811	PUBLIC WORKS	\$4,891.37
					<b>VENDOR TOTAL:</b>	<b>\$4,914.47</b>
SURVEY MONKEY						
	ADVANTAGE ANNUA	04/30/2023	ADVANTAGE ANNUAL SUBSCRIPTION	01-01-00-51400	CITY ADMINISTRATION	\$468.00
					<b>VENDOR TOTAL:</b>	<b>\$468.00</b>
SWAHM						
	MAY 2023	05/03/2023	INSURANCE-CITY ADMIN,P.D.,PLNG,BLDG,ENG,STRI	01-01-00-54100	CITY ADMINISTRATION	\$189,487.80
					<b>VENDOR TOTAL:</b>	<b>\$189,487.80</b>
TAI GINSBERG & ASSOCIATES, LLC						
	MAY 2023	05/01/2023	FEDERAL GRANTS & INFRASTRUCTURE STRATEGIC	01-01-00-53200	CITY ADMINISTRATION	\$5,250.00
					<b>VENDOR TOTAL:</b>	<b>\$5,250.00</b>
TD CUSTOM FRAMING SOLUTIONS						
	548 E 10th St	04/28/2023	BD Bond Refund	01-00-00-21600	CTY ADMIN OR CPTL OUTLY	\$600.00
	548 E 10th Street	04/28/2023	BD Bond Refund	01-00-00-21600	CTY ADMIN OR CPTL OUTLY	\$500.00
					<b>VENDOR TOTAL:</b>	<b>\$1,100.00</b>
TEKLAB, INC.						
	286880	04/28/2023	MONTHLY NPDES TESTING FOR LOCKPORT STP & F	20-16-00-52800	PUBLIC WORKS	\$624.95
					<b>VENDOR TOTAL:</b>	<b>\$624.95</b>
THE CUPCAKERY BAKERY CO.						
	254	04/30/2023	ILLUMINATE EVENT	01-01-00-56310	CITY ADMINISTRATION	\$15.12
					<b>VENDOR TOTAL:</b>	<b>\$15.12</b>
THE LOCKPORT STAGECOACH LLC						
	3/23/2023	04/30/2023	IL AMERICAN -BEN, BRENT	01-01-00-56800	CITY ADMINISTRATION	\$85.48
					<b>VENDOR TOTAL:</b>	<b>\$85.48</b>
THE SHERWIN-WILLIAMS CO.						
	4634-2	04/28/2023	PAINT FOR SW CLARIFIER	20-16-00-52200	PUBLIC WORKS	\$3,762.77

INVOICE REGISTER FOR CITY OF LOCKPORT  
 EXP CHECK RUN DATES 04/26/2023 - 05/09/2023  
 JOURNALIZED  
 PAID

VENDOR NAME	INVOICE NUMBER	INVOICE DATE	DESCRIPTION	ACCOUNT #	DEPARTMENT	ITEM AMOUNT	
						<b>VENDOR TOTAL:</b>	<b>\$3,762.50</b>
THOMSON REUTERS - WEST	848239055	04/30/2023	ONLINE SOFTWARE (P.O. 21-09167)/CITY ATTORNEY	01-01-00-51400	CITY ADMINISTRATION	\$250.20	
						<b>VENDOR TOTAL:</b>	<b>\$250.20</b>
TIFCO INDUSTRIES	71862774	04/30/2023	PLUG KIT FOR HYDRAULIC HOSES	01-15-00-52200	PUBLIC WORKS	\$89.95	
						<b>VENDOR TOTAL:</b>	<b>\$89.95</b>
TKB ASSOCIATES, INC.	14968	05/09/2023	ANNUAL LASERFICHE PRODUCT	01-01-00-53600	CITY ADMINISTRATION	\$1,686.00	
						<b>VENDOR TOTAL:</b>	<b>\$1,686.00</b>
TRAILBLAZER PLUMBING	33203011	04/28/2023	CLEARED DRAINS IN PRELIM BUILDING	20-16-00-52100	PUBLIC WORKS	\$945.00	
						<b>VENDOR TOTAL:</b>	<b>\$945.00</b>
TRANSUNION RISK AND ALTERNATIVE	922161-202304-1	04/30/2023	TLO MONTHLY CHARGE - APRIL	01-04-00-52200	POLICE DEPARTMENT	\$190.00	
						<b>VENDOR TOTAL:</b>	<b>\$190.00</b>
TRAVELERS	627299	04/30/2023	CLAIM #FWT5135 - DATE OF LOSS 9/15/2022	01-01-00-54000	CITY ADMINISTRATION	\$526.50	
						<b>VENDOR TOTAL:</b>	<b>\$526.50</b>
TREASURER, STATE OF ILLINOIS	125536	04/28/2023	2022 STREETScape COST SHARE	14-00-00-53200	CTY ADMIN OR CPTL OUTLY	\$139,833.92	
						<b>VENDOR TOTAL:</b>	<b>\$139,833.92</b>
TWIG TECHNOLOGIES	373	04/30/2023	GIS IT & MAINTENANCE - MARCH	20-24-00-67000	WATER/SEWER CAPITAL	\$6,891.25	
						<b>VENDOR TOTAL:</b>	<b>\$6,891.25</b>
UNITED DOOR & LOCK LLC	5410	04/30/2023	REPAIR OF DOOR FOR SALLY PORT	01-04-00-52100	POLICE DEPARTMENT	\$6,800.00	
						<b>VENDOR TOTAL:</b>	<b>\$6,800.00</b>
USA BLUE BOOK	330319	04/28/2023	LAB SUPPLIES - MFC BROTH	20-16-00-51810	PUBLIC WORKS	\$297.15	
	327461	04/30/2023	LAB SUPPLIES-BUFFERS, PADS & FILTERS	20-16-00-51810	PUBLIC WORKS	\$677.21	
	346234	04/30/2023	2 - GAUGES	20-15-00-52260	PUBLIC WORKS	\$169.90	
	344796	04/30/2023	LAB SUPPLIES - PADS & FILTERS	20-16-00-51810	PUBLIC WORKS	\$140.25	
	347316	04/30/2023	LEAD WASHERS FOR CYLINDERS	20-16-00-51900	PUBLIC WORKS	\$103.35	
	349802	04/30/2023	CL2 SCALE FOR BOOSTER STATION	20-15-00-52220	PUBLIC WORKS	\$2,432.76	
						<b>VENDOR TOTAL:</b>	<b>\$3,820.62</b>
V.I.P.SERVICES, INC.							

INVOICE REGISTER FOR CITY OF LOCKPORT  
 EXP CHECK RUN DATES 04/26/2023 - 05/09/2023  
 JOURNALIZED  
 PAID

VENDOR NAME	INVOICE NUMBER	INVOICE DATE	DESCRIPTION	ACCOUNT #	DEPARTMENT	ITEM AMOUNT
	31509	04/28/2023	VALET SERVICES - 4/21/2023, 4/22/2023, ADDITIONA	01-01-00-52805	CITY ADMINISTRATION	\$1,610.00
	31563	04/30/2023	VALET SERVICES -4/28/2023,4/29/2023	01-01-00-52805	CITY ADMINISTRATION	\$1,610.00
					<b>VENDOR TOTAL:</b>	<b>\$3,220.00</b>
V3 COMPANIES						
	323603	04/30/2023	GRANT APP 8TH STREET PED BRIDGE-MARCH	14-00-00-53200	CTY ADMIN OR CPTL OUTLY	\$3,405.00
	323602	04/30/2023	ENVIRONMENTAL CONSULTATION -MARCH	01-01-00-52705	CITY ADMINISTRATION	\$956.25
					<b>VENDOR TOTAL:</b>	<b>\$4,361.25</b>
VEGA BUILDING MAINT & SUPPLIES, INC						
	45741	04/28/2023	BLINDS CLEANING@CITY HALL	01-01-00-52700	CITY ADMINISTRATION	\$715.00
	101187	04/29/2023	CLEANING CONTRACT FOR PW, STP, CITY HALL-AF	01-16-00-52800	PUBLIC WORKS	\$3,021.00
	101196	04/30/2023	CLEANING@P.D. - APRIL	01-04-00-52200	POLICE DEPARTMENT	\$1,800.00
					<b>VENDOR TOTAL:</b>	<b>\$5,536.00</b>
VISTAPRINT NETHERLANDS BV						
	VP_67S43F39	04/30/2023	VINYL BANNERS - FRIDAY IN THE PARK	01-01-00-56310	CITY ADMINISTRATION	\$205.61
					<b>VENDOR TOTAL:</b>	<b>\$205.61</b>
WALMART						
	2000107-6789151	04/28/2023	COFFEE	01-16-00-51000	PUBLIC WORKS	\$113.82
	REFRESHMENTS	04/28/2023	LEAD REPLACEMENT PROJECT MEETING RERFRES	01-09-00-56800	ENGINEERING	\$24.57
					<b>VENDOR TOTAL:</b>	<b>\$138.39</b>
WASTE MANAGEMENT						
	0001000-2007-2	04/30/2023	SLOYAN PAD SERVICES - APRIL 2023	01-01-00-56800	CITY ADMINISTRATION	\$444.00
	6471758-2007-3	04/30/2023	RESIDENTIAL GARBAGE - APRIL	20-06-00-52750	YARD WASTE	\$263,218.30
					<b>VENDOR TOTAL:</b>	<b>\$263,662.30</b>
WESCOM						
	20230411	04/28/2023	DISPATCH SERVICE, AIRTIME FEES - APRIL 2023	01-04-00-52830	POLICE DEPARTMENT	\$35,610.98
	20230611	05/09/2023	MONTHLY DISPATCH FEE, AIRTIME FEES - JUNE	01-04-00-52830	POLICE DEPARTMENT	\$35,371.03
					<b>VENDOR TOTAL:</b>	<b>\$70,982.01</b>
WEST SIDE SPECIALIZED SERVICE						
	I04340	05/08/2023	PURCHASE OF A NEW 2022 FELLING FT-30-2 TILT TF	20-24-00-67200	WATER/SEWER CAPITAL	\$33,613.68
	I04332	04/28/2023	LIGHT TOWER/GENERATOR **2023**	20-15-00-51900	PUBLIC WORKS	\$12,700.00
					<b>VENDOR TOTAL:</b>	<b>\$46,313.68</b>
WEX BANK						
	89098675	04/30/2023	GASOLINE-OUT OF TOWN TO PICK UP SQUAD	01-04-00-51500	POLICE DEPARTMENT	\$95.71
					<b>VENDOR TOTAL:</b>	<b>\$95.71</b>
WHITMORE INVESTMENTS						
	579848	04/28/2023	ITEMS FOR DOWNTOWN FOUNTAIN -WATERWELD E	01-18-00-56810	STREET DEPARTMENT	\$24.58
	579845	04/28/2023	ITEMS FOR DOWNTOWN FOUNTAIN -ACETONE, PUT	01-18-00-56810	STREET DEPARTMENT	\$46.13
	579843	04/28/2023	PLUMBERS PUTTY	01-04-00-52100	POLICE DEPARTMENT	\$3.79

INVOICE REGISTER FOR CITY OF LOCKPORT  
 EXP CHECK RUN DATES 04/26/2023 - 05/09/2023  
 JOURNALIZED  
 PAID

VENDOR NAME	INVOICE NUMBER	INVOICE DATE	DESCRIPTION	ACCOUNT #	DEPARTMENT	ITEM AMOUNT
	579871	05/09/2023	HOSE DISCHARGE / TUBE BRAID	01-15-00-51700	PUBLIC WORKS	\$23.15
					<b>VENDOR TOTAL:</b>	<b>\$97.85</b>
WILL COUNTY BAR ASSOCIATION	2023-9	05/09/2023	WCBA MEMBERSHIP - S WILLIAMS	01-01-00-51400	CITY ADMINISTRATION	\$50.00
					<b>VENDOR TOTAL:</b>	<b>\$50.00</b>
WILL COUNTY GOVERNMENTAL LEAGU	WCGL REGISTRATIC	04/30/2023	WCGL REGISTRATION - MAYOR, BENSON	01-01-00-51400	CITY ADMINISTRATION	\$200.00
					<b>VENDOR TOTAL:</b>	<b>\$200.00</b>
WILLIAMS BROTHERS CONSTRUCTION	APP #10	04/30/2023	DIVISION STREET WWTP IMPROVEMENTS PHASE III	20-24-00-67100	WATER/SEWER CAPITAL	\$255,431.79
					<b>VENDOR TOTAL:</b>	<b>\$255,431.79</b>
WYNDHAM SPRINGFIELD CITY CENTRE	WCGL PARKING	04/30/2023	PARKING - WCGL - MAYOR	01-01-00-56200	CITY ADMINISTRATION	\$10.00
					<b>VENDOR TOTAL:</b>	<b>\$10.00</b>
XYLEM WATER SOLUTIONS USA, INC	3556C70118	04/28/2023	FLYGT SUBMERSIBLE PUMPS FOR BRIGGS ST. LIFT	20-24-00-67100	WATER/SEWER CAPITAL	\$111,864.61
					<b>VENDOR TOTAL:</b>	<b>\$111,864.61</b>
ZOOM VIDEO COMMUNICATIONS INC.	192850353	04/28/2023	MONTHLY SUBSCRIPTION	01-09-00-51400	ENGINEERING	\$15.99
					<b>VENDOR TOTAL:</b>	<b>\$15.99</b>
ZZOUNDS MUSIC, LLC	ZZ8810299	04/30/2023	WIRELESS HANDHELD MICROPHONE	01-01-00-56310	CITY ADMINISTRATION	\$212.45
	ZZ8810299-B	04/30/2023	LIGHTWEIGHT SPEAKER STAND	01-01-00-56310	CITY ADMINISTRATION	\$27.57
	638453469524	04/30/2023	BLUETOOTH PA SYSTEM	01-01-00-56310	CITY ADMINISTRATION	\$1,062.49
	* TAX CREDIT *	04/30/2023	* TAX CREDIT * ORIGINAL INVOICE #ZZ8810299	01-01-00-56310	CITY ADMINISTRATION	\$(12.50)
					<b>VENDOR TOTAL:</b>	<b>\$1,290.01</b>
<b>GRAND TOTALS:</b>						<b>\$3,032,977.15</b>



## City Council

### Agenda Memorandum

Item # AT-1

**To:** Mayor & City Council

**From:** Sonni Williams, City Attorney

**Subject:** Amendment to Chapter 111 of the City's Liquor Code Amending Class M (Haunted House/Paint Ball), Class N (Truck Stops), Increase the Caps on Class M and N, and Class N Prohibit the Sale of Mini-Sized Packaged Liquor

**Date:** Wednesday, May 17, 2023

#### **BACKGROUND/HISTORY**

Amendment to Class M liquor license class is to address the request from the State Liquor Control Commission for the Haunted House and the Paint Ball facility located off of Canal St. to have two separate liquor licenses instead of operating under one liquor license. Ordinance No. 23-016 will reduce the annual license fee by half since the Haunted House and the Paintball facility should not be economically penalized for the artificial separation of their liquor license into two separate licenses. In addition, the cap on Class M would need to be increased from one to two.

Class N was created to allow for the retail sale of beer and wine at large truck stops by the City council for the proposed development at the southeast corner of 159th St. and Gougar Rd. (Thorntons) and at the southwest corner of 143rd Street & Gougar Rd. (Gas N Wash) near the Heritage Crossing Business Park. Class N is limited to truck stops as defined by the Illinois Video Gaming Act that were allowed with local approval to have video gaming terminals without the requirement of on-site consumption liquor license. Subsequent to the creation of new Class N liquor license for Truck Stops, the City Council recently approved the concept plan for a gas station with convenience store that has diesel island with separate pumps on the northeast corner of Archer Ave. and 151st St. The developer of this gas station with diesel island will invest private dollars into extending water/sewer service line across Archer Ave. to allow a connection for the American Legion. The 151st location will not have gaming as the lot is too small to meet guidelines for gaming license without a "pour" liquor license.

Since the convenience store is a larger portion of their business and to assist the owner/developer to recoup the private investment to expand service connection, the City and owner/developer will have an agreement for the sharing of motor fuel tax generated from the

proposed gas station, the owner/developer has requested the ability for a full range of retail sale of packaged liquor for off-site consumption. Currently, Class N liquor license for large and regular truck stops is limited to the retail sale of beer and wine only. There will be no video gaming at the gas station and convenience store establishment off of Archer Ave. and 151st St. since Class N only allows sale of packaged liquor for off site consumption. The Illinois Video Gaming Act only allows liquor licensed establishments with a "pour" (allows for on-site consumption of alcohol) liquor license to have video gaming terminals. The exception to this restriction is for trucks stops (Thornton's and Gas N Wash), but the gas station with convenience store off of Archer Ave. and 151st does not meet the full definition of a truck stop since the property is less than 3 acres.

The American Legion and any other commercial development on the west side of Archer would benefit from the private investment in extending the service line across Archer Ave. and the convenience sale of a full range of packaged alcoholic liquor will not have a discernible negative impact in the surrounding neighboring residents nor the other larger convenience store centers at the two other truck stops.

Base on the feedback from members of the City Council, the prohibition on the retail sale of alcoholic liquor in mini-bottles less than 3 ounces will only apply to Class N liquor establishments, truck stops. These mini-bottles that are less than 3 ounces are popular items to buy at liquor and convenient stores, but once consumed, the empty mini-bottles are often times discarded and littered on the ground which then become eye-sores and have a deleterious impact on the community.

### **PROS/CONS/ALTERNATIVES**

Ordinance No. 23-016 amending the City's Liquor Code will address changes to Class M and N to facilitate the need for the Haunted House and Paintball facility operator to have separate licenses and to facilitate the private investment in extending the service line across Archer Ave. The prohibition of the retail sale of packaged mini-containers of alcohol only at truck stops will help curb the unsightly littering of any mini-bottles in the city.

### **RECOMMENDATION**

Approve Ordinance No. 23-016 amending Class M (Haunted House/Paint Ball) and Class N (Truck Stops), and prohibition on mini-sized liquor at Class N truck stop establishments.

### **ATTACHMENTS**

[Ordinance No. 23-016 Amendment to Class M \(haunted house\) & Class N \(truck stops\) and Increase in Caps](#)

### **SPECIFIC CITY COUNCIL ACTION REQUIRED**

Approve Ordinance No. 23-016 amending Chapter 111 of the Lockport Code of Ordinances related to Class M, Class N, increase the cap on Class M & Class N Liquor Licenses

**ORDINANCE NO. 23-016**

**AN ORDINANCE AMENDING CHAPTER 111 OF THE LOCKPORT CODE OF ORDINANCES  
RELATED TO CLASS M, CLASS N, INCREASE THE CAP ON CLASS M AND N LIQUOR  
LICENSES, AND PROHIBITION OF THE SALE OF MINI-SIZED ALCOHOLIC LIQUOR**

**Published in pamphlet form by authority of the Mayor  
and the City Council of the City of Lockport, Will County, Illinois,  
this \_\_\_ day of \_\_\_\_\_, 2023.**

ORDINANCE NO. 23-016

**AN ORDINANCE AMENDING CHAPTER 111 OF THE LOCKPORT CODE OF ORDINANCES RELATED TO CLASS M, CLASS N, INCREASE THE CAP ON CLASS M AND N LIQUOR LICENSES, AND PROHIBITION OF THE SALE OF MINI-SIZED ALCOHOLIC LIQUOR**

---

**WHEREAS**, the City of Lockport is a home-rule municipality pursuant to Article VII, Section 6 of the Illinois Constitution of 1970; and

**WHEREAS**, Section 4-1 of the Illinois Liquor Control Act confers the power to the City of Lockport by general ordinance or resolution to determine the number, kind and classification of licenses, for sale at retail of alcoholic liquor not inconsistent with this Act, 235 ILCS 5/4-1;

**NOW, THEREFORE**, be it ordained by the Mayor and the City Council of Lockport, Will County, Illinois, as follows:

**SECTION 1:** Chapter 111 of the Lockport Municipal Code is hereby amended by adding the following underlined words and deleting the stricken words:

**§ 111.08 LICENSE FEES.**

Every person, firm, or corporation engaged in the retail sale of alcoholic liquor in the city shall pay an annual license fee. Such licenses shall be divided into the following classes:

\*\*\*

(Q) Class M.

(1) Class M license shall authorize the retail sale of alcoholic liquor for consumption on the premises and shall permit entertainment on the premises for indoor or outdoor events open to the public or to invitees. This license shall only be applicable to events held on a publicly owned property. The annual fee for such license shall be \$1,000~~500~~, payable in two installments of \$500~~250~~ each, the first installment of which shall be deposited with the application for a license and the second installment to be due and payable on June 30 or December 31, whichever occurs first.

\*\*\*

(R) Class N.

(1) Class N license shall be authorized for an establishment regardless of whether such establishment has obtained approval by the Illinois Gaming Board for the operation of video gaming terminals whose operation or proposed operation meets the definition of:

(a) **LICENSED TRUCK STOP ESTABLISHMENT** as defined by the Illinois Video Gaming Act, 230 ILCS 40/5, to mean a facility (i) that is at least a 3-acre facility with a convenience store, (ii) with separate diesel islands for fueling commercial motor

vehicles, (iii) that sells at retail more than 10,000 gallons of diesel or biodiesel fuel per month, and (iv) with parking spaces for commercial motor vehicles. **COMMERCIAL MOTOR VEHICLES** has the same meaning as defined in Section 18b-101 of the Illinois Vehicle Code. The requirement of item (iii) of this paragraph may be met by showing that estimated future sales or past sales average at least 10,000 gallons per month; or

(b) **LICENSED LARGE TRUCK STOP ESTABLISHMENT** as defined by the Illinois Video Gaming Act, 230 ILCS 40/5, to mean a facility located within 3 road miles from a freeway interchange, as measured in accordance with the Department of Transportation's rules regarding the criteria for the installation of business signs: (i) that is at least a 3-acre facility with a convenience store, (ii) with separate diesel islands for fueling commercial motor vehicles, (iii) that sells at retail more than 50,000 gallons of diesel or biodiesel fuel per month, and (iv) with parking spaces for commercial motor vehicles. **COMMERCIAL MOTOR VEHICLES** has the same meaning as defined in Section 18b-101 of the Illinois Vehicle Code. The requirement of item (iii) of this paragraph may be met by showing that estimated future sales or past sales average at least 50,000 gallons per month-, or

(c) **TRUCK STOP ESTABLISHMENT WITH NO VIDEO GAMING** means a facility (i) that is at least a 1.5-acre gas station facility with fuel pumps and a convenience store with (ii) a separate diesel island for fueling commercial motor vehicles.

(2) Class N license shall authorize the retail sale of packaged alcoholic liquor with the following restrictions: (i) beer (not separated from original packaging) and no alcohol shall be sold packaged in mini-sized alcoholic liquor less than 3 ounces regardless of whether sold in an individual single bottle or in bulk packing of the mini-sized alcoholic liquor-wine only.

(3) No alcoholic beverages can be consumed on the premises or in the parking lot.

(4) The hours of sales for the retail sale of packaged beer (not separated from original packaging) and wine shall be sold during hours in compliance with the hours for the sale of liquor as prescribed under § 111.15 CLOSING HOURS of this Chapter.

(5) The annual fee for Class N liquor license shall be \$1,500 which may be payable in two installments of \$750 each. The first installment of \$750 shall be deposited with the application for a license and second installment to be due and payable on June 30 or December 31, whichever occurs first.

\*\*\*

#### § 111.11 LIMITATION OF CLASSES OF LIQUOR LICENSES.

\*\*\*

(L) The combined total of Class M license issued by the Local Liquor Commissioner shall not exceed ~~one~~two.

(M) The combined total of Class N licenses issued by the Local Liquor Commissioner shall not exceed ~~two~~three.

\*\*\*

**SECTION 2:** All ordinances, resolutions, orders, or parts thereof, which conflict with the provisions of this Ordinance, to the extent of such conflict, are hereby repealed.

**SECTION 3:** This Ordinance shall be in full force and effect from its passage and approval as provided by law.

**PASSED** this \_\_\_\_\_ day of \_\_\_\_\_, **2023**, with

\_\_\_\_\_ **ALDERMEN** voting aye      \_\_\_\_\_ **ALDERMEN** abstaining

\_\_\_\_\_ **ALDERMEN** voting nay      \_\_\_\_\_ **ALDERMEN** absent

The **MAYOR** voting aye \_\_\_\_\_, voting nay \_\_\_\_\_, not voting \_\_\_\_\_

\_\_\_\_\_ **BARTELSEN** \_\_\_\_\_ **BERGBOWER** \_\_\_\_\_ **GILLOGLY** \_\_\_\_\_ **KAIRIS**

\_\_\_\_\_ **DESKIN** \_\_\_\_\_ **PUGH** \_\_\_\_\_ **SABAN** \_\_\_\_\_ **MCDONALD**

\_\_\_\_\_ **MAYOR**

\_\_\_\_\_  
**Steven Streit, Mayor**

**ATTEST:**

\_\_\_\_\_  
**Kathleen Gentile, City Clerk**



## City Council

### Agenda Memorandum

Item # CD-1

**To:** Mayor & City Council

**From:** Kimberly Phillips, City Planner

**Subject:** Special Use Permit to Allow Expansion of the Existing Lockport Cemetery for the Property Generally Located East of Madison Street and North of 7th Street

**Date:** Wednesday, May 17, 2023

#### **BACKGROUND/HISTORY**

The subject property has been the location of the Lockport Cemetery for many years, dating back to the early to mid 1800's. The property is currently zoned R1 Single Family Residential. A Cemetery is classified as a Special Use within the R1 zoning district according to the City's Use Classification Table. The existing cemetery "use" is currently deemed a non-conforming use as the property is not impressed with a special use permit. The applicant desires to acquire additional R1 zoned (city owned) property (north boundary) located at 412 Madison Street and consolidate the vacant parcel with the existing cemetery property. Upon consolidation/expansion the non-conforming cemetery will lose its "grandfathered use" status and require a special use permit.

This item went before the Plan and Zoning Commission at their regular scheduled meeting on April 11, 2023. Owners of neighboring properties were present to hear the case, however no one objected to the Special Use Permit.

#### **PROS/CONS/ALTERNATIVES**

N/A

#### **RECOMMENDATION**

The Plan and Zoning Commission voted to adopt Staff's Findings of Facts and recommend approval of the Special Use Permit for a Cemetery with a vote of 7:0.

#### **ATTACHMENTS**

[Ordinance No. 23-017 SUP Cemetery Expansion](#)

Exhibit A - Plat of Survey

Staff Memo SUP Cemetery

**SPECIFIC CITY COUNCIL ACTION REQUIRED**

Approve Ordinance No. 23-017 the Special Use Permit to allow the expansion of Lockport Cemetery.

**ORDINANCE NO. 23-017**

**AN ORDINANCE APPROVING A SPECIAL USE PERMIT TO ALLOW THE  
EXPANSION OF LOCKPORT CEMETERY**

**WHEREAS**, Lockport Cemetery Association is the owner of an approximate 10.4 (more or less) acres of generally located east of Madison Street and north of 7<sup>th</sup> Street having PIN 11-04-23-233-001-0000; hereby depicted as “**EXHIBIT A**;

**WHEREAS**, the Property is zoned R1 Single Family Residential, and is deemed “legal” nonconforming, as a Cemetery is classified as a Special Use within the R1 zoning District Pursuant to the Lockport Zoning Ordinance and the property is not impressed with a special use ; and

**WHEREAS**, the petitioner desires to expand the existing Cemetery to include the property located at 412 Madison Street having PIN 11-04-23-232-016-0000. The expansion will result in the loss of the “nonconforming” status; and

**WHEREAS**, the applicant has requested a Special Use Permit for a Cemetery within the R1 District to bring the existing Cemetery into conformance and include the newly acquired parcel; and

**WHEREAS**, a public hearing was held on April 11, 2023 before the Plan & Zoning Commission of the City of Lockport, with prior notice thereof given in the manner as provided in Section 11-13-6 and 11-13-7 of the Illinois Municipal Code to consider the Special Use Permit for a Cemetery with a vote of 7:0, recommended approval.

**WHEREAS**, the Plan and Zoning Commission of the City of Lockport found sufficient evidence that the Special Use Permit for a Cemetery, meets standards established for such classification in the ordinances, and the granting of permission therefor may be subject to conditions reasonably necessary to meet such standards, as required under 65 ILCS 5/11-13-1.1, and by a vote of 7-0, recommended approval

NOW, THEREFORE, BE IT ORDAINED BY THE MAYOR AND CITY COUNCIL OF THE CITY OF LOCKPORT, WILL COUNTY, ILLINOIS THAT:

**SECTION 1: INCORPORATION OF PREAMBLE AND EXHIBITS**

That the Preamble and all Exhibits to this Ordinance are incorporated herein as if fully set forth in this Section 1.

**SECTION 2: SPECIAL USE PERMIT FOR A CEMETERY**

A Special Use Permit is duly granted to the property described on “**EXHIBIT A**”.

**SECTION 3. SUCCESSOR**

This Ordinance shall be binding upon and in full force and effect with regard to any successors in interest to the applicant. Any such successor shall benefit from and be obligated to comply with all of the terms, requirements, limitations, and conditions set forth in this Ordinance as to any portion of the Property owned by it or in which it has any interest.

**SECTION 4. SEVERABILITY**

In the event any word, phrase, clause, sentence, paragraph, provision or section of this Ordinance, or any part thereof, shall be held to be unconstitutional, unenforceable or void, the same shall not affect the validity or enforceability of any remaining words, phrases, clauses, sentences, paragraphs, provisions or sections of this Ordinance.

**SECTION 5. REPEALER**

All ordinances or parts of ordinances conflicting with any provisions of this ordinance are hereby repealed.

**SECTION 6. EFFECTIVE DATE**

This Ordinance shall be effective after its passage, approval and publication in pamphlet form as provided by law.

**PASSED** this \_\_\_\_\_ day of \_\_\_\_\_, 2023, with

\_\_\_\_\_ALDERMEN voting aye      \_\_\_\_\_ALDERMEN abstaining

\_\_\_\_\_ALDERMEN voting nay      \_\_\_\_\_ALDERMEN absent

the MAYOR voting aye \_\_\_\_\_, voting nay \_\_\_\_\_, not voting \_\_\_\_\_

\_\_\_\_\_ SABAN    \_\_\_\_\_MCDONALD    \_\_\_\_\_ BERGBOWER    \_\_\_\_\_GILLOGLY

\_\_\_\_\_PUGH    \_\_\_\_\_KAIRIS    \_\_\_\_\_DESKIN    \_\_\_\_\_BARTELTSEN

\_\_\_\_\_MAYOR

\_\_\_\_\_

**Steven Streit, Mayor**

ATTEST:

\_\_\_\_\_

Kathleen Gentile, City Clerk

# PLAT OF LEGAL DESCRIPTION

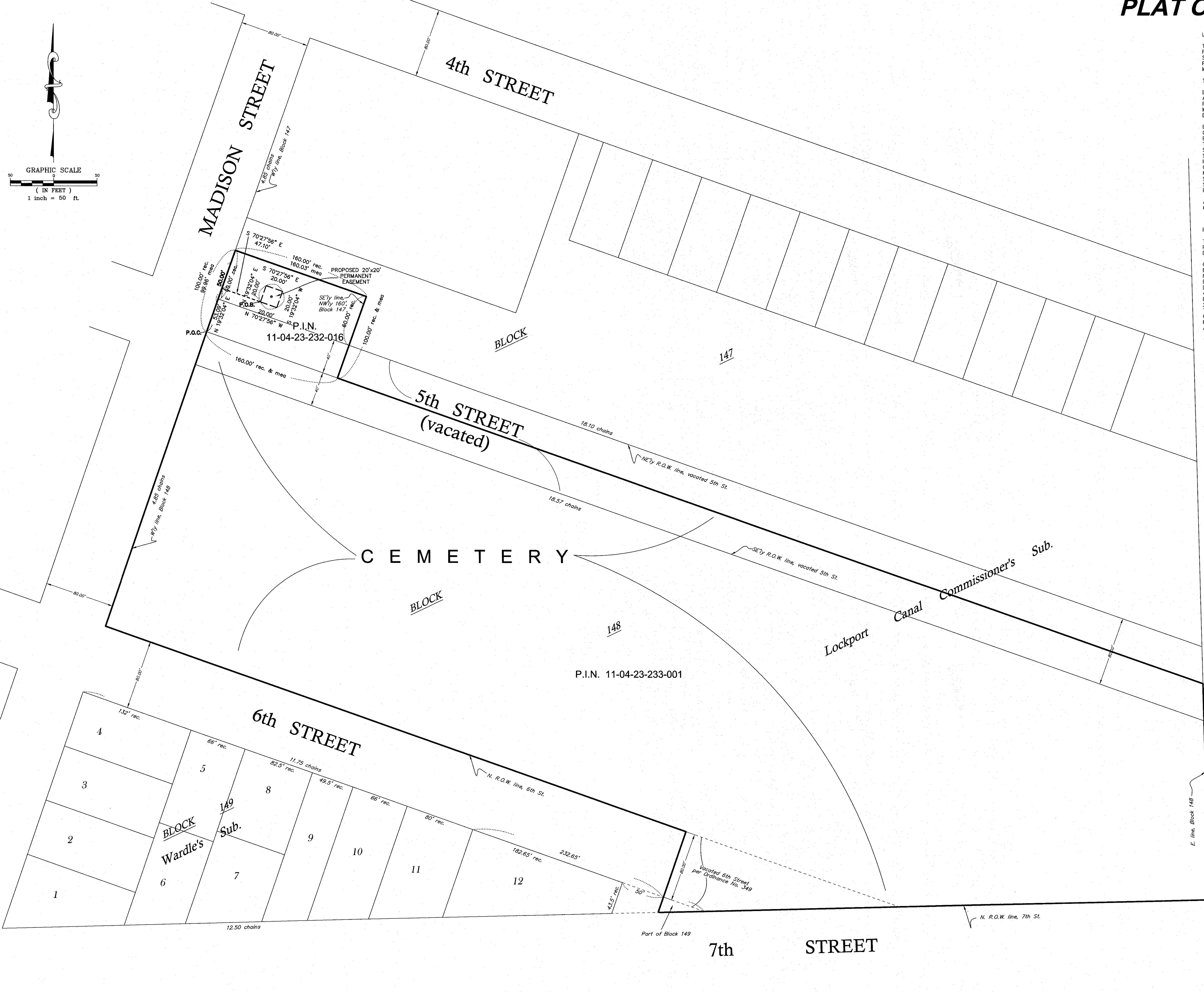
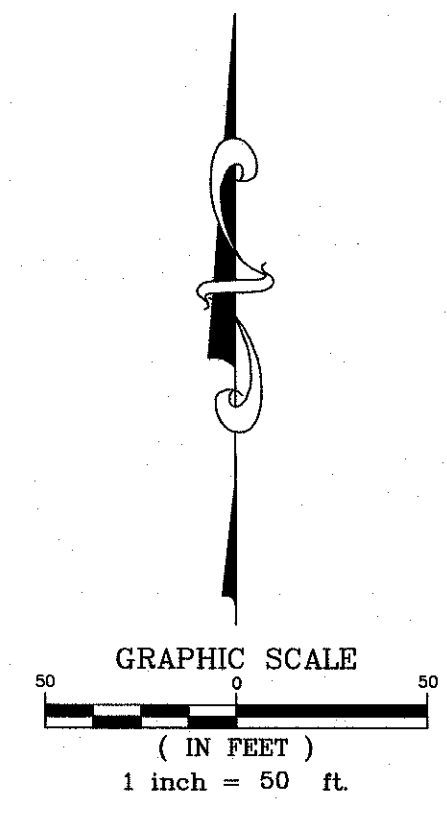

**LEGAL DESCRIPTION**

THE SOUTHWESTERLY 60 FEET OF THE NORTHWESTERLY 160 FEET OF BLOCK 147 TOGETHER WITH THAT PART OF THE NORTH HALF OF VACATED 5TH STREET LYING SOUTHWESTERLY OF AND ADJACENT TO SAID NORTHWESTERLY 160 FEET IN LOCKPORT CANAL COMMISSIONER'S SUBDIVISION, A SUBDIVISION OF PART OF SECTION 23, IN TOWNSHIP 36 NORTH, AND IN RANGE 10 EAST OF THE THIRD PRINCIPAL MERIDIAN,

TOGETHER WITH:

BLOCK 148, AND ALSO THE SOUTH HALF OF VACATED 5TH STREET LYING NORTHEASTERLY OF AND ADJACENT TO SAID BLOCK 148 IN LOCKPORT CANAL COMMISSIONER'S SUBDIVISION, A SUBDIVISION OF PART OF SECTION 23, IN TOWNSHIP 36 NORTH, AND IN RANGE 10 EAST OF THE THIRD PRINCIPAL MERIDIAN, ALSO THAT PART OF VACATED 6TH STREET PER CITY OF LOCKPORT ORDINANCE NO. 349 DESCRIBED AS FOLLOWS:

BEGINNING AT A POINT IN THE SOUTHERLY LINE OF SAID 6TH STREET AT A POINT IN THE NORTH LINE OF LOT 12 IN WARDLE'S SUBDIVISION OF BLOCK 149 IN THE CITY OF LOCKPORT WHICH IS 232.65 FEET EASTERLY, MEASURED ALONG SAID NORTH LINE FROM THE NORTHWEST CORNER OF SAID LOT 12, THENCE NORTHERLY AT RIGHT ANGLES TO SAID NORTH LINE ACROSS SAID 6TH STREET TO THE SOUTHERLY LINE OF BLOCK 148 IN SAID CITY OF LOCKPORT, WHICH IS ALSO THE NORTHERLY LINE OF SAID 6TH STREET, THENCE EASTERLY ALONG SAID NORTHERLY LINE OF 6TH STREET, TO THE POINT OF INTERSECTION WITH THE NORTH LINE OF THE PUBLIC HIGHWAY AS LAID OUT ON THE EAST AND WEST CENTER LINE OF SECTION 23 IN TOWNSHIP 36 NORTH, IN RANGE 10 EAST OF THE THIRD PRINCIPAL MERIDIAN, THENCE WEST ALONG THE NORTH LINE OF SAID PUBLIC HIGHWAY TO THE EAST CORNER OF SAID LOT 12 IN WARDLE'S SUBDIVISION OF BLOCK 149 AS AFORESAID, THENCE WESTERLY ALONG THE SOUTHERLY LINE OF SAID 6TH STREET WHICH IS ALSO THE NORTHERLY LINE OF SAID LOT 12, TO THE PLACE OF BEGINNING,

AND ALSO THAT PART OF BLOCK 149 LYING SOUTHWESTERLY OF AND ADJACENT TO SAID VACATED 6TH STREET, ALL IN WILL COUNTY, ILLINOIS.

**PROPOSED PERMANENT EASEMENT**

THAT PART OF BLOCK 147 IN LOCKPORT CANAL COMMISSIONER'S SUBDIVISION, A SUBDIVISION OF PART OF SECTION 23, IN TOWNSHIP 36 NORTH, RANGE 10 EAST OF THE THIRD PRINCIPAL MERIDIAN, DESCRIBED AS FOLLOWS:

COMMENCING AT THE INTERSECTION OF THE WESTERLY LINE OF SAID BLOCK 147, SAID WESTERLY LINE BEING THE EASTERLY RIGHT OF WAY LINE OF MADISON STREET WITH THE SOUTHERLY LINE OF THE NORTHERLY HALF OF VACATED 5TH STREET; THENCE NORTH 19 DEGREES 32 MINUTES 04 SECONDS EAST, ON THE EASTERLY RIGHT OF WAY LINE OF MADISON STREET, 53.09 FEET; THENCE SOUTH 70 DEGREES 27 MINUTES 56 SECONDS EAST, PERPENDICULAR TO SAID EASTERLY RIGHT OF WAY LINE, 47.10 FEET TO THE POINT OF BEGINNING; THENCE NORTH 19 DEGREES 32 MINUTES 04 SECONDS EAST, PARALLEL WITH SAID EASTERLY RIGHT OF WAY LINE, 20.00 FEET; THENCE SOUTH 70 DEGREES 27 MINUTES 56 SECONDS EAST, PERPENDICULAR TO SAID EASTERLY RIGHT OF WAY LINE, 20.00 FEET; THENCE SOUTH 19 DEGREES 32 MINUTES 04 SECONDS WEST, PARALLEL WITH SAID EASTERLY RIGHT OF WAY LINE, 20.00 FEET; THENCE NORTH 70 DEGREES 27 MINUTES 56 SECONDS WEST, PERPENDICULAR TO SAID EASTERLY RIGHT OF WAY LINE, 20.00 FEET TO THE POINT OF BEGINNING, ALL IN WILL COUNTY, ILLINOIS.

- LEGEND**
- mea. MEASURED
  - rec. RECORDED
  - calc. CALCULATED
  - FOUND SURVEY MONUMENT
  - SET 5/8" REBAR UNLESS OTHERWISE NOTED

STATE OF ILLINOIS }  
 COUNTY OF WILL } SS

RUETTIGER, TONELLI & ASSOCIATES, INC., ILLINOIS PROFESSIONAL DESIGN FIRM No. 184-001251, DOES HEREBY CERTIFY THAT THIS PLAT OF LEGAL DESCRIPTION WAS PREPARED UNDER ITS DIRECTION AND BASED ON EXISTING SURVEY INFORMATION.

I, *[Signature]*, PROFESSIONAL LAND SURVEYOR, DO HEREBY CERTIFY BY MY HAND AND SEAL THIS 10<sup>th</sup> DAY OF March, 2023.

STATE OF ILLINOIS PROFESSIONAL LAND SURVEYOR (MY LICENSE EXPIRES 11-30-2024)

DESIGN FIRM OR PROFESSIONAL LICENSEE WHO PREPARED THIS DRAWING.

REVISIONS			
No.	DATE	DESCRIPTION	BY

**RT & A** Ruettiger, Tonelli & Associates, Inc.  
 Surveyors • Engineers • Planners • Landscape Architects • GIS Consultants  
 129 CAPISTA DRIVE • SHOREWOOD, ILLINOIS 60404  
 PH. (815) 744-6600 FAX (815) 744-0101  
 website: www.ruettigertonnelli.com

DATE: 02/22/2023 SCALE: 1" = 50' DRAWN BY: TW CHECKED BY: KP  
 PREPARED FOR: CITY OF LOCKPORT 222 E. 9TH STREET LOCKPORT, ILLINOIS 60441  
 FIELD BOOK: PAGE: DRAWING No.: 318-0091-LD  
 DRAWING TITLE: PLAT OF LEGAL DESCRIPTION



**Planning and Zoning Memorandum**

**Case #2023-004**

TO: Plan and Zoning Commission  
FROM: Kimberly Phillips, City Planner  
DATE: April 4, 2023  
SUBJECT: Special Use Permit to allow Expansion of the existing Lockport Cemetery for the property generally located East of Madison Street and North of 6<sup>th</sup> Street and 7<sup>th</sup> Street.

**I. SUMMARY/REQUESTED ACTION**

The applicant, Lockport Cemetery Association, is seeking approval of a Special Use Permit for a Cemetery to allow expansion by acquiring the property located at 412 Madison Street.

A Special Use Permit requires public hearing. Notification of the public hearing is necessary in three (3) ways: newspaper ad, mailings to property owners within 250 feet of the subject property, and installation of a sign along State Street. All requirements have been completed by City staff.

**II. GENERAL INFORMATION**

- 1) **Meeting Date:** April 11, 2023
- 2) **Applicant:** Lockport Cemetery Association
- 3) **Location:** 412 & 528 Madison St. Lockport IL 60441
- 4) **PIN Number(s):** 11-04-23-233-001-0000, 11-04-23-232-016-0000
- 5) **Parcel Sizes:** .5 acres
- 6) **Zoning and Land Use:** R1 – Single Family Residential
- 7) **Surrounding Zoning and Land Use:**

+	Zoning	Jurisdiction	Use
North	R1	City of Lockport	Residential
West	R1	City of Lockport	Residential
South	R1 C2	City of Lockport	Residential/School Commercial
East	R1	City of Lockport	Residential

### III. PROJECT OVERVIEW

---

The subject property consists of approximately 0.5 acres and has been the location of the Lockport Cemetery for many years, dating back to the early-mid 1800's.

The property is currently zoned R1 Single Family Residential. A Cemetery is classified as a Special Use within the R1 zoning district according to the City's Use Classification Table. The existing cemetery "use" is currently deemed a non-conforming use as the property is not impressed with a special use permit. The applicant desires to acquire additional R1 zoned (city owned) property (north boundary) located at 412 Madison Street and consolidate the vacant parcel with the existing cemetery property. Upon consolidation/expansion the non-conforming cemetery will lose its "grandfathered use" status and require a special use permit.



### III. SPECIAL USE PERMIT FOR CEMETERY

---

**Findings of Fact - Section 156.122 - Special Use Standards.** A special use permit shall be granted only if evidence is presented to establish the following:

- (A) *The proposed building or use at the particular location requested is necessary or desirable to provide a service or facility which is in the interest of the public and will contribute to the general welfare of the neighborhood or community.*

The Cemetery has been in existence for many years and currently does not have remaining space. The expansion is in the interest of the public.

- (B) *The proposed building or use will not have a substantial adverse effect upon the adjacent property, the character of the neighborhood, traffic conditions, utility facilities and other matters affecting the public health, safety and general welfare.*

The use should not have adverse effect upon adjacent property.

- (C) *The proposed building or use will be designed, arranged and operated so as to permit the development and use of the neighboring property in accordance with the applicable district regulations.*

There is no new development in this area.

#### **IV. RECOMMENDED MOTION**

---

Should the Commission find the Special Use Permit for a Cemetery to allow expansion, the following motion is suggested:

- A. A motion to adopt the findings of facts as presented by staff to make recommendation of approval of the Special Use Permit for a Cemetery within the R1 Single Family Residential District:

#### **V. ATTACHMENTS**

---

1. Plat of Survey