



Regular Governing Body Meeting
City of Rio Rancho
AGENDA
April 10, 2025
6:00 PM
Council Chambers

Governing Body Members

Greggory D. Hull, Mayor	Paul Wymer, Councilor District 4
Deb Dapson, Councilor District 1	Karissa Culbreath, Councilor District 5
Jeremy Lenentine, Councilor District 2	Nicole List, Councilor District 6
Bob Tyler, Councilor District 3	

Meeting Information

This meeting will be conducted in-person and virtually, as well as, streamed live on the City of Rio Rancho website at <https://rrnm.gov/2303/Watch-and-Download-City-Meetings>

Join by Computer: <https://us06web.zoom.us/j/83338157719?pwd=ST55whY8GCTELqBoGjYG1ipM1F5Uer.1>

Meeting ID: 833 3815 7719

Passcode: 554297

Join by Phone:

Dial +1 720 707 2699 US (Denver)

Pursuant to the Governing Body Rules of Procedures, any person wishing to address the Governing Body related to an item listed under Second Reading of Ordinances, First Reading of Ordinances, or Discussion and Deliberation, shall register in person with the City Clerk no later than fifteen (15) minutes prior to the scheduled start time of a meeting. No more than two (2) hours in total will be allotted for comments pertaining to a specific agenda item at any meeting. A majority vote of the Governing Body members present may approve to extend the total amount of time allotted for public input related to a specific agenda item at a meeting.

Public input can be submitted in writing to the City Clerk, as clerk of the Governing Body, prior to the date of the meeting in which the item is scheduled to be heard; however, only public input received before 4 p.m. on the day of the meeting will be entered into the record prior to the meeting.

Call to Order and Pledge of Allegiance

Proclamations and Awards of Merit

Public Forum

Pursuant to the Governing Body Rules of Procedure, any person wishing to address the Governing Body related to a non-agenda item shall register in person with the City Clerk no later than fifteen (15) minutes prior to the scheduled start time of a meeting. No more than two (2) hours in total will be allotted for public forum comments at any meeting. A majority vote of the Governing Body members present may approve to extend the total amount of time allotted for public forum at a meeting.

Comments by Councilors

Consent Calendar

There will be no discussion of these items unless a Governing Body Member so requests, in which event the item will be moved to a discussion item on the regular agenda.

- 1 Minutes of March 27, 2025 Regular Meeting
Minutes of March 27, 2025 Regular Meeting
- 2 D18, Appointment of Tyler Dunkel to the Lodger's Tax Advisory Board
T. Dunkel Resume
- 3 D19, Appointment of Lanny Busher to the Keep Rio Rancho Beautiful Committee
L. Busher Resume
- 4 D20, Appointment of Jonathan Romero to the Parks and Recreation Commission
J. Romero Resume

Boards/Commissions/Committee Reports

Public Hearings

- 5 D21, Approval for Ragarm Development Company, LLC, DBA Betty's Revel Burger, (the "Applicant") Located at 300 Unser Blvd. SE, Rio Rancho, NM 87124 for Transfer of New Mexico Dispenser License DIS-001034 with On Premises Consumption Only to Include Patio Service
*Betty's Revel Burger
Notification of Withdrawn Application*
- 6 D22, Site Plan Approval for an Extended Stay Hotel at the Property Legally Described as High Resort Market Place, Block A, Tract B1
*Application
Authorization
Zoning, Location
Staff Comments
Site Plan, Utilities
Landscape Plan
Elevations
Reproduction of Notices
PZB- Zoning Interpretation, Ordinance 86-002*

Second Reading of Ordinances

First Reading of Ordinances

Discussion and Deliberation

- 7 R35, Resolution Amending the Permanent Fund Investment Policy Statement
*Resolution_R35
2025 Rio Rancho IPS - Revision
2024 Rio Rancho IPS - Revision*

City Manager

Adjournment

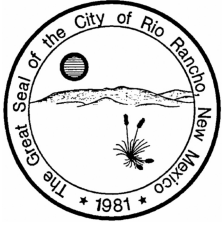

**CITY OF RIO RANCHO
COVER PAGE**

Legislation Item:

AGENDA DATE:
April 10, 2025

DEPARTMENT:
City Clerk

SUBJECT:
Minutes of March 27, 2025 Regular Meeting

BACKGROUND AND ANALYSIS:

IMPACT:

ALTERNATIVES:

DEPARTMENT RECOMMENDATION:

ATTACHMENT: [Minutes of March 27, 2025 Regular Meeting](#)



Governing Body
of the
City of
Rio Rancho
MINUTES
MARCH 27, 2025
6:00 p.m.
Council Chambers

MEMBERS PRESENT:

Greggory D. Hull, Mayor (virtual)
Deb Dapson, Councilor Dist. 1
Jeremy Lenentine, Deputy Mayor, Dist. 2
Bob Tyler, Councilor Dist. 3 (virtual)
Paul Wymer, Councilor Dist. 4
Karissa Culbreath, Councilor Dist. 5
Nicole List, Councilor Dist. 6

STAFF

Matt Geisel, City Manager
Peter Wells, Deputy City Manager
Josh Rubin, City Attorney
Noel Davis, City Clerk
Carol Jaramillo, Director of Financial Services
Connie Peterson, Director of Parks, Rec. & Comm. Services
James DeFillippo, Fire Chief
Stewart Steele, Police Chief
Steve Gallegos, Acting Utilities Director
Yolanda Lucero, Deputy City Clerk

Call to Order and Pledge of Allegiance

Deputy Mayor Lenentine called the meeting to order at 6:00 p.m.

Deputy Mayor Lenentine stated he will be presiding over the meeting this evening as Mayor Hull is traveling and will be in attendance remotely.

Proclamations and Awards of Merit

Public Forum

The following individual spoke under Public Forum:

- Kristelle Siarza Moon

Comments by Councilors

Deputy Mayor Lenentine stated he will be moving O7 to be heard directly after the Consent Calendar and R34, to be heard directly after Public Hearing D17, if there are no objections. There were no objections.

Consent Calendar

- 1) Minutes of March 13, 2025 Regular Meeting
- 2) R28, Resolution Authorizing a Budget Adjustment to the Recreation Activities Fund (206)
- 3) R29, Resolution Authorizing the Disposal of Senior Services Division Property

- 1 4) R30, Resolution Authorizing a Budget Adjustment to the General Fund (101)
2 5) R31, Resolution Authorizing a Budget Adjustment to the Drainage Impact Fee Fund
3 (355)
4 6) R32, Resolution Authorizing Disposal of Library and Information Services Department
5 Property
6 7) R33, Resolution Authorizing a Budget Adjustment to the Senior Center Programs
7 Fund (216)

8
9 Deb Dapson moved to approve consent calendar. Seconded by Nicole List

10
11 The motion carried by a vote of 6 FOR and 0 AGAINST.

12 YES: Deb Dapson, Jeremy Lenentine, Bob Tyler, Paul Wymer, Karissa

13 Culbreath, Nicole List

14 NO: None

- 15
16 8) O7, Ordinance Amending Chapter 51 Water and Wastewater Rules and Rates

17
18 Steve Gallegos, Acting Utilities Director presented this item. This is the second reading
19 requesting a rate adjustment. The rates proposed will ensure the Utilities Department
20 has the revenue required to maintain and operate a safe and reliable water and
21 wastewater system.

22
23 Karissa Culbreath moved to approve O7. Seconded by Nicole List

24
25 The motion carried by a vote of 5 FOR and 1 AGAINST.

26 YES: Deb Dapson, Jeremy Lenentine, Paul Wymer, Karissa Culbreath, Nicole

27 List

28 NO: Bob Tyler

29
30 Mayor Hull left the meeting at 6:18 p.m.

31
32 **Boards/Commissions/Committee Reports**

33
34 **Public Hearings**

- 35
36 9) D17, Public Hearing for Community Development Block Grant (CDBG) Proposed
37 Amendment to Action Plans 2018, 2019, and 2022

38
39 Deputy Mayor Lenentine opened this item up for public hearing. No individual spoke on
40 this item.

41
42 **Discussion and Deliberation**

- 43
44 10) R34, Resolution Authorizing Community Development Block Grant (CDBG)
45 Substantial Amendment and a Budget Adjustment to the CDBG Fund (375)

1 Carole Jaramillo, Director of Financial Service presented this item. The Resolution
2 adopts the proposed amendment to reallocate \$25,971.44 of Federal Community
3 Development Block Grant funds, primarily from the Down Payment Assistance Program,
4 to the Safelight Boulevard ADA Ramp Remediation project. The funds will be
5 reallocated to fully fund ADA Ramp Remediation and to fully expend CDBG funds from
6 Program Year 2018, which will expire on September 27, 2025. Funds will be reallocated
7 within the CDBG Fund (375) with no impact to the General Fund.

8
9 Deb Dapson moved to approve R34. Seconded by Karissa Culbreath

10
11 The motion carried by a vote of 6 FOR and 0 AGAINST.

12 YES: Deb Dapson, Jeremy Lenentine, Bob Tyler, Paul Wymer, Karissa

13 Culbreath, Nicole List

14 NO: None

15
16 **Second Reading of Ordinances**

17
18 11) O6, Ordinance Authorizing the Issuance and Sale of the City of Rio Rancho, New
19 Mexico Gross Receipts Tax Improvement Revenue Bonds, Series 2025 in an Aggregate
20 Principal Amount Not to Exceed \$32,000,000 (Excluding Premium, if any, Paid in
21 Connection with the Original Purchase of the Bonds) for the Purposes of Paying Costs
22 of (1) the Design, Construction, Acquisition, Installation and Equipping of (a) Road and
23 Street Improvements and Related Utility Infrastructure Within the City, and (b) City
24 Buildings and Public Facilities, (2) the Funding of a Debt Service Reserve Fund, to the
25 Extent Applicable, and (3) Expenses Relating to the Issuance of the Bonds; Approving
26 the Form of and Other Details Concerning the Bonds, Including but not Limited to
27 Covenants and Agreements in Connection with the Bonds; Providing for the Payment of
28 the Principal of, Interest, and Premium, if Any, on the Bonds; Providing that Bonds will
29 be Payable from Certain Gross Receipts Taxes Distributed to the City; Delegating
30 Authority to Certain Authorized Officers of the City to Determine the Final Terms and
31 Related Features of the Bonds Pursuant to Section 6-14-10.25 NMSA 1978; Ratifying
32 Action Previously Take in Connection Therewith; Repealing All Actions in Conflict
33 Herewith; and Authorizing the Taking of Other Actions in Connection with the Issuance
34 and Sale of the Bonds

35
36 Carole Jaramillo, stated this is the second reading. Adoption of the Ordinance will
37 enable the City to leverage Federal funding for the widening of Unser Boulevard from
38 Cherry Road to Paseo del Volcan, enable construction of Fire Station 8, and allow for
39 contingency and/or design of a multi-generational or other facility for the benefit of the
40 residents of the City. Debt service will come from the State Shared GRT (General Fund)
41 and has been programmed into the five-year financial plan.

42
43 Nicole List moved to approve O6. Seconded by Deb Dapson

44 The motion carried by a vote of 6 FOR and 0 AGAINST.

45 YES: Deb Dapson, Jeremy Lenentine, Bob Tyler, Paul Wymer, Karissa

46 Culbreath, Nicole List

1 NO: None

2
3 12) O8, Ordinance Amending Chapter 30 Governing Body, Chapter 31 City Officials, &
4 Chapter 34 Municipal Court

5
6 Peter Wells, Deputy City Manager presented this item. This is the second reading
7 proposing to amend Chapter 30, of the Municipal Code. The Municipal Judge annual
8 salary will be increased from \$70,000 to \$80,500 (15 percent) and take effect when the
9 next Municipal Judge begins a new four-year term in 2026. The Alternate Municipal
10 Judge salary will be increased by 14 percent, and take effect 10 days after adoption of
11 the Ordinance. Governing Body annual salary will be reflected by a numeric value as
12 opposed to State law reference in Municipal Code. The numeric values match changes
13 made in August 2024 by the Governing Body related to future (not current) elected
14 official compensation. An election for Mayor and three City Councilors is scheduled for
15 March 2026. Because Governing Body compensation is no longer tied to State law
16 related to County official compensation, which was adjusted periodically, a cost-of-
17 living/inflation increase of 8 percent applied every four years has been added.

18
19 Deb Dapson moved to approve O8. Seconded by Paul Wymer

20
21 The motion carried by a vote of 6 FOR and 0 AGAINST.

22 YES: Deb Dapson, Jeremy Lenentine, Bob Tyler, Paul Wymer, Karissa
23 Culbreath, Nicole List

24 NO: None

25
26 13) O9, Ordinance Amending Ordinance No. 8, Enactment No. 24-08 Relating to the
27 Issuance and Sale of City of Rio Rancho, New Mexico Taxable Industrial Revenue
28 Bonds (Quail Ranch Energy Storage LLC Project), in a Maximum Principal Amount of
29 up to \$140,000,000, for the Purpose of Updating and Approving the Annual Payments
30 In Lieu Of Taxes to the City of Rio Rancho, Rio Rancho Public Schools and
31 Albuquerque Public Schools in Conformity with the Requirements of Section 3-32-6
32 NMSA 1978; Authorizing Execution and Delivery of the Bonds with Updated Series
33 Designation to Reflect the Date of Issuance and Delivery; Ratifying Certain Actions
34 Taken Previously; and Repealing All Actions Inconsistent with this Ordinance

35
36 Albert Solis, Economic Development Manager presented O9 and O10 jointly. The
37 proposed ordinance will amend both Ordinances. The project intends to proceed with
38 issuing the Industrial Revenue Bonds within the next few months. As such, the Annual
39 Payments in Lieu of Taxes (PILOT) schedule shall be updated based on the Tax Year
40 2024 mill levies and most recent student enrollment data.

41
42 Karissa Culbreath moved to approve O9. Seconded by Deb Dapson

43 The motion carried by a vote of 6 FOR and 0 AGAINST.

44 YES: Deb Dapson, Jeremy Lenentine, Bob Tyler, Paul Wymer, Karissa
45 Culbreath, Nicole List

46 NO: None

1 14) O10, Ordinance Amending Ordinance No. 9, Enactment No. 24-09 Relating to the
2 Issuance and Sale of City of Rio Rancho, New Mexico Taxable Industrial Revenue
3 Bonds (Quail Ranch Solar LLC Project), in a Maximum Principal Amount of up to
4 \$110,000,000, for the Purpose of Updated and Approving the Annual Payments in Lieu
5 of Taxes to the City of Rio Rancho, Rio Rancho Public Schools and Albuquerque Public
6 Schools in Conformity with the Requirements of Section 3-32-6 NMSA 1978;
7 Authorizing Execution and Delivery of the Bonds with Updated Series Designation to
8 Reflect the Date of Issuance and Delivery; Ratifying Certain Actions Taken Previously;
9 and Repealing All Actions Inconsistent with this Ordinance

10
11 Deb Dapson moved to approve O10. Seconded by Nicole List

12
13 The motion carried by a vote of 6 FOR and 0 AGAINST.

14 YES: Deb Dapson, Jeremy Lenentine, Bob Tyler, Paul Wymer, Karissa
15 Culbreath, Nicole List

16 NO: None

17
18 **First Reading of Ordinances**

19
20 **City Manager**

21
22 Matt Geisel, City Manager highlighted the following events:

- 23
24 • Spring Vendor and Craft Fair on Saturday at Sabana Grande Recreation Center
25 • Loma Colorado Library an exhibition from 3/22 – 6/1 on Why We Serve: Native
26 Americans in the United States Armed Forces. Highlighting contributions Native
27 Americans have made to the US military throughout our country's history.
28 • Cabezon Park next Saturday will host a Shop Local Market.

29
30 **Adjournment**

31
32 6:31 p.m.

33
34
35 APPROVED THIS APRIL 10, 2025

36
37
38 _____
Greggory D. Hull, Mayor

39 ATTEST:

40
41 _____
42 Noel C. Davis, City Clerk
43 (SEAL)



**CITY OF RIO RANCHO
COVER PAGE**

Legislation Item: D18

AGENDA DATE:

April 10, 2025

DEPARTMENT:

Administration

SUBJECT:

D18, Appointment of Tyler Dunkel to the Lodger's Tax Advisory Board

BACKGROUND AND ANALYSIS:

The Lodger's Tax Advisory Board has several duties which include advising the Governing Body on the expenditure of funds generated by Lodger's Tax for advertising, publicizing, and promoting tourist attractions and facilities in the City and surrounding area.

The five-member board consists of two from the lodging industry, two from the tourism industry, and one member from the general public.

Dunkel is a Rio Rancho resident (City Council District 2) and currently serves on the board. If reappointed, he will fill a tourism seat on the board as a result of his employment with the New Mexico Activities Association.

Dunkel's term will expire on May 31, 2028.

IMPACT:

The appointment will fill a vacancy on the Lodger's Tax Advisory Board caused by term expiration (May 2025).

ALTERNATIVES:

Approve the appointment.

Do not approve the appointment.

DEPARTMENT RECOMMENDATION:

Mayor Hull recommends the reappointment of Tyler Dunkel to the Lodger's Tax Advisory Board.

ATTACHMENT: [T. Dunkel Resume](#)

Tyler Dunkel is a native of Parker, Colorado but has lived in New Mexico for over 23 years and has been an athletics administrator for nearly 27 year.

He spent his first 14 years in the Land of Enchantment in Las Cruces, N.M., working for the New Mexico State Athletics Department, first as the Assistant Director of Media Relations, then as an Assistant Athletic Director of Media Relations, overseeing all aspect of media relations and communications for the Aggies' athletic department.

In 2014, Dunkel accepted a position with the New Mexico Activities Association in Albuquerque, N.M., as an Assistant Director of Sports. The NMAA is the governing body for High School Sports and Activities for the State of New Mexico. At the NMAA, Dunkel is the baseball & football liaison for the State, while also handling the office social media accounts and website.

Tyler and his wife Gloria have been married for over20 years and have three children, Jacob (32), Cole (19) and Isabella (15 - a freshman at Cleveland in Rio Rancho). Dunkel and his family have lived in Rio Rancho since 2017.

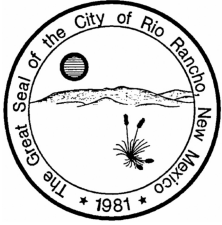

**CITY OF RIO RANCHO
COVER PAGE**

Legislation Item: D19

AGENDA DATE:

April 10, 2025

DEPARTMENT:

Administration

SUBJECT:

D19, Appointment of Lanny Busher to the Keep Rio Rancho Beautiful Committee

BACKGROUND AND ANALYSIS:

The committee works to improve the quality of life in the community with specific focus in the areas of recycling, litter prevention, beautification, environmental education, and solid waste handling practices.

Busher resides in City Council District 6 and currently serves on the board. If reappointed (District 6 seat), Busher will serve a term that expires on April 28, 2028.

IMPACT:

The appointment will fill a vacancy on the Keep Rio Rancho Beautiful Committee caused by term expiration (April 2025).

ALTERNATIVES:

Approve the appointment.

Do not approve the appointment.

DEPARTMENT RECOMMENDATION:

Mayor Hull recommends the reappointment of Lanny Busher to the Keep Rio Rancho Beautiful Committee.

ATTACHMENT: [L. Busher Resume](#)

Resume`

Lanny R. Busher



AA (Liberal Arts) Santa Ana College - 1976

BA (Public Service Management) University of Redlands – 1978

Teaching Certification – University of Phoenix – 2002

MA (Education) – University of Phoenix – 2003

Retired Naval Surface Warfare Officer – 1998 (LCDR - Ship Driver – Engineering, Combat Systems, Operations)

Hawaii Department of Education - Retired High School Teacher - 2014 (SPED, Social Studies-Waianae High School)

Hawaii Department of Education – Long Term Sub (Engineering-Waianae High School 2019 – 2022)

Waianae High School Grievance Rep – 2005 – 2014

Hawaii State Teachers Association – State Board Member 2011 – 2014

Hawaii State Teachers Association – Retired – 2014 – 2022 (Oahu Chapter Treasurer, Chair State Retired Issues Committee, Chair State Legislative Action Team)

National Education Association (NEA) – NEA Delegate Assembly 2011, 2012, 2013

Waianae High School PTSA – VP/President – 2001 – 2022

Waianae High School – School Community Council (SCC) – Member/Chair 2002 – 2022

Waianae High School – Head Coach Air Riflery Team (2002 – 2021)

Hawaii High School Athletic Association (HHSAA) – 2006 – 2022 State Committee Member - Air Riflery

Oahu Interscholastic Association (OIA) – 2004 – 2021 Stats Officer/Range Officer – Air Riflery

Waianae High School – Head Girls Track Team Coach – 2001 – 2012

Hawaii International Center (IHC) – International Foreign Exchange Student Host Family – 1989 – 2022 (Hosted over 300 Foreign Exchange Students/28 Full-Time High School Students)

Volunteer Service – Recognized by both President Bush and President Obama for over 10,000 hours of volunteer service.

KRRB Committee – 2023 – date

Active Member of Rio Rancho VFW and American Legion Posts

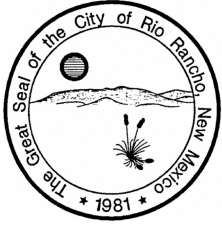

**CITY OF RIO RANCHO
COVER PAGE**

Legislation Item:

AGENDA DATE:

April 10, 2025

DEPARTMENT:

Administration

SUBJECT:

D20, Appointment of Jonathan Romero to the Parks and Recreation Commission

BACKGROUND AND ANALYSIS:

The commission works to ensure the efficient, economical and comprehensive planning of parks and recreation.

Romero resides in City Council District 1. If appointed, Romero will fill a vacancy (District 1) on the commission and serve a term that will expire on April 10, 2028.

IMPACT:

The appointment will fill a vacancy on the Parks and Recreation Commission.

ALTERNATIVES:

Approve the appointment.

Do not approve the appointment.

DEPARTMENT RECOMMENDATION:

Mayor Hull recommends the appointment of Jonathan Romero to the Parks and Recreation Commission.

ATTACHMENT: [J. Romero Resume](#)

JONATHAN ROMERO



Citizenship: U.S.

Veterans Preference: 10 Points

Military Service: 03/03-07/04, 05/09-06/10, 08/21-04/23

- Security Clearance: Secret
- Professional and personable in relating to clients and coworkers, over 12 years' experience in a financial/accounting setting.
- Exceptional listener with excellent verbal and written communication skills.
- Exceptional typing (80 WPM) & data entry skills (Excel intermediate/advance), Microsoft Power-Bi
- Dependable, responsible contributor committed to excellence and success.
- Efficient problem solver with excellent decision-making, organizational, and interpersonal skills; effectively communicator.
- Responsible for general ledger account reconciliations, month-end close, and preparation of financial statements in accordance with GAAP
- Preparation of bank reconciliations, general ledger analysis, financial audit preparation, internal controls & travel reimbursements
- Analytical thinker, relentless researcher and an experienced problem solver.
- Adaptable and able to work under pressure and remain productive in a fast-paced environment.

EDUCATION

<u>Master's Science in Accounting</u>	06/2020
Concentration: Finance Purdue University Global	
<u>Master's Degree in Business Administration</u>	02/2013
Concentration: Public Administration Keller Graduate School of Management	
<u>Bachelor's Degree in Business Administration</u>	02/2012
Concentration: Human Resource Management DeVry University	
<u>Associate's Degree in Medical Lab Technician</u>	05/2006
Concentration: Medical Lab Technician Apollo College	

WORK EXPERIENCE

Internal Auditor

Dates of Employment: 04/11/2021 to Present

Employer: US Forest Service Audit Assurance Directorate, Internal Quality Assurance Branch

Address: 3900 Masthead ST NE, Albuquerque, NM 87109

Supervision: 0

- Criteria Research to support adherence of OMB Circular A-123 - Management's Responsibility for Internal Control
- Execute and oversee the entire audit cycle, which includes risk management, control management of operations' efficacy, financial stability, and adherence to all relevant guidelines and legislation.
- Establish the scope of internal audits and create yearly plans to obtain outcomes.
- Acquire, examine, and assess accounting records, prior reports, information, flowcharts, etc.
- Sample testing, preparation of data analytics, testing methodologies, narrative creations, and universe obtainment.
- Create and provide reports that detail the audit's findings and procedure.
- Serve as an impartial, unbiased source of counsel to guarantee its legitimacy, legality, and accomplishment of its objectives.
- Find weaknesses and suggest cost-cutting and risk-aversion strategies.
- Keep lines of communication open with the process owners and stakeholders.
- Creation of NCANs and Corrective Action Plan (creation) as needed for non-compliance.
- Conduct follow up audits (validation testing) and follow up on milestones (CAP) follow ups, as needed.
- Participate in ongoing education about the federal's laws, guidelines, best practices, instruments, methods, and performance requirements (80 hours per bi-yearly).

Budget Analyst USAF

Dates of Employment: July 7, 2020 to April 10, 2021

Employer: United States Air Force

Address: 506 Commando way, CAFB, NM 88103

Supervision: 0

- Defense Travel System approver & certifier (Authorizations/Vouchers)
- GPC Monitoring (AO)
- Documentation Creation: Form 9, 4009 Loads for GPCs, MIPRs through DEAMS software (DOD)
- Performs budget formulation work involving preparation of detailed analyses or annual and/or multi-year budget estimates for assigned organization/programs into a consolidated budget request.
- Performs budget execution and administration work involving the monitoring of obligations incurred and the actual expenditures of a budget with different sources and types of funding.
- Uses automated budgetary systems(s) and computer-generated products in accomplishing budgeting assignments.
- Provides advice, assistance, and guidance on budgeting and related information.
- Conducts analyses, reviews, and special studies of financial management related information.
- Conducts budget-related training for functional contacts and/or program managers in assigned organizations.

Director of Accounting & Finance (Controller)

Dates of Employment: May 25, 2019 to March 2020 (Furlough due to COVID 19)

Employer: El Monte Sagrado Resort & Spa (Taos, NM)

Address: 317 Kit Carson Road Taos, NM 87571

Supervision: 4 Direct, 17 In-Direct

- Responsible for the property's overall accounting and financial management requirements.
- Responsible for representing the finance department during weekly meetings.
- Responsible for the local tax authority compliance of the hotel.
- Responsible for supporting and liaising with the General Manager meeting the strategic goals of the organization.
- Responsible for preparing and reviewing annual budgets, monthly forecasts, and operating results.
- Responsible for verifying all financial reports and ensuring that all transactions are accurate and in compliance with local government regulations.
- Responsible for liaising with the Corporate Controller or managing director of the organization.
- Able to prepare and submit management reports promptly and also ensure delivery deadlines.
- Able to effectively implement all accounting policies and procedures.
- Able to ensure a strong accounting and operational control environment to safeguard hotel assets.
- Petty Cash & Reconciliation requirement for Monthly Close-out.

Sr. Accountant

Dates of Employment: July 05, 2018 to May 24, 2019

Employer: Kit Carson Electric/Propane Cooperative

Address: 117 Cruz Alta Road Taos, NM 87571

Supervision: 3 Direct, 12 In-Direct

- Supervision of Payroll, Purchasing, Accounts Payable, and Accounts Receivable
- Preparation of Journal Entries, Fixed Journals, and Closing Entries for Preparation of RUS 7
- Preparation Financial Statements such as Balance Sheets, Statement of Cash Flows, RUS 7 & 219
- Reconcile Bank Statements, Capitalization of Special Equipment, Inventory, and Depreciation
- Enter Mileage & Fuel Usage into SEDC Accounting System
- Prepared documentation for purchases of bid proposals

Business Manager

Dates of Employment: December 03, 2016 to February 12, 2018

Employer: Peñasco Independent School District

Address: 13 School Road Peñasco, NM 87553

Supervision: 4 Direct, 6 In-Direct

- Prepare financial or regulatory reports required by laws, regulations, or boards of directors.
- Preparation of Quarterly Cash Report to NM Public Education Board
- Budget Preparation/Presentation to School Board of Education (Monthly Board Packet/Presentation)
- Prepare of Internal Controls and Audit Preparation
- Evaluate financial reporting systems, accounting or collection procedures, or investment activities and make recommendations for changes to procedures, operating systems, budgets, or other financial control functions.
- Interview and hire staff and oversee staff training.
- Develop and implement purchasing and contract management instructions, policies, and procedures.

Accountant II

Dates of Employment: April 19, 2013 to February 20, 2017 (Still Adjunct Faculty for ACC/EXCEL)

Employer: University of New Mexico-Taos

Address: 1157 County Road 110 Ranchos de Taos, NM 87557

Supervision: 4 Direct, 2 in-direct

- To evaluate accuracy, completeness, and compliance with reporting and procedural standards, prepare, review, or analyze accounting records, financial statements, or other financial reports.
- Create, manage, and evaluate budgets; create recurring reports that contrast planned and actual expenses.
- Prepare and handle purchase orders and requisitions for goods and equipment using the Banner System; support Director of Business Services in contract negotiations and policy formulation with suppliers.
- Maintained the University's Procurement Card, which has a \$25,000 maximum and a monthly reconciliation.
- Oversaw student and employee travel reimbursements to include, but not limited to: flight and itinerary planning, hotel reservations, and pre-diem receipts for meals and lodging.

MILITARY EXPERIENCE

Assistant Detachment Sergeant/E-7

Dates of Employment: March 28, 1998 to April 04, 2023 (Over 25 years of Experience)

- Two deployments to Iraq/Kuwait in support of Operation Iraq Freedom/New Dawn.
- Management of 43 troops to include annual evaluations & Battle Assembly preparation.
- During 2nd Deployment managed the Movement Control Team in Kalsu, Iraq which control the shipment of all freight through MNDC Central
- NCOIC of the Unit Prevention Program which includes drug testing of all soldiers assigned to 601st TTP.
- Management of Government Travel Credit with Credit Limit of \$6,000.

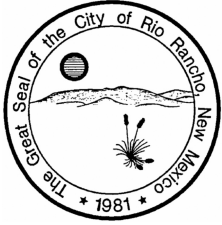

**CITY OF RIO RANCHO
COVER PAGE**

Legislation Item: D21

AGENDA DATE:

April 10, 2025

DEPARTMENT:

City Clerk

SUBJECT:

D21, Approval for Ragarm Development Company, LLC, DBA Betty's Revel Burger, (the "Applicant") Located at 300 Unser Blvd. SE, Rio Rancho, NM 87124 for Transfer of New Mexico Dispenser License DIS-001034 with On Premises Consumption Only to Include Patio Service

BACKGROUND AND ANALYSIS:

In accordance with 60-6B-4 NMSA, 1978 of the Liquor Control Act, the Director of Alcohol Beverage Control Division has granted this application conditional preliminary approval and has forwarded it to the Governing Body of Rio Rancho for public hearing and action.

IMPACT:

This application is for transfer of ownership for New Mexico Dispenser Liquor License No. DIS-001034 for on premises consumption only to include patio service located at 300 Unser Blvd. SE, Rio Rancho, NM 87124.

ALTERNATIVES:

If the Governing Body does not approve the issuance of the license, it shall notify the Alcohol Beverage Control Division setting forth the reasons for disapproval.

The Governing Body may disapprove the issuance of the license if:

1. The location is within an area where the sale of alcoholic beverages is prohibited by the laws of New Mexico;
2. The issuance is in violation of zoning (or other) ordinances of the City; or
3. The issuance is detrimental to the public health, safety or morals of the residents.

None of these conditions exist at the proposed site.

DEPARTMENT RECOMMENDATION:

Approve the application as presented by the NM Regulation and Licensing Department.

ATTACHMENT: [Betty's Revel Burger](#)

ATTACHMENT: [Notification of Withdrawn Application](#)

February 27, 2025

Certified Mail No.: 7021 2720 0001 2205 1167

City of Rio Rancho

City of Rio Rancho

Attn: Noel C. Davis, City Clerk

3200 Civic Center Circle NE

Rio Rancho, NM 87144

Lic. No. /Appl. No.: License No. **DIS-001034**
Name of Applicant: Ragarm Development Company, LLC
Doing Business As: Betty's Revel Burger
Proposed Location: 300 Unser Blvd., SE, Rio Rancho, New Mexico 87124

The Director of the Alcoholic Beverage Control Division (ABC) has reviewed the referenced Application and granted **Preliminary Approval**. It is being forwarded to you for Local Option District approval or disapproval of the Liquor License Application.

Notice of the Public Hearing required by the Liquor Control Act **shall be given by the governing body by publishing a notice** of the date, time, and place of the hearing **twice during the 30 days prior to the hearing** in a newspaper of general circulation within the territorial limits of the governing body. **The first notice must be published at least thirty (30) days before the hearing. Both publications must occur before a hearing can be conducted.** The notice shall include:

- (A) Name and address of the Applicant/Licensee;
- (B) The action proposed to be taken;
- (C) The location of the licensed premises.

In addition, if the Local Option District has a website, **the Notice shall also be published on the website.**

While the law states that “within forty-five (45) days after receipt of a Notice from the Alcoholic Beverage Control, the governing body shall hold a Public Hearing in the question of whether the department should approve the proposed issuance or transfer”, we recognize the potential for conflict between the requirement for publication of 30 day notice and the 45 day hearing requirement.

With that in mind, when a local governing body receives a liquor license application from ABC, that governing body has a couple of options:

- 1) Hold a hearing on the license application within the statutory time frame of forty-five (45) days, as required by the Liquor Control Act, and comply with all other statutory and regulatory procedures and notify ABC of your decision within thirty (30) days of the hearing;
- 2) Request from ABC an extension of time, past the forty-five (45) days, designating how much additional time will be needed to conduct the hearing in compliance with all statutory and



regulatory procedures. After the extension is granted and the hearing is held, notify ABC of your decision within thirty (30) days of the hearing;

ABC has no preference in the option you choose.

The governing body is required to send notice by certified mail to the Applicant of the date, time, and place of the Public Hearing. The governing body may designate a Hearing Officer to conduct the hearing. **A record shall be made** of the hearing.

THE APPLICANT IS SEEKING A TRANSFER OF OWNERSHIP OF DISPENSER LIQUOR LICENSE NO. DIS-001034 WITH ON PREMISES CONSUMPTION ONLY WITH PATIO SERVICE

Within thirty (30) days after the Public Hearing, the governing body shall notify ABC of their decision to approve or disapprove the issuance or transfer of the license by signing the enclosed original Page 1 of the Application. The original Page 1 of the Application must be returned together with the notices of publication. **If the Governing Body fails to either approve or disapprove the issuance or transfer of the license within thirty days after the Public Hearing, the Director may issue the license.**

If the Governing Body disapproves the issuance or transfer of the license, it shall notify ABC within thirty (30) days setting forth the reasons for the disapproval. A copy of the Minutes of the Public Hearing shall be submitted to ABC with the Notice of Disapproval (*Page 1 of the Application, noting disapproval*).

Respectfully,



Charmaine Martinez
Admin Law Judge | Hearing Officer
NM Regulation & Licensing Department
Alcoholic Beverage Control Division
Phone: (505) 795-4942 Fax: (505) 476-4595
Email: Charmaine.Martinez2@rld.nm.gov

Enclosures:

1. Page 1 (Business Information) (*must be signed and returned w/notices of publication*)
2. Page 2 (Premises Information)
3. Copy of Floor Plan





**Alcoholic Beverage Control Division
Dispenser Intake Application
Application Number: BLA-0000004663**



Business Information

Business Information

Business Name: Ragarm Development Company LLC	Type of Business: Alcohol
Business Structure: Limited Liability Company	FEIN: XX-XXX4386
State Tax ID Number: XX-XXXXX0-00-9	
Business Email: baseball@themacsports.com	Business Phone: 5055149143

Contact Person Information

Contact Person Name: New Mexico Liquor Licenses, LLC c/o Kyla Stoker	Contact Person Phone: 5059805614
Contact Person Email: kyla@newmexicoliquorlicense.com	

Business Mailing Address

Mailing Street: 801 Loma Colorado Blvd.	Mailing City: Rio Rancho
Mailing State: NM	Mailing Zip Code: 87124
Mailing Country: US	

Ownership Transfer Type

Specify the appropriate reason for filing this ownership transfer application?

- Applicant Business is buying/acquiring licenses from other business
- Applicant Business has a Change in Ownership

If there are new shareholders holding 10% or more ownership interest OR If stock is transferred among existing shareholders and there is a person/business who previously held less than 10% and is now holding 10% or more ownership interest, select "Applicant Business has a Change in Ownership."

Once you navigate to the next screen, you will not be able to change response of this question.

Local Option District Use Only: Local Governing Body of _____ City, County, Village

Public Hearing held on _____ 20_____. Please check one: Approved Disapproved

Signature of City/County Official: _____ Title: _____

Alcoholic Beverage Control Division Use Only: Approved Disapproved _____

Signed by Director: _____ Date: _____



Alcoholic Beverage Control Division
Dispenser Intake Application
Application Number: BLA-0000004663



Premises Information

License Information

Specify the type of transfer you are applying for?

- Transfer of Ownership and Location
- Transfer of Ownership

License Number: DIS-001034
License Expiration Date: 6/30/25
Current DBA Name: THE LOCAL BREWHOUSE
Dispenser Type: Inter-Local Dispenser

License Type: Dispenser
Current License Owner: KIWI ENTERPRISES, LLC
Current Lessee:

Current Premises Address

Physical Street: 300 UNSER BLVD. SE
Physical State: NM
Physical County: Sandoval

Physical City: Rio Rancho
Physical Zip Code: 87124
Local Option District: Rio Rancho

Proposed DBA Name

Do you want to change the license DBA Name? Yes
Requested DBA Name: Betty's Revel Burger

Ownership

The land and building which is proposed to be the licensed premises is: Other

The following information is required to ensure the issuance of a license to this location will not result in the violation of a county or municipal ordinance.

Other (provide details): Contract Purchaser under Purchase Agreement dated 12/9/2024

Specify Owner(s) of the land and building: Kiwi Investments LLC

Specify Date and Terms of Lease/Operating Agreement: Purchase Agreement date 12/9/2024

Questions

Has the applicant business ever had a liquor license denied, suspended, revoked, surrendered, or had any other form of discipline or disciplinary action by a licensing agency in another state or jurisdiction?	No
Has the structure and/or ownership disclosure for the applicant business changed since last reported to the department?	No
Does the applicant business own any (direct/indirect) interest in a liquor license?	No



Alcoholic Beverage Control Division
Dispenser Intake Application
Application Number: BLA-0000004663



Payment

Fee Name	Fee Amount
Transfer of Loc/Own	200.00
Resident Agent Fee	50.00
Total Fee Amount:	250.00

Attestation/Oath

Under penalty of perjury, I hereby depose and state that I am the person identified in this application and the information given by me is true and complete to the best of my knowledge and belief. I understand that any information contained in this application may be investigated and any false or dishonest answer to any question in this application may be grounds for denial or revocation of my license.

Attestation Signature: Ragarm Development Company LLC

Date: 12/29/2024

UNSER BLVD.

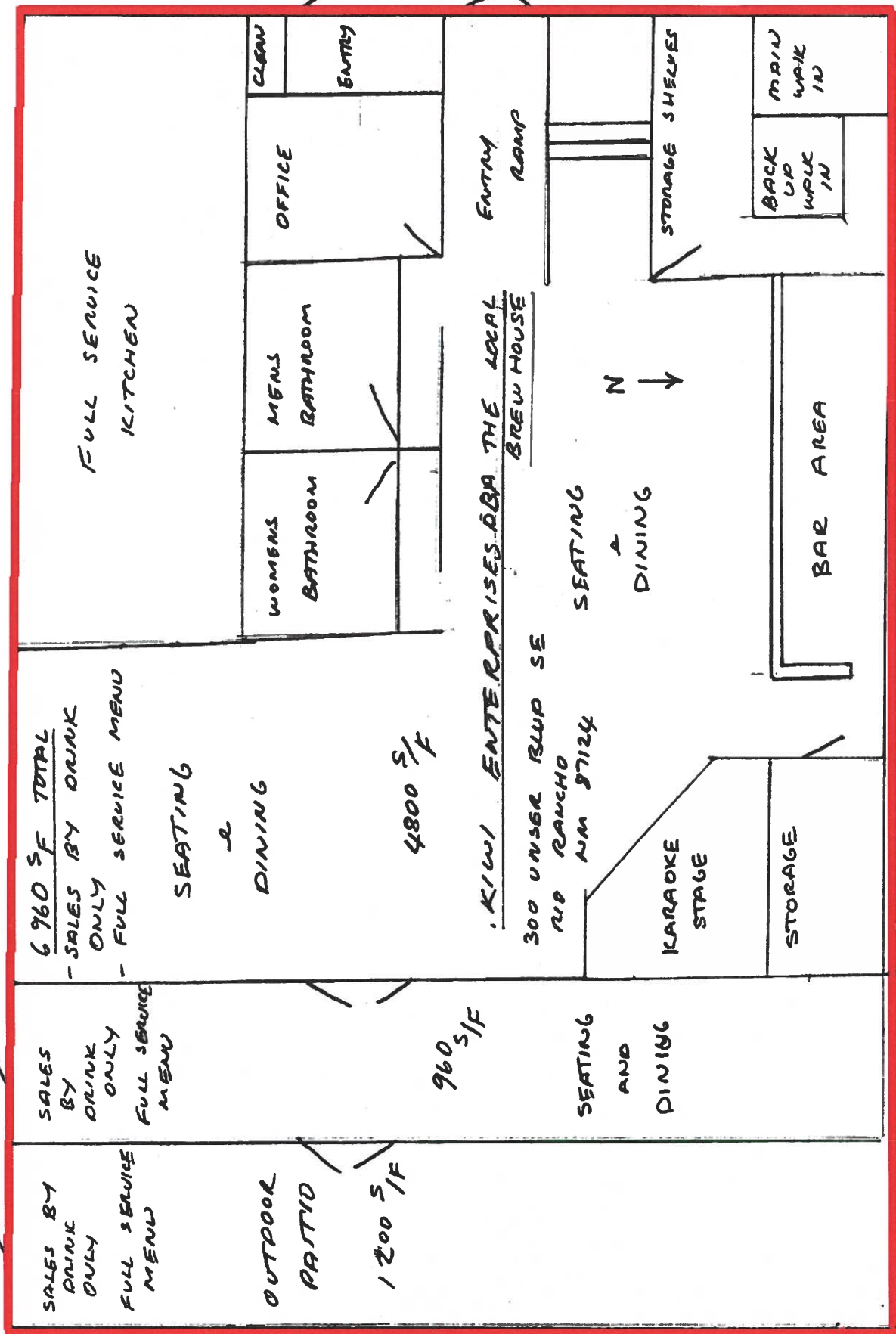

Alcoholic Beverage Control Division
 Inter-Local Dispenser Liquor License #2641
 Owner: ~~Kiwi Enterprises, LLC~~
 DBA: ~~The Local Brew House~~
 Location: 300 Unser Blvd SE, Rio Rancho, NM 87124
 Total Square Footage: 6,960

FLOOR PLAN APPROVAL
 By Desiree Givredo
 Date May 17, 2023

From: [Koroneos-Martinez, Charmaine, RLD](#)
To: [YOLANDA LUCERO](#)
Subject: RE: [EXTERNAL] FW: Notice of Liquor License Hearing - Ragarm Dev Company LLC
Date: Monday, March 31, 2025 9:35:51 AM
Attachments: [image004.png](#)
[image005.png](#)
[image006.png](#)
[image007.png](#)

Caution! This message was sent from outside your organization.

[Report](#)

Hello,

Yes the Application has been withdrawn. My apologies that I didn't confirm with you.



Charmaine Martinez | Admin. Law Judge |Hearing Officer
Alcoholic Beverage Control Division
2550 Cerrillos Road | Santa Fe, NM 87505
P.O. Box 25101 | Santa Fe, NM 87504-5101
charmaine.martinez2@rld.nm.gov | <https://www.rld.nm.gov/abc/>
(505) 795-4942

SERVICE | DEDICATION | INTEGRITY

From: YOLANDA LUCERO <ylucero@rrnm.gov>
Sent: Monday, March 31, 2025 9:25 AM
To: Koroneos-Martinez, Charmaine, RLD <Charmaine.Martinez2@rld.nm.gov>
Cc: Noel Davis <ndavis@rrnm.gov>
Subject: [EXTERNAL] FW: Notice of Liquor License Hearing - Ragarm Dev Company LLC

CAUTION: This email originated outside of our organization. Exercise caution prior to clicking on links or opening attachments.

Good morning Charmaine,

We received notice that Ragarm Development Company, LLC dba Betty's Revel Burger has withdrawn their liquor license application from ABC. Can you please confirm, as we have already had the legal notice published and notice of hearing scheduled for 4/10/25.

Thank you,

Yolanda Lucero
Deputy City Clerk

City of Rio Rancho | Office of the City Clerk

O: 505.896-8709

RRNM.gov |



From: Kyla Stoker <kyla@newmexicoliquorlicense.com>
Sent: Saturday, March 29, 2025 7:11 PM
To: YOLANDA LUCERO <ylucero@rrnm.gov>
Cc: baseball@themacsports.com
Subject: Re: Notice of Liquor License Hearing - Ragarm Dev Company LLC

Good evening Yolanda,

The applicant has withdrawn their application with the state ABC.

I will allow the applicant to confirm and you are welcome to check in with Charmaine Martinez at ABC regarding the same.

Thank you,

Kyla Stoker
New Mexico Liquor Licenses, LLC
cell: [\(505\) 980-5614](tel:5059805614)
fax: [\(505\) 212-0227](tel:5052120227)
www.NewMexicoLiquorLicense.com

2539 Wyoming Blvd NE
Albuquerque, NM 87112

CONFIDENTIALITY NOTICE - This e-mail transmission, and any documents, files or previous e-mail messages attached to it may contain information that is confidential or legally privileged. If you are not the intended recipient, or a person responsible for delivering it to the intended recipient, you are hereby notified that you must not read this transmission and that any disclosure, copying, printing, distribution, or use of any of the information contained in or attached to this transmission is STRICTLY PROHIBITED. If you have received this transmission in error, please immediately notify the sender by telephone or return e-mail and delete the original transmission and its attachments without reading or saving in any manner. If you are receiving a Letter of Intent, Exclusive Listing Agreement, Commission Agreement, Lease or Purchase Agreement, these documents have been prepared for the approval of your attorney. New Mexico Liquor Licenses, LLC makes no representation on the legal sufficiency or tax consequences of these documents or the transaction(s) to which they pertain. Please consult your attorney and tax advisor.

On Mar 4, 2025, at 9:58 AM, YOLANDA LUCERO <ylucero@rrnm.gov> wrote:

Good morning,

Please see the attached notice of hearing for liquor license DIS-001034.

Let me know if you have any questions.

Thank you,

Yolanda Lucero

Deputy City Clerk

City of Rio Rancho | Office of the City Clerk

O: 505.896-8709

[<image001.png>](#)

RRNM.gov | [<image002.png>](#)

[<image003.png>](#)

<Betty's Revel Burger.pdf>

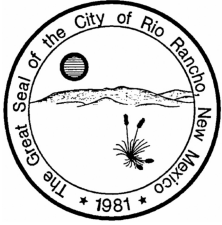

**CITY OF RIO RANCHO
COVER PAGE**

Legislation Item: D22

AGENDA DATE:

April 10, 2025

DEPARTMENT:

Development Services

SUBJECT:

D22, Site Plan Approval for an Extended Stay Hotel at the Property Legally Described as High Resort Market Place, Block A, Tract B1

BACKGROUND AND ANALYSIS:

The subject property is legally described as High Resort Market Place, Block A, Tract B1 and addressed as 360 Ridgeway Drive SE. The property consists of approximately 1.90 acres and is zoned SU: Special Use for C-1 Regional Shopping Center per Ordinance 86-002.

The property received a Zoning Interpretation authorizing "hotels and motels" a legitimate and permissive commercial use in this zone by the Planning and Zoning Board on June 13, 2023, per Resolution No. PZB-14, Enactment No. 23-01.

CONFORMANCE WITH THE CITY ZONING ORDINANCE:

The Rio Rancho Code of Ordinances (R.O. 2003) §154.43 (3) requires "All SU zoned property must have a Site Plan approved by the Governing Body. The Site Plan may accompany the application for a change in zoning designation or may be submitted for approval at a later date.

Approval of the Site Plan must be obtained prior to any development of the property." Pursuant to the criteria provided by R.O. 2003 § 154.43 (3)(a) through (3)(j), the Site Plan, at a minimum, shall contain the following:

- a. Scale and north arrow; criteria is satisfied.
- b. Lot boundaries and easements; A 5 ft Public Utility Easement surrounds the property to the west and north. There is also a 30 ft Access easement to the east; criteria is satisfied.
- c. Existing and proposed utilities; criteria is satisfied.
- d. Existing and proposed rights-of-way; criteria is satisfied.
- e. Proposed structure with uses, dimension, and setbacks; The building height at the highest point is 35 feet, in compliance with the C-1 height maximum of 50 ft per Chapter 154.51. Building setbacks are over 10 ft. from the front and corner side, also in compliance with this section of the Ordinance; criteria is satisfied.
- f. Proposed ingress, egress, parking, and circulation; One access point to the site will be provided to the southwest end of the property, off of Ridgeway Drive SE. Shared access needs to be accessible to the east of the site and this has been added as a condition of approval. The hotels and motels use of the property requires 1 space for each unit; 1 space for each 2 employees which equates to 88 required parking spaces for a building with 88 rooms; the Site Plan proposes 89 spaces and meets the required ADA parking spaces (4). Depending on the number of employees, additional parking may be required and this is listed as a condition of approval; criteria is satisfied.
- g. Landscaping and landscape buffers; Per the landscape plan, 11,327 square feet of landscaping

will be provided. The required landscape area is a minimum of 10% of the lot, which would be 8,276 square feet; criteria is satisfied.

h. Elevations; Elevations have been provided meeting the Nonresidential Design Criteria under Section 154.61 of City Code; criteria is satisfied.

i. Adjacent property characteristics; The property to the east, south and north are zoned SU: Special Use under the same Ordinance as the subject property. The properties to the west are zoned R-1: Single-Family Residential; criteria is satisfied.

j. Preliminary drainage plan; criteria is satisfied.

NOTIFICATIONS:

Adjacent property owners were notified of this hearing by mail. A notice sign was posted on the property on April 3, 2025. A legal notice was published in the April 10, 2025 edition of the Albuquerque Journal for the Governing Body meeting. All legal notification requirements for this project have been met.

INTERDEPARTMENTAL/INTERAGENCY REVIEW:

Reviewing Agency	Received Application for Review	Comments
DSD Planning and Zoning	X	Comments provided in this document
DSD Engineering	X	<ul style="list-style-type: none"> • Shared access needs to be accessible. • Check water quality and quantity for ponds, appears to not be captured. • Dumpster cannot be over waterline.
Rio Rancho Public Schools	X	No comments provided
Fire and Rescue	X	Comments attached
Police Department	X	No comments provided
SSCAFCA	X	Comments attached
MRCOG	X	No comments provided
Parks, Recreation and Community Services	X	Comments attached

IMPACT:

The Development Services Department recommends the Governing Body approve the applicant's request for a Site Plan approval with the following findings of fact and conditions of approval.

GENERAL FINDINGS:

1. R.O. 2003 Section 154.43 (3) requires Site Plan approval by the Governing Body;
2. The applicant has the authority to apply for Site Plan approval;
3. The applicant and adjacent property owners received due process as proper notice and a full opportunity to present views were given.

SPECIFIC FINDINGS AND CONDITIONS OF APPROVAL:

1. The subject property is zoned SU: Special Use District by Ordinance No. 86-002. The SU: Special Use zoning designation requires that a Site Plan be reviewed and approved by the Governing Body.

2. The Site Plan conforms to the Rio Rancho Code of Ordinances (R.O. 2003) Section 154.43.
3. Development of the site will conform to all City ordinances, standards, and specifications.
4. The review and subsequent building permit applications will ensure conformance to the approved Site Plan and City ordinances, standards, and specifications.
5. The signage of the development shall adhere to the Sign Code Ordinance.
6. The applicant shall address all of the Site Plan reviewer comments including but not limited to: access may be subject to change based on further review of the access spacing.
7. Parking shall comply with Rio Rancho Code of Ordinances (R.O. 2003) Section 154.76 including parking for employees.
8. The applicant shall obtain a water, wastewater approval letter.
9. The Director of the Development Services Department may approve minor changes to this Site Plan if the changes are consistent with the use and other written requirements and/or conditions of approval, if the buildings are the same general configuration, if the total square footage is not greater than 10% of the approved plan, the site circulation is similar in its effect on adjacent property or streets, and the approving official finds that neither the City nor any person will be substantially aggrieved by the altered Site Plan.
10. This approval is valid for a period of three years from date of approval, in which time a building permit for the proposed structures must be applied for and issued, remain active, and the authorized construction shall be started and diligently pursued to completion without cessation of 30 days.

ALTERNATIVES:

1. The Governing Body may approve the site plan.
2. The Governing Body may deny the site plan.
3. The Governing Body may modify the site plan request and approve such modifications.
4. The Governing Body may continue the public hearing to request additional information or to consider testimony provided at the public hearing.

DEPARTMENT RECOMMENDATION:

The Development Services Department recommends the Governing Body approve the applicant's request for a Site Plan approval with findings of fact and conditions of approval.

ATTACHMENT: [Application](#)

ATTACHMENT: [Authorization](#)

ATTACHMENT: [Zoning, Location](#)

ATTACHMENT: [Staff Comments](#)

ATTACHMENT: [Site Plan, Utilities](#)

ATTACHMENT: [Landscape Plan](#)

ATTACHMENT: [Elevations](#)

ATTACHMENT: [Reproduction of Notices](#)

ATTACHMENT: [PZB- Zoning Interpretation, Ordinance 86-002](#)

PLANNING & ZONING LAND USE APPLICATION

Please check appropriate box

Administrative Permit	Plan	Subdivision	Zoning
<input type="checkbox"/> Community Residential Care Facility	<input type="checkbox"/> Comprehensive Plan Amendment	<input type="checkbox"/> Final Plat	<input type="checkbox"/> Annexation
<input type="checkbox"/> Development Review Committee (DRC)	<input type="checkbox"/> Corridor Plan Amendment	<input type="checkbox"/> Preliminary Plat	<input type="checkbox"/> Appeal
<input type="checkbox"/> Home Occupation	<input type="checkbox"/> Master Plan	<input type="checkbox"/> Summary Plat	<input type="checkbox"/> Conditional Use Permit
<input type="checkbox"/> Model Home / Sales Office	<input type="checkbox"/> Master Plan Amendment	<input type="checkbox"/> Vacation of Plat/Street	<input type="checkbox"/> Master Sign Plan
<input type="checkbox"/> Residential Child Care Facility 6 or <	<input type="checkbox"/> Specific Area Plan Amendment	<input type="checkbox"/> Street Name Change	<input checked="" type="checkbox"/> Site Plan
<input type="checkbox"/> Sign Permit	<input type="checkbox"/> Text Amendment	<input type="checkbox"/> Subdivision Interpretation	<input type="checkbox"/> Special Exception
<input type="checkbox"/> Other		<input type="checkbox"/> Subdivision Variance	<input type="checkbox"/> Variance
			<input type="checkbox"/> Zone Map Amendment
			<input type="checkbox"/> Zoning Certification
			<input type="checkbox"/> Zoning Interpretation

Please Print In Ink Only or Type

Application must be complete. Please attach the appropriate checklist for the action you are requesting, if applicable.

APPLICANT/AGENT INFORMATION

Applicant Name: Yogash Kumar c/o Nick Eveleigh (rne@hmsgallup.com) 339-6201		Phone: (505) 879-7613
Address: 8300 Washington St, NE		E-Mail: yogash@hmsgallup.com
City: Albuquerque	State: NM	Zip: 87113
Proprietary Interest: Owner	List Owners:	
Deed or Ownership Verification Provided: (Initials)		Letter of Authorization Provided: (Initials)

Agent Name: Clark Consulting Engineers		Phone: (505) 281-2444
Address: 19 Ryan Rd		E-Mail: CCEalbq@aol.com
City: Edgewood	State: NM	ZIP Code: 87015

DESCRIPTION OF REQUEST: (PLEASE ADD ADDITIONAL SHEET(S) IF NECESSARY)

Approval of Site Plan, 88-Room extended stay apartments located @ 360 Ridgeway Dr, SE

SITE INFORMATION: (PLEASE PROVIDE ACCURATE LEGAL DESCRIPTION)

Subdivision/Unit : High Resort Market Place	Block(s): A	Lot(s): Tr. B-1
Existing Zoning: SU / NR	Proposed Zoning: Same, SU / NR	
No. of existing lots: 1	No. of proposed lots: 1	Total area of site (acres) 1.89 Ac.

ACKNOWLEDGEMENT

I hereby acknowledge that I have read this entire application and affirm that all information provided is correct. I agree to comply with the requirements of the City of Rio Rancho as outlined in all applicable laws, ordinances and regulations.

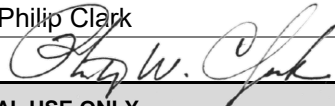
Print Name: Philip Clark	Applicant:	Agent: yes
Signature: 		Date: 1/3/25 / 1/29/25

FOR OFFICIAL USE ONLY

H.T.E. PROJECT #	FEE	RECEIPT #
25-160-00002		

APPLICATION ACCEPTED BY: Michelle Costilla DATE: 2/25/25

DURANO ENTERPRISES LTD
P.O. BOX 90625
ALBUQUERQUE NM 87199

April 20, 2023

RE: OWNER AUTHORIZATION

To Whom It May Concern:

We are authorizing R-Nicholas Eveleigh, Hospitality Management Services and Derrick Archuleta, ARCH+PLAN Land Use Consultants to represent us with all matters pertaining to a Zone Map Amendment (Special Use zoning designation) for a proposed hotel. The legal description is Tract B1, Block A, High Resort Market Place (UPC # 1-014-069-055-171 / R042074), located at 360 Ridgeway Drive SE, between Crestview Drive and Ridge Rock Road north of Pat D'Arco Highway within the City of City of Rio Rancho.

The authorization will include, but not limited to:

- Preparation of materials for the Development Review Committee, Planning and Zoning Board and the Governing Body
- Project management
- Project representation
- Execution of all documents required to be submitted to the City of Rio Rancho and any other requesting agency.

If you have any questions, please contact me.



Manager of Durano Asset Mgt. as General Partner of Durano Enterprises Ltd.

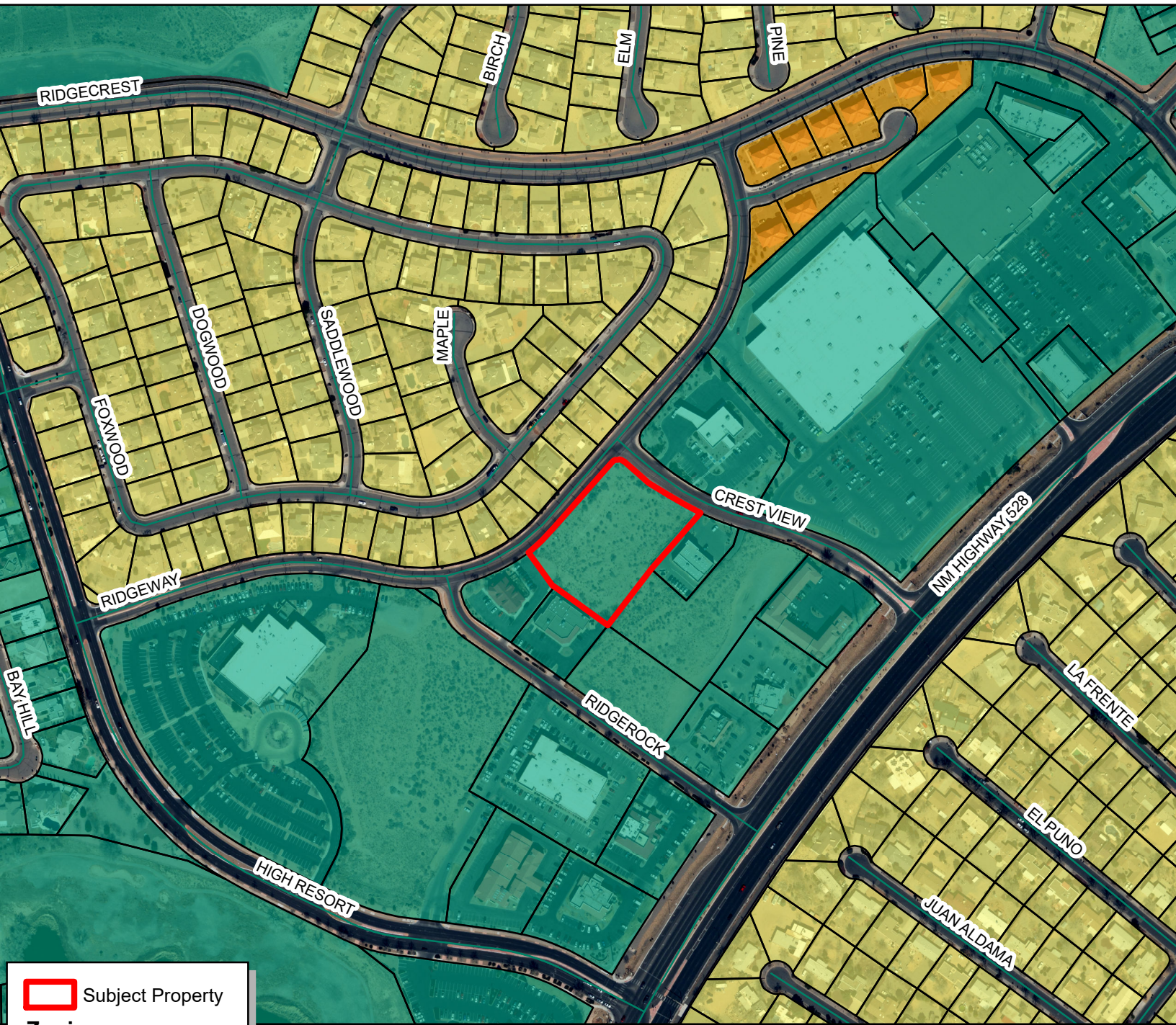

Authorized Representative
Durano Enterprises Ltd

360 RIDGEWAY DR SE



 Subject Property

Zoning

-  R-1
-  R-3
-  SU

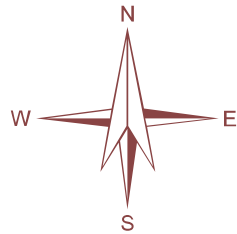

DISCLAIMER: All information in this map is provided "as is" without warranty or any representation of accuracy, timeliness or completeness. This map is not a survey and should be used for graphical purposes only.

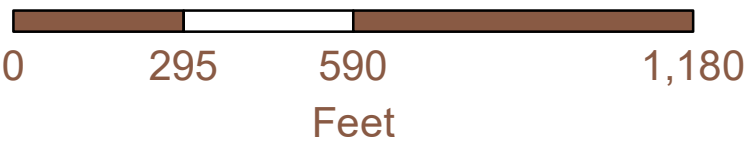



City of Rio Rancho
Development Services
3200 Civic Center Circle NE - Ste 130
Rio Rancho, NM 87144
(505) 891-5005 Fax: (505) 896-8994

March 21, 2025

TO: Clark Consulting Engineers
19 Ryan Rd
Edgewood, NM 87015

RE: Site Plan (25-160-00002)

The following are the comments and feedback received in regards to the site plan application.

Fire and Rescue:

1. Builder has already reached out to FMO for site requirements. They have supplied a Fire 1 with approval from FMO. Once the entire plan set comes in we will add it to the created permit number.

Parks and Recreation:

1. The landscape plan appears correct (appropriate species, square footage, distribution). Irrigation backflow preventer will need to be registered and tested per ordinance 54.0.
2. The handicap parking sign detail shown on the site and utility plan sheet does not comply with the state statute and handicap aisles do not have an appropriate detail. Verify that handicap parking spaces are designed and constructed as ADA compliant – with no slope (run, cross slope, etc.) within the handicap parking space and aisle – greater than 2.083% in any given direction. For the HC accessible route to the building, the route shall also have a cross slope no greater than 2.083% and the run (direction of travel between parking space and building) has a slope no greater than 5%. For the accessible aisle adjacent to the handicap parking space, follow the NM Statute which requires that the striped area meet the requirements set out in NMSA 66-1- 4.1.B] and that 1' high letters that are at least 2" wide stating NO PARKING are stenciled in the aisle. Please reference the Parking Lot Checklist provided by the NM Governor's Commission on Disability for parking space and sign requirements found at: <http://gcd.state.nm.us/wp-content/uploads/2018/11/2015-NM-Accessible-Parking-FINAL2.pdf>. Page 7 of this checklist also clearly shows the type and color/s of handicap parking signs (New Mexico specific) to be installed, as well as the language required per State Statute.

SSCAFCA:

1. The proposed ponds only have the capacity for the water quality volume. Per City of Rio Rancho DPM, the increased flow due to development must be retained on-site and discharged at the historic rate. How does the design address this requirement?

If you have any additional questions or concerns please feel free to contact me.

Respectfully,

A handwritten signature in black ink that reads "Michelle Costilla". The signature is written in a cursive style with a large initial "M" and a long, sweeping underline.

Michelle Costilla
Municipal Planner II
Development Services Department
City of Rio Rancho
(505) 896-8362 mcostilla@rrnm.gov

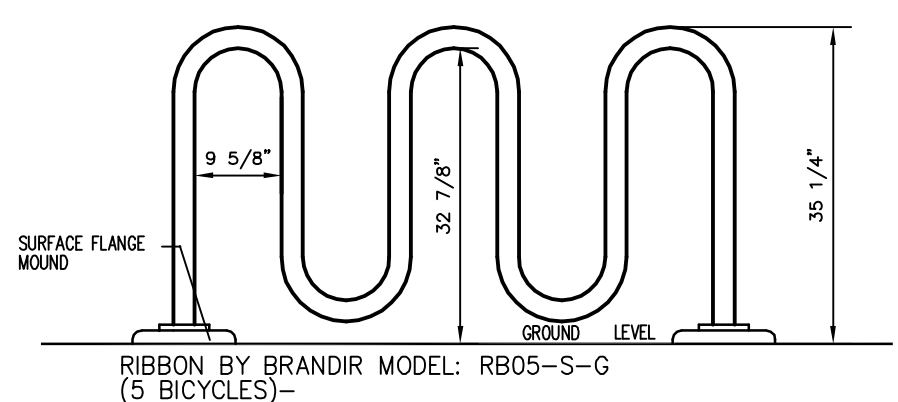

BIKE RAIL

HANDICAP PARKING SIGNS

NTS

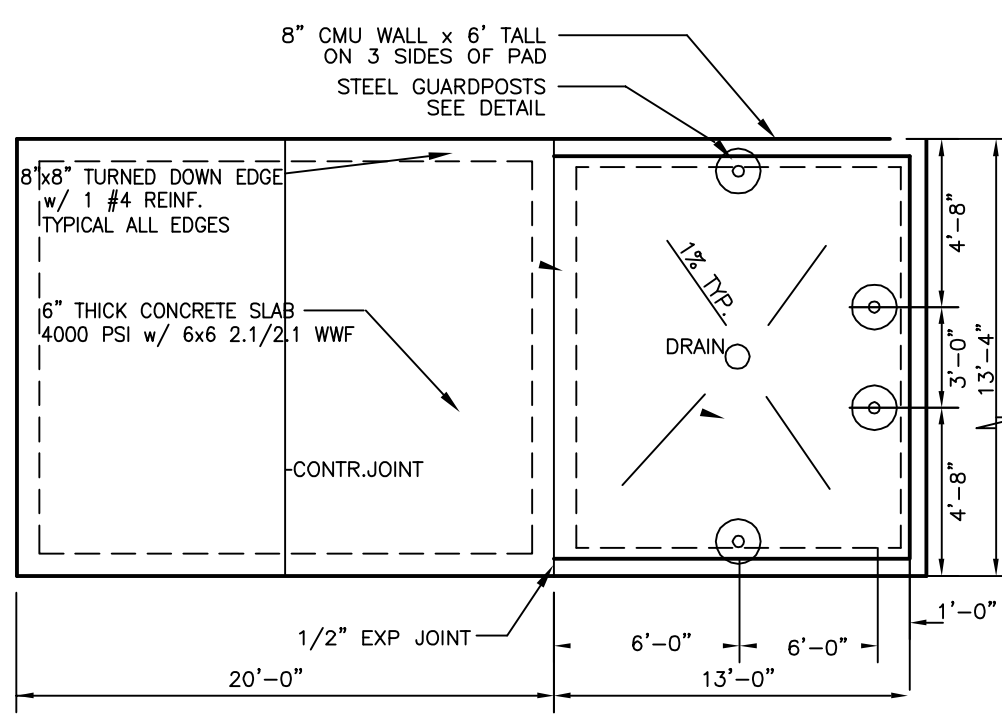
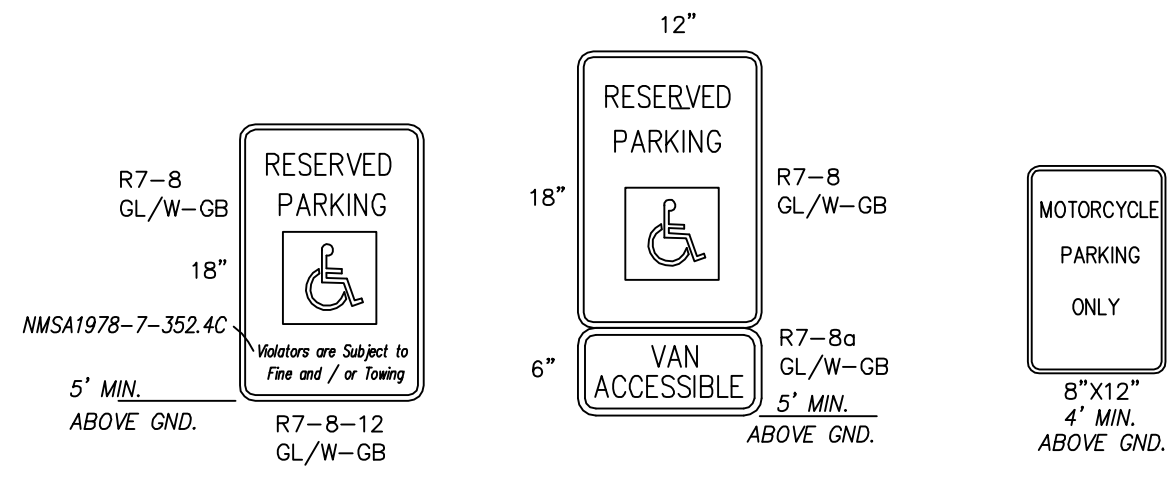

REFUSE ENCLOSURE PLAN

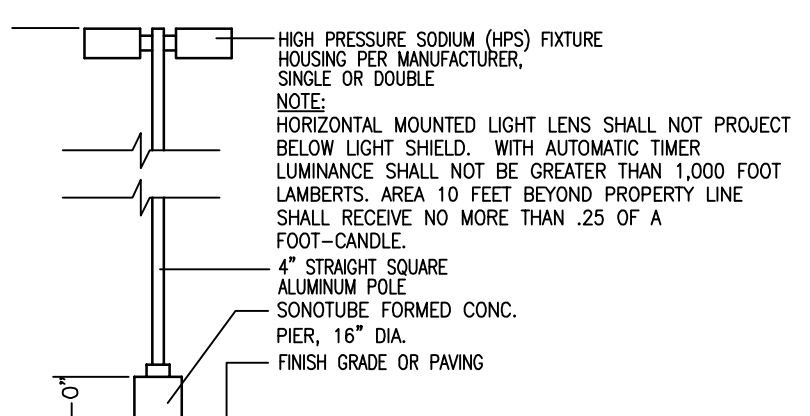

POLE LIGHT FIXTURE DETAIL

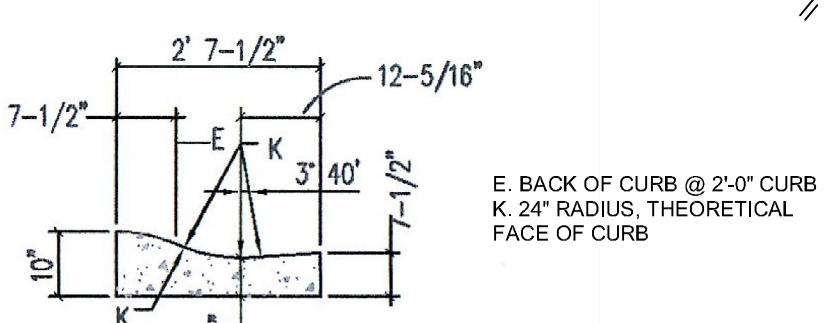

MOUNTABLE-ROLL CURB / GUTTER

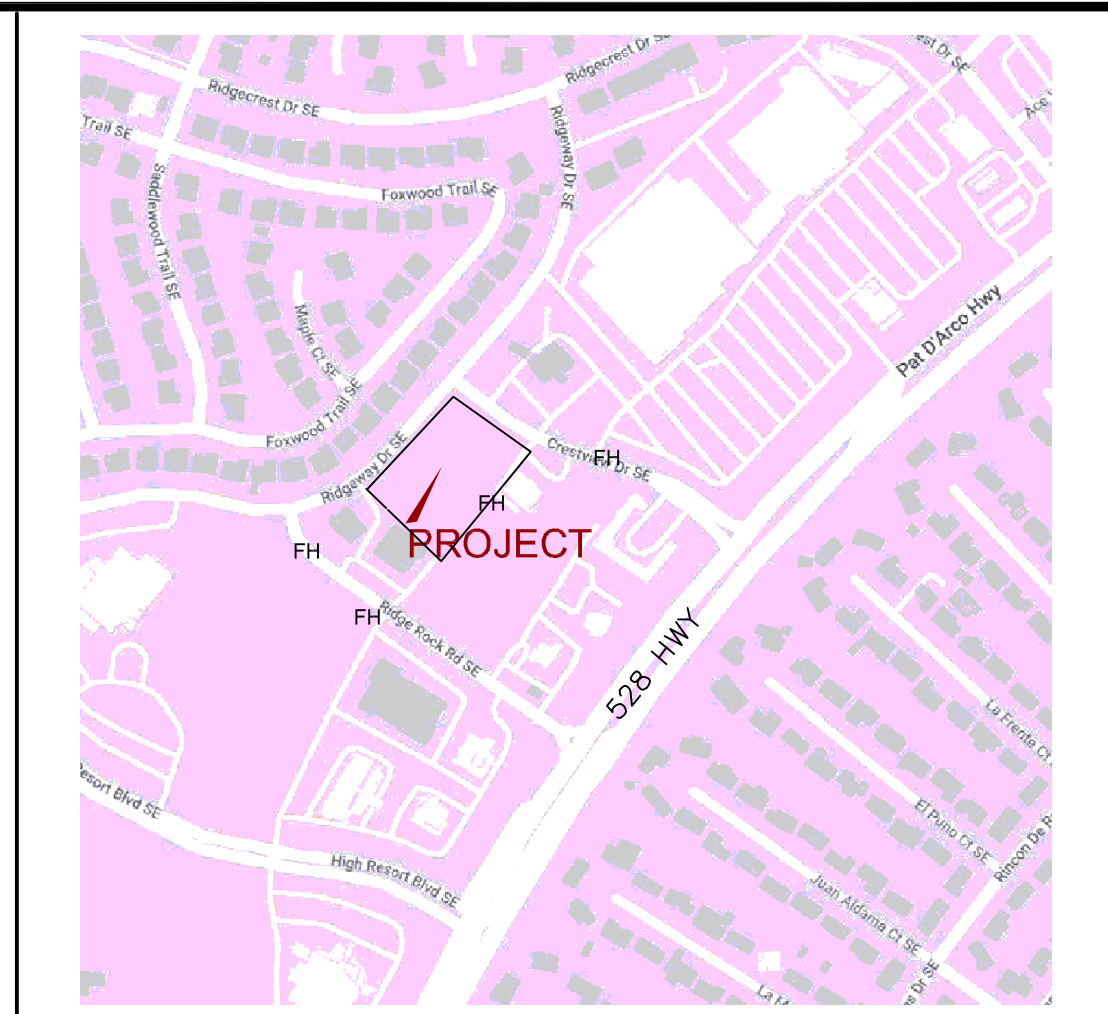
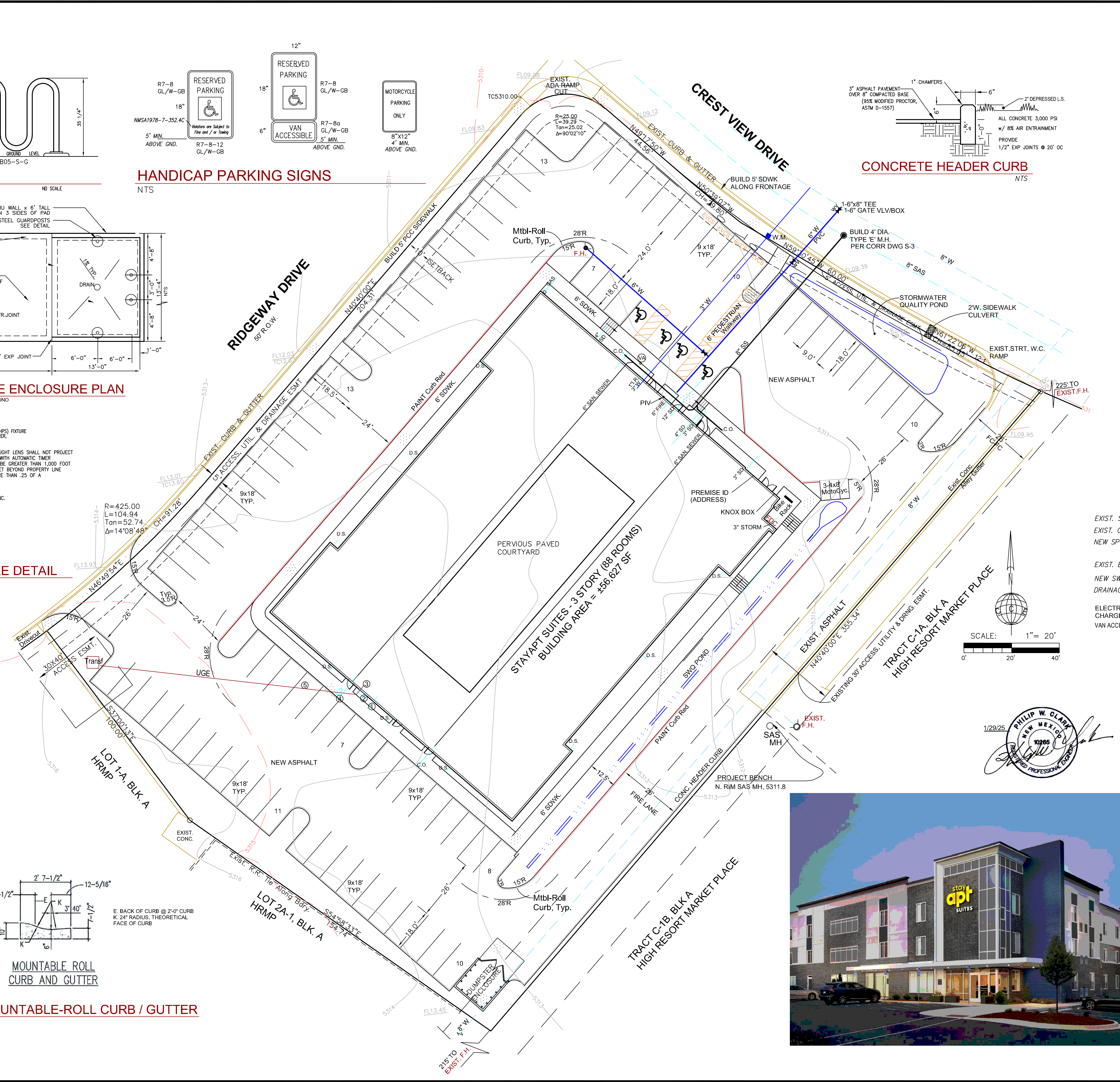

VICINITY MAP
NOTES

1. CONSTRUCT ALL IMPROVEMENTS WITHIN THE CITY RIGHT-OF-WAY IN ACCORDANCE WITH THE "NMSH&T DEPT. STANDARD SPECIFICATIONS FOR ROAD AND BRIDGE CONSTRUCTION, AND CORR STANDARD SPECS.
2. DIMENSIONS ARE MEASURED TO FACE OF CURB, UNLESS NOTED OTHERWISE. CURB RADIUS' ARE 4.5', UNLESS NOTED OTHERWISE.

KEYED

- 1 PROVIDE (3) 3" CONDUITS TO THE PROPERTY LINE FOR INCOMING TELEPHONE, CABLE TV, AND ISP UTILITY
- 2 CT CABINET (IF REQ'D) AND METER COORDINATE WITH UTILITY
- 3 TO MDP
- 4 SECONDARY ELECTRICAL SERVICE ENTRANCE CONDUCTORS
- 5 UNDERGROUND ELECTRIC (UGE) TO TRANSFORMER LOCATION COORDINATE ELECT. PLAN

LEGEND

EXIST. SPOT ELEVATION	+24.0	NEW CONCRETE	
EXIST. CONTOUR	10	EDGE OF GRAVEL	EG
NEW SPOT ELEVATION	Add 5300 For MSL +09.0	EXISTING POWER POLE	PP
EXIST. EDGE OF ROAD		RIPRAP ROCK EROSION PROTECTION, 8" BURY	D50=4"
NEW SWALE		EXIST. NATURAL GROUND	GR
DRAINAGE DIRECTION		FLOWLINE	FL
ELECTRIC VEHICLE CHARGING STA.	EVCS	SANITARY SEWER	SS
VAN ACCESSIBLE SIGN		STORM DRAIN	SD
		NEW WATER	W
		NEW FIRE HYDRANT	F.H.

PROJECT DATA

REFERENCE: DRC (23-250-00021)
 FIRE CODE - INTERNATIONAL FIRE CODE 2021; GRADE: LESS THAN 10% DRIVE SURFACE: SUPPORT 75,000 LBS.
 BUILDING SIZE: 56,500 GSF, 88 ROOMS
 CONSTRUCTION TYPE: V-A, SPRINKLERED
 FIRE FLOW REQUIRED, REF: TABLE B105.1(2)
 4250 GPM; 2125 GPM (SPRINKLERED)
 3 FIRE HYDRANTS REQUIRED / 3 EXISTING
 SITE SIZE: 1.89 ACRES
 CURRENT AND PROPOSED ZONE: SUNR, SPECIAL USE NON-RESIDENTIAL PER HIGH RESORT MARKET PLACE MASTERPLAN
 UNDERLYING: C-1, SHOPPING CENTER
 SETBACKS: 0' SIDE AND REAR; 10' CORNER AND FRONT
 PARKING SPACES PROVIDED: 89
 4- ACCESSIBLE SPACES, 1 VAN ACCESSIBLE
 PARKING SPACES REQ.: 88

LEGAL DESCRIPTION
 TRACT B-1, BLOCK A, HIGH RESORT MARKET PLACE RIO RANCHO ESTATES, NEW MEXICO
PROJECT BENCHMARK
 NORTH MANHOLE RIM, IN ACCESS EASEMENT ON E. BDRY NAVD 88., SEE PLAN. MSL ELEV. 5312z
TOPOGRAPHIC SURVEY
 COMPILED BY CCE FROM ORTHO-PHOTOGRAMMETRY AND CST, INC. DESIGN SURVEY, DATED APRIL/2024.

REFERENCE: DRC (23-250-00021)

		Edgewood, New Mexico 87015 Tele: (505) 281-2444	
DATE	REVISION	TRACT B-1, BLK A, HIGH RESORT MARKET PLACE RIO RANCHO ESTATES, NEW MEXICO	
		StayApt SUITES 360 RIDGEWAY DRIVE SE	
		SITE PLAN & UTILITIES	
DESIGNED BY: PWC	DRAWN BY: CCE	JOB #: StayApt	1 OF 1
CHECKED BY: PWC	DATE: APR24	FILE #: SITE PLAN	

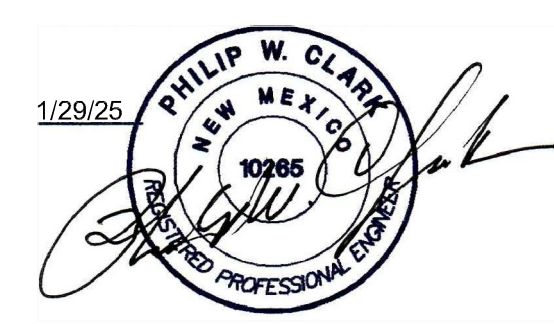

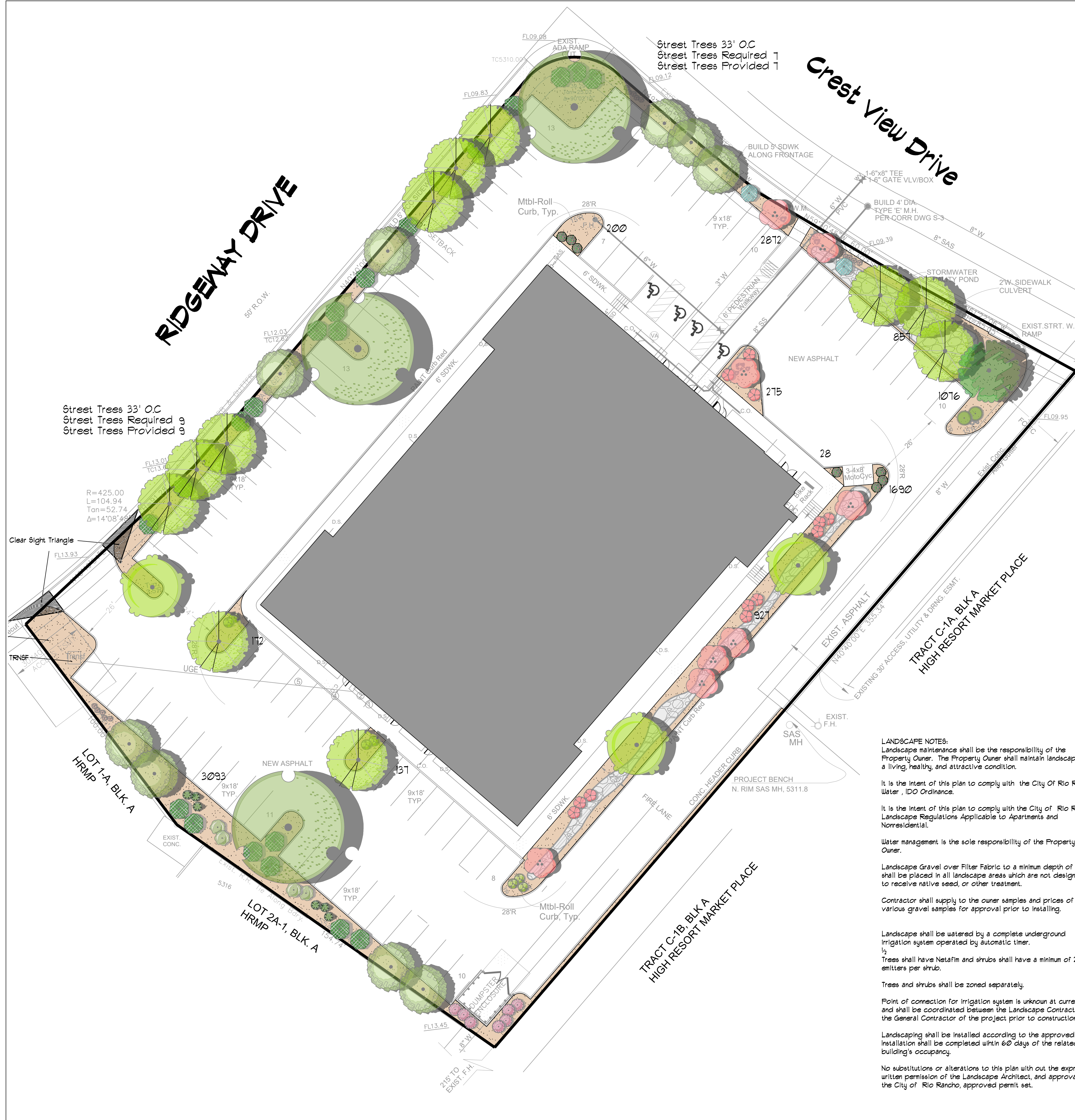

PLANT SCHEDULE

SYMBOL	QTY	SIZE	COMMON / BOTANICAL NAME	WATER USE
--------	-----	------	-------------------------	-----------

TREES				
	1	4-6'	Austrian Pine <i>Pinus nigra</i>	Medium
	6	4-6'	Blue Arrow Juniper <i>Juniperus scopulorum</i> Blue Arrow	Very low
	3	2' Cal.	Chinese Pistache <i>Pistacia chinensis</i>	Low - Medium
	11	2' Cal.	Gambel Oak <i>Quercus gambelii</i>	Low - Medium
	9	2' Cal.	Paul's Scarlet English Hawthorn <i>Crataegus laevigata</i> Paul's Scarlet	Medium
	3	2' Cal.	Pink Locust <i>Robinia x ambigua</i>	Low - Medium
	8	2' Cal.	Redbud <i>Cercis occidentalis</i> Pink pom pom	Very low - Medium
Total Trees	41			
SHRUBS				
	7	5 gal.	Apache Plume <i>Fallugia paradoxa</i>	Low
	21	5 gal.	Buffalo Juniper <i>Juniperus sabinna</i> Buffalo	Low
	2	5 gal.	Dwarf Butterfly Bush <i>Buddleja davidii</i>	Medium
	15	5 gal.	Feather Reed Grass <i>Calamagrostis arundinacea</i>	
	4	5 gal.	Fernbush <i>Chamaebotaria millefolium</i>	Very low - Low
	7	5 gal.	Indian Hawthorn <i>Raphiolepis indica</i>	Low
	7	5 gal.	Knock Out Rose <i>Rosa shrub</i> Knock Out	Medium
	2	5 gal.	Palm Yucca <i>Yucca faxoniana</i>	Very low - Low
	12	5 gal.	Wintergreen Barberry <i>Berberis julianae</i>	Medium
Total Shrubs	71			

	1	2-3cf	Boulders To be placed at contractor discretion
	3240		Landscape Gravel / No Filter Fabric 3/4" Crushed Grey Submit samples of gravel and cobble for approval
	1184		Oversize Landscape Gravel / No Filter Fabric 2-4" Valley Gold, Accent Cobble around Palm Yucca Submit samples of gravel and cobble for approval
	11024		Total Landscape Area Provided

LANDSCAPE CALCULATIONS

TOTAL LOT AREA (sf)	82328
LANDSCAPE REQUIREMENT	X0.10
TOTAL LANDSCAPE REQUIRED (10%)	8233
TOTAL ON-SITE LANDSCAPE PROVIDED	11321
TOTAL LIVE PLANT COVER REQUIRED (75%)	8,495
TOTAL LIVE PLANT COVER PROVIDED	12,624
PA PARKING SPACES	
PARKING TREE REQUIRED	9
PROVIDED	10

LANDSCAPE NOTES:
Landscape maintenance shall be the responsibility of the Property Owner. The Property Owner shall maintain landscaping in a living, healthy, and attractive condition.

It is the intent of this plan to comply with the City of Rio Rancho Water, IDO Ordinance.

It is the intent of this plan to comply with the City of Rio Rancho Landscape Regulations Applicable to Apartments and Nonresidential.

Water management is the sole responsibility of the Property Owner.

Landscape Gravel over Filter Fabric to a minimum depth of 3" shall be placed in all landscape areas which are not designated to receive native seed, or other treatment.

Contractor shall supply to the owner samples and prices of various gravel samples for approval prior to installing.

Landscape shall be watered by a complete underground irrigation system operated by automatic timer.

1/2 Trees shall have Netafim and shrubs shall have a minimum of 2 emitters per shrub.

Trees and shrubs shall be zoned separately.

Point of connection for irrigation system is unknown at current time and shall be coordinated between the Landscape Contractor and the General Contractor of the project prior to construction.

Landscaping shall be installed according to the approved plan: Installation shall be completed within 60 days of the related building's occupancy.

No substitutions or alterations to this plan without the express written permission of the Landscape Architect, and approval of the City of Rio Rancho, approved permit set.

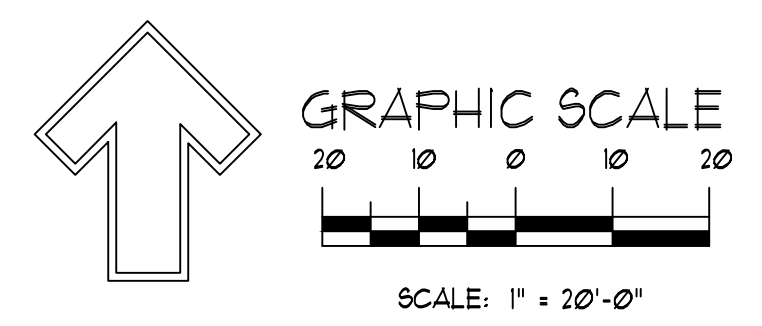

REVISIONS	Date:	Comment

Designed By: J.D. Mitchell
 Drawn By: J.D. Mitchell
 Approved By: J.D. Mitchell
 Date: 2/21/2025
 NEW MEXICO ONE CALL
 1-800-331-ALERT (2527)
 www.nmonecall.org
 Call two working days before you dig.
 File ID:

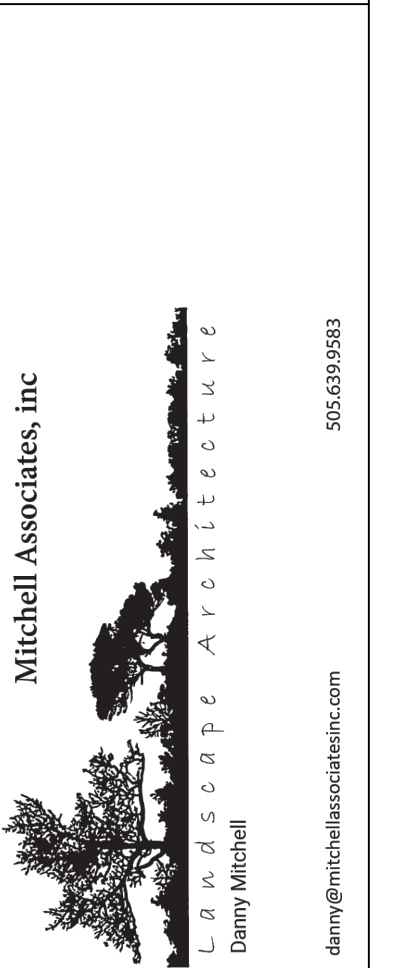

Seal:
 Landscape Architect
 STATE OF NEW MEXICO
 DANNY D. MITCHELL
 239
 REGISTERED
 LANDSCAPE ARCHITECT
 Feb. 21, 2025

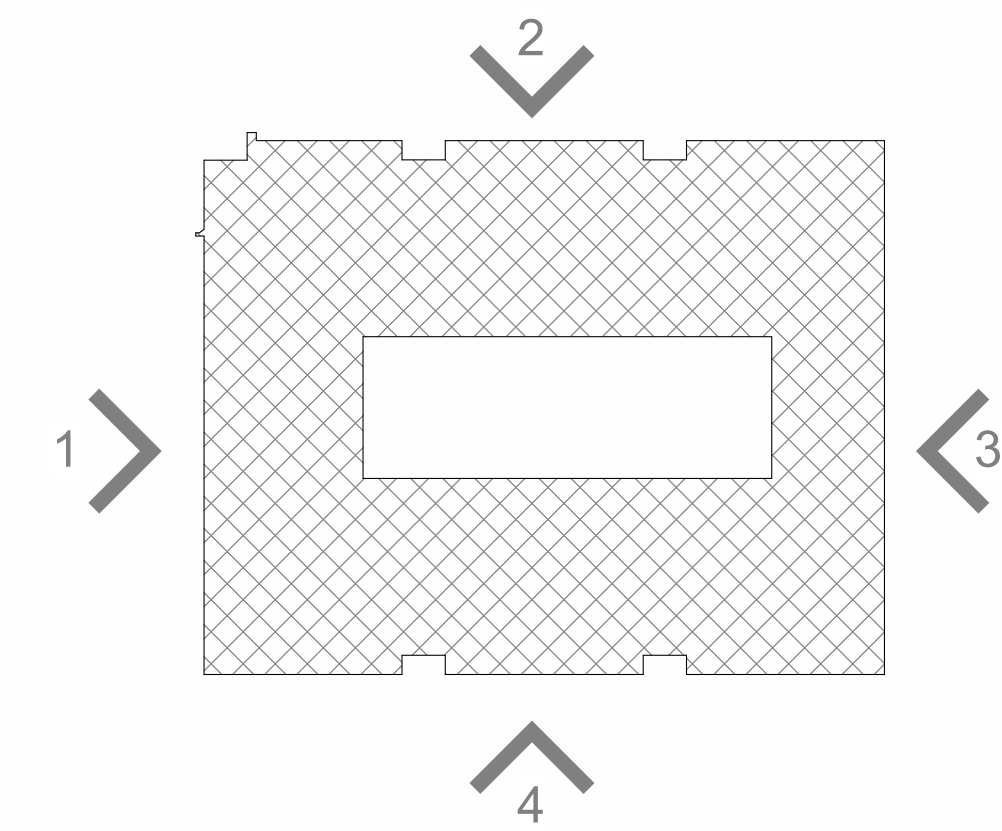

KEYPLAN

COLOR MATERIAL LEGEND

	EIFS 01	BENJAMIN MOORE 1422 "VIOLET SPARKLE"
	EIFS 02	BENJAMIN MOORE 2118-40 "SEA LIFE"
	EIFS 03	BENJAMIN MOORE 2118-50 "EXCALIBUR GRAY"
	EIFS 04	BENJAMIN MOORE 2063-20 "DOWNPOUR BLUE"
	CB 01	HARDIE BOARD LAP SIDING - BENJAMIN MOORE 2118-50 "EXCALIBUR GRAY", 6" BOARD, SMOOTH FINISH
	CB 02	HARDIE BOARD LAP SIDING - BENJAMIN MOORE 2118-40 "SEA LIFE", 6" BOARD, SMOOTH FINISH
	CB 03	HARDIE BOARD LAP SIDING - BENJAMIN MOORE 1422 "VIOLET SPARKLE", 6" BOARD, SMOOTH FINISH
	CB 04	HARDIE BOARD TRIM - COLOR WHITE

- STOREFRONT: ALL STOREFRONT TO BE WHITE IN COLOR.
- DOOR FRAMES: ALL DOOR FRAMES TO BE PAINTED WHITE.
- SUITE DOORS: PAINTED BM 2118-40 "SEA LIFE"
- ACCESSORY DOORS: PAINTED BM 1422 "VIOLET SPARKLE" (U.N.O)
- LOUVERS: PAINTED TO MATCH ADJACENT WALL
- GUARDRAIL: WHITE IN COLOR
- DOWNSPOUTS: WHITE IN COLOR
- SCUPPERS: PAINT TO MATCH ADJACENT WALL

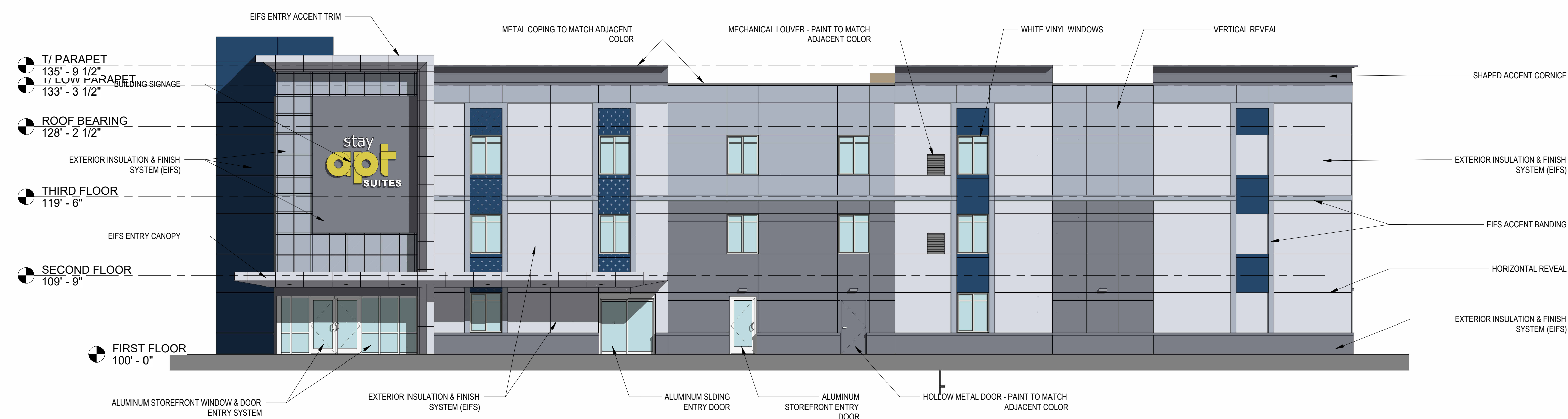

1 FRONT ELEVATION
1/8" = 1'-0"



2 LEFT ELEVATION
1/8" = 1'-0"

COLOR ELEVATIONS

stayAPT SUITES | 88 KEY PROTOTYPE

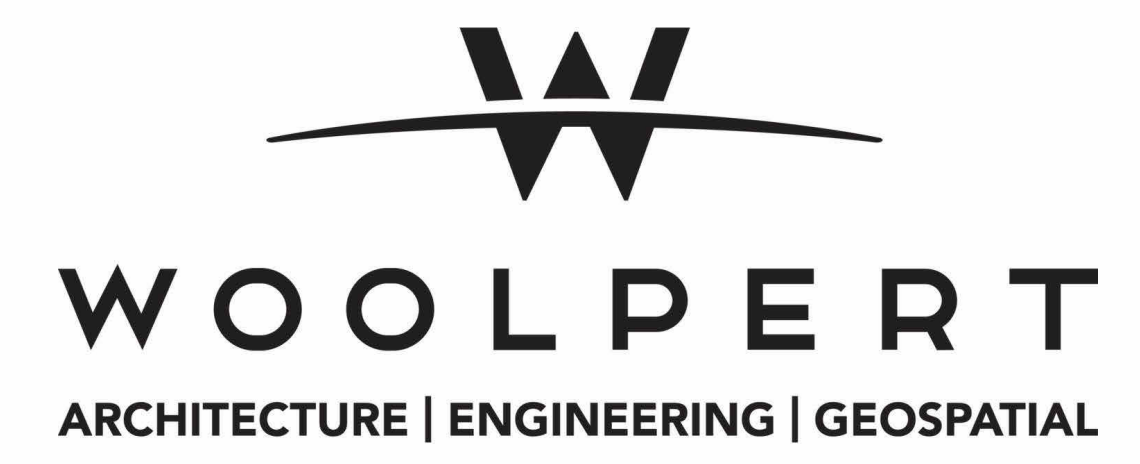

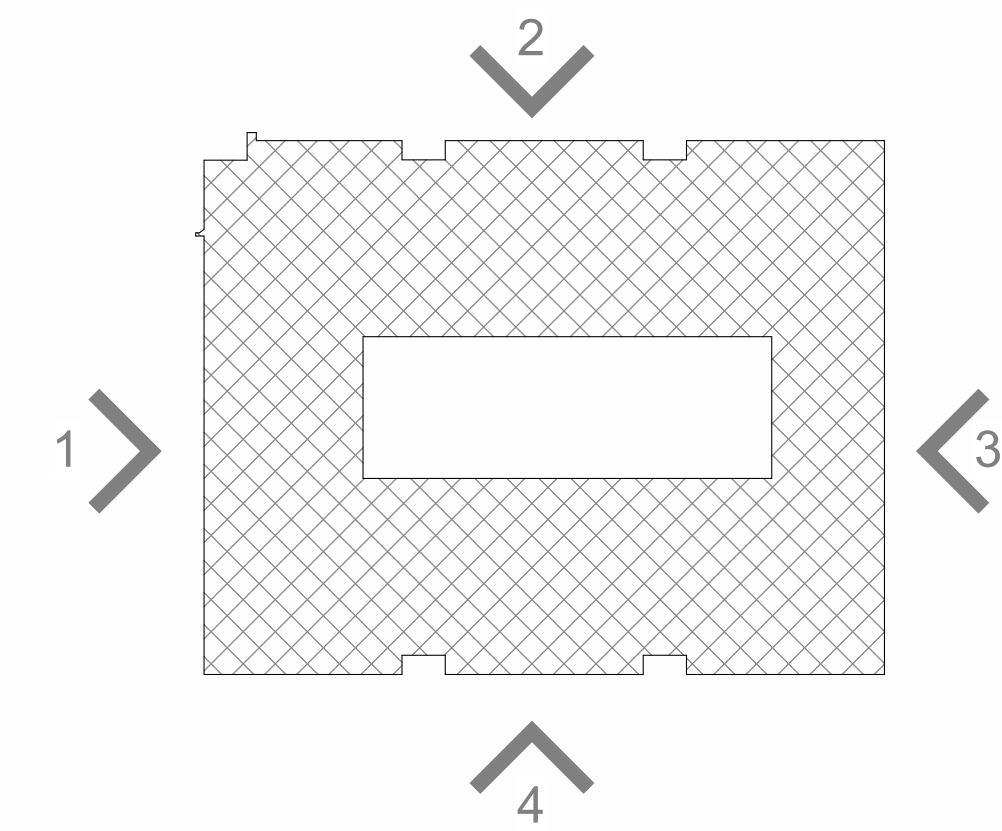

KEYPLAN

COLOR MATERIAL LEGEND

- EIFS 01 BENJAMIN MOORE 1422 "VIOLET SPARKLE"
- EIFS 02 BENJAMIN MOORE 2118-40 "SEA LIFE"
- EIFS 03 BENJAMIN MOORE 2118-50 "EXCALIBUR GRAY"
- EIFS 04 BENJAMIN MOORE 2063-20 "DOWNPOUR BLUE"
- CB 01 HARDIE BOARD LAP SIDING - BENJAMIN MOORE 2118-50 "EXCALIBUR GRAY", 6" BOARD, SMOOTH FINISH
- CB 02 HARDIE BOARD LAP SIDING - BENJAMIN MOORE 2118-40 "SEA LIFE", 6" BOARD, SMOOTH FINISH
- CB 03 HARDIE BOARD LAP SIDING - BENJAMIN MOORE 1422 "VIOLET SPARKLE", 6" BOARD, SMOOTH FINISH
- CB 04 HARDIE BOARD TRIM - COLOR WHITE

- STOREFRONT ALL STOREFRONT TO BE WHITE IN COLOR.
- DOOR FRAMES ALL DOOR FRAMES TO BE PAINTED WHITE.
- SUITE DOORS PAINTED BM 2118-40 "SEA LIFE"
- ACCESSORY DOORS PAINTED BM 1422 "VIOLET SPARKLE" (U.N.O)
- LOUVERS PAINTED TO MATCH ADJACENT WALL
- GUARDRAIL WHITE IN COLOR
- DOWNSPOUTS WHITE IN COLOR
- SCUPPERS PAINT TO MATCH ADJACENT WALL

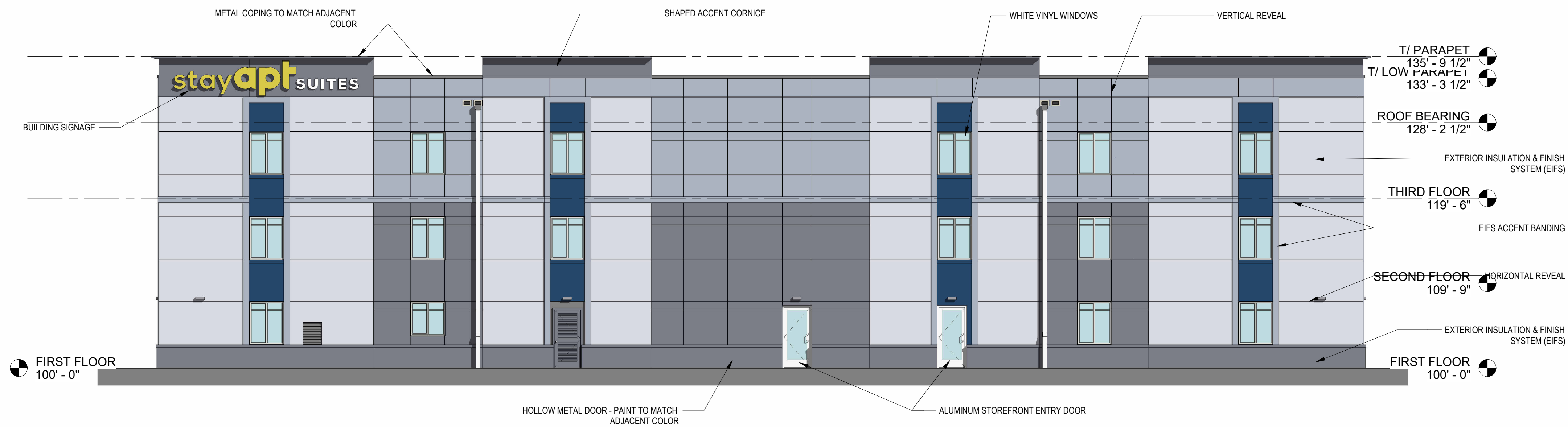

3 REAR ELEVATION
1/8" = 1'-0"

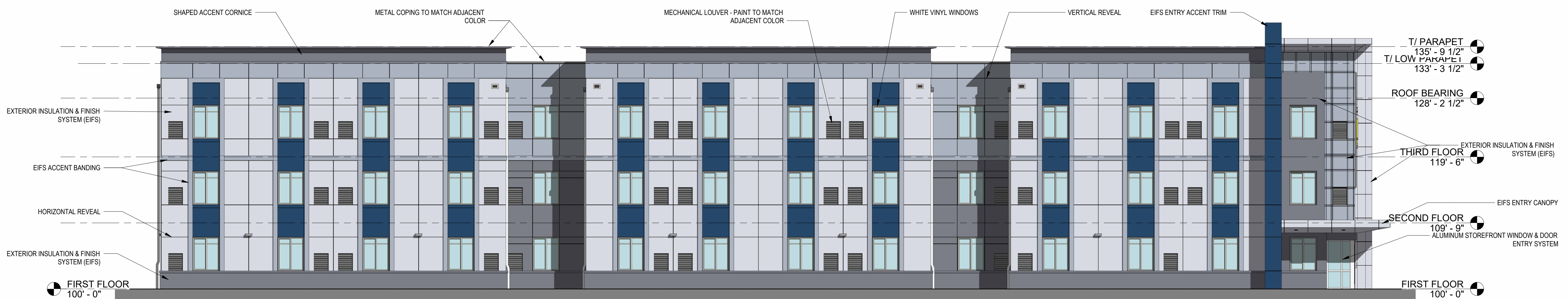

4 RIGHT ELEVATION
1/8" = 1'-0"

COLOR ELEVATIONS

stayAPT SUITES | 88 KEY PROTOTYPE

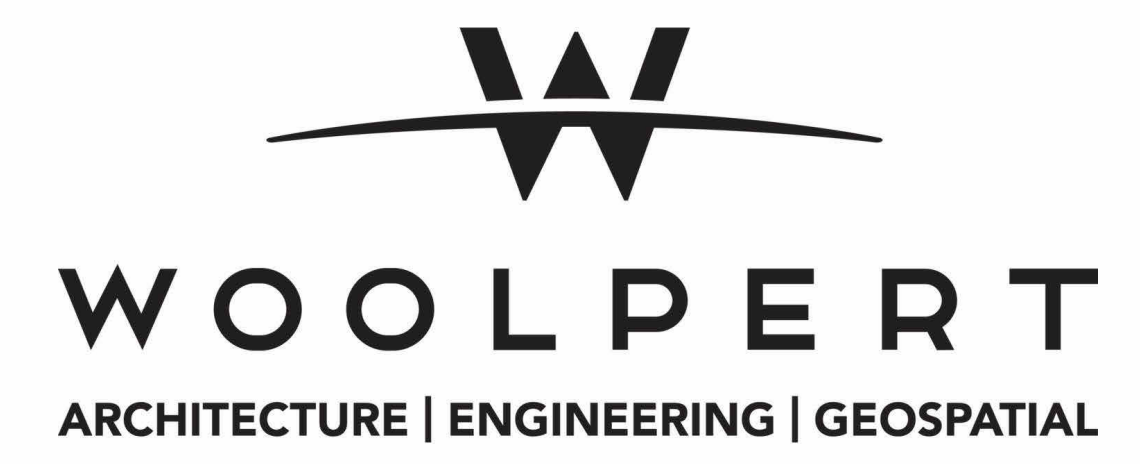



The City of Rio Rancho

**Development Services
Planning Division**

3200 Civic Center Circle NE
Rio Rancho, NM 87144
Phone (505) 891-5005 • Fax (505) 896-8994

RE: Site Plan, Case No. 25-160-00002
360 Ridgeway Dr SE

Dear Property Owner:

You are receiving this certified notice because your property abuts a site where a land development decision is required by the Governing Body.

The applicant, Yogash Kumar, through their agent, Clark Consulting Engineers, is requesting a site plan approval for an extended stay hotel at the property legally described as High Resort Market Place, Block A, tract B1 and addressed as 360 Ridgeway Dr SE. The property is zoned SU: Special Use for C-1 Regional Shopping Center and is approximately 1.90 acres.

The **Governing Body** will consider the request and have the final approval on **Thursday, April 10, 2025** at 6:00 pm in the **Council Chambers** and **Virtually** as a hybrid meeting, through the **Zoom link and number below**.

On the back of this letter is a location map of the project, with the subject property identified with a red outline.

If you would like to comment on this application, you are encouraged to send in comments in writing, which will be presented to the Governing Body. This Governing Body meeting will be hybrid with options to participate virtually or in person. The City highly encourages citizens to watch the meeting live on the City's website www.rnm.gov or on Sparklight cable channel 56.

For the **Governing Body meeting**, to participate virtually: Join via computer:
<https://us06web.zoom.us/j/85302353741?pwd=bWp1QXliSGJoeHhJaGV0czF4MDN0UT09>
Meeting ID: 853 0235 3741 Passcode: 789419 Join via phone: 1-346-248-7799 US

Please contact me via e-mail me at mcostilla@rnm.gov or call me at 505-896-8362, if you have any questions concerning this matter. The agenda for this hearing and related staff reports will be posted on the City's website, www.rnm.gov, the Friday before the hearing.

If you are an individual with a disability who is in need of a reader, amplifier, qualified sign language interpreter, or any form of auxiliary aid or service to attend or participate in the hearing or meeting, please contact the City Clerk, 505-891-5004, as soon as possible prior to the meeting. Please contact the City Clerk if a summary or other type of accessible format is needed.

Respectfully,

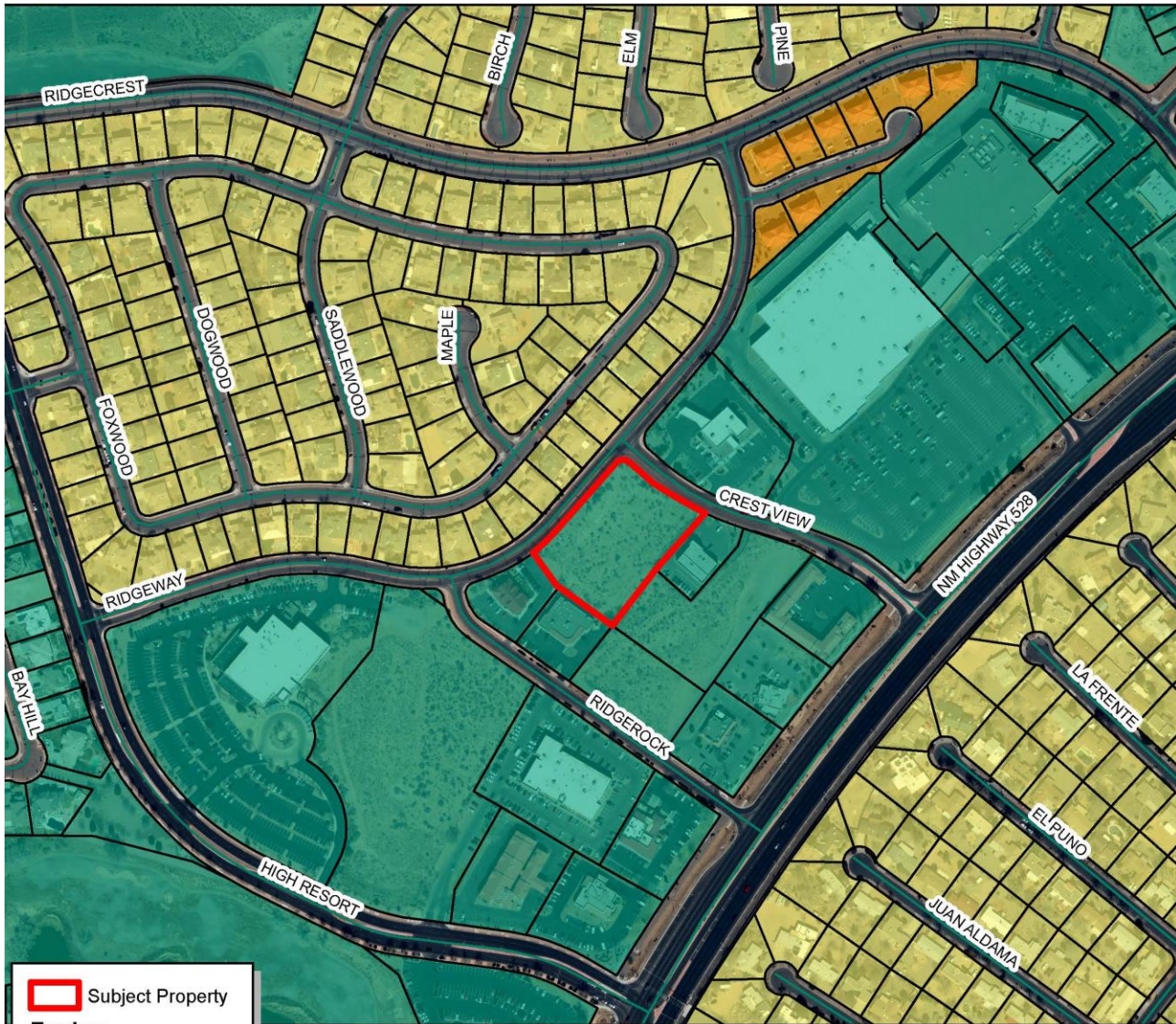

Michelle Costilla
Municipal Planner II
Development Services Department
City of Rio Rancho

360 RIDGEWAY DR SE



 Subject Property

Zoning

-  R-1
-  R-3
-  SU

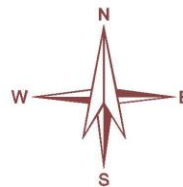

DISCLAIMER: All information in this map is provided "as is" without warranty or any representation of accuracy, timeliness or completeness. This map is not a survey and should be used for graphical purposes only.

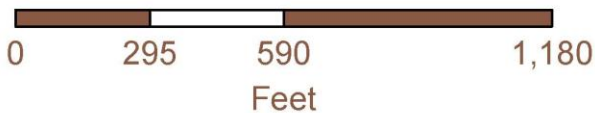



The GOVERNING BODY of the CITY of RIO RANCHO will consider the following matter at its regularly scheduled meeting at 6:00 p.m. on Thursday, April 10, 2025:

Site Plan
Case #25-160-00002



The applicant, Yogash Kumar, through their agent, Clark Consulting Engineers, is requesting a site plan approval for an extended stay hotel at the property legally described as High Resort Market Place, Block A, tract B1 and addressed as 360 Ridgeway Dr SE. The property is zoned SU: Special Use for C-1 Regional Shopping Center and is approximately 1.90 acres..

The meeting is scheduled in the Council Chambers at City Hall, 3200 Civic Center Cir. NE, Rio Rancho, NM. The public is invited to attend in person or virtually at www.rnm.gov. Materials related to this item are available for viewing in the Development Services Department at City Hall.

If you would like to comment on this application, you are encouraged to submit a written comment to planning@rnm.gov. Written comments will be inserted into the public record.
Journal: March 26, 2025

360 RIDGEWAY DR SE



-  Subject Property
-  Adjacent Properties

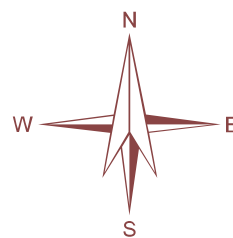

DISCLAIMER: All information in this map is provided "as is" without warranty or any representation of accuracy, timeliness or completeness. This map is not a survey and should be used for graphical purposes only.





**CITY OF RIO RANCHO
ORDINANCE**

RESOLUTION NO. PZB-14

ENACTMENT NO. 23-01 PZB

A RESOLUTION OF THE PLANNING AND ZONING BOARD ACCEPTING AND APPROVING THE STAFF INTERPRETATION THAT “HOTELS AND MOTELS” BE CONSIDERED A PERMISSIVE USE ON THE LAND SUBJECT TO SU: SPECIAL USE REGULATIONS ESTABLISHED BY ORDINANCE 86-002, AND PROVIDING FOR AN EFFECTIVE DATE

WHEREAS: the Rio Rancho Code of Ordinances (R.O. 2003) Section 154.02 establishes an Official Zoning Map and provides for application of the Zoning Chapter 154; and,

WHEREAS: R.O. 2003, Section 154.02(G) states that “Any legitimate commercial use not prohibited in the established commercial zoning districts of this code, but not falling within the specific permitted or conditional uses and which is shown to be compatible with listed permitted and/or conditional uses and furthers the interests of the citizens of Rio Rancho in order to secure the advantages of local self-government with paramount consideration given to the health, comfort, wellbeing, and quality of life for the citizens, may be authorized as a permitted or conditional use by the Director of the City Development Department or his/her designee following notification and approval by the Planning and Zoning Board as an agenda item at a regular or special meeting”; and

WHEREAS: the Special Use Ordinance 86-002 states that a “Conceptual Development Plan be granted and the entire development area reflect SU (Special Use) for the designated uses as presented on the attached map, and according to the attached Master Zoning Map, the subject property is within the C-1 Regional Shopping Center; and

WHEREAS: the Development Services Department has determined that hotels and motels to be considered a permissive use on the land subject to SU: Special Use regulations established by Ordinance No. 86-002; and

WHEREAS: at a regular meeting held on June 13, 2023, the Planning and Zoning Board was notified of the interpretation and authorization; and

WHEREAS: the Planning and Zoning Board, having considered this authorization, has determined that this determination and authorization is in accordance with the requirements of R.O. 2003, and furthers the interests of the citizens of Rio Rancho in order to secure the advantages of local self-government and also promotes the health, safety, and general welfare of those citizens.

1
2
3
4
5
6
7
8
9
10
11
12
13
14
15
16
17
18
19
20
21
22
23
24
25
26
27
28
29
30
31
32
33
34
35
36
37
38
39
40
41
42
43
44

1
2 **NOW THEREFORE, BE IT ORDAINED BY THE GOVERNING BODY OF THE CITY OF**
3 **RIO RANCHO:**

4
5 **Section 1.** In accordance with Rio Rancho Code of Ordinances (R.O. 2003)
6 Section 154.02(G), and in support of the Director of Development Services
7 determination and authorization, the following permissive use is approved:

8
9 Hotels and motels are permitted uses on lands subject to SU: Special Use
10 District regulations established by Ordinance No.86-002. Applicants shall
11 provide a site plan which includes all requirements set forth in R.O. 2003
12 Section 154.43.

13
14 **Section 4. Effective Date.** This Ordinance shall become effective ten days after
15 adoption.

16
17 ADOPTED THIS 13th DAY OF JUNE, 2023.

18
19 
20 _____
21 Fred Radosevich, Chairman

22
23
24 ATTEST:

25 
26 _____
27 Amy Rincon, Director of Development Services
28

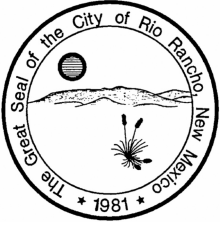

CITY OF RIO RANCHO COVER PAGE

Legislation Item: R35

AGENDA DATE:

April 10, 2025

DEPARTMENT:

Financial Services

SUBJECT:

R35, Resolution Amending the Permanent Fund Investment Policy Statement

BACKGROUND AND ANALYSIS:

Chapter 36 of the Municipal Code, Finance and Revenue outlines certain requirements for the City's Permanent Fund and Investment Policy Statement (IPS). The Permanent Fund IPS was last amended in August 2024.

The amendment seeks to expand the allowable investments in which the Permanent Fund can be invested, and re-establishes the asset weighting ranges and target weights for existing and newly added asset classes. The revisions allow for investments to be made in "other" categories within both growth and income asset classes (e.g., real return assets, real estate investment trusts (REITs)), allowing for a range of 0 - 20 percent of assets in the class to be invested in such classes with a target of 6 percent in the growth class and 0 percent in the income class. Additional flexibility in these classes will enable investment across a broader range of investments adding diversification opportunities and the ability to more effectively guard against the impact of adverse market conditions. There are no changes to the "Prohibited Investments" of the IPS.

In addition, the amendment will remove language referencing use of an actuarial discount rate as the basis for the fund's performance objective.

The City intends to continue to utilize the State Investment Council investment pools for the Permanent Fund. The revisions to the IPS were recommended by the City's Permanent Fund investment advisor during its annual review. The proposed amendments were reviewed and considered by the City's Investment Advisory Board at its February 26, 2025 meeting. The Board voted unanimously to recommend the IPS amendments to the Governing Body.

IMPACT:

Broadens the allowable investments for the Permanent Fund and modifies the basis for the Fund's performance objectives.

ALTERNATIVES:

Approve the Resolution.

Do not approve the Resolution.

DEPARTMENT RECOMMENDATION:

Staff recommends approval of the Resolution.

ATTACHMENT: [Resolution_R35](#)

ATTACHMENT: [2025 Rio Rancho IPS - Revision](#)

ATTACHMENT: [2024 Rio Rancho IPS - Revision](#)



**CITY OF RIO RANCHO
RESOLUTION**

RESOLUTION NO.

ENACTMENT NO.

**RESOLUTION AMENDING THE PERMANENT FUND INVESTMENT
POLICY STATEMENT**

WHEREAS: Chapter 36 Finance Revenue of the Municipal Code outlines certain requirements for the City’s Permanent Fund Investment Policy Statement; and

WHEREAS: Chapter 6-10-10 (G) NMSA 1978 states “It shall be the duty of the treasurer to bring amendments to the investment policy to the board of finance and obtain consent before such amendments take effect. The investment policy shall be reviewed at least every two years...”; and

WHEREAS: the Permanent Fund Investment Policy Statement was approved in September 2022; and

WHEREAS: the Permanent Fund Investment Policy Statement was revised in August 2024, however changes to the asset classes, weighting ranges and target were not contemplated at that time; and

WHEREAS: market concerns make it prudent to expand the allowable investments in the Permanent Fund to enable further diversification to guard against the impact of adverse market conditions; and

WHEREAS: the Investment Advisory Board has provided input, reviewed and approved the amendments to the Investment Policy Statement.

**NOW THEREFORE, BE IT RESOLVED BY THE GOVERNING BODY OF THE CITY OF
RIO RANCHO:**

The Governing Body, acting as the Board of Finance, does hereby approve the amended Investment Policy Statement attached hereto.

ADOPTED THIS _____ DAY OF _____ 2025.

Greggory D. Hull, Mayor

ATTEST:

Noel C. Davis, City Clerk
(SEAL)

INVESTMENT POLICY STATEMENT
FOR
CITY OF RIO RANCHO VISION FUND

Adopted August 22, 2024 April 10, 2025

TABLE OF CONTENTS

<u>SECTION</u>	<u>PAGE</u>
Purpose.....	1
Investment Authority	1
Statement of Investment Objectives	2
Investment Guidelines.....	2
Initial Investment of Funds	
Time Horizon	
Liquidity and Diversification	
Asset Allocation	
Rebalancing Philosophy	
Risk Tolerance	
Performance Expectations	
Selection of Investment Managers.....	5
Guidelines for Portfolio Holdings.....	5
Direct Investments by Advisor	
Limitations on Managers' Portfolios	
Portfolio Risk Hedging	
Prohibited Portfolio Investments	
Safekeeping	
Control Procedures.....	6
Review of Investment Objectives	
Review of Investment Performance	
Voting of Proxies	
Adoption of Investment Policy Statement	7

The City of Rio Rancho has established a Permanent Fund, known as the City of Rio Rancho Vision Fund (the “Fund”). This Fund will be used to invest monies to support the City’s general operations. The Fund consists of General Fund reserves resulting from positive revenue variances (revenue in excess of budget) and positive expense variances (expenses less than budget) accumulated in excess of policy targets. The City of Rio Rancho Governing Body hereby adopts this Investment Policy Statement (“Policy Statement”) for the following purposes.

Purpose

The main investment objective of the Fund is to achieve long-term growth of Fund assets by maximizing long-term rate of return on investments and minimizing risk of loss, especially as the monies are initially invested, and to provide funding for general government purposes as determined by the Governing Body.

The purpose of this Policy Statement is to achieve the following:

1. Document investment objectives, performance expectations, and investment guidelines for Fund assets.
2. Establish an appropriate investment strategy for managing all Fund assets, including an investment time horizon, risk tolerance ranges, and asset allocation to provide sufficient diversification and overall return over the long-term time horizon of the Fund.
3. Establish investment guidelines to control overall risk and liquidity.
4. Establish periodic performance reporting requirements to monitor investment results and confirm that the investment policy is being followed.
5. Comply with fiduciary, prudence, due diligence, and legal requirements for Fund assets.

Investment Authority

The City of Rio Rancho Governing Body will oversee certain policies and procedures related to the operation and administration of the Fund. The Governing Body will have authority to implement the investment policy and guidelines in the best interest of the Fund to best satisfy the purposes of the Fund. In implementing this Policy Statement, the Governing Body believes it may delegate certain functions to:

1. The City Treasurer, as defined in Section 6.01 of the City Charter as the Director of the

Department of Financial Services. The Treasurer shall be responsible for all transactions undertaken and shall establish an investment policy statement to set the specific policy requirements and guidelines for the investment of the City's Permanent Fund and a system of controls to regulate the activities of subordinate officials.

2. The Investment Advisory Board established pursuant to Chapter 33 of the City Code of Ordinances. The Investment Advisory Board shall review the investment policy statement annually and provide input to the Governing Body regarding proposed changes, provide input on the use of distributions from the Fund, and review and provide input on administration and management of the Fund.
3. The New Mexico State Investment Council ("NMSIC"), as investment advisor.
4. A consultant to assist with periodic review of a) the investment policy statement, b) the performance of the investment portfolio, and c) the asset allocation guidelines including recommendations to rebalance the portfolio as referenced in the "Periodic Re-balancing" section. The consultant may be a contracted individual or company with specific subject matter experience, procured by the City to provide expertise for the listed functions.
5. A trustee appointed by the Fund, such as a bank trust department, if the Fund does not have its own Trustees, to assume fiduciary responsibility for the administration of Fund assets; provided, however, that if the Governing Body shall have appointed an investment advisor, then any trustee appointed under this paragraph shall have no authority with respect to selection of investments.
6. Specialists such as attorneys, auditors, and other consultants to assist the Governing Body in meeting its responsibilities and obligations to administer Fund assets prudently.

Statement of Investment Objectives

The investment objectives of the Fund are as follows:

1. To invest assets of the Fund in a manner consistent with the following fiduciary standards: (a) all transactions undertaken must be for the sole interest of Fund beneficiaries, and (b) assets are to be diversified in order to minimize the impact of large losses from individual investments.
2. To provide for funding and anticipated withdrawals on a continuing basis for distribution to the City's General Fund and reasonable expenses of operation of the Fund.
3. To enhance the value of Fund assets in real terms over the long term through asset appreciation and income generation, while maintaining a reasonable investment risk profile.
4. Subject to performance expectations over the long term, to minimize principal fluctuations over the Time Horizon (defined under the section labeled "Time Horizon").
5. To achieve a long-term level of return commensurate with contemporary economic conditions and equal to or exceeding the investment objective set forth in this Policy Statement under the section labeled "Performance Expectations".

Investment Guidelines

Within this section of the Policy Statement, several terms will be used to articulate various investment concepts. The descriptions are meant to be general and may share investments otherwise considered to be in the same asset class. They are:

"Growth Assets" - a collection of investments and/or asset classes whose primary risk and return characteristics are focused on capital appreciation. Investments within the Growth Assets category can include income and risk mitigating characteristics, so long as the predominant investment risk and return characteristic is capital appreciation. Examples of such investments or asset classes are: domestic and international equities or equity funds, and certain real estate investments.

"Income Assets" - a collection of investments and/or asset classes whose primary risk and return characteristics are focused on income generation. Investments within the Income Assets category can include capital appreciation and risk mitigating characteristics, so long as the primary investment risk and return characteristic is income generation. Examples of such investments or asset classes are: fixed income securities, unconstrained bond strategies, structured credit securities, high yield corporate bonds, and opportunistic credit funds.

"Real Return Assets" - a collection of investments and/or asset classes whose primary risk and return characteristics are focused on real returns after inflation. Investments within the Real Return category can include infrastructure, timber, agriculture, energy, inflation-linked securities, commodities, and other similar assets.

Time Horizon

The Fund's investment objectives are based on a long-term investment horizon ("Time Horizon") of 20 years or longer. Interim fluctuations should be viewed with appropriate perspective. The Governing Body has adopted a long-term investment horizon such that the risks and duration of investment losses are carefully weighed against the long-term potential for appreciation of assets.

Liquidity and Diversification

In general, the Fund may hold some cash, cash equivalent, and/or money market funds for near-term Fund benefits and expenses (the "Fund Distributions"). Remaining assets will be invested in longer-term investments and shall be diversified with the intent to minimize the risk of long-term investment losses. Consequently, the total portfolio will be constructed and maintained to provide diversification with regard to the concentration of holdings in individual issues, issuers, countries, governments, or industries.

Asset Allocation

The Governing Body believes that to achieve the greatest likelihood of meeting the Fund’s investment objectives and the best balance between risk and return for optimal diversification, assets will be invested in accordance with the targets for each asset class as follows to achieve an average total annual rate of return that is equal to or greater than the Fund’s target rate of return over the long term, as described in the section titled “Performance Expectations.”

<u>Asset Classes</u>	<u>Asset Weightings</u>	
	<u>Range</u>	<u>Target</u>
Growth Assets		
Domestic Equity	<u>21</u> 4% - <u>51</u> 4%	<u>36</u> 9%
International Equity	6% - 36%	<u>18</u> 24%
<u>Other</u>	<u>0</u> %-20%	<u>6</u> %
Income Assets		
Fixed Income	25% - 55%	40%
<u>Other</u>	<u>0</u> %-20%	<u>0</u> %
Cash Equivalents	0% - 15%	0%

The NMSIC and each Manager will be evaluated against their peers on the performance of the total funds under their direct management.

Rebalancing Philosophy

The asset allocation range established by this Policy Statement represents a long-term perspective. As such, rapid unanticipated market shifts or changes in economic conditions may cause the asset mix to fall outside Policy Statement ranges. When allocations breach the specified ranges, the Consultant will recommend rebalancing the assets within the specified ranges. The Consultant may also recommend rebalancing based on market conditions. Limitations on the timing and frequency of rebalancing due to the operational procedures permitted by NMSIC are anticipated, and will be taken into account by the Consultant before each rebalance recommendation.

Risk Tolerance

Subject to investment objectives and performance expectations, the Fund will be managed in a style that seeks to minimize principal fluctuations over the established Time Horizon.

Performance Expectations

~~Over the long term, five years or longer, the performance objective for the Fund will be to achieve an average total annual rate of return that is equal to or greater than the Fund's actuarial discount rate. Additionally, it~~ is expected that the annual rate of return on Fund assets will be commensurate with the then prevailing investment environment. Measurement of this return expectation will be judged by reviewing returns in the context of industry standard benchmarks, peer universe comparisons for individual Fund investments, and blended benchmark comparisons for the Fund in its entirety.

Selection of Investment Managers

The Consultant shall prudently recommend appropriate Managers offered by NMSIC to invest the assets of the Fund.

Guidelines for Portfolio Holdings

Recommended Investments by Consultant

Every effort shall be made, to the extent practical, prudent, and appropriate, to select investments that have investment objectives and policies that are consistent with this Policy Statement (as outlined in the following sub-sections of the "Guidelines for Portfolio Holdings"). However, given the nature of the investments available through the NMSIC, it is recognized that there may be deviations between this Policy Statement and the objectives of these investments.

Limitations on Managers' Portfolios

EQUITIES

Domestic Equities. Other than the above constraints, there are no quantitative guidelines as to issues, industry, or individual security diversification. However, prudent diversification standards should be developed and maintained by each NMSIC Manager.

International Equities. The overall non-U.S. equity allocation should include a diverse global mix that is comprised of the equity of companies from multiple countries, regions, and sectors.

FIXED INCOME

The overall rating of the fixed income assets shall be investment grade, based on the rating of one Nationally Recognized Statistical Rating Organization ("NRSRO").

CASH EQUIVALENTS

Cash equivalents shall be held in funds complying with Rule 2(a)-7 of the Investment Company Act of 1940.

Prohibited Investments

Except for purchase within authorized investments, securities having the following characteristics are not authorized and shall not be purchased: letter stock and other unregistered securities, direct commodities or commodity contracts, or private placements (with the exception of Rule 144A securities). Further, derivatives, options, or futures for the sole purpose of direct portfolio leveraging are prohibited. Direct ownership of real estate, natural resource properties such as oil, gas, or timber and the purchase of collectibles is also prohibited.

Control Procedures

Review of Investment Objectives

The Consultant shall review annually and report to the Investment Advisory Board and Governing Body the appropriateness of this Policy Statement for achieving the Fund's stated objectives. It is not expected that this Policy Statement will change frequently. In particular, short-term changes in the financial markets should not require an adjustment in this Policy Statement.

Review of Investment Performance

The Consultant shall report on a quarterly basis to the Investment Advisory Board to review the investment performance of the Fund.

The Consultant shall compare the investment results on a quarterly basis to appropriate peer universe benchmarks, as well as market indices in both equity and fixed income markets. Examples of benchmarks and indexes that will be used include the Russell 3000 Index for broad U.S. equity strategies, S&P 500 Index for large cap U.S. equities, Russell 2000 Index for small cap U.S. equities, MSCI ACWI ex-U.S. Index for broad based non-U.S. equity strategies, MSCI Europe, Australasia, and Far East (EAFE) Index for developed markets international equities, Bloomberg U.S. Aggregate Bond Index for fixed income securities, and the U.S. 91 Day T-bill for cash equivalents. The Russell 3000 Index will be used to benchmark the U.S. equities portfolio; the MSCI ACWI ex-U.S. Index will be used to benchmark the non-U.S. equities portfolio; and the Bloomberg U.S. Aggregate Bond Index will be used to benchmark the fixed income portfolio. The categories "Other" will be benchmarked against appropriate indices depending on the specific characteristics of the strategies and funds used.

Voting of Proxies

The Governing Body recognizes that proxies are a significant and valuable tool in corporate governance. The voting rights of individual stocks held in separate accounts or collective, common, or

pooled funds will be exercised by the investment managers in accordance with their own proxy voting policies. The voting rights of funds will be exercised by the NMSIC.

Other Requirements

The Governing Body will establish additional controls and requirements as necessary for any investments outside of the management of the State Investment Council. These requirements will include permissible investments, safekeeping requirements, requirements for delivery versus payment of investment trades, and collateralization.

Adoption of Investment Policy Statement

Any changes and exceptions to this Policy Statement will be made in writing and adopted by the Governing Body via resolution. This Investment Policy Statement was adopted on ~~September 22~~April 10, 2022 via Resolution 20225- .

INVESTMENT POLICY STATEMENT
FOR
CITY OF RIO RANCHO VISION FUND

Adopted August 22, 2024

TABLE OF CONTENTS

<u>SECTION</u>	<u>PAGE</u>
Purpose	1
Investment Authority	1
Statement of Investment Objectives	2
Investment Guidelines	2
Initial Investment of Funds	
Time Horizon	
Liquidity and Diversification	
Asset Allocation	
Rebalancing Philosophy	
Risk Tolerance	
Performance Expectations	
Selection of Investment Managers.....	5
Guidelines for Portfolio Holdings	5
Direct Investments by Advisor	
Limitations on Managers' Portfolios	
Portfolio Risk Hedging	
Prohibited Portfolio Investments	
Safekeeping	
Control Procedures	6
Review of Investment Objectives	
Review of Investment Performance	
Voting of Proxies	
Adoption of Investment Policy Statement.....	7

The City of Rio Rancho has established a Permanent Fund, known as the City of Rio Rancho Vision Fund (the “Fund”). This Fund will be used to invest monies to support the City’s general operations. The Fund consists of General Fund reserves resulting from positive revenue variances (revenue in excess of budget) and positive expense variances (expenses less than budget) accumulated in excess of policy targets. The City of Rio Rancho Governing Body hereby adopts this Investment Policy Statement (“Policy Statement”) for the following purposes.

Purpose

The main investment objective of the Fund is to achieve long-term growth of Fund assets by maximizing long-term rate of return on investments and minimizing risk of loss, especially as the monies are initially invested, and to provide funding for general government purposes as determined by the Governing Body.

The purpose of this Policy Statement is to achieve the following:

1. Document investment objectives, performance expectations, and investment guidelines for Fund assets.
2. Establish an appropriate investment strategy for managing all Fund assets, including an investment time horizon, risk tolerance ranges, and asset allocation to provide sufficient diversification and overall return over the long-term time horizon of the Fund.
3. Establish investment guidelines to control overall risk and liquidity.
4. Establish periodic performance reporting requirements to monitor investment results and confirm that the investment policy is being followed.
5. Comply with fiduciary, prudence, due diligence, and legal requirements for Fund assets.

Investment Authority

The City of Rio Rancho Governing Body will oversee certain policies and procedures related to the operation and administration of the Fund. The Governing Body will have authority to implement the investment policy and guidelines in the best interest of the Fund to best satisfy the purposes of the Fund. In implementing this Policy Statement, the Governing Body believes it may delegate certain functions to:

1. The City Treasurer, as defined in Section 6.01 of the City Charter as the Director of the Department of Financial Services. The Treasurer shall be responsible for all transactions undertaken and shall establish an investment policy statement to set the specific policy

- requirements and guidelines for the investment of the City's Permanent Fund and a system of controls to regulate the activities of subordinate officials.
2. The Investment Advisory Board established pursuant to Chapter 33 of the City Code of Ordinances. The Investment Advisory Board shall review the investment policy statement annually and provide input to the Governing Body regarding proposed changes, provide input on the use of distributions from the Fund, and review and provide input on administration and management of the Fund.
 3. The New Mexico State Investment Council ("NMSIC"), as investment advisor.
 4. A consultant to assist with periodic review of a) the investment policy statement, b) the performance of the investment portfolio, and c) the asset allocation guidelines including recommendations to rebalance the portfolio as referenced in the "Periodic Re-balancing" section. The consultant may be a contracted individual or company with specific subject matter experience, procured by the City to provide expertise for the listed functions.
 5. A trustee appointed by the Fund, such as a bank trust department, if the Fund does not have its own Trustees, to assume fiduciary responsibility for the administration of Fund assets; provided, however, that if the Governing Body shall have appointed an investment advisor, then any trustee appointed under this paragraph shall have no authority with respect to selection of investments.
 6. Specialists such as attorneys, auditors, and other consultants to assist the Governing Body in meeting its responsibilities and obligations to administer Fund assets prudently.

Statement of Investment Objectives

The investment objectives of the Fund are as follows:

1. To invest assets of the Fund in a manner consistent with the following fiduciary standards: (a) all transactions undertaken must be for the sole interest of Fund beneficiaries, and (b) assets are to be diversified in order to minimize the impact of large losses from individual investments.
2. To provide for funding and anticipated withdrawals on a continuing basis for distribution to the City's General Fund and reasonable expenses of operation of the Fund.
3. To enhance the value of Fund assets in real terms over the long term through asset appreciation and income generation, while maintaining a reasonable investment risk profile.
4. Subject to performance expectations over the long term, to minimize principal fluctuations over the Time Horizon (defined under the section labeled "Time Horizon").
5. To achieve a long-term level of return commensurate with contemporary economic conditions and equal to or exceeding the investment objective set forth in this Policy Statement under the section labeled "Performance Expectations".

Investment Guidelines

Within this section of the Policy Statement, several terms will be used to articulate various investment concepts. The descriptions are meant to be general and may share investments otherwise considered to be in the same asset class. They are:

"Growth Assets" - a collection of investments and/or asset classes whose primary risk and return characteristics are focused on capital appreciation. Investments within the Growth Assets category can include income and risk mitigating characteristics, so long as the predominant investment risk and return characteristic is capital appreciation. Examples of such investments or asset classes are: domestic and international equities or equity funds, and certain real estate investments.

"Income Assets" - a collection of investments and/or asset classes whose primary risk and return characteristics are focused on income generation. Investments within the Income Assets category can include capital appreciation and risk mitigating characteristics, so long as the primary investment risk and return characteristic is income generation. Examples of such investments or asset classes are: fixed income securities, unconstrained bond strategies, structured credit securities, high yield corporate bonds, and opportunistic credit funds.

"Real Return Assets" - a collection of investments and/or asset classes whose primary risk and return characteristics are focused on real returns after inflation. Investments within the Real Return category can include infrastructure, timber, agriculture, energy, inflation-linked securities, commodities, and other similar assets.

Time Horizon

The Fund's investment objectives are based on a long-term investment horizon ("Time Horizon") of 20 years or longer. Interim fluctuations should be viewed with appropriate perspective. The Governing Body has adopted a long-term investment horizon such that the risks and duration of investment losses are carefully weighed against the long-term potential for appreciation of assets.

Liquidity and Diversification

In general, the Fund may hold some cash, cash equivalent, and/or money market funds for near-term Fund benefits and expenses (the "Fund Distributions"). Remaining assets will be invested in longer-term investments and shall be diversified with the intent to minimize the risk of long-term investment losses. Consequently, the total portfolio will be constructed and maintained to provide diversification with regard to the concentration of holdings in individual issues, issuers, countries, governments, or industries.

Asset Allocation

The Governing Body believes that to achieve the greatest likelihood of meeting the Fund's investment objectives and the best balance between risk and return for optimal diversification, assets will be invested in accordance with the targets for each asset class as follows to achieve an average total annual rate of return that is equal to or greater than the Fund's target rate of return over the long term, as described in the section titled "Performance Expectations."

<u>Asset Classes</u>	<u>Asset Weightings</u>	
	<u>Range</u>	<u>Target</u>
Growth Assets		
Domestic Equity	24% - 54%	39%
International Equity	6% - 36%	21%
Income Assets		
Fixed Income	25% - 55%	40%
Cash Equivalents	0% - 15%	0%

The NMSIC and each Manager will be evaluated against their peers on the performance of the total funds under their direct management.

Rebalancing Philosophy

The asset allocation range established by this Policy Statement represents a long-term perspective. As such, rapid unanticipated market shifts or changes in economic conditions may cause the asset mix to fall outside Policy Statement ranges. When allocations breach the specified ranges, the Consultant will recommend rebalancing the assets within the specified ranges. The Consultant may also recommend rebalancing based on market conditions. Limitations on the timing and frequency of rebalancing due to the operational procedures permitted by NMSIC are anticipated, and will be taken into account by the Consultant before each rebalance recommendation.

Risk Tolerance

Subject to investment objectives and performance expectations, the Fund will be managed in a style that seeks to minimize principal fluctuations over the established Time Horizon.

Performance Expectations

Over the long-term, five years or longer, the performance objective for the Fund will be to achieve an average total annual rate of return that is equal to or greater than the Fund's actuarial discount rate. Additionally, it is expected that the annual rate of return on Fund assets will be commensurate with the then prevailing investment environment. Measurement of this return expectation will be judged by reviewing returns in the context of industry standard benchmarks, peer universe comparisons for individual Fund investments, and blended benchmark comparisons for the Fund in its entirety.

Selection of Investment Managers

The Consultant shall prudently recommend appropriate Managers offered by NMSIC to invest the assets of the Fund.

Guidelines for Portfolio Holdings

Recommended Investments by Consultant

Every effort shall be made, to the extent practical, prudent, and appropriate, to select investments that have investment objectives and policies that are consistent with this Policy Statement (as outlined in the following sub-sections of the “Guidelines for Portfolio Holdings”). However, given the nature of the investments available through the NMSIC, it is recognized that there may be deviations between this Policy Statement and the objectives of these investments.

Limitations on Managers’ Portfolios

EQUITIES

Domestic Equities. Other than the above constraints, there are no quantitative guidelines as to issues, industry, or individual security diversification. However, prudent diversification standards should be developed and maintained by each NMSIC Manager.

International Equities. The overall non-U.S. equity allocation should include a diverse global mix that is comprised of the equity of companies from multiple countries, regions, and sectors.

FIXED INCOME

The overall rating of the fixed income assets shall be investment grade, based on the rating of one Nationally Recognized Statistical Rating Organization (“NRSRO”).

CASH EQUIVALENTS

Cash equivalents shall be held in funds complying with Rule 2(a)-7 of the Investment Company Act of 1940.

Prohibited Investments

Except for purchase within authorized investments, securities having the following characteristics are not authorized and shall not be purchased: letter stock and other unregistered securities, direct commodities or commodity contracts, or private placements (with the exception of Rule 144A securities). Further, derivatives, options, or futures for the sole purpose of direct portfolio leveraging are prohibited. Direct ownership of real estate, natural resource properties such as oil, gas, or timber and the purchase of collectibles is also prohibited.

Control Procedures

Review of Investment Objectives

The Consultant shall review annually and report to the Investment Advisory Board and Governing Body the appropriateness of this Policy Statement for achieving the Fund's stated objectives. It is not expected that this Policy Statement will change frequently. In particular, short-term changes in the financial markets should not require an adjustment in this Policy Statement.

Review of Investment Performance

The Consultant shall report on a quarterly basis to the Investment Advisory Board to review the investment performance of the Fund.

The Consultant shall compare the investment results on a quarterly basis to appropriate peer universe benchmarks, as well as market indices in both equity and fixed income markets. Examples of benchmarks and indexes that will be used include the Russell 3000 Index for broad U.S. equity strategies, S&P 500 Index for large cap U.S. equities, Russell 2000 Index for small cap U.S. equities, MSCI ACWI ex-U.S. Index for broad based non-U.S. equity strategies, MSCI Europe, Australasia, and Far East (EAFE) Index for developed markets international equities, Bloomberg U.S. Aggregate Bond Index for fixed income securities, and the U.S. 91 Day T-bill for cash equivalents. The Russell 3000 Index will be used to benchmark the U.S. equities portfolio; the MSCI ACWI ex-U.S. Index will be used to benchmark the non-U.S. equities portfolio; and the Bloomberg U.S. Aggregate Bond Index will be used to benchmark the fixed income portfolio. The categories "Other" will be benchmarked against appropriate indices depending on the specific characteristics of the strategies and funds used.

Voting of Proxies

The Governing Body recognizes that proxies are a significant and valuable tool in corporate governance. The voting rights of individual stocks held in separate accounts or collective, common, or pooled funds will be exercised by the investment managers in accordance with their own proxy voting policies. The voting rights of funds will be exercised by the NMSIC.

Other Requirements

The Governing Body will establish additional controls and requirements as necessary for any investments outside of the management of the State Investment Council. These requirements will include permissible investments, safekeeping requirements, requirements for delivery versus payment of investment trades, and collateralization.

Adoption of Investment Policy Statement

Any changes and exceptions to this Policy Statement will be made in writing and adopted by the Governing Body via resolution. This Investment Policy Statement was adopted on August 22, 2024, via Resolution 2024-R68.